

# Why SKF?

# Couplings



The global range of shaft couplings is so vast that the SKF range is focused on the ability to supply a coupling type that can satisfy nearly all applications in all types of industry. The available range includes: Flex (Tyre) couplings, FRC couplings, Jaw couplings, Gear couplings, Grid couplings, and Chain couplings.

The heavy duty Gear couplings cover the extreme applications of power and torque, with ability to transmit 555 kN torque and shaft sizes up to 400 mm. The Grid series allows for high speed and power with some ability to absorb shock loads and minimal vibration. These are the heavy series couplings, which require maintenance and lubrication, and attention to installation.

The SKF Flex (Tyre), FRC and Jaw couplings are maintenance-free couplings using rubber elements. They can absorb some vibration, with the SKF Flex couplings offering higher misalignment capabilities than most types. For rubber based couplings, there will be temperature limits (maximum 70 °C).

Other specialist coupling types such as Rigid couplings, Chain Couplings and Disc couplings complete the SKF assortment.

## Product features

- Flexible tyre, jaw, chain, gear, grid, FRC, rigid couplings, and universal joints: no matter which coupling your application requires, SKF offers options for bushings, bored to size or simply piloted
- All couplings are boxed or bagged for protection; over 30 kg (66 lbs) are base mounted for ease of handling and safety

## User benefits

- Enhance worker safety
- Improve hygiene
- Improve product quality
- Improve reliability
- Increase production
- Reduce downtime
- Reduce energy consumption
- Reduce maintenance costs
- Reduce need for maintenance
- Reduce operating costs
- Reduce waste
- Shorten delivery times

## Common applications

- Conveyors
- Fans
- Gearboxes
- Generators
- Horizontal mills
- Motors
- Pulpers
- Pumps
- Screens
- Thickeners

## SKF Flex couplings



- Excellent vibration dampening and shock loading capacity with unrivaled misalignment accommodation
- Easy to install and maintenance free
- Customization: option for bushings, bored to size or simply piloted
- Boxed and bagged for protection; over 30 kg (66 lbs) are base mounted for ease of handling and safety

## FRC couplings

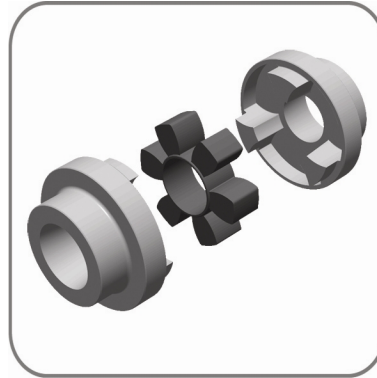

- Designed as a general purpose coupling for moderate shock loads, small vibrations and misalignments
- Customization: option for bushings, bored to size or simply piloted
- Boxed and bagged for protection; over 30kg (66 lbs) are base mounted for ease of handling and safety

## Jaw couplings

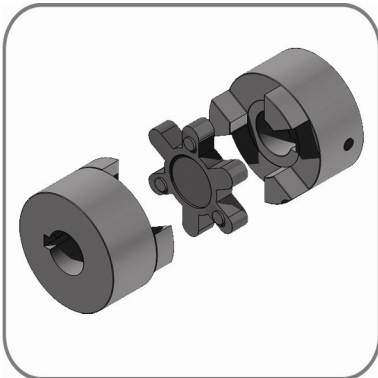

- Cost effective solution for standard applications with moderate shock loads and small vibrations
- Customization: option for bushings, bored to size or simply piloted
- Boxed and bagged for protection; over 30kg (66 lbs) are base mounted for ease of handling and safety

## Universal joints



- Made from high strength steel
- Suitable for a wide variety of applications
- Suitable for high torque, high misalignment and axial movement

© SKF is a registered trademark of the SKF Group.

© SKF Group 2009

The contents of this publication are the copyright of the publisher and may not be reproduced (even extracts) unless permission is granted. Every care has been taken to ensure the accuracy of the information contained in this publication but no liability can be accepted for any loss or damage whether direct, indirect or consequential arising out of the use of the information contained herein.

August 2009

[skf.com](http://skf.com)

