

SKF spherical roller bearings

Setting the standard for performance and reliability





The SKF® brand now stands for more than ever before, and means more to you as a valued customer.

While SKF maintains its leadership as the hallmark of quality bearings throughout the world, new dimensions in technical advances, product support and services have evolved SKF into a truly solutions-oriented supplier, creating greater value for customers.

These solutions encompass ways to bring greater productivity to customers, not only with breakthrough application-specific products, but also through leading-edge design simulation tools and consultancy services, plant asset efficiency maintenance programmes, and the industry's most advanced supply management techniques.

The SKF brand still stands for the very best in rolling bearings, but it now stands for much more.

SKF – the knowledge engineering company

Contents

A Product information

- 3 Economical and robust**
 - 3 Why spherical roller bearings?
 - 4 Why SKF spherical roller bearings?
 - 6 A complete bearing range
- 8 SKF spherical roller bearings – leading in design**
 - 8 Standard bearings: a unique combination of design features
 - 9 Setting new standards: SKF Explorer
 - 10 Sealed SKF spherical roller bearings – for demanding environments
 - 11 SKF spherical roller bearings for vibratory applications
- 12 SKF Explorer™ – the new performance class for spherical roller bearings**
- 14 Efficient in all industrial segments**
 - 14 Where maintenance can be a nightmare
 - 15 Downsizing – more than just size
- 16 Service for lasting partnership**

B Recommendations

- 18 Selection of bearing size**
 - 18 Bearing life
 - 19 Standard and SKF Explorer – a comparison
 - 20 Minimum load
 - 20 Required static load rating
- 21 Application of bearings**
 - 21 Conventional bearing arrangements
 - 22 The SKF self-aligning bearing system
 - 22 Radial location of bearings
 - 23 Axial location of bearings
 - 23 Design of associated components
- 24 Lubrication and maintenance**
 - 24 Oil lubrication
 - 24 Grease lubrication
 - 27 Maintenance

28 Mounting and dismantling

- 28 Bearing storage
- 28 Mounting
- 31 Dismounting

C Product data

- 32 Bearing data – general**
 - 36 Supplementary designations
- 38 Bearing tables**
 - 38 Spherical roller bearings
 - 56 Sealed spherical roller bearings
 - 60 Spherical roller bearings for vibratory applications

D Additional information

- 64 Related SKF products**
 - 64 Special spherical roller bearings
 - 65 Accessories
 - 66 Lubricants and lubrication equipment
 - 66 Products for mounting and dismantling
 - 67 Condition monitoring equipment
- 68 SKF – the knowledge engineering company**

Economical and robust

Why spherical roller bearings?

Spherical roller bearings offer an attractive combination of design features, which are making them irreplaceable in many demanding applications.

- **Self-aligning**

Spherical roller bearings accommodate misalignment between the shaft and housing without increasing friction or reducing bearing service life.

- **Very high load carrying capacity**

Optimized internal geometry within the available cross section provides maximum radial and axial load carrying capacity.

- **Robust**

Insensitive to misalignment caused by shaft or housing deflections as a result of heavy loads.

- **Easily fitted for loads in all directions**

The bearings are non-separable and ready to install, having a choice of mounting methods.

- **Simplify the application**

The favourable design characteristics combined with simplified mounting procedures enable more efficient and compact machine designs.

Spherical roller bearings with integral seals offer additional benefits.

- **Protect against contaminants**

Sealed spherical roller bearings are especially suited for bearing positions where space or cost considerations make external seals impractical.

- **Grease retention**

A contact seal on both sides of the bearing retains the factory grease fill where it is required: inside the bearing.

- **Minimized maintenance requirements**
Under normal operating conditions, sealed spherical roller bearings are maintenance-free, keeping service costs and grease consumption low.



Why SKF spherical roller bearings?

SKF bearings are developed for customer satisfaction. The best confirmation of the total quality of SKF spherical roller bearings is their success on the market. There are twice as many SKF spherical roller bearings in service as those of any other bearing manufacturer.

This is not just by chance: SKF spherical roller bearings are well-proven in the field and undergo continuous development to provide improved performance. Recent examples include the introduction of SKF Explorer™ bearings, which opened up new application horizons, and sealed bearings.

The use of SKF spherical roller bearings implies several benefits.

Application efficiencies

SKF spherical roller bearings have a very high load carrying capacity in the radial and axial directions. Bearing applications become increasingly cost effective due to

- long service life
- compact arrangements.

Reduced operating costs

The optimized and robust internal design of SKF spherical roller bearings minimizes friction and heat, and by this, lubricant consumption. In service, this reduces costs due to

- less machine downtime
- minimized maintenance requirements
- high reliability.

Seals integration

Under normal operating conditions, sealed SKF spherical roller bearings are greased for life and make external seals unnecessary, creating additional benefits

- simplified bearing arrangements
- no relubrication.

Standard solution

Many bearing applications previously fitted with expensive special bearings can now be equipped with SKF spherical roller bearings. Because of the global availability of SKF spherical roller bearings, delivery is not a problem!

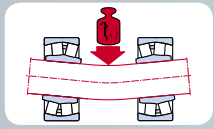

Rugged

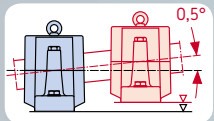

Accommodate misalignment

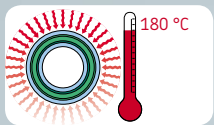

Resistant to high temperatures



Customer satisfaction

Equipment owners will be impressed by the low operating costs in combination with high reliability contributed by SKF spherical roller bearings. Not only are costs reduced, but with sealed versions environmental resources are spared.



*SKF spherical roller bearings:
Always the best choice, when robustness and
reliability matter*



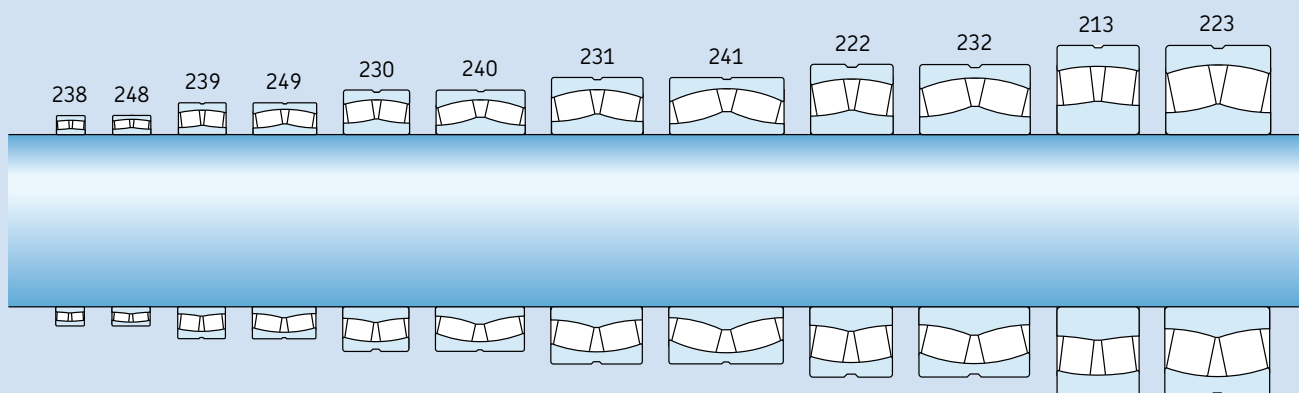

Spherical roller bearing series (open design)

A complete bearing range

The range of open and sealed SKF spherical roller bearings covers all series currently in demand. Taking availability into account, this constitutes the most complete range on the market.

Narrow low-section bearings have better speed, space and weight characteristics. Wide high-section bearings have higher load carrying capacity.

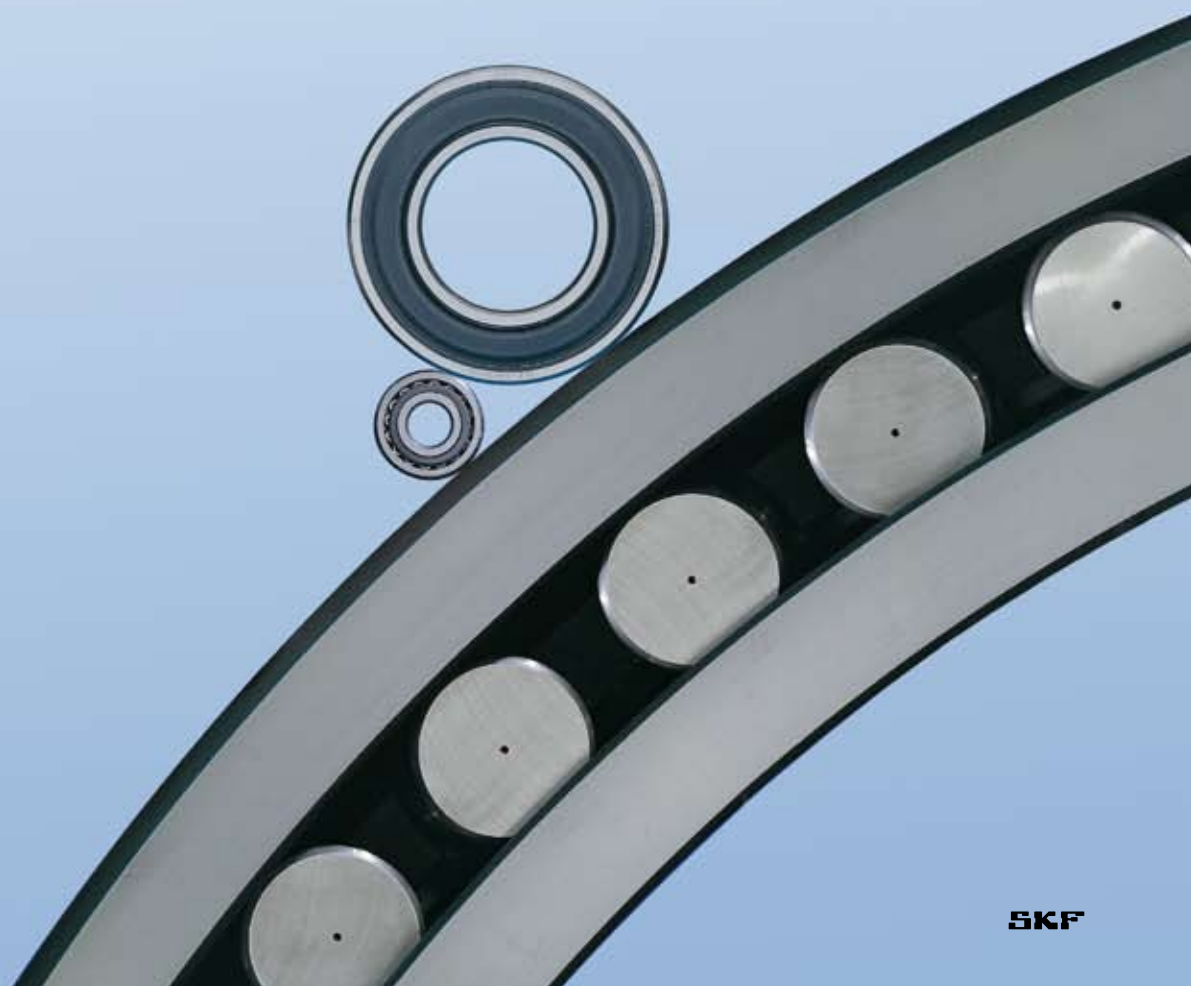

SKF spherical roller bearings without seals

Open bearings are available in sizes from 20 to 1 800 mm bore diameter with either a cylindrical or tapered bore to suit all mounting methods. To facilitate efficient lubrication, most bearings are provided with an annular groove and three lubrication holes in the outer ring.

The bearings are available in a wide number of series designed to satisfy the following selection criteria

- load carrying capacity
- combination of radial and axial loads
- rotational speed
- available space in the application.

Sealed SKF spherical roller bearings

SKF sealed spherical roller bearings are available with a cylindrical bore for shaft diameters ranging from 35 to 220 mm. Bearings with a tapered bore are available for shaft diameters from 40 to 90 mm. Additional sizes can be produced to special order.

The seals, specially developed for spherical roller bearings, effectively prevent contaminants from entering into the rolling contact area. This is not only true in operation, but also during bearing installation, resulting in long service life.



SKF spherical roller bearings – leading in design

Standard bearings: a unique combination of design features

All SKF spherical roller bearings have features in common that are unique in the market

- symmetrical rollers
- special roller profile
- self-guiding rollers – an SKF patent
- floating guide ring between the two rows of rollers
- bearing components dimensionally stabilized for high temperatures
- metallic cages.

To facilitate efficient bearing lubrication SKF standard spherical roller bearings are provided with three lubrication holes in the outer ring, usually in combination with an annular groove. Depending on the series and size, standard SKF spherical roller bearings are basically manufactured to three different designs

- E design
- CC design
- CA design.

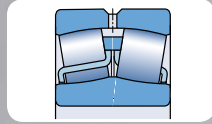

E design
Consists of symmetrical rollers, two hardened window-type steel cages centred on the flangeless inner ring via a floating guide ring between the two rows of rollers.

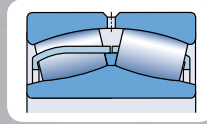

CC design
Consists of symmetrical rollers, two window-type steel cages centred on the flangeless inner ring via a floating guide ring between the two rows of rollers.

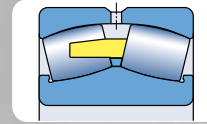

CA design
Consists of symmetrical rollers, a double pronged, machined brass or steel cage, centred on the inner ring via a floating guide ring between the two rows of rollers, an inner ring with retaining flanges.



Durable cage design
Steel and brass cages are strong as well as tolerant to high temperatures and all lubricants. Small and medium size bearings have window-type steel cages, larger sizes have machined brass or steel, double pronged cages.



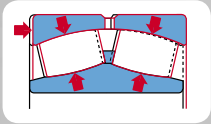

Very high load carrying capacity

The symmetrical rollers self-adjust, providing an even load distribution along the roller length. This provides very high load carrying capacity under all load combinations.

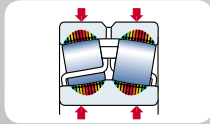

No edge stresses

The special roller profile virtually eliminates the risk of edge stresses.

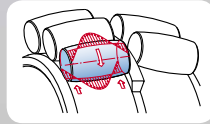

Reduced friction and minimum heat generation

Self-guiding rollers – an SKF patent – mean reduced friction and minimum heat generation.

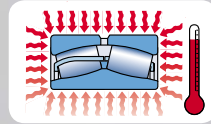

Excellent performance at high temperatures

High-strength, dimensionally stable bearing rings minimize the risk of ring cracking and also enable good performance at high temperatures.

Setting new standards: SKF Explorer

The unique SKF spherical roller bearing designs were the starting points for further development of materials and manufacturing processes. SKF Explorer spherical roller bearings are the result of the work of a very skilled team of engineers and scientists and intensive fine tuning processes, which, taken all together constitutes a new performance level for spherical roller bearings.

- **Steel**
Ultra-clean steel provides longer service life under heavy loads.
- **Heat treatment**
Unique procedures significantly improve wear-resistance and hardness.
- **Manufacturing**
Refined processes enable the production of smoother running bearings that maximize the effects of the lubricant.
- **Internal geometry**
A fine-tuned micro-geometry of the rolling contacts provides better stress distribution.
- **Running accuracy and width tolerances**
The majority of SKF Explorer spherical roller bearings are manufactured as standard to P5 tolerance class for running accuracy. This makes them outstanding on the spherical roller bearing market as well as in relation to other bearing types. A tight width tolerance contributes to simplified mounting procedures in certain applications.

SKF Explorer bearings provide better performance than a similarly sized bearing as explained in more detail from **page 12** onwards.



CA design

Sealed SKF spherical roller bearings – for demanding environments

Sealed SKF spherical roller bearings are designed to fulfil high demands on sealing efficiency and operational reliability under difficult environmental conditions. The seals were developed using computer simulations, making full use of the vast expertise within the SKF Group. They have been tested extensively in the laboratory and in the field and have a proven record of reliable performance and efficiency.

Sealed SKF spherical roller bearings include double-lip, sheet steel reinforced seals and a grease fill that is appropriate to the operating conditions.

Sealed SKF spherical roller bearings are ready to mount and lubricated for life to provide long service life within, in most cases, the same space requirements as a standard open bearing. Advantages include a simplified bearing arrangement as well as the option to make the arrangement more compact. Facilities for relubrication are normally not required, eliminating the need to purchase and dispose of bearing grease.

Temperature limits

Sealed SKF spherical roller bearings are suitable for normal operating temperatures up to +110 °C (230 °F). Bearings for higher operating temperatures can be supplied upon request. In these cases, the grease and seal material must be chosen accordingly. Other operating conditions such as speed may need to be considered as well. Please contact the SKF application engineering service for additional information.

Contamination resistance

Due to the robust and efficient integral seals, additional external seals are not necessary in many applications, generally leading to more compact bearing arrangements. If the operating environment is harsh, external seals should be used (→ fig. 1).

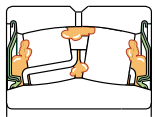

Well lubricated

Bearings for normal operating temperatures and speeds are lubricated with SKF LGEP 2, a grease with a lithium thickener. The grease has excellent rust inhibiting properties.

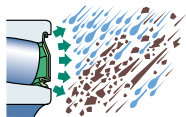

Well protected

The bearings have a sheet steel reinforced double-lip seal on each side. Seals can be made of acrylonitrile-butadiene rubber (NBR), hydrogenated nitrile rubber (HNBR) or fluoro rubber (FKM).

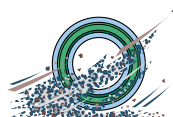

Always reliable

The bearings are filled with a high-quality grease, which is particularly suitable for SKF spherical roller bearings. Integral seals contribute to efficient lubrication by keeping the lubricant inside the bearing.

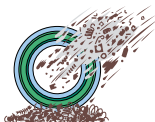

Solid contaminants excluded

Sealed SKF spherical roller bearings provide excellent protection against contaminants. Contaminants can create indentations in raceways and rollers, resulting in flaking and premature failure. Seals also protect the bearing from contaminants during handling and mounting.



Moisture cannot enter

Adequate seals keep moisture out of the bearing, which otherwise would cause corrosion and considerable damage to the raceways, leading to noise and premature failure. The bearings are protected further by the rust inhibiting properties of the lubricant.

A sealed spherical roller bearing in an SNL plummer block housing with external seals

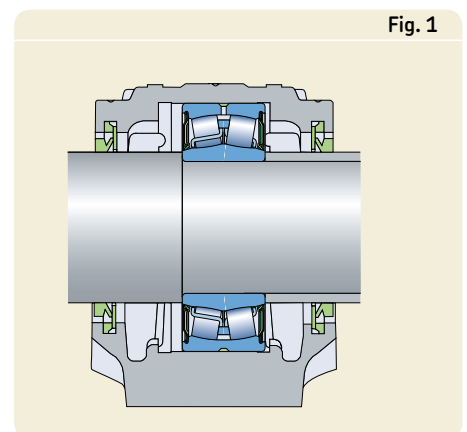

Rule of thumb

Sealed bearings do not need relubrication when

- temperatures do not exceed +70 °C (158 °F)
- the inner ring rotates
- speeds are not more than 50 % of the limiting speeds listed in the product tables.

Additional information can be found in the section "Lubrication and maintenance" starting on page 24.

SKF spherical roller bearings for vibratory applications

For machines with inherent eccentric motion such as vibrating screens and compactors, SKF developed the range of standard spherical roller bearings for vibratory applications. The bearings are available in the 223 series with either a cylindrical or tapered bore for shaft diameters ranging from 40 to 240 mm.

Bearings with the current basic designs have been in service for more than a decade and have been shown to considerably reduce operating temperatures and extend service life of the machinery.

Reinforced for tough operating conditions

The standard bearings for vibratory applications have a special clearance and are modified to cope with the shaft deflections encountered in vibratory applications. They are characterized by a hardened floating guide ring generally centred in the outer ring that guides the highly wear-resistant, surface-hardened window-type steel cages.

The dull-yellowish coloured cages make them distinguishable from bearings for standard applications (→ fig. 2).

To prevent fretting corrosion at the non-locating bearing position, a special version with a PTFE-coated cylindrical bore is available.

Vibratory applications induce accelerations of the rollers and cages in the bearings. These accelerations put additional demands on the bearing and can cause a bearing for standard applications to fail prematurely. SKF spherical roller bearings for vibratory applications are designed to withstand these induced accelerations. The permissible acceleration depends on the lubricant and whether the acceleration is rotating or linear.

Rotating acceleration

This type of acceleration is created in a bearing subjected to a rotating outer ring load and a rotating acceleration field. This generates cyclic loads on the cages from the unloaded rollers. Typical examples are vibrating screens and planetary gears. Road rollers are subject to a mix of rotating and linear accelerations (→ fig. 3a).

Linear acceleration

Linear acceleration occurs when a bearing is subjected to impact loads that hammer the cages. A typical linear acceleration is generated when rail wheels are rolling over rail joints (→ fig. 3b). An analogous application using bearings for vibratory applications is a road roller where the roller is vibrating against a relatively hard surface.

SKF spherical roller bearings for vibratory applications offer decisive benefits:

- Excellent performance in all types of vibrating machinery.
- SKF Explorer performance provides an opportunity to design more compact arrangements.
- Excellent wear-resistant characteristics, even in contaminated environments

Designs

Depending on their size, SKF spherical roller bearings for vibratory applications incorporate one of the following internal designs:

- E/VA405 consists of symmetrical rollers, two hardened window-type steel cages centred on the inner ring and a floating guide ring outside the cages.
- EJA/VA405 consists of symmetrical rollers, two hardened window-type steel cages centred on the outer ring via a floating guide ring between the two roller rows.
- CCJA/W33VA405 consists of symmetrical rollers, two hardened window-type steel cages centred on the outer ring via a floating guide ring between the two roller rows.

Internal designs of SKF spherical roller bearings for vibratory applications

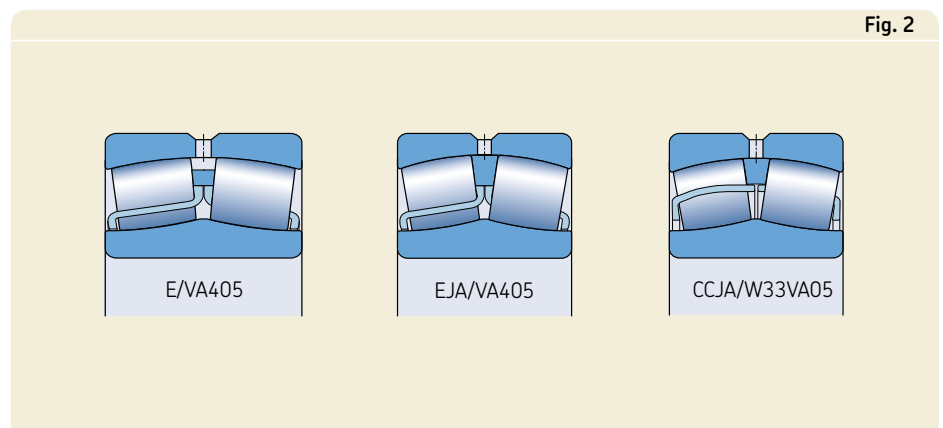
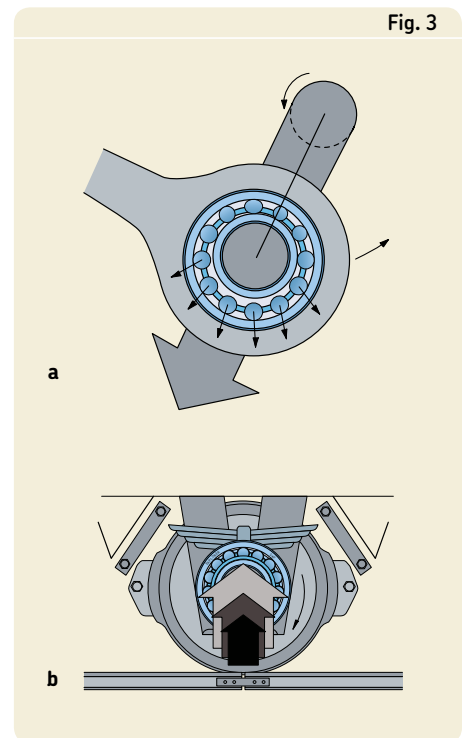

Fig. 2



Example of a bearing subjected to rotating acceleration (a) and linear acceleration (b)

SKF Explorer – the new performance class for spherical roller bearings

Having invented the spherical roller bearing more than 80 years ago, SKF has been the leading manufacturer of these bearings ever since.

Recently, SKF specialists from different disciplines combined their knowledge and experience to take one large step forward in bearing technology. And we are proud of having made tomorrow's bearing technology available for our customers today. SKF Explorer bearings represent a significant breakthrough in performance. By studying the interrelationship between each bearing component, SKF scientists were able to maximize the effects of the lubricant and minimize the effects of friction, wear, and contamination.

Bearings in the SKF Explorer performance class incorporate a number of improvements including:

The material

The steel used in SKF Explorer bearings is extraordinarily clean and homogeneous. It forms an excellent structure which does not generate stress peaks under load.

A unique heat treatment

Together with a refined heat treatment process, the new steel significantly improves the wear-resistance of SKF Explorer bearings. It does this while retaining the temperature resistance and toughness of the bearings.

Improved manufacturing processes

Improved manufacturing processes have enabled SKF to maintain tighter tolerances on all critical bearing parameters. To further improve bearing performance, the finish of all contact surfaces has been maximized to maintain an optimum oil film.

Bearing knowledge

Sophisticated, proprietary software has enabled SKF design engineers to study internal bearing dynamics to an extent not possible previously. This has led the way to refinements, which have been incorporated into SKF Explorer bearings, to further optimize the rolling element/raceway contacts.



The result: longer bearing service life

All these improvements contribute to a significant increase in bearing service life and reliability. This can best be shown through calculation using the SKF rating life equation. The properties of SKF Explorer spherical roller bearings are taken into consideration by

- increased basic dynamic load ratings
- an increased life adjustment factor a_{SKF} .

Availability

The range of high performance SKF Explorer spherical roller bearings is the widest among corresponding bearings on the market.

In the product tables, the designations of SKF Explorer bearings are printed in blue.

Product designations

SKF Explorer bearings retain the designations of earlier standard bearings, e.g. 22218 E or BS2-2210 C-2CS. However, each bearing and its box is marked with the name EXPLORER, so that there can be no confusion.

Existing machine

Switching to SKF Explorer bearings provides

- several times the service life previously achieved
- more machine uptime
- higher safety factor
- an appreciable reduction of machine cycle cost

and, therefore, added value.

New machine with same power

SKF Explorer bearings make it possible to use a smaller bearing size to provide

- more compact machines
- higher speeds
- smoother and quieter running
- less lubricant usage
- reduced friction

and will create added value.

Existing machine with increased power

Same size SKF Explorer bearings enable power increases of 15 to 25 % with

- same service life
- same machine uptime
- same machine design

and higher added value.

New machine with same or increased power

The higher load carrying capacity of SKF Explorer bearings enable the use of a lighter series with the same outside diameter and increased bore diameter, so that

- a stronger, or even hollow shaft can be used
- the total design can be stiffer and also more cost-effective
- system life is increased due to higher stiffness

and machine cycle cost is significantly reduced.

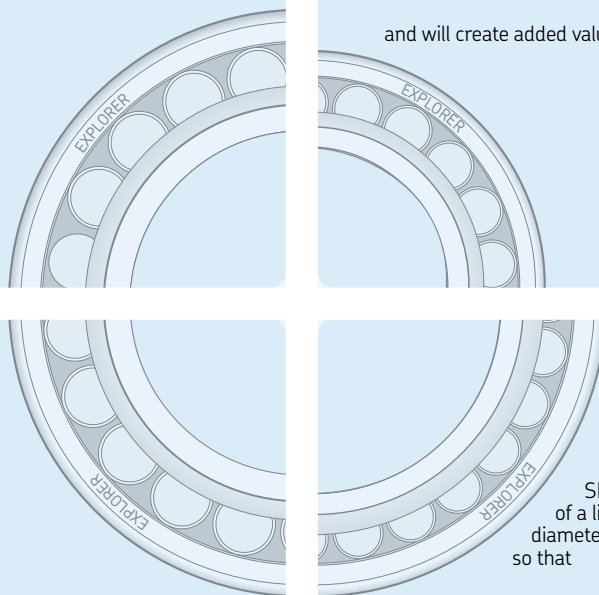

Efficient in all industrial segments

Industrial segments

- Metallurgical
- Mining and construction
- Fluid machinery
- Material handling
- Industrial gearboxes
- Textile industry
- Railways
- Energy

Requirements

- Long service life
- High load carrying capacity
- Compact arrangements
- Accommodate misalignment
- Minimum maintenance
- Reduced operating costs
- Fewer unplanned stops
- Environmental sustainability
- High availability
- Technical support

Solution



Long service life, high reliability, minimized maintenance and the ability to design compact arrangements have made SKF spherical roller bearings indispensable in many industries. In addition to the industrial segments listed above, SKF spherical roller bearings are also used in bridges, dam gates, electric motors, generators, plastic calenders, extruders, printing machines, robots and many other applications.

Because end users are recognizing that high quality bearings deliver an excellent return on investment, SKF spherical roller bearings have become the preferred choice in new applications.

Where maintenance can be a nightmare

To get to the top is always a challenge, particularly if the goal is the top of ski-lift masts in midwinter when it is 30 degrees below zero and the bearings have to be relubricated. If operational reliability is to be achieved, then it has to be done. Regular relubrication is a must if the bearings are to be kept from rusting because of condensation. In addition, safety considerations call for regular inspections – a dangerous job high up in mountainous terrain and under difficult weather conditions.

The introduction of SKF sealed spherical roller bearings has made all the difference. It is now only necessary to perform maintenance once a season – before starting operation. The highly efficient seals reliably exclude condensation so that corrosion is no longer a problem. It has also been possible to simplify the arrangement, saving space and costs – as well as making handling and installation easier.



Downsizing – more than just size

A typical application for spherical roller bearings is the winch of a traversing industrial lift. In this application the loads, deflections and structural deformations call for rugged bearings that can function properly even under misalignment.

Arrangements with open spherical roller bearings provided good service, but were too bulky and complicated to be considered completely satisfactory.

As a result, the open bearings were replaced with SKF sealed spherical roller bearings, eliminating the need for external seals and covers.

This obviously saved space and also meant that the bearings could be positioned 40 % closer to the drum, thus reducing shaft stresses. In fact, it was possible to reduce the shaft diameter by 20 % and use smaller bearings.

The new compact bearing arrangement needs only minimal maintenance and there is no loss of load lifting capacity. The result was a 50 % savings of the total cost of the original bearing arrangement.



A

Service for a lasting partnership



Integrated platform for asset efficiency optimization

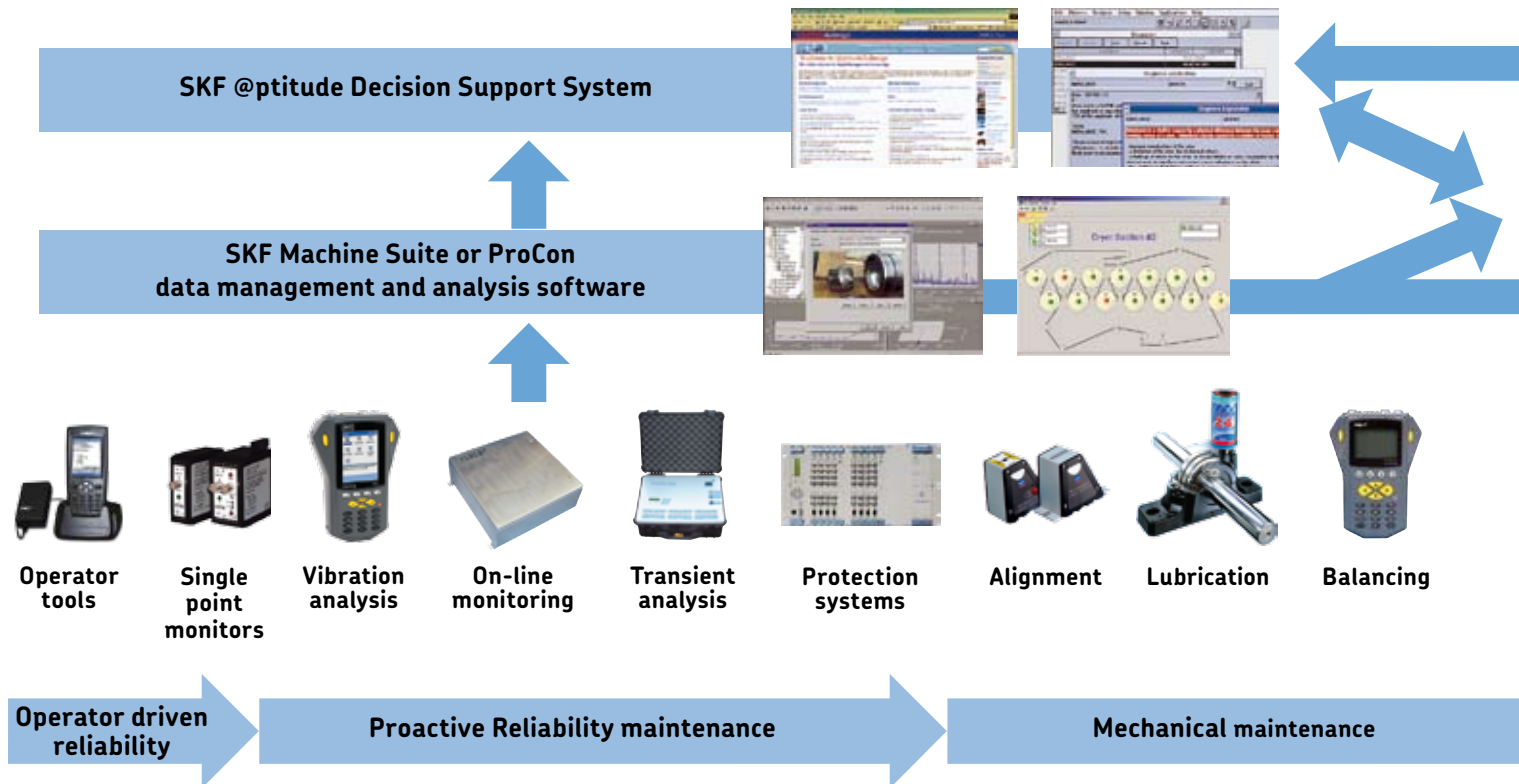

SKF Reliability Systems offers data acquisition hardware, condition monitoring software, decision support systems, and reliability and logistics services.

Based on 100 years of experience with rotating equipment, SKF's expertise begins at the component level and extends to a deep understanding of the technologies required to improve manufacturing processes.

Using this knowledge, SKF can work with you to design more efficiency into your machines and then provide maintenance solutions to keep those machines in peak operating condition.

The result? Improved customer satisfaction – and reduced returns under warranty.



SKF concepts for creating customer value

With experience in virtually every industrial sector, SKF can provide solutions that go beyond simple maintenance to improve machine performance and productivity. With our Total Shaft Solutions™ concept customers can take full advantage of our in-depth competence including, but not limited to

- root cause failure analysis
- maintenance assessments
- predictive and preventive maintenance
- lubrication and filtration management
- equipment maintenance and monitoring – fans, pumps, gearboxes and spindles
- precision balancing
- precision alignment
- applications-specific training
- component and technology upgrades
- installation and repair services.

Another SKF concept that embraces a broader view of improving machine reliability is called Asset Efficiency Optimization (AEO). As the name implies, AEO recognizes the importance of treating machinery and equipment as plant assets. SKF programmes that take a systems approach to managing these assets include

- Proactive reliability maintenance
- Operator driven reliability
- Integrated Maintenance Solutions, which include all-inclusive contractual programmes.

For more information about SKF competencies and services contact your local SKF representative.

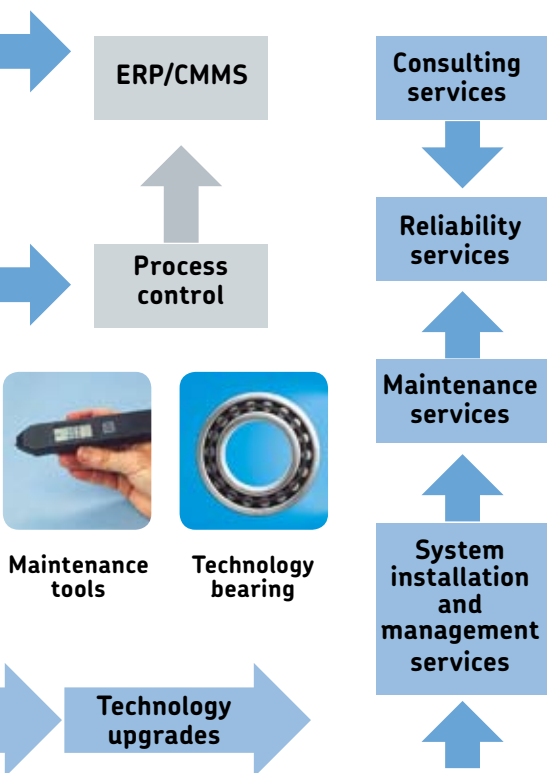

SKF uses its own product, service and knowledge capabilities, in combination with other providers, to implement a complete reliability programme based on specific business goals.

Selection of bearing size

Bearing life

The life-extending improvements embodied in SKF Explorer spherical roller bearings can best be understood using the SKF rating life equation. This calculation method constitutes an extension of the fatigue life theory developed by Lundberg and Palmgren and is better able to predict bearing life. The SKF rating life equation was presented in the SKF General Catalogue 6000 and is in accordance with ISO 281:1990/Amd 2:2000. The equation to be used for roller bearings is

$$L_{nm} = a_1 a_{SKF} L_{10}$$

or

$$L_{nm} = a_1 a_{SKF} \left(\frac{C}{P} \right)^{10/3}$$

If the speed is constant, it is often preferable to calculate the life expressed in operating hours using

$$L_{nmh} = a_1 a_{SKF} \frac{1\,000\,000}{60\,n} \left(\frac{C}{P} \right)^{10/3}$$

where

L_{nm} = SKF rating life (at $100 - n^1$ % reliability), millions of revolutions

L_{nmh} = SKF rating life (at $100 - n^1$ % reliability), operating hours

L_{10} = basic rating life (at 90 % reliability), million revolutions

a_1 = life adjustment factor for reliability (→ **table 1**)

a_{SKF} = SKF life modification factor (→ **diagram 1**)

C = basic dynamic load rating, kN

P = equivalent dynamic bearing load, kN

n = rotational speed, r/min

The a_{SKF} factor

The a_{SKF} factor represents a very complex relationship between various influencing factors: the fatigue load limit ratio, contamination and lubrication. Values of the fatigue load limit (P_U) are provided in the tables. Lubrication conditions are expressed by the viscosity ratio κ . Values of a_{SKF} can be obtained from **diagram 1** for different values of $\eta_c (P_U/P)$ and κ .

For standard spherical roller bearings, the values in black on the x axis should be used and for SKF Explorer bearings the values in blue on the x axis should be used. In fact, for SKF Explorer spherical roller bearings it has been found appropriate to multiply $\eta_c (P_U/P)$ by a factor of 1,4 as an expression of the life extending refinements of these bearings, and the blue values correspond to this.

Diagram 1 has been drawn up for a safety factor commonly used in fatigue life considerations and is valid for lubricants without EP additives. If a lubricant containing such additives is used, reference should be made to the SKF General Catalogue or to the SKF Interactive Engineering Catalogue, available online at www.skf.com.

Equivalent dynamic bearing load

The equivalent dynamic bearing load for spherical roller bearings can be obtained from

$$P = F_r + Y_1 F_a \quad \text{when } F_a/F_r \leq e$$

$$P = 0,67 F_r + Y_2 F_a \quad \text{when } F_a/F_r > e$$

where

P = equivalent dynamic bearing load, kN

F_r = actual radial bearing load, kN

F_a = actual axial bearing load, kN

Y_1, Y_2 = axial load factors for the bearings

e = calculation factor

Appropriate values for the factors e, Y_1 and Y_2 can be found in the bearing tables for each individual bearing.

Table 1

Values for life adjustment factor a_1			
Reliability %	Failure probability n %	SKF rating life L_{nm}	Factor a_1
90	10	L_{10m}	1
95	5	L_{5m}	0,62
96	4	L_{4m}	0,53
97	3	L_{3m}	0,44
98	2	L_{2m}	0,33
99	1	L_{1m}	0,21

¹⁾ The factor n represents the failure probability, i.e. the difference between the requisite reliability and 100 %

Standard and SKF Explorer – a comparison

The performance enhancements incorporated into SKF Explorer spherical roller bearings can best be demonstrated by a life calculation of a bearing 22218 E, comparing the previous standard version with the SKF Explorer bearing.

For the same operating conditions the life of

- the previous standard 22218 E with
 - a basic dynamic load rating $C = 282$ kN, and
 - a fatigue load limit $P_u = 39$ kN, and
- SKF Explorer bearing 22218 E with
 - a basic dynamic load rating $C = 325$ kN, and
 - a fatigue load limit $P_u = 39$ kN

are calculated.

The operating conditions are

- equivalent dynamic bearing load $P = 28,2$ kN
- viscosity ratio $\kappa = 2$
- contamination factor $\eta_c = 0,4$.

The lives of the two bearings are then calculated.

Earlier standard bearing

For $\eta_c (P_u/P) = 0,4 \times 39/28,2 = 0,55$ using the black values on the x axis in **diagram 1** and $\kappa = 2$

$$a_{SKF} = 3,7$$

so that the life becomes

$$L_{10m} = a_{SKF} (C/P)^{10/3} = 3,7 \times (282/28,2)^{10/3}$$

$$L_{10m} = 7\,970 \text{ million revolutions}$$

SKF Explorer bearing

For $\eta_c (P_u/P) = 0,4 \times 39/28,2 = 0,55$ using the blue values on the x axis in **diagram 1** and $\kappa = 2$

$$a_{SKF} = 7,1$$

so that the life becomes

$$L_{10m} = a_{SKF} (C/P)^{10/3} = 7,1 \times (325/28,2)^{10/3}$$

$$L_{10m} = 24\,500 \text{ million revolutions}$$

In this case, the life of the SKF Explorer bearing can be compared with the life of the previous standard bearing by $24\,500/7\,970 = 3,07$ which is just over three times longer life.

Diagram 1

Factor a_{SKF} for spherical roller bearings

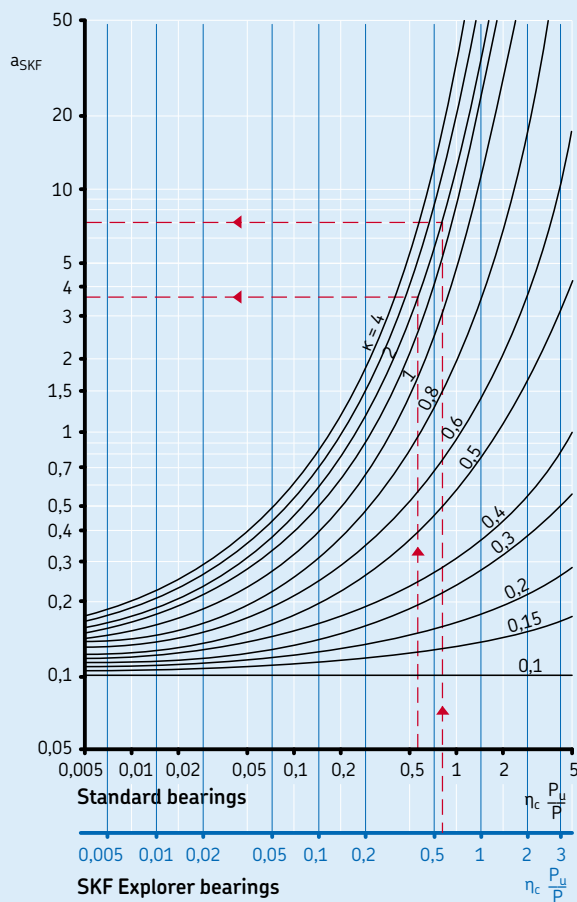

If $\kappa > 4$, use $\kappa = 4$ curve
As the value of $\eta_c (P_u/P)$ tends to zero, a_{SKF} tends to 0,1 for all values of κ

Minimum load

In order to provide satisfactory operation, spherical roller bearings, like all ball and roller bearings, must always be subjected to a given minimum load, particularly if they are to operate at high speeds or are subjected to high accelerations or rapid changes in the direction of load. Under such conditions, the inertia forces of the rollers and cage(s), and the friction in the lubricant, can have a detrimental influence on the rolling conditions in the bearing arrangement and may cause damaging sliding movements to occur between the rollers and raceways.

The requisite minimum load to be applied to spherical roller bearings can be estimated using

$$P_m = 0,01 C_0$$

where

P_m = equivalent minimum load, kN

C_0 = basic static load rating, kN

(→ product tables)

In some applications it is not possible to reach or exceed the requisite minimum load. However, if the bearing is oil lubricated lower minimum loads are permissible. These loads can be calculated

when $n/n_r \leq 0,3$ from

$$P_m = 0,003 C_0$$

and when $0,3 < n/n_r \leq 2$ from

$$P_m = 0,003 C_0 \left(1 + 2 \sqrt{\frac{n}{n_r} - 0,3} \right)$$

where

P_m = equivalent minimum load, kN

C_0 = basic static load rating, kN
(→ product tables)

n = rotational speed, r/min

n_r = reference speed, r/min
(→ product tables)

When starting up at low temperatures or when the lubricant is highly viscous, even greater minimum loads than $P_m = 0,01 C_0$ may be required. The weight of the components supported by the bearing, together with external forces, generally exceeds the requisite minimum load. If this is not the case, the spherical roller bearing must be subjected to an additional radial load.

NoWear® spherical roller bearings have been proven to provide reliable operation under very light loads. They can withstand longer periods

of inadequate lubrication, sudden variations in load and rapid speed changes

Required static load rating

The requisite basic load rating C_0 can be determined from

$$C_0 = s_0 P_0$$

where

C_0 = static load rating, kN

s_0 = static safety factor

P_0 = equivalent static bearing load, kN

Guideline values based on experience are listed in **table 2** for the static safety factor s_0 for various types of operation and requirements regarding smooth running.

The equivalent static bearing load for spherical roller bearings can be obtained from

$$P_0 = F_r + Y_0 F_a$$

where

P_0 = equivalent static bearing load, kN

F_r = actual radial bearing load, kN

F_a = actual axial bearing load, kN

Y_0 = axial load factor of the bearing

The appropriate value for the factor Y_0 can be found in the bearing tables for each individual bearing.

Are you still doing these calculations by hand?

The SKF Interactive Engineering Catalogue (available online at www.skf.com) contains all the equations and underlying software necessary to perform any of the calculations mentioned in this brochure with a click of the mouse.

Guideline values for the static safety factor s_0

Type of operation	Rotating bearings Requirements regarding quiet running			Non-rotating bearings
	Unimportant	Normal	High	
Smooth, vibration-free	1	1,5	3	0,8
Normal	1	1,5	3,5	1
Pronounced shock loads	$\geq 2,5$	≥ 3	≥ 4	≥ 2

Application of bearings

Conventional bearing arrangements

Conventional self-aligning bearing systems using spherical roller bearings in both the locating and non-locating positions, are the basis of many industrial bearing arrangements (→ **fig. 1**). This is a simple robust arrangement capable of withstanding heavy radial and axial loads, while easily accommodating misalignments.

The bearing in the non-locating position must be able to slide axially, usually inside the housing, to accommodate shaft expansion or

contraction. To achieve this movement, one of the bearing rings must be mounted with a loose fit and axial space provided for such movement.

Under certain loading conditions, however, this bearing arrangement may not be suitable. The ring with a loose fit can creep and damage the housing. It can also result in accelerated wear and increased vibration, additional maintenance and repair costs. It also means that the shaft is supported less rigidly in the radial direction. In these situations, the SKF self-aligning bearing system is recommended.

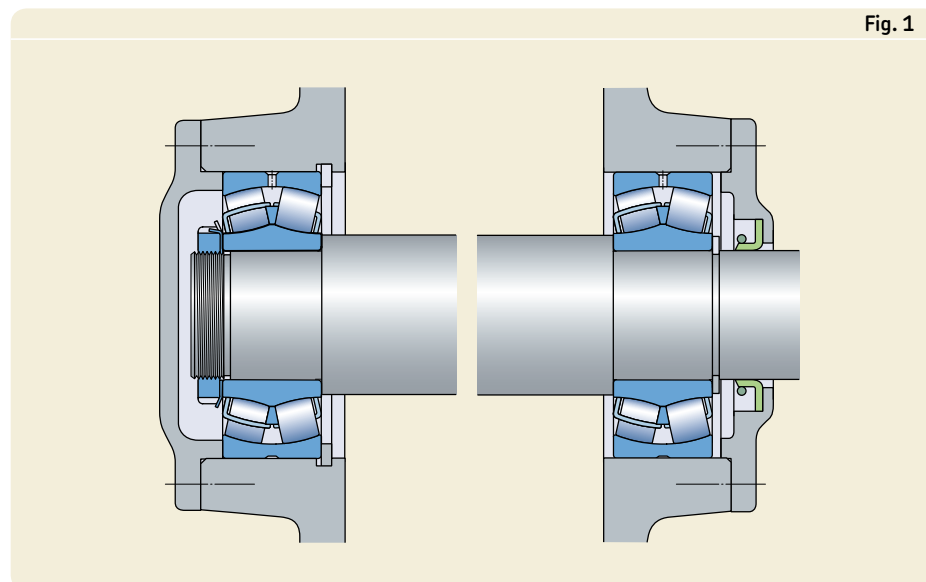

Conventional bearing system with spherical roller bearings in both the locating position (left) and non-locating position (right)

The SKF self-aligning bearing system

The SKF self-aligning bearing system consists of a spherical roller bearing in the locating position and CARB® toroidal roller bearing in the non-locating position (→ fig. 2).

This bearing system accommodates misalignment as well as axial movement of the shaft within the CARB bearing, virtually without friction. As such, the outer rings of both bearings can have a tight fit. Furthermore, there are no induced axial loads which otherwise could be caused by the friction between the sliding outer ring and the housing seating. The bearing system only has to support external loads, which are more predictable.

The benefits of SKF spherical roller bearings and CARB bearings are fully utilized so that engineers can attain the performance characteristics they need for faster, more compact and robust designs.

The SKF self-aligning bearing system enhances reliability and performance. Producers as well as users of machines have clearly reduced costs due to simpler design and increased productivity.

Additional information can be found in the SKF brochure 4417 "Self-aligning bearing systems".

Radial location of bearings

If the load carrying ability of a bearing is to be fully utilized, its rings must be evenly supported around the circumference and across the whole width of the raceway. This support must be firm and even and can be provided by either a cylindrical or tapered seating.

Sufficient support, as well as good radial location of the bearing, generally requires a tight fit between the bearing rings and its adjacent components. However, if easy mounting and dismounting is required, or if a spherical roller bearing is in the non-locating position, a tight fit cannot be applied.

Additional information about fits and the accuracy of bearing seatings can be found in the SKF General Catalogue or online in the SKF Interactive Engineering Catalogue at www.skf.com.

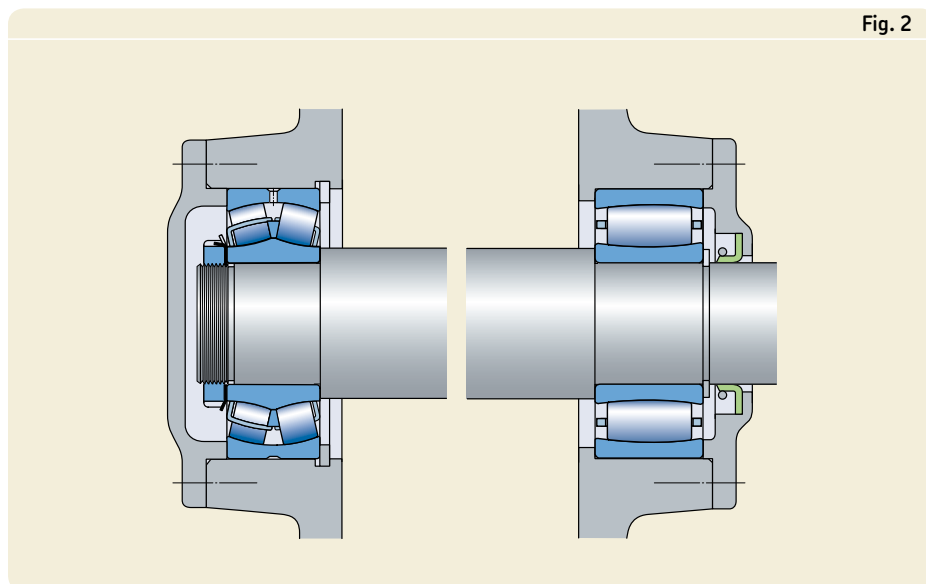

Fig. 2

SKF self-aligning bearing system using a spherical roller bearing in the locating position and a CARB bearing in the non-locating position

Axial location of bearings

An interference fit alone is generally not adequate to locate a spherical roller bearing ring axially. As a rule, some suitable means of axially securing the ring is needed. Both rings of a locating bearing should be axially secured on both sides. For spherical roller bearings in the non-locating position, on the other hand, it is sufficient if the ring having the tighter fit – usually the inner ring – is axially secured; the other ring must be free to move axially relative to its seating (→ **fig. 1** on **page 21**).

Bearing rings having an interference fit are generally mounted so that the ring abuts a shoulder on the shaft or in the housing on one side. On the opposite side, inner rings are normally secured by a snap ring, shaft nut or an end plate attached to the shaft end. Outer rings are usually retained by the housing end cover (→ **fig. 1** on **page 21**).

The dimensions of the shaft and housing shoulders adjacent to the bearing must provide sufficient support for the bearing rings, without making contact with rotating parts of the bearing or a stationary component. To keep this from happening, appropriate abutment dimensions are quoted for each individual bearing listed in the product tables.

If a sealed bearing is secured axially on the shaft by a lock nut, SKF recommends using a KMFE lock nut or an intermediate ring positioned between the bearing and the lock nut (→ **fig. 3**).

Design of associated components

For arrangements with large spherical roller bearings it is often necessary to make design provisions that enable the bearings to be mounted or dismounted easily. For example, withdrawal tools can be used to dismount bearings, if appropriate slots are machined in the shaft and housing shoulders, or if threaded holes are provided in the housing shoulders.

If the oil injection method is to be used to mount and dismount bearings on tapered journals (→ **fig. 4**) or to dismount bearings from cylindrical seatings (→ **fig. 5**), it is necessary to provide an oil supply duct in the journal and a groove in the seating. Recommendations are provided in the SKF General Catalogue and online in the SKF Interactive Engineering Catalogue at www.skf.com.

Sealed bearing axially secured on the shaft by a KMFE lock nut

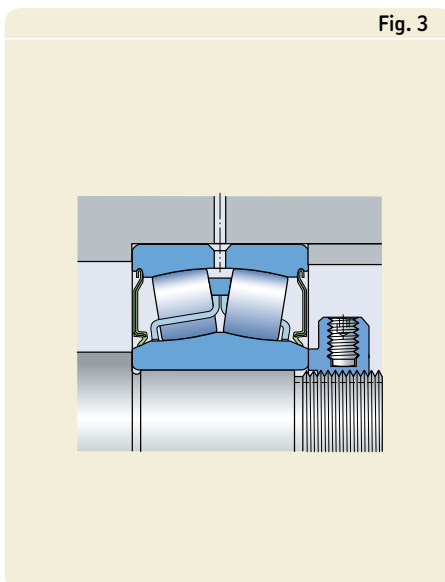

A CAK design spherical roller bearing on a tapered journal with an oil supply duct and groove

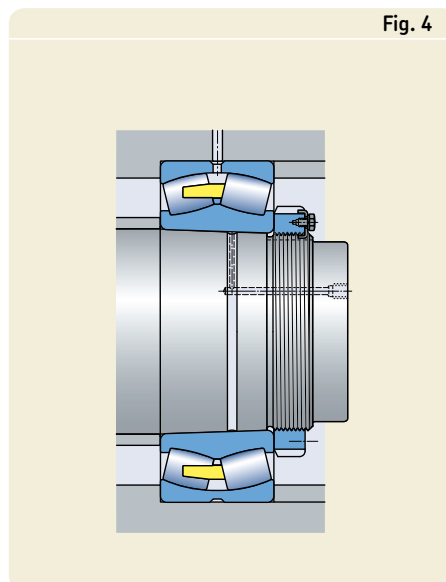

A CA design spherical roller bearing on a cylindrical seating with an oil supply duct and groove

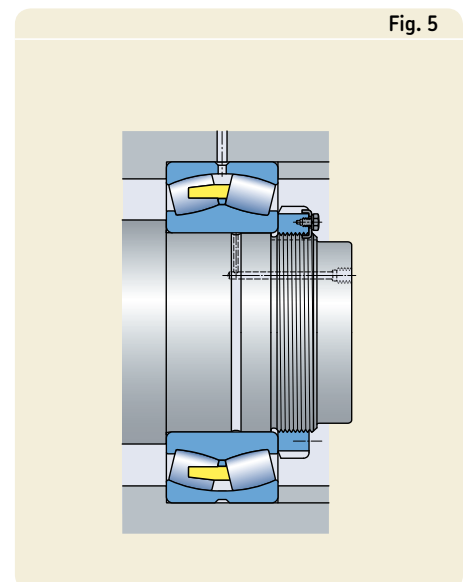

Lubrication and maintenance

Fig. 1

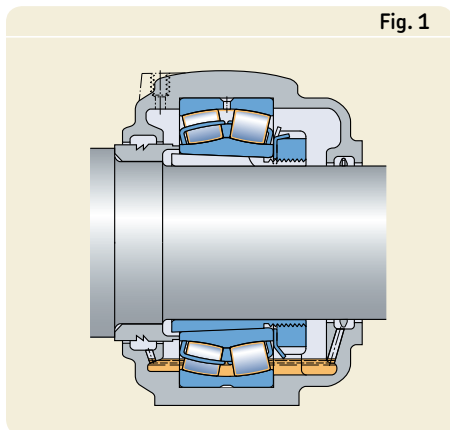

Spherical roller bearing application lubricated by an oil bath

Oil lubrication

When oil is the lubricant, the oil bath or oil recirculating methods are the two most common.

Oil bath

This is the most simple method of oil lubrication (→ fig. 1). The oil, which is picked up by the rotating components of the bearing, is distributed within the bearing and then flows back to the oil sump.

The oil level should be such that it almost reaches the centre of the lowest roller when the bearing is stationary. Even under optimum operating conditions, the oil must be changed at least once a year.

Circulating oil

In a recirculating system, the oil can be continuously filtered and/or cooled (→ fig. 2). This significantly increases the service life of the oil, helping to avoid frequent oil changes.

The circulation can be produced by a pump. In a recirculating system, ducts must be adequately dimensioned so that the oil exits from the housing after passing through the bearing.

An intermediate form of oil circulation is one where the oil is splashed up from the oil bath by other components, e.g. gears in a gearbox.

Fig. 2

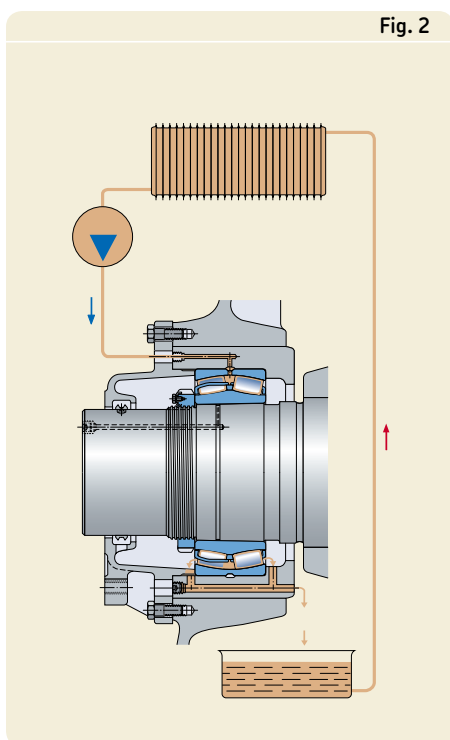

Spherical roller bearing application lubricated by circulating oil

Grease lubrication

Today's modern greases enable an increasing number of maintenance-free bearing applications to be lubricated for life. Here, the selection of sealed SKF spherical roller bearings is the optimum choice, both technically and economically. These bearings are filled with SKF LGEP 2 grease with a lithium thickener, before leaving the factory (→ table 1) and are ready to mount and operate.

In cases where the operating conditions are so harsh that very frequent relubrication is needed or where sealed SKF spherical roller

bearings are not available, SKF offers a full range of greases and tools to enable proper lubrication of the bearing (→ section "Lubricants and lubrication equipment" on page 66).

Relubrication

It is only possible to determine relubrication intervals statistically. SKF bases its relubrication intervals on the time at which 99 % of a seemingly identical lot of bearings are still reliably lubricated, i.e. they correspond to an L_1 grease life which is the relubrication interval t_r . The L_{10} grease life is approximately twice the L_1 life.

If the L_{10} grease life corresponds to, or exceeds, the L_{10} life of the bearing, the bearing is considered to be lubricated for life and relubrication is not required.

The following recommendations are based on the results of long-term tests in various applications. They do not apply where water and/or particulate contaminants can penetrate

Table 1

Technical data for SKF LGEP 2 grease

Property	SKF LGEP 2 grease
Thickener	Lithium
Colour	Light brown
Base oil type	Mineral
NLGI consistency class	2
Temperature range, °C (°F) ¹⁾	-20 to +110 (-4 to +230)
Reference temperature, °C (°F)	60 (140)
Dropping point to ISO 2176, °C (°F)	min. 180 (356)
Base oil viscosity, mm ² /s	
at +40 °C	200
at +100 °C	6

¹⁾ The safe bearing operating temperature according to "The SKF traffic light concept", where the grease will function reliably, lies within +40 to +110 °C

the bearing arrangement. In such cases it is advisable to replenish or renew the grease fill in the arrangement more frequently to remove moisture or other contaminants.

Relubrication

The relubrication intervals t_r for bearings with a rotating inner ring on a horizontal shaft, operating under normal and clean conditions, can be obtained from **diagram 1** as a function of

- the speed factor A multiplied by the relevant bearing factor b_f where
 - $A = n d_m$
 - n = rotational speed, r/min
 - d_m = bearing mean diameter = $0,5 (d + D)$, mm
 - b_f = bearing factor depending on bearing type and load conditions (→ **table 2**)
- the load ratio C/P .

The relubrication interval t_r is an estimated value, valid for an operating temperature of 70 °C, using good quality greases with a lithium thickener and mineral base oil. When bearing operating conditions differ, adjust the relubrication intervals obtained from **diagram 1**.

If the speed factor A exceeds a value of 70 % of the recommended limit (→ **table 2**), or if ambient temperatures are high, one must check the operating temperature and determine whether the appropriate lubricant was applied. This can be done by using the calculations and graphs provided in the SKF General Catalogue, section "Speeds and vibration".

When using high performance greases, longer relubrication intervals and extended grease life may be possible. Contact the SKF application engineering service for additional information.

For additional information about grease lubrication, see the SKF General Catalogue or the SKF Interactive Engineering Catalogue online at www.skf.com.

Diagram 1

Relubrication intervals for grease lubricated spherical roller bearings

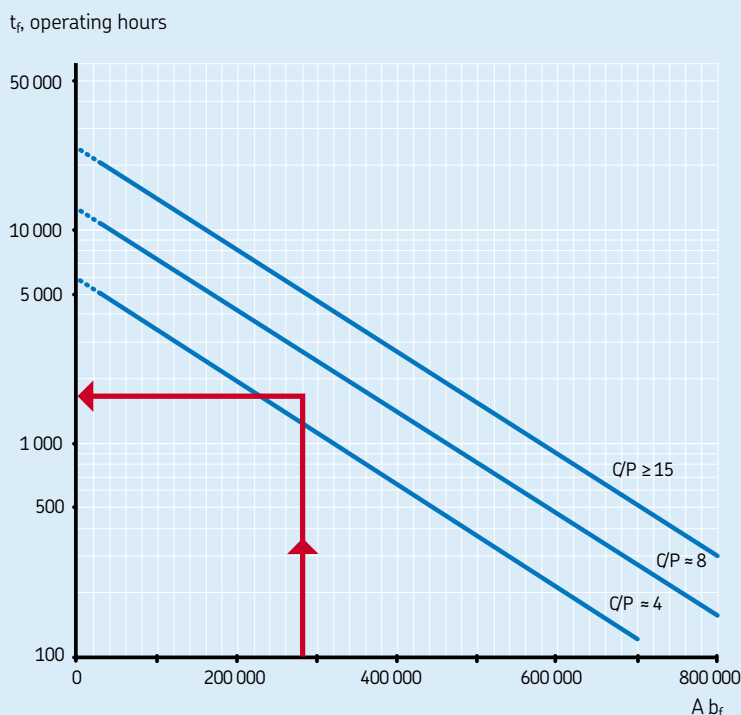

Example

A spherical roller bearing 22220 E rotates at 1 000 r/min. The operating temperature varies between 60 and 70 °C (140 and 158 °F). The equivalent dynamic bearing load $P = 71$ kN and $F_a/F_r < e$. What is the correct lubrication interval? The bearing table on **page 38** lists: $d = 100$ mm, $D = 140$ mm, $C = 425$ kN. Bearing mean diameter $d_m = (100 + 140)/2 = 120$ mm. Bearing factor $b_f = 2$. Speed factor $A = 140\,000$ (i.e. within recommended limit). $A b_f$ is 280 000. $C/P = 425/71 = 6$.

Follow the line in **diagram 1**, from 280 000 on the $A b_f$ axis to the intersection with $C/P = 6$ (extrapolated). Continue horizontally from this intersection to the t_r axis, which shows the final result – a recommended relubrication interval of approximately 2 000 hours.

Table 2

Bearing factors and recommended limits for speed factor A

Bearing type	Bearing factor b_f	Recommended limits for speed factor A for load ratio		
		$C/P \geq 15$	$C/P \approx 8$	$C/P \approx 4$
–	–	mm/min		
Spherical roller bearings				
– when load ratio $F_a/F_r < e$ and $d_m \leq 800$ mm				
series 213, 222, 238, 239	2	350 000	200 000	100 000
series 223, 230, 231, 232, 240, 248, 249	2	250 000	150 000	80 000
series 241	2	150 000	80 000 ¹⁾	50 000 ¹⁾
– when load ratio $F_a/F_r < e$ and $d_m > 800$ mm				
series 238, 239	2	230 000	130 000	65 000
series 230, 231, 232, 240, 248, 249	2	170 000	100 000	50 000
series 241	2	100 000	50 000 ¹⁾	30 000 ¹⁾
– when load ratio $F_a/F_r > e$				
all series	6	150 000	50 000 ¹⁾	30 000 ¹⁾

¹⁾ For higher speeds oil lubrication is recommended

Grease quantity for periodic relubrication

Initially, the bearing should be completely filled, while the free space in the housing should be partly filled. Depending on the intended method of replenishment, the following grease fill percentages for the free space in the housing are recommended:

- 40 % when replenishing from the side of an open bearing.
- 20 % when replenishing through the annular groove and lubrication holes in the bearing outer ring.

Suitable quantities for replenishment from the side of an open bearing can be obtained from

$$G_p = 0,005 D B$$

and for replenishment through the bearing outer or inner ring from

$$G_p = 0,002 D B$$

and for sealed bearings from

$$G_p = 0,0015 D B$$

where

G_p = grease quantity to be added when replenishing, g

D = bearing outside diameter, mm

B = total bearing width, mm

The bearing must rotate during relubrication to achieve proper distribution of the grease.

A polymer band in the annular groove covers the lubrication holes in the outer ring of sealed bearings

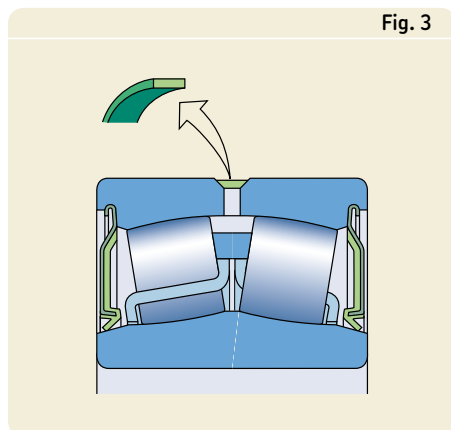

Grease quantity for continuous relubrication

The grease quantity to be continuously supplied can be obtained from

$$G_k = (0,3 \dots 0,5) D B \times 10^{-4}$$

where

G_k = grease quantity to be continuously supplied, g/h

D = bearing outside diameter, mm

B = total bearing width, mm

Continuous relubrication can be efficiently achieved using a SYSTEM 24® lubricator.

Relubrication of sealed SKF spherical roller bearings

The sealed spherical roller bearings shown in the product tables (starting on **page 56**) have an annular groove and three lubrication holes as standard. To prevent the penetration of moisture, and to retain the grease in the bearing, a polymer band in the groove covers the lubrication holes (**→ fig. 3**).

If it is anticipated that bearing relubrication will be necessary during operation, the band should be removed before the bearing is mounted. When relubricating, grease should be applied slowly to the bearing as it rotates until fresh grease emerges from the sealing lips. Excess pressure should be avoided to prevent seal damage.

For additional details, see the SKF General Catalogue or the SKF Interactive Engineering Catalogue online at www.skf.com.

Retaining rings hold the seals in the outer ring

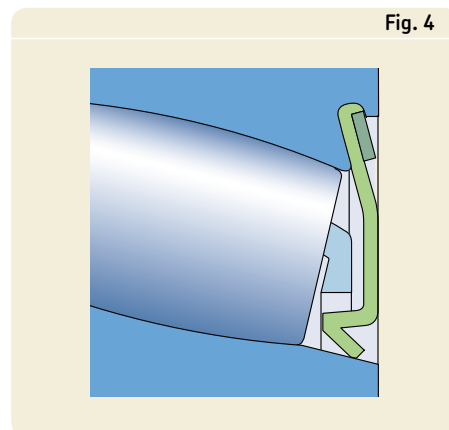

Maintenance

The seals of SKF spherical roller bearings with a bore diameter ≥ 110 mm are secured by retaining rings inserted in the outer ring (\rightarrow fig. 4). The seals can be removed from the bearing so that the bearing can be inspected, washed and regreased, after which the seals can be reinserted and secured. To avoid damage to the seals, this work should be done with care, using blunt tools with no sharp edges.

1. Remove the retaining ring by inserting a tool under the recessed end of the retaining ring (\rightarrow fig. 5) and pushing it out of the groove.
2. Remove the second retaining ring as above.
3. Swivel the inner ring, so that the seals are pushed out by the rollers.
4. Wash the bearing, seals and retaining rings.
5. Inspect all parts for wear and damage.
6. Regrease the bearing with the inner ring swivelled out.
7. Align the bearing parts and put the bearing on a clean surface for remounting the seals.
8. Insert the seal as far as possible into its groove in the outer ring. Hold down the already inserted part of the seal with one hand, press in the remainder stepwise with the thumb of the other hand (\rightarrow fig. 6).

9. Mount the retaining ring by inserting the rectangular end first. Holding this part down, press in the remainder stepwise with a tool, until the whole retaining ring properly contacts the seal as shown in fig. 4
10. Mount the second seal according to steps 7 to 9.
11. If the bearing is not going to be reused immediately, apply oil to all surfaces and make sure that the bearing is packed properly.

Attention

SKF sealed spherical roller bearings can be supplied with different seals. Particular attention is needed for high temperature seals made of fluoro rubber (suffix 2CS2). The fluoro rubber (FKM) of SKF seals is very stable and harmless under normal operating conditions – up to $+200$ °C (392 °F). However, if exposed to extreme temperatures above $+300$ °C (572 °F), e.g. fire or the flame of a cutting torch, fluoro rubber emits dangerous toxic vapours. Once overheated the fluoro rubber will remain dangerous to handle even after it has cooled.

Removing a retaining ring



Inserting the seal in the outer ring



Mounting and dismounting

Bearing storage

Before leaving the factory, SKF spherical roller bearings are treated with a corrosion inhibitor. They can be stored in their unopened original packages for up to five years (three years for sealed bearings), provided the relative humidity in the store does not exceed 60 % (→ **fig. 1**).

To avoid the risk of contamination and corrosion, the original packages should not be opened until immediately before mounting the bearing.

Mounting

Skill and cleanliness are essential when mounting bearings, to make sure that they perform satisfactorily and attain their full potential. Above all, the appropriate mounting method should be chosen and suitable tools used. This is particularly important, where sealed SKF spherical roller bearings are concerned, since misalignment of the inner ring relative to the outer ring in excess of $0,5^\circ$ may damage the seals. For optimum results in mounting and dismounting bearings, SKF offers a full range of tools and equipment. Please refer to the section "Related SKF products" starting on **page 64**.

Bearings with a cylindrical bore

When mounting bearings with a cylindrical bore, the ring with the tighter fit is normally mounted first.

The force required to mount a bearing increases with bearing size. Therefore, it is not always possible to press large bearings onto a cylindrical shaft or into a housing in the cold state. In this case, either the inner ring or the housing should be heated before mounting.

To mount with an interference fit on a shaft the bearing should be heated to some 80 to 90 °C (140 to 160 °F) above the temperature of the shaft. Please remember that sealed bearings should never be heated to more than 110 °C (230 °F).

The use of an SKF induction heater (→ **fig. 2**) has a number of advantages. It heats the bearing rapidly, and a built-in thermostat prevents overheating, which otherwise could damage the bearing. Non-metallic components such as seals remain cold, as does the heater itself.

Mounting bearings by cooling the shaft or the bearing is not recommended, as the very low temperatures required inevitably cause condensation, thus creating a risk of corrosion.

Correct storage of bearings



SKF induction heater



Bearings with a tapered bore

Bearings with a tapered bore are always mounted with an interference fit on the shaft. They can be mounted on adapter or withdrawal sleeves or directly onto tapered journals.

When dimensioning a tapered journal, the distance between the centre of the bearing face in its final mounted position and a reference face on the shaft should be used as a basis (→ **fig. 3**). When the dimension B_a has been established, the dimensioning of the journal should be continued as described in the SKF catalogue 4003 "Large bearings".

Spherical roller bearings up to a 200 mm bore diameter may be driven up onto a tapered journal or a withdrawal sleeve using a shaft nut and onto an adapter sleeve using the sleeve nut and a spanner (→ **fig. 4**).

In applications with larger bearings, heavy drive-up forces are required. Mounting can be facilitated using the oil injection method (→ **fig. 5**). This requires an oil supply duct in the journal and an oil distribution groove in the bearing seating. To further reduce mounting effort, SKF recommends using the oil injection method in combination with an SKF hydraulic nut (→ **fig. 8**).

For a bearing that will be mounted hot, its final axial position on the shaft must be pre-determined. This can be done by means of a tailor-made spacer ring (→ **fig. 6**). When the bearing has cooled, it will obtain its correct interference fit.

The reduction in radial internal clearance of open bearings or the axial displacement of the inner ring on its tapered seating is used as a measure of the degree of interference (→ **fig. 7**).

Tailor-made spacer ring used to position the bearing axially

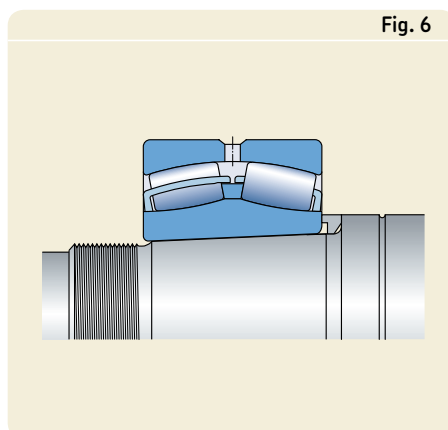

Fig. 6

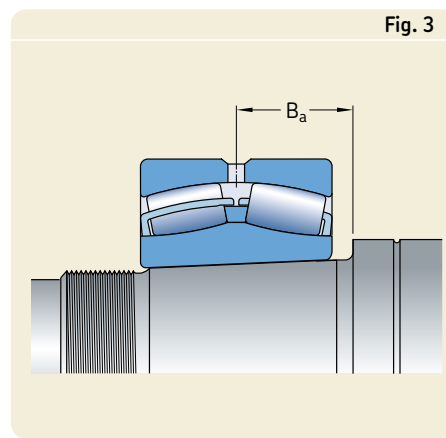

Fig. 3

Dimensioning of a tapered journal

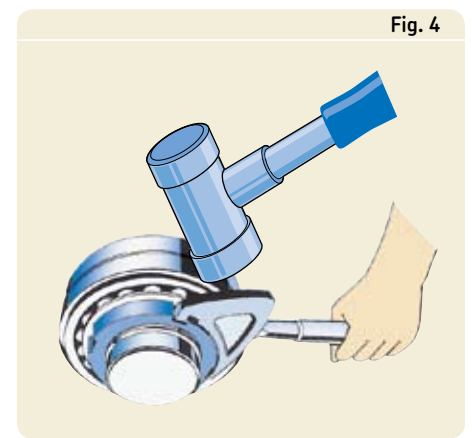

Fig. 4

Mounting of a medium sized bearing

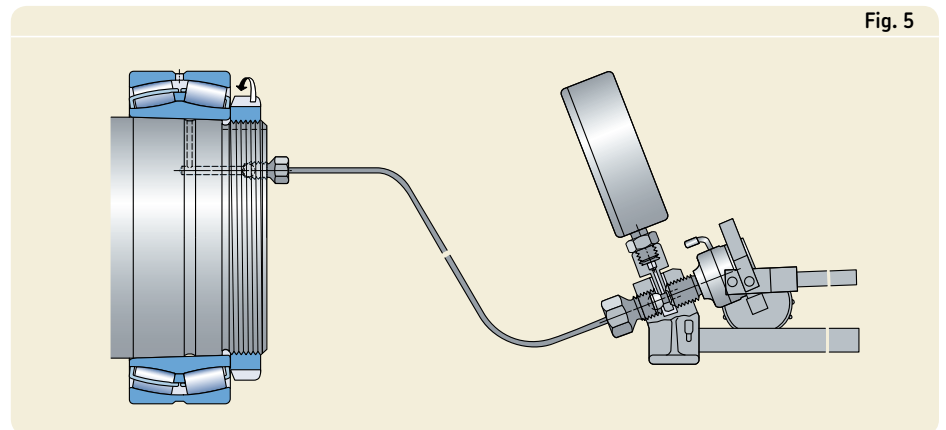

Fig. 5

Drive-up of a large size bearing using the oil injection method

Desired interference obtained by measuring clearance reduction or axial drive-up

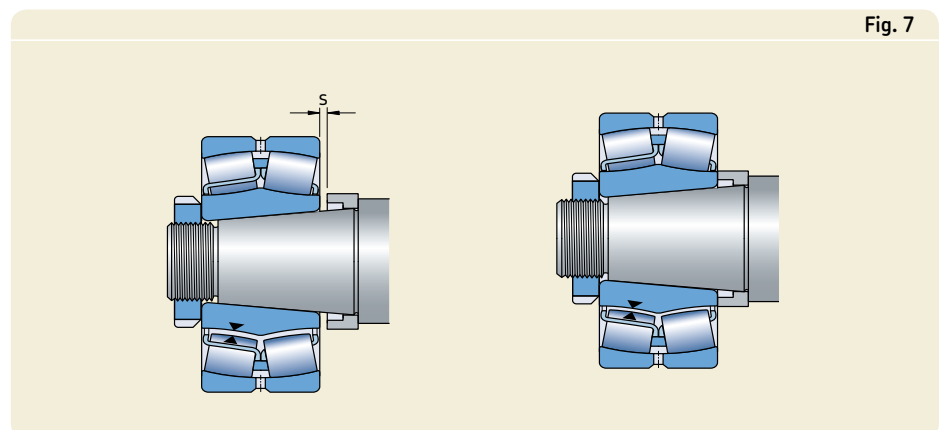

Fig. 7

Using traditional methods, the only way to accurately mount sealed bearings with a tapered bore, is to use the drive-up distance as a measure. However, SKF has devised two additional methods that make installation accurate and fast. The first is the SKF Drive-up Method. This method allows a starting position of the bearing to be easily and accurately determined by applying a well-defined oil pressure to a hydraulic nut. The correct fit is then achieved by controlling the axial drive-up from this position.

The SKF Drive-up Method incorporates the use of a hydraulic nut fitted with a dial indicator to control the drive-up and a specially calibrated pressure gauge, mounted on the selected pump (→ **fig. 8**).

The second method of installation is to use SensorMount®. SensorMount which uses electronics to control the inner ring drive-up, is easy to use, fast, reliable and does not require special mounting skills.

The system comprises a bearing with a sensor and a hand-held indicator. A signal from the sensor is picked up by the indicator which displays a value representing the internal clearance reduction (→ **fig. 9**).

As the indicator displays what is actually happening with the bearing, it does not matter what material the seating is made of or whether the shaft is solid or hollow. No additional calculations or tables are needed to achieve the proper drive-up distance.

SensorMount is available for medium and large size bearings.

Additional information about mounting spherical roller bearings, the SKF Drive-up Method or SensorMount can be found

- in the SKF Interactive Engineering Catalogue online at www.skf.com
- online at www.skf.com/mount.

Mounting a bearing using the SKF Drive-up Method

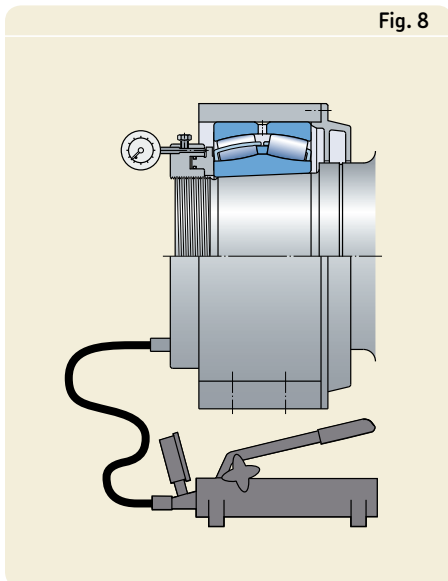

Fig. 8

Mounting a bearing using the SensorMount method

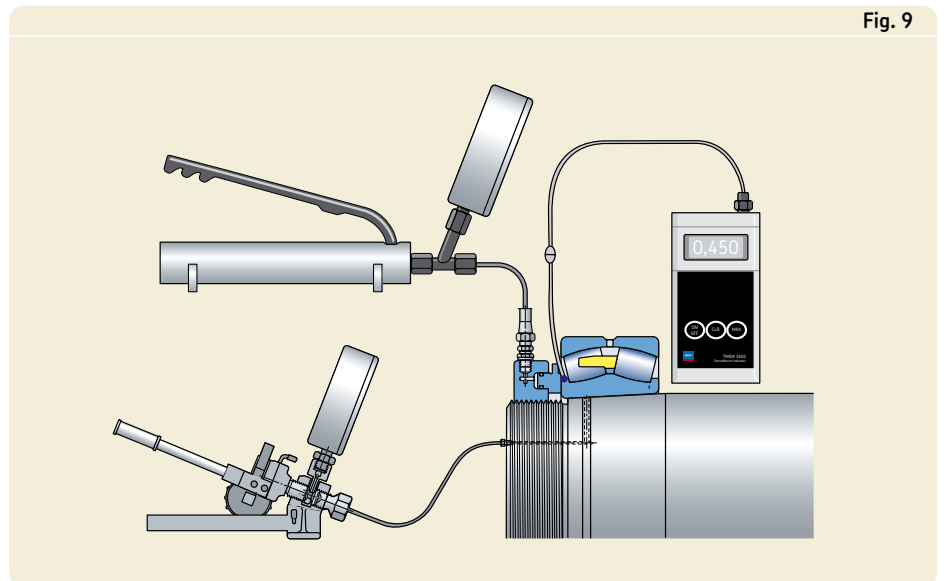
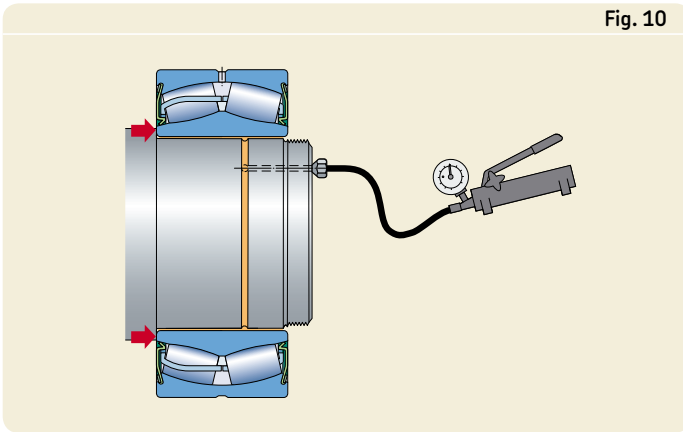

Fig. 9

Fig. 10



Dismounting a bearing from a cylindrical seating using the oil injection method

Fig. 11

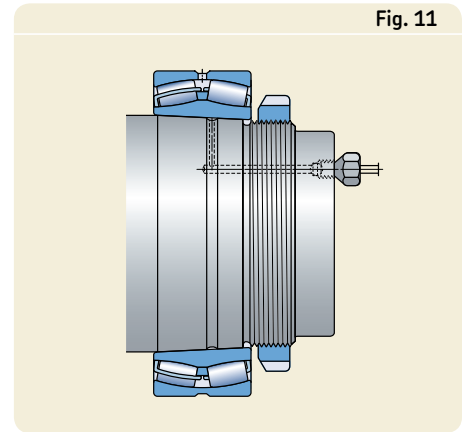

Dismounting a bearing from a tapered journal using the SKF oil injection method

Dismounting

The force required to remove a bearing from its seating is generally greater than the mounting force, particularly if, after a long period of service, fretting corrosion is present. If bearings or other associated components are to be reused after inspection, they must be dismounted as carefully as they were mounted, and the dismounting force should never be applied through the rolling elements.

Bearings with a cylindrical bore

Small bearings can generally be removed using a mechanical puller. The withdrawal tool should grip over the rings from the inside or outside and contact the side faces.

Dismounting bearings on adapter or withdrawal sleeves using hydraulic nuts

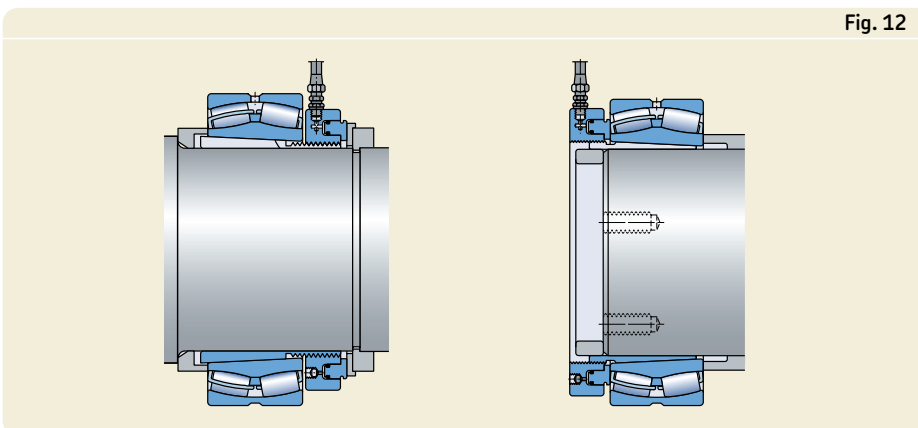

Fig. 12

When bearings with a bore diameter ≥ 80 mm have been mounted on a shaft with an interference fit, dismounting is considerably easier when the SKF oil injection method is used (\rightarrow fig. 10).

Bearings with a tapered bore

To remove spherical roller bearings from tapered journals, the oil injection method is recommended (\rightarrow fig. 11). The film of pressurised oil separates the two mating surfaces and makes the bearing slide off easily.

Bearings mounted on adapter or withdrawal sleeves are most easily removed using a hydraulic nut (\rightarrow fig. 12). By using sleeves with oil ducts and oil distribution grooves, the oil injection method facilitates the removal of large bearings (\rightarrow fig. 13).

Safety note
When using the oil injection method to dismount a bearing from a tapered seating, be sure to block the end of the shaft with a lock nut or other suitable device to prevent the bearing from falling.

Additional information about dismounting spherical roller bearings can be found

- in the SKF Interactive Engineering Catalogue online at www.skf.com
- online at www.skf.com/mount.

Dismounting a large size bearing on a withdrawal sleeve with oil ducts and grooves

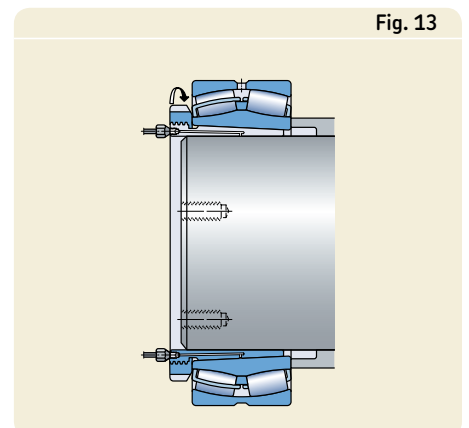

Fig. 13

Bearing data – general

Designs

Depending on the size and series, SKF spherical roller bearings incorporate one of the internal designs shown below. Common features of all designs include symmetrical rollers and a floating guide ring between the roller rows. The arrangement of the guide ring as well as the cage execution are different for the various designs.

E design ($d \leq 65$ mm)

Guide ring centred on the inner ring, two window-type steel cages.

E design ($d > 65$ mm)

Guide ring centred on the cages, two window-type steel cages.

EJA design

Guide ring centred on the outer ring, two window-type steel cages.

C, CC, EC and ECC designs

Guide ring centred on the inner ring, two window-type steel cages.

CCJA design

Guide ring centred on the outer ring, two window-type steel cages.

CA, CAF, ECA and ECAF designs

Guide ring centred on the inner ring, retaining flanges on the inner ring, one-piece machined cage of brass or steel (suffix F).

CAFA and CAMA designs

Guide ring centred on the inner ring, retaining flanges on the inner ring, one-piece machined cage of steel (CAFA) or brass (CAMA).

SKF Explorer

The designations of SKF Explorer bearings are printed in blue in the product tables.

Cylindrical or tapered bore

SKF spherical roller bearings are available with either a cylindrical or tapered bore. The tapered bore of bearings in the 240, 241, 248 and 249 series is 1:30. The tapered bore of bearings in the other series is 1:12.

Annular groove and lubrication holes

Efficient lubrication of SKF spherical roller bearings is facilitated by either

- three lubrication holes and an annular groove (E design or suffix W33) or
- three lubrication holes without annular groove (suffix W20).

Dimensions

The boundary dimensions of SKF spherical roller bearings with or without seals are in accordance with ISO 15:1998, except for the width of sealed bearings in the BS2-22 series. These are basically bearings in the 222 E or 222 CC series, but are slightly wider to integrate the seals.

Tolerances

SKF spherical roller bearings are manufactured as standard to Normal tolerances.

SKF Explorer spherical roller bearings up to and including 300 mm bore diameter are,

however, produced to higher precision than the ISO Normal tolerances. For example

- the width tolerance is considerably tighter than the ISO Normal tolerance (→ SKF General Catalogue 6000)
- the running accuracy is to P5 tolerance class as standard.

For applications with larger bearings where running accuracy is a key operational parameter, SKF spherical roller bearings with P5 running accuracy are also available. These bearings are identified by the suffix C08. Contact SKF for availability.

The tolerance for the bore and the outside diameter of SKF Explorer spherical roller bearings for vibratory applications has been tightened from Normal to P5 and P6 respectively.

The values of the tolerances are in accordance with ISO 492:2002.

Internal clearance

SKF spherical roller bearings are manufactured as standard with Normal radial internal clearance. Nearly all the bearings are also available with a larger C3 internal clearance and some can be supplied with an even larger C4 or C5 clearance. Some sizes can be delivered with C2 internal clearance which is smaller than Normal. Contact SKF for availability of bearings with radial internal clearance other than Normal before ordering. The various radial internal clearances are in accordance with ISO 5753:1991 and shown in **tables 1** and **2**. They are valid for zero measuring load before mounting.

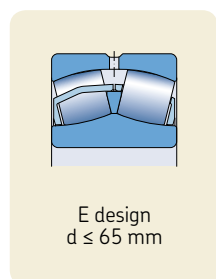

E design
 $d \leq 65$ mm

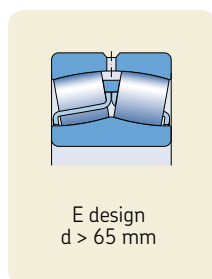

E design
 $d > 65$ mm

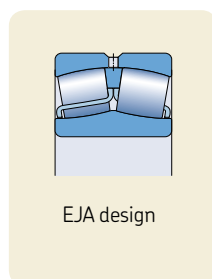

EJA design

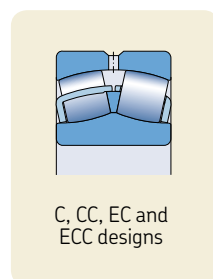

C, CC, EC and
ECC designs

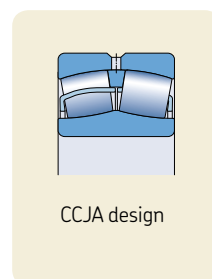

CCJA design

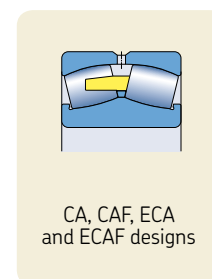

CA, CAF, ECA
and ECAF designs

Table 1

Radial internal clearance of spherical roller bearings with a cylindrical bore

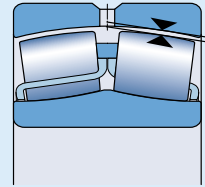

Bore diameter d		Radial internal clearance									
over	incl.	C2		Normal		C3		C4		C5	
		min	max	min	max	min	max	min	max	min	max
mm		µm									
18	24	10	20	20	35	35	45	45	60	60	75
24	30	15	25	25	40	40	55	55	75	75	95
30	40	15	30	30	45	45	60	60	80	80	100
40	50	20	35	35	55	55	75	75	100	100	125
50	65	20	40	40	65	65	90	90	120	120	150
65	80	30	50	50	80	80	110	110	145	145	185
80	100	35	60	60	100	100	135	135	180	180	225
100	120	40	75	75	120	120	160	160	210	210	260
120	140	50	95	95	145	145	190	190	240	240	300
140	160	60	110	110	170	170	220	220	280	280	350
160	180	65	120	120	180	180	240	240	310	310	390
180	200	70	130	130	200	200	260	260	340	340	430
200	225	80	140	140	220	220	290	290	380	380	470
225	250	90	150	150	240	240	320	320	420	420	520
250	280	100	170	170	260	260	350	350	460	460	570
280	315	110	190	190	280	280	370	370	500	500	630
315	355	120	200	200	310	310	410	410	550	550	690
355	400	130	220	220	340	340	450	450	600	600	750
400	450	140	240	240	370	370	500	500	660	660	820
450	500	140	260	260	410	410	550	550	720	720	900
500	560	150	280	280	440	440	600	600	780	780	1 000
560	630	170	310	310	480	480	650	650	850	850	1 100
630	710	190	350	350	530	530	700	700	920	920	1 190
710	800	210	390	390	580	580	770	770	1 010	1 010	1 300
800	900	230	430	430	650	650	860	860	1 120	1 120	1 440
900	1 000	260	480	480	710	710	930	930	1 220	1 220	1 570
1 000	1 120	290	530	530	780	780	1 020	1 020	1 330	1 330	1 720
1 120	1 250	320	580	580	860	860	1 120	1 120	1 460	1 460	1 870
1 250	1 400	350	640	640	950	950	1 240	1 240	1 620	1 620	2 060
1 400	1 600	400	720	720	1 060	1 060	1 380	1 380	1 800	1 800	2 300
1 600	1 800	450	810	810	1 180	1 180	1 550	1 550	2 000	2 000	2 550

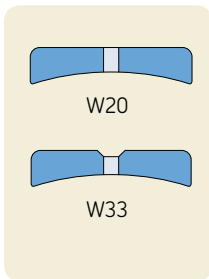
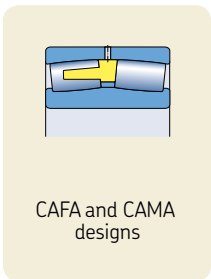
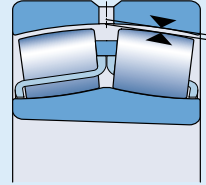

Table 2

Radial internal clearance of spherical roller bearings with a tapered bore



Bore diameter		Radial internal clearance									
d over	incl.	C2		Normal		C3		C4		C5	
		min	max	min	max	min	max	min	max	min	max
mm		µm									
24	30	20	30	30	40	40	55	55	75	–	–
30	40	25	35	35	50	50	65	65	85	85	105
40	50	30	45	45	60	60	80	80	100	100	130
50	65	40	55	55	75	75	95	95	120	120	160
65	80	50	70	70	95	95	120	120	150	150	200
80	100	55	80	80	110	110	140	140	180	180	230
100	120	65	100	100	135	135	170	170	220	220	280
120	140	80	120	120	160	160	200	200	260	260	330
140	160	90	130	130	180	180	230	230	300	300	380
160	180	100	140	140	200	200	260	260	340	340	430
180	200	110	160	160	220	220	290	290	370	370	470
200	225	120	180	180	250	250	320	320	410	410	520
225	250	140	200	200	270	270	350	350	450	450	570
250	280	150	220	220	300	300	390	390	490	490	620
280	315	170	240	240	330	330	430	430	540	540	680
315	355	190	270	270	360	360	470	470	590	590	740
355	400	210	300	300	400	400	520	520	650	650	820
400	450	230	330	330	440	440	570	570	720	720	910
450	500	260	370	370	490	490	630	630	790	790	1 000
500	560	290	410	410	540	540	680	680	870	870	1 100
560	630	320	460	460	600	600	760	760	980	980	1 230
630	710	350	510	510	670	670	850	850	1 090	1 090	1 360
710	800	390	570	570	750	750	960	960	1 220	1 220	1 500
800	900	440	640	640	840	840	1 070	1 070	1 370	1 370	1 690
900	1 000	490	710	710	930	930	1 190	1 190	1 520	1 520	1 860
1 000	1 120	530	770	770	1 030	1 030	1 300	1 300	1 670	1 670	2 050
1 120	1 250	570	830	830	1 120	1 120	1 420	1 420	1 830	1 830	2 250
1 250	1 400	620	910	910	1 230	1 230	1 560	1 560	2 000	2 000	2 450
1 400	1 600	680	1 000	1 000	1 350	1 350	1 720	1 720	2 200	2 200	2 700
1 600	1 800	750	1 110	1 110	1 500	1 500	1 920	1 920	2 400	2 400	2 950

Misalignment

The design of spherical roller bearings is such that they are inherently self-aligning, i.e. angular misalignment between the outer ring and inner ring can be accommodated without any negative effect on bearing performance. Under normal operating conditions, i.e. load ratios of $C/P > 10$ and misalignment is constant in position instead of relative to the outer ring, the guideline values for permissible misalignment of open bearings provided in **table 3** apply. Whether or not these values can be fully exploited depends on the design of the bearing arrangement, the type of external seals used etc.

When the position of misalignment is not constant with respect to the bearing outer ring, e.g. in

- vibrating screens with rotating imbalance and therefore rotating deflection of the shaft (→ **fig. 1**)
- deflection-compensating rolls of paper machines where the stationary shaft is bent

additional sliding can occur in the bearing. Therefore, taking bearing friction and associated heat generation into consideration, misalignment of the inner ring relative to the outer ring should not exceed a few tenths of a degree.

Sealed bearings can accommodate angular misalignment of the shaft relative to the housing of up to $0,5^\circ$ with no detrimental effect on the efficiency of the seals.

Influence of operating temperature on the bearing materials

SKF spherical roller bearing rings and rollers undergo a unique heat treatment process so that they can withstand temperatures up to $+200^\circ\text{C}$ (390°F) for up to 2 500 hours, or brief periods at even higher temperatures, without any inadmissible dimensional changes occurring. If provision is made to accommodate slight changes of fits and clearance, even higher temperatures or longer periods can be accommodated.

Sealed SKF spherical roller bearings with standard seals and grease should not be used at operating temperatures above $+110^\circ\text{C}$ (230°F) as this would be detrimental to the seals and grease.

Axial load carrying capacity

Because of their special internal design, SKF spherical roller bearings not only have lower friction than other spherical roller bearings, but they are also able to accommodate appreciably heavier axial loads. However, if $F_a/F_r > e$ (→ **product tables**), more frequent lubrication is recommended.

Speed ratings

Due to the friction generated by contact seals, the speed rating for a sealed bearing operating within the normal temperature range is approximately 40 % less than for a corresponding open bearing.

Table 3

Permissible angular misalignment for open bearings

Bearing series Sizes ¹⁾	Permissible angular misalignment
–	degrees
Series 213	2
Series 222 Sizes < 52 Sizes ≥ 52	2 1,5
Series 231 Sizes < 60 Sizes ≥ 60	2 3
Series 232 Sizes < 52 Sizes ≥ 52	2,5 3,5
Series 238	1,5
Series 239	1,5
Series 240	2
Series 241 Sizes < 64 Sizes ≥ 64	2,5 3,5
Series 248	1,5
Series 249	2,5

¹⁾ Last two figures of bearing designations

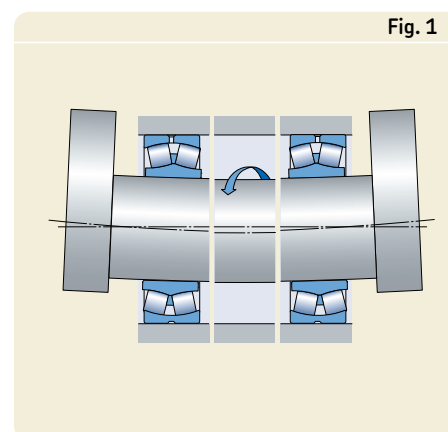

Fig. 1

Supplementary designations

The designation suffixes used to identify certain features of SKF spherical roller bearings are explained below.

C2	Radial internal clearance smaller than Normal	VE553(E)	Outer ring with three equally spaced threaded holes in both side faces to accommodate hoisting tackle; the E indicates that appropriate eye bolts are supplied with the bearings
C3	Radial internal clearance greater than Normal	VG114	Surface hardened pressed steel cages
C4	Radial internal clearance greater than C3	VQ424	Running accuracy better than C08
C5	Radial internal clearance greater than C4	VT143	Grease fill 25 to 35 % with SKF LGEP 2 grease
C08	Increased running accuracy to ISO tolerance class 5	W	No relubrication facility in the outer ring
C083	C08 + C3	W20	Three lubrication holes in the outer ring
C084	C08 + C4	W26	Six lubrication holes in the inner ring
2CS	Sheet steel reinforced contact seal of acrylonitrile-butadiene rubber (NBR) on both sides of the bearing. Grease fill 25 to 35 % with SKF LGEP 2 grease. Annular groove and three lubrication holes in the outer ring.	W33	Annular groove and three lubrication holes in the outer ring
2CS2	Sheet steel reinforced contact seal of fluoro rubber (FPM) on both sides of the bearing. Grease fill 70 to 100 % with a polyurea high temperature grease. Annular groove and three lubrication holes in the outer ring	W64	Solid Oil filling
2CS5	Sheet steel reinforced contact seal of hydrogenated acrylonitrile-butadiene rubber (HNBR) on both sides of the bearing. Grease fill 70 to 100 % with a polyurea high temperature grease. Annular groove and three lubrication holes in the outer ring	W77	Plugged W33 lubrication holes
HA3	Case hardened inner ring	W513	W26 + W33
K	Tapered bore, taper 1:12	235220	Case hardened inner ring with a helical groove in the bore
K30	Tapered bore, taper 1:30		
P5	Dimensional and running accuracy to ISO tolerance class 5		
P6	Dimensional and running accuracy to ISO tolerance class 6		
P62	P6 + C2		
VA405	Bearing for vibratory applications		
VA406	Bearing for vibratory applications with PTFE-coated bore		
VE552(E)	Outer ring with three equally spaced threaded holes in one side face to accommodate hoisting tackle; the E indicates that appropriate eye bolts are supplied with the bearings		

Spherical roller bearings
d 20 – 80 mm

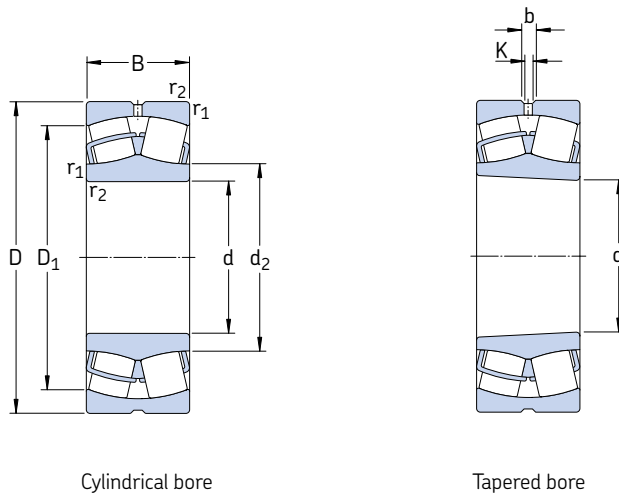

Cylindrical bore

Tapered bore

Principal dimensions			Basic load ratings		Fatigue load limit P_u	Speed ratings		Mass	Designations	
d	D	B	dynamic C	static C_0		Refer- ence speed	Limiting speed		Bearing with cylindrical bore	tapered bore
mm			kN		kN	r/min		kg	–	
20	52	18	49	44	4,75	13 000	17 000	0,28	22205/20 E	–
25	52	18	49	44	4,75	13 000	17 000	0,26	22205 E	22205 EK
	62	17	41,4	41,5	4,55	8 500	12 000	0,28	21305 CC	–
30	62	20	64	60	6,4	10 000	14 000	0,29	22206 E	22206 EK
	72	19	55,2	61	6,8	7 500	10 000	0,41	21306 CC	21306 CCK
35	72	23	86,5	85	9,3	9 000	12 000	0,45	22207 E	22207 EK
	80	21	65,6	72	8,15	6 700	9 500	0,55	21307 CC	21307 CCK
40	80	23	96,5	90	9,8	8 000	11 000	0,53	22208 E	22208 EK
	90	23	104	108	11,8	7 000	9 500	0,75	21308 E	21308 EK
	90	33	150	140	15	6 000	8 000	1,05	22308 E	22308 EK
45	85	23	102	98	10,8	7 500	10 000	0,58	22209 E	22209 EK
	100	25	125	127	13,7	6 300	8 500	0,99	21309 E	21309 EK
	100	36	183	183	19,6	5 300	7 000	1,40	22309 E	22309 EK
50	90	23	104	108	11,8	7 000	9 500	0,63	22210 E	22210 EK
	110	27	156	166	18,6	5 600	7 500	1,35	21310 E	21310 EK
	110	40	220	224	24	4 800	6 300	1,90	22310 E	22310 EK
55	100	25	125	127	13,7	6 300	8 500	0,84	22211 E	22211 EK
	120	29	156	166	18,6	5 600	7 500	1,70	21311 E	21311 EK
	120	43	270	280	30	4 300	5 600	2,45	22311 E	22311 EK
60	110	28	156	166	18,6	5 600	7 500	1,15	22212 E	22212 EK
	130	31	212	240	26,5	4 800	6 300	2,10	21312 E	21312 EK
	130	46	310	335	36,5	4 000	5 300	3,10	22312 E	22312 EK
65	100	35	132	173	20,4	4 300	6 300	0,95	24013 CC/W33	24013 CCK30/W33
	120	31	193	216	24	5 000	7 000	1,55	22213 E	22213 EK
	140	33	236	270	29	4 300	6 000	2,55	21313 E	21313 EK
	140	48	340	360	38	3 800	5 000	3,75	22313 E	22313 EK
70	125	31	208	228	25,5	5 000	6 700	1,55	22214 E	22214 EK
	150	35	285	325	34,5	4 000	5 600	3,10	21314 E	21314 EK
	150	51	400	430	45	3 400	4 500	4,55	22314 E	22314 EK
75	115	40	173	232	28,5	3 800	5 300	1,55	24015 CC/W33	24015 CCK30/W33
	130	31	212	240	26,5	4 800	6 300	1,70	22215 E	22215 EK
	160	37	285	325	34,5	4 000	5 600	3,75	21315 E	21315 EK
	160	55	440	475	48	3 200	4 300	5,55	22315 E	22315 EK
80	140	33	236	270	29	4 300	6 000	2,10	22216 E	22216 EK
	170	39	325	375	39	3 800	5 300	4,45	21316 E	21316 EK
	170	58	490	540	54	3 000	4 000	6,60	22316 E	22316 EK

The designations of SKF Explorer bearings are printed in blue

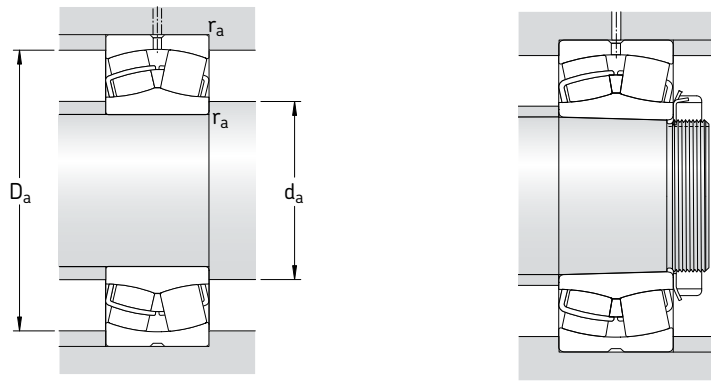

Dimensions

Abutment and fillet dimensions

Calculation factors

d	d ₂	D ₁	b	K	r _{1,2} min	d _a max	D _a max	r _a max	e	Y ₁	Y ₂	Y ₀
mm						mm			–			
20	31,2	44,2	3,7	2	1	25,6	46,4	1	0,35	1,9	2,9	1,8
25	31,2	44,2	3,7	2	1	30,6	46,4	1	0,35	1,9	2,9	1,8
	35,7	50,7	–	–	1,1	32	55	1	0,30	2,3	3,4	2,2
30	37,5	53	3,7	2	1	35,6	56,4	1	0,31	2,2	3,3	2,2
	43,3	58,8	–	–	1,1	37	65	1	0,27	2,5	3,7	2,5
35	44,5	61,8	3,7	2	1,1	42	65	1	0,31	2,2	3,3	2,2
	47,2	65,6	–	–	1,5	44	71	1,5	0,28	2,4	3,6	2,5
40	49,1	69,4	5,5	3	1,1	47	73	1	0,28	2,4	3,6	2,5
	59,9	79,8	5,5	3	1,5	49	81	1,5	0,24	2,8	4,2	2,8
	49,7	74,3	5,5	3	1,5	49	81	1,5	0,37	1,8	2,7	1,8
45	54,4	74,4	5,5	3	1,1	52	78	1	0,26	2,6	3,9	2,5
	65,3	88	5,5	3	1,5	54	91	1,5	0,24	2,8	4,2	2,8
	56,4	83,4	5,5	3	1,5	54	91	1,5	0,37	1,8	2,7	1,8
50	59,9	79	5,5	3	1,1	57	83	1	0,24	2,8	4,2	2,8
	71,6	96,8	5,5	3	2	61	99	2	0,24	2,8	4,2	2,8
	62,1	91,9	5,5	3	2	61	99	2	0,37	1,8	2,7	1,8
55	65,3	88	5,5	3	1,5	64	91	1,5	0,24	2,8	4,2	2,8
	71,6	96,2	5,5	3	2	66	109	2	0,24	2,8	4,2	2,8
	70,1	102	5,5	3	2	66	109	2	0,35	1,9	2,9	1,8
60	71,6	96,5	5,5	3	1,5	69	101	1,5	0,24	2,8	4,2	2,8
	87,8	115	5,5	3	2,1	72	118	2	0,22	3	4,6	2,8
	77,9	110	8,3	4,5	2,1	72	118	2	0,35	1,9	2,9	1,8
65	73,8	87,3	3,7	2	1,1	71	94	1	0,27	2,5	3,7	2,5
	77,6	106	5,5	3	1,5	74	111	1,5	0,24	2,8	4,2	2,8
	94,7	124	5,5	3	2,1	77	128	2	0,22	3	4,6	2,8
	81,6	118	8,3	4,5	2,1	77	128	2	0,35	1,9	2,9	1,8
70	83	111	5,5	3	1,5	79	116	1,5	0,23	2,9	4,4	2,8
	101	133	5,5	3	2,1	82	138	2	0,22	3	4,6	2,8
	90,3	128	8,3	4,5	2,1	82	138	2	0,33	2	3	2
75	84,1	100	5,5	3	1,1	81	109	1	0,28	2,4	3,6	2,5
	87,8	115	5,5	3	1,5	84	121	1,5	0,22	3	4,6	2,8
	101	133	5,5	3	2,1	87	148	2	0,22	3	4,6	2,8
	92,8	135	8,3	4,5	2,1	87	148	2	0,35	1,9	2,9	1,8
80	94,7	124	5,5	3	2	91	129	2	0,22	3	4,6	2,8
	106	141	5,5	3	2,1	92	158	2	0,24	2,8	4,2	2,8
	98,3	143	8,3	4,5	2,1	92	158	2	0,35	1,9	2,9	1,8

Spherical roller bearings
d 85 – 130 mm

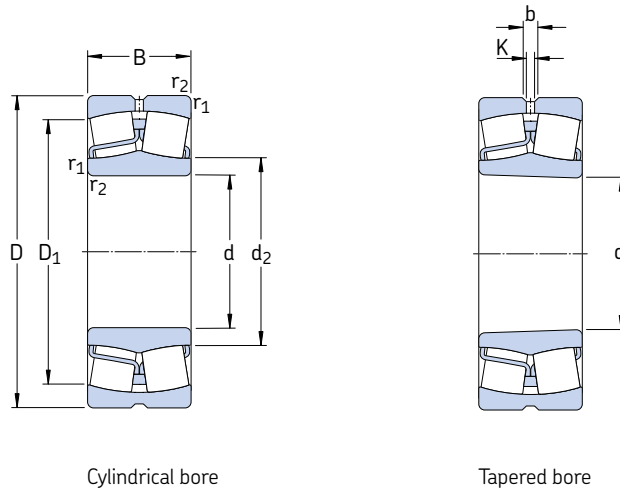

Cylindrical bore

Tapered bore

Principal dimensions			Basic load ratings		Fatigue load limit P_u	Speed ratings		Mass	Designations	
d	D	B	dynamic C	static C_0		Refer- ence speed	Limiting speed		Bearing with cylindrical bore	tapered bore
mm			kN		kN	r/min		kg	–	
85	150	36	285	325	34,5	4 000	5 600	2,65	22217 E	22217 EK
	180	41	325	375	39	3 800	5 300	5,20	21317 E	21317 EK
	180	60	550	620	61	2 800	3 800	7,65	22317 E	22317 EK
90	160	40	325	375	39	3 800	5 300	3,40	22218 E	22218 EK
	160	52,4	355	440	48	2 800	3 800	4,65	23218 CC/W33	23218 CCK/W33
	190	43	380	450	46,5	3 600	4 800	6,10	21318 E	21318 EK
	190	64	610	695	67	2 600	3 600	9,05	22318 E	22318 EK
95	170	43	380	450	46,5	3 600	4 800	4,15	22219 E	22219 EK
	200	45	425	490	49	3 400	4 500	7,05	21319 E	21319 EK
	200	67	670	765	73,5	2 600	3 400	10,5	22319 E	22319 EK
100	150	50	285	415	45,5	2 800	4 000	3,15	24020 CC/W33	24020 CCK30/W33
	165	52	365	490	53	3 000	4 000	4,55	23120 CC/W33	23120 CCK/W33
	165	65	455	640	68	2 400	3 200	5,65	24120 CC/W33	24120 CCK30/W33
	180	46	425	490	49	3 400	4 500	4,90	22220 E	22220 EK
110	180	60,3	475	600	63	2 400	3 400	6,85	23220 CC/W33	23220 CCK/W33
	215	47	425	490	49	3 400	4 500	8,60	21320 E	21320 EK
	215	73	815	950	88	2 400	3 000	13,5	22320 E	22320 EK
	170	45	310	440	46,5	3 400	4 300	3,80	23022 CC/W33	23022 CCK/W33
110	170	60	415	620	67	2 400	3 600	5,00	24022 CC/W33	24022 CCK30/W33
	180	56	430	585	61	2 800	3 600	5,75	23122 CC/W33	23122 CCK/W33
	180	69	520	750	78	2 200	3 000	7,10	24122 CC/W33	24122 CCK30/W33
	200	53	560	640	63	3 000	4 000	7,00	22222 E	22222 EK
120	200	69,8	600	765	76,5	2 200	3 200	9,85	23222 CC/W33	23222 CCK/W33
	240	80	950	1 120	100	2 000	2 800	18,4	22322 E	22322 EK
	180	46	355	510	53	3 200	4 000	4,20	23024 CC/W33	23024 CCK/W33
	180	60	430	670	68	2 400	3 400	5,45	24024 CC/W33	24024 CCK30/W33
120	200	62	510	695	71	2 600	3 400	8,00	23124 CC/W33	23124 CCK/W33
	200	80	655	950	95	1 900	2 600	10,3	24124 CC/W33	24124 CCK30/W33
	215	58	630	765	73,5	2 800	3 800	8,70	22224 E	22224 EK
	215	76	695	930	93	2 000	2 800	12,0	23224 CC/W33	23224 CCK/W33
130	260	86	965	1 120	100	2 000	2 600	23,0	22324 CC/W33	22324 CCK/W33
	200	52	430	610	62	2 800	3 600	6,00	23026 CC/W33	23026 CCK/W33
	200	69	540	815	81,5	2 000	3 000	8,05	24026 CC/W33	24026 CCK30/W33
	210	64	560	780	78	2 400	3 200	8,80	23126 CC/W33	23126 CCK/W33
130	210	80	680	1 000	100	1 800	2 400	11,0	24126 CC/W33	24126 CCK30/W33
	230	64	735	930	88	2 600	3 600	11,0	22226 E	22226 EK
	230	80	780	1 060	104	1 900	2 600	14,5	23226 CC/W33	23226 CCK/W33
	280	93	1 120	1 320	114	1 800	2 400	29,0	22326 CC/W33	22326 CCK/W33

The designations of SKF Explorer bearings are printed in blue

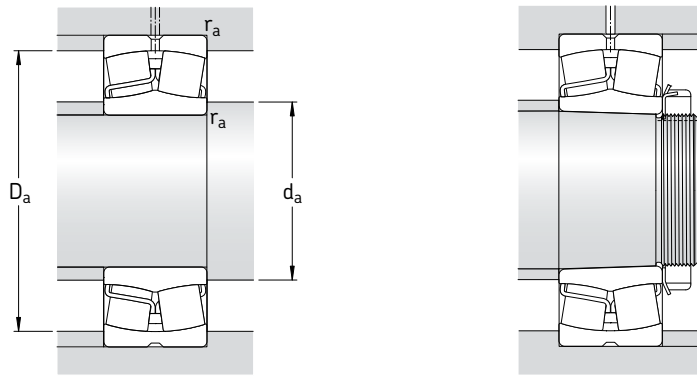

Dimensions

Abutment and fillet dimensions

Calculation factors

d	d ₂	D ₁	b	K	r _{1,2} min	d _a max	D _a max	r _a max	e	Y ₁	Y ₂	Y ₀
mm						mm			-			
85	101	133	5,5	3	2	96	139	2	0,22	3	4,6	2,8
	106	141	5,5	3	3	99	166	2,5	0,24	2,8	4,2	2,8
	108	154	8,3	4,5	3	99	166	2,5	0,33	2	3	2
90	106	141	5,5	3	2	101	149	2	0,24	2,8	4,2	2,8
	106	137	5,5	3	2	101	149	2	0,31	2,2	3,3	2,2
	112	150	8,3	4,5	3	104	176	2,5	0,24	2,8	4,2	2,8
	113	161	11,1	6	3	104	176	2,5	0,33	2	3	2
95	112	150	8,3	4,5	2,1	107	158	2	0,24	2,8	4,2	2,8
	118	159	8,3	4,5	3	109	186	2,5	0,24	2,8	4,2	2,8
	118	168	11,1	6	3	109	186	2,5	0,33	2	3	2
100	111	132	5,5	3	1,5	107	143	1,5	0,28	2,4	3,6	2,5
	115	144	5,5	3	2	111	154	2	0,30	2,3	3,4	2,2
	113	141	3,7	2	2	111	154	2	0,37	1,8	2,7	1,8
100	118	159	8,3	4,5	2,1	112	168	2	0,24	2,8	4,2	2,8
	117	153	8,3	4,5	2,1	112	168	2	0,33	2	3	2
	118	159	8,3	4,5	3	114	201	2,5	0,24	2,8	4,2	2,8
	130	184	11,1	6	3	114	201	2,5	0,33	2	3	2
	118	159	8,3	4,5	2,1	112	168	2	0,24	2,8	4,2	2,8
110	125	151	5,5	3	2	119	161	2	0,23	2,9	4,4	2,8
	122	149	5,5	3	2	119	161	2	0,33	2	3	2
	126	157	8,3	4,5	2	121	169	2	0,30	2,3	3,4	2,2
	123	153	5,5	3	2	121	169	2	0,37	1,8	2,7	1,8
110	130	178	8,3	4,5	2,1	122	188	2	0,25	2,7	4	2,5
	130	169	8,3	4,5	2,1	122	188	2	0,33	2	3	2
	143	204	13,9	7,5	3	124	226	2,5	0,33	2	3	2
	130	178	8,3	4,5	2,1	122	188	2	0,25	2,7	4	2,5
120	135	163	5,5	3	2	129	171	2	0,22	3	4,6	2,8
	132	159	5,5	3	2	129	171	2	0,30	2,3	3,4	2,2
	139	174	8,3	4,5	2	131	189	2	0,28	2,4	3,6	2,5
	135	168	5,5	3	2	131	189	2	0,37	1,8	2,7	1,8
	141	189	11,1	6	2,1	132	203	2	0,26	2,6	3,9	2,5
120	141	182	8,3	4,5	2,1	132	203	2	0,35	1,9	2,9	1,8
	152	216	13,9	7,5	3	134	246	2,5	0,35	1,9	2,9	1,8
	141	189	11,1	6	2,1	132	203	2	0,26	2,6	3,9	2,5
	152	216	13,9	7,5	3	134	246	2,5	0,35	1,9	2,9	1,8
130	148	180	8,3	4,5	2	139	191	2	0,23	2,9	4,4	2,8
	145	175	5,5	3	2	139	191	2	0,31	2,2	3,3	2,2
	148	184	8,3	4,5	2	141	199	2	0,28	2,4	3,6	2,5
	146	180	5,5	3	2	141	199	2	0,35	1,9	2,9	1,8
	152	201	11,1	6	3	144	216	2,5	0,27	2,5	3,7	2,5
130	151	196	8,3	4,5	3	144	216	2,5	0,33	2	3	2
	164	233	16,7	9	4	147	263	3	0,35	1,9	2,9	1,8



Spherical roller bearings
d 140 – 180 mm

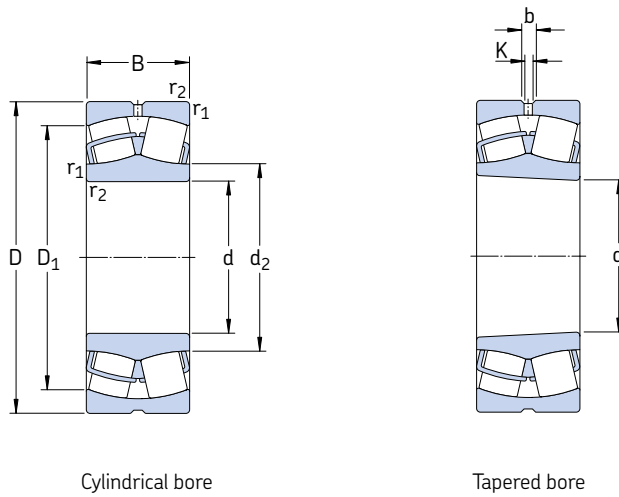

Cylindrical bore

Tapered bore

Principal dimensions			Basic load ratings		Fatigue load limit P_u	Speed ratings		Mass	Designations	
d	D	B	dynamic C	static C_0		Refer- ence speed	Limiting speed		Bearing with cylindrical bore	tapered bore
mm			kN		kN	r/min		kg	–	
140	210	53	465	680	68	2 600	3 400	6,55	23028 CC/W33	23028 CCK/W33
	210	69	570	900	88	2 000	2 800	8,55	24028 CC/W33	24028 CCK30/W33
	225	68	630	900	88	2 200	2 800	10,5	23128 CC/W33	23128 CCK/W33
	225	85	765	1 160	112	1 700	2 400	13,5	24128 CC/W33	24128 CCK30/W33
	250	68	710	900	86,5	2 400	3 200	14,0	22228 CC/W33	22228 CCK/W33
	250	88	915	1 250	120	1 700	2 400	19,0	23228 CC/W33	23228 CCK/W33
	300	102	1 290	1 560	132	1 700	2 200	36,5	22328 CC/W33	22328 CCK/W33
150	225	56	510	750	73,5	2 400	3 200	7,95	23030 CC/W33	23030 CCK/W33
	225	75	655	1 040	100	1 800	2 600	10,5	24030 CC/W33	24030 CCK30/W33
	250	80	830	1 200	114	2 000	2 600	16,0	23130 CC/W33	23130 CCK/W33
	250	100	1 020	1 530	146	1 500	2 200	20,0	24130 CC/W33	24130 CCK30/W33
	270	73	850	1 080	102	2 200	3 000	18,0	22230 CC/W33	22230 CCK/W33
	270	96	1 080	1 460	137	1 600	2 200	24,5	23230 CC/W33	23230 CCK/W33
	320	108	1 460	1 760	146	1 600	2 000	43,5	22330 CC/W33	22330 CCK/W33
160	240	60	585	880	83	2 400	3 000	9,70	23032 CC/W33	23032 CCK/W33
	240	80	750	1 200	114	1 700	2 400	13,0	24032 CC/W33	24032 CCK30/W33
	270	86	980	1 370	129	1 900	2 400	20,5	23132 CC/W33	23132 CCK/W33
	270	109	1 180	1 760	163	1 400	1 900	25,0	24132 CC/W33	24132 CCK30/W33
	290	80	1 000	1 290	118	2 000	2 800	22,5	22232 CC/W33	22232 CCK/W33
	290	104	1 220	1 660	153	1 500	2 200	31,0	23232 CC/W33	23232 CCK/W33
	340	114	1 600	1 960	160	1 500	1 900	52,0	22332 CC/W33	22332 CCK/W33
170	260	67	710	1 060	100	2 200	2 800	13,0	23034 CC/W33	23034 CCK/W33
	260	90	930	1 460	137	1 600	2 400	17,5	24034 CC/W33	24034 CCK30/W33
	280	88	1 040	1 500	137	1 800	2 400	22,0	23134 CC/W33	23134 CCK/W33
	280	109	1 220	1 860	170	1 300	1 900	27,5	24134 CC/W33	24134 CCK30/W33
	310	86	1 120	1 460	132	1 900	2 600	28,5	22234 CC/W33	22234 CCK/W33
	310	110	1 400	1 930	173	1 400	2 000	37,5	23234 CC/W33	23234 CCK/W33
	360	120	1 760	2 160	176	1 400	1 800	61,0	22334 CC/W33	22334 CCK/W33
180	250	52	431	830	76,5	2 200	2 800	7,90	23936 CC/W33	23936 CCK/W33
	280	74	830	1 250	114	2 000	2 600	17,0	23036 CC/W33	23036 CCK/W33
	280	100	1 080	1 730	156	1 500	2 200	23,0	24036 CC/W33	24036 CCK30/W33
	300	96	1 200	1 760	160	1 700	2 200	28,0	23136 CC/W33	23136 CCK/W33
	300	118	1 400	2 160	196	1 300	1 700	34,5	24136 CC/W33	24136 CCK30/W33
	320	86	1 180	1 560	140	1 800	2 600	29,5	22236 CC/W33	22236 CCK/W33
	320	112	1 500	2 120	186	1 300	1 900	39,5	23236 CC/W33	23236 CCK/W33
	380	126	2 000	2 450	193	1 300	1 700	71,5	22336 CC/W33	22336 CCK/W33

The designations of SKF Explorer bearings are printed in blue

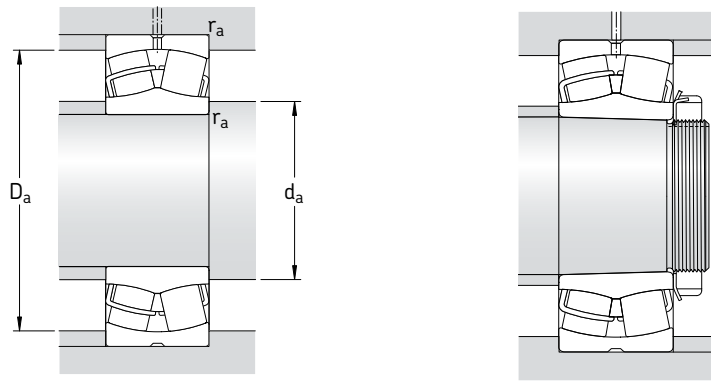

Dimensions

Abutment and fillet dimensions

Calculation factors

d	d ₂	D ₁	b	K	r _{1,2} min	d _a max	D _a max	r _a max	e	Y ₁	Y ₂	Y ₀
mm						mm			-			
140	158	190	8,3	4,5	2	149	201	2	0,22	3	4,6	2,8
	155	185	5,5	3	2	149	201	2	0,30	2,3	3,4	2,2
	159	197	8,3	4,5	2,1	152	213	2	0,28	2,4	3,6	2,5
	156	193	8,3	4,5	2,1	152	213	2	0,35	1,9	2,9	1,8
	166	216	11,1	6	3	154	236	2,5	0,26	2,6	3,9	2,5
	165	212	11,1	6	3	154	236	2,5	0,33	2	3	2
	175	247	16,7	9	4	157	283	3	0,35	1,9	2,9	1,8
150	169	203	8,3	4,5	2,1	161	214	2	0,22	3	4,6	2,8
	165	197	5,5	3	2,1	161	214	2	0,30	2,3	3,4	2,2
	172	216	11,1	6	2,1	162	238	2	0,30	2,3	3,4	2,2
	169	211	8,3	4,5	2,1	162	238	2	0,37	1,8	2,7	1,8
	178	234	13,9	7,5	3	164	256	2,5	0,26	2,6	3,9	2,5
	175	228	11,1	6	3	164	256	2,5	0,35	1,9	2,9	1,8
	188	266	16,7	9	4	167	303	3	0,35	1,9	2,9	1,8
160	180	217	11,1	6	2,1	171	229	2	0,22	3	4,6	2,8
	176	211	8,3	4,5	2,1	171	229	2	0,30	2,3	3,4	2,2
	184	234	13,9	7,5	2,1	172	258	2	0,30	2,3	3,4	2,2
	181	228	8,3	4,5	2,1	172	258	2	0,40	1,7	2,5	1,6
	191	250	13,9	7,5	3	174	276	2,5	0,26	2,6	3,9	2,5
	188	244	13,9	7,5	3	174	276	2,5	0,35	1,9	2,9	1,8
	200	282	16,7	9	4	177	323	3	0,35	1,9	2,9	1,8
170	191	232	11,1	6	2,1	181	249	2	0,23	2,9	4,4	2,8
	188	226	8,3	4,5	2,1	181	249	2	0,33	2	3	2
	195	244	13,9	7,5	2,1	182	268	2	0,30	2,3	3,4	2,2
	190	237	8,3	4,5	2,1	182	268	2	0,37	1,8	2,7	1,8
	203	267	16,7	9	4	187	293	3	0,27	2,5	3,7	2,5
	200	261	13,9	7,5	4	187	293	3	0,35	1,9	2,9	1,8
	213	300	16,7	9	4	187	343	3	0,33	2	3	2
180	199	231	5,5	3	2	189	241	2	0,18	3,8	5,6	3,6
	204	249	13,9	7,5	2,1	191	269	2	0,24	2,8	4,2	2,8
	201	243	8,3	4,5	2,1	191	269	2	0,33	2	3	2
	207	259	13,9	7,5	3	194	286	2,5	0,30	2,3	3,4	2,2
	203	253	11,1	6	3	194	286	2,5	0,37	1,8	2,7	1,8
	213	278	16,7	9	4	197	303	3	0,26	2,6	3,9	2,5
	211	271	13,9	7,5	4	197	303	3	0,35	1,9	2,9	1,8
224	317	22,3	12	4	197	363	3	0,35	1,9	2,9	1,8	

Spherical roller bearings

d 190 – 260 mm

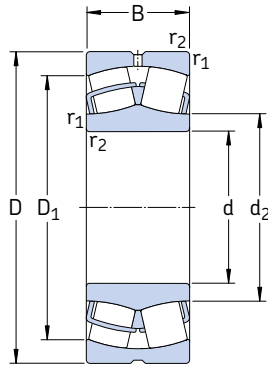

Cylindrical bore

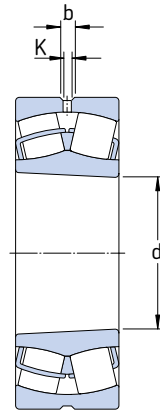

Tapered bore

Principal dimensions			Basic load ratings		Fatigue load limit P_u	Speed ratings		Mass	Designations	
d	D	B	dynamic C	static C_0		Refer- ence speed	Limiting speed		Bearing with cylindrical bore	tapered bore
mm			kN		kN	r/min		kg	–	
190	260	52	414	800	76,5	2 200	2 600	8,30	23938 CC/W33	23938 CCK/W33
	290	75	865	1 340	122	1 900	2 400	18,0	23038 CC/W33	23038 CCK/W33
	290	100	1 120	1 800	163	1 400	2 000	24,5	24038 CC/W33	24038 CCK30/W33
	320	104	1 370	2 080	183	1 500	2 000	35,0	23138 CC/W33	23138 CCK/W33
	320	128	1 600	2 500	212	1 200	1 600	43,0	24138 CC/W33	24138 CCK30/W33
	340	92	1 270	1 700	150	1 700	2 400	36,5	22238 CC/W33	22238 CCK/W33
	340	120	1 660	2 400	208	1 300	1 800	48,0	23238 CC/W33	23238 CCK/W33
	400	132	2 120	2 650	208	1 200	1 600	82,5	22338 CC/W33	22338 CCK/W33
200	280	60	546	1 040	93	2 000	2 400	11,5	23940 CC/W33	23940 CCK/W33
	310	82	1 000	1 530	137	1 800	2 200	23,3	23040 CC/W33	23040 CCK/W33
	310	109	1 290	2 120	186	1 300	1 900	31,0	24040 CC/W33	24040 CCK30/W33
	340	112	1 600	2 360	204	1 500	1 900	43,0	23140 CC/W33	23140 CCK/W33
	340	140	1 800	2 800	232	1 100	1 500	53,5	24140 CC/W33	24140 CCK30/W33
	360	98	1 460	1 930	166	1 600	2 200	43,5	22240 CC/W33	22240 CCK/W33
220	360	128	1 860	2 700	228	1 200	1 700	58,0	23240 CC/W33	23240 CCK/W33
	420	138	2 320	2 900	224	1 200	1 500	95,0	22340 CC/W33	22340 CCK/W33
	300	60	546	1 080	93	1 900	2 200	12,5	23944 CC/W33	23944 CCK/W33
	340	90	1 220	1 860	163	1 600	2 000	30,5	23044 CC/W33	23044 CCK/W33
	340	118	1 560	2 600	212	1 200	1 700	40,0	24044 CC/W33	24044 CCK30/W33
	370	120	1 800	2 750	232	1 300	1 700	53,5	23144 CC/W33	23144 CCK/W33
240	370	150	2 120	3 350	285	1 000	1 400	67,0	24144 CC/W33	24144 CCK30/W33
	400	108	1 760	2 360	196	1 500	2 000	60,5	22244 CC/W33	22244 CCK/W33
	400	144	2 360	3 450	285	1 100	1 500	81,5	23244 CC/W33	23244 CCK/W33
	460	145	2 700	3 450	260	1 000	1 400	120	22344 CC/W33	22344 CCK/W33
	320	60	564	1 160	98	1 700	2 000	13,5	23948 CC/W33	23948 CCK/W33
	360	92	1 290	2 080	176	1 500	1 900	33,5	23048 CC/W33	23048 CCK/W33
260	360	118	1 600	2 700	228	1 100	1 600	43,0	24048 CC/W33	24048 CCK30/W33
	400	128	2 080	3 200	255	1 200	1 600	66,5	23148 CC/W33	23148 CCK/W33
	400	160	2 400	3 900	320	900	1 300	83,0	24148 CC/W33	24148 CCK30/W33
	440	120	2 200	3 000	245	1 300	1 800	83,0	22248 CC/W33	22248 CCK/W33
	440	160	2 900	4 300	345	950	1 300	110	23248 CC/W33	23248 CCK/W33
	500	155	3 100	4 000	290	950	1 300	155	22348 CC/W33	22348 CCK/W33
260	360	75	880	1 800	156	1 500	1 900	23,5	23952 CC/W33	23952 CCK/W33
	400	104	1 600	2 550	212	1 300	1 700	48,5	23052 CC/W33	23052 CCK/W33
	400	140	2 040	3 450	285	1 000	1 400	65,5	24052 CC/W33	24052 CCK30/W33
	440	144	2 550	3 900	290	1 100	1 400	90,5	23152 CC/W33	23152 CCK/W33
	440	180	3 000	4 800	380	850	1 200	110	24152 CC/W33	24152 CCK30/W33
	480	130	2 650	3 550	285	1 200	1 600	110	22252 CC/W33	22252 CCK/W33
	480	174	3 250	4 750	360	850	1 200	140	23252 CC/W33	23252 CCK/W33
	540	165	3 550	4 550	325	850	1 100	190	22352 CC/W33	22352 CCK/W33

The designations of SKF Explorer bearings are printed in blue

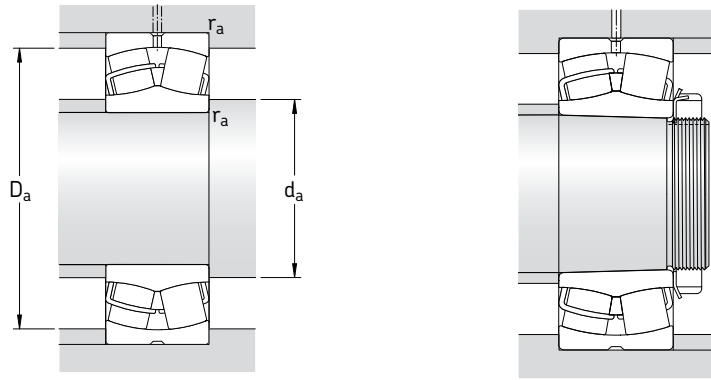

Dimensions

Abutment and fillet dimensions

Calculation factors

d	d ₂	D ₁	b	K	r _{1,2} min	d _a max	D _a max	r _a max	e	Y ₁	Y ₂	Y ₀	
mm						mm			-				
190	209	240	5,5	3	2	199	251	2	0,16	4,2	6,3	4	
	216	261	13,9	7,5	2,1	201	279	2	0,23	2,9	4,4	2,8	
	210	253	8,3	4,5	2,1	201	279	2	0,31	2,2	3,3	2,2	
	220	275	13,9	7,5	3	204	306	2,5	0,31	2,2	3,3	2,2	
	215	268	11,1	6	3	204	306	2,5	0,40	1,7	2,5	1,6	
	225	294	16,7	9	4	207	323	3	0,26	2,6	3,9	2,5	
	222	287	16,7	9	4	207	323	3	0,35	1,9	2,9	1,8	
	236	333	22,3	12	5	210	380	4	0,35	1,9	2,9	1,8	
	200	222	258	8,3	4,5	2,1	211	269	2	0,19	3,6	5,3	3,6
		228	278	13,9	7,5	2,1	211	299	2	0,24	2,8	4,2	2,8
223		268	11,1	6	2,1	211	299	2	0,33	2	3	2	
231		293	16,7	9	3	214	326	2,5	0,31	2,2	3,3	2,2	
226		284	11,1	6	3	214	326	2,5	0,40	1,7	2,5	1,6	
238		313	16,7	9	4	217	343	3	0,26	2,6	3,9	2,5	
235		304	16,7	9	4	217	343	3	0,35	1,9	2,9	1,8	
248		351	22,3	12	5	220	400	4	0,33	2	3	2	
220		241	278	8,3	4,5	2,1	231	289	2	0,16	4,2	6,3	4
		250	306	13,9	7,5	3	233	327	2,5	0,24	2,8	4,2	2,8
	244	295	11,1	6	3	233	327	2,5	0,33	2	3	2	
	255	320	16,7	9	4	237	353	3	0,30	2,3	3,4	2,2	
	248	310	11,1	6	4	237	353	3	0,40	1,7	2,5	1,6	
	263	346	16,7	9	4	237	383	3	0,27	2,5	3,7	2,5	
	259	338	16,7	9	4	237	383	3	0,35	1,9	2,9	1,8	
	279	389	22,3	12	5	240	440	4	0,31	2,2	3,3	2,2	
	240	261	298	8,3	4,5	2,1	251	309	2	0,15	4,5	6,7	4,5
		271	326	13,9	7,5	3	253	347	2,5	0,23	2,9	4,4	2,8
265		316	11,1	6	3	253	347	2,5	0,30	2,3	3,4	2,2	
277		348	16,7	9	4	257	383	3	0,30	2,3	3,4	2,2	
271		336	11,1	6	4	257	383	3	0,40	1,7	2,5	1,6	
290		383	22,3	12	4	257	423	3	0,27	2,5	3,7	2,5	
286		374	22,3	12	4	257	423	3	0,35	1,9	2,9	1,8	
303		423	22,3	12	5	260	480	4	0,31	2,2	3,3	2,2	
260		287	331	8,3	4,5	2,1	271	349	2	0,18	3,8	5,6	3,6
		295	360	16,7	9	4	275	385	3	0,23	2,9	4,4	2,8
	289	347	11,1	6	4	275	385	3	0,33	2	3	2	
	301	380	16,7	9	4	277	423	3	0,31	2,2	3,3	2,2	
	293	368	13,9	7,5	4	277	423	3	0,40	1,7	2,5	1,6	
	311	421	22,3	12	5	280	460	4	0,27	2,5	3,7	2,5	
	312	408	22,3	12	5	280	460	4	0,35	1,9	2,9	1,8	
	328	458	22,3	12	6	286	514	5	0,31	2,2	3,3	2,2	



Spherical roller bearings
d 280 – 360 mm

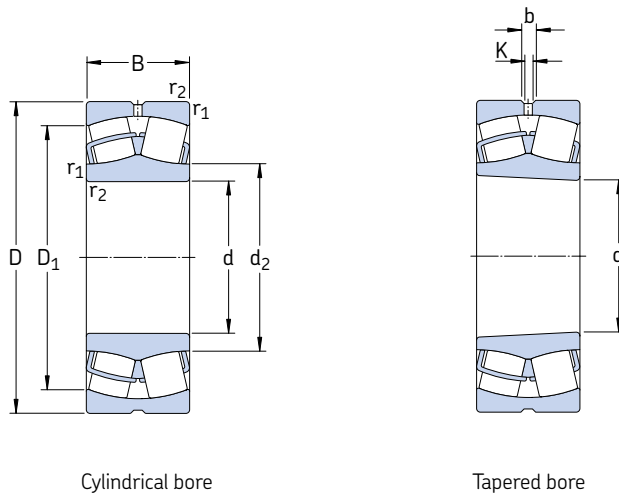

Cylindrical bore

Tapered bore

Principal dimensions			Basic load ratings		Fatigue load limit P_u	Speed ratings		Mass	Designations	
d	D	B	dynamic C	static C_0		Refer- ence speed	Limiting speed		Bearing with cylindrical bore	tapered bore
mm			kN		kN	r/min		kg	–	
280	380	75	845	1 760	143	1 400	1 700	25,0	23956 CC/W33	23956 CCK/W33
	420	106	1 730	2 850	224	1 300	1 600	52,5	23056 CC/W33	23056 CCK/W33
	420	140	2 160	3 800	285	950	1 400	69,5	24056 CC/W33	24056 CCK30/W33
	460	146	2 650	4 250	335	1 000	1 300	97,0	23156 CC/W33	23156 CCK/W33
	460	180	3 100	5 100	415	800	1 100	120	24156 CC/W33	24156 CCK30/W33
	500	130	2 700	3 750	300	1 100	1 500	115	22256 CC/W33	22256 CCK/W33
	500	176	3 250	4 900	365	800	1 100	150	23256 CC/W33	23256 CCK/W33
580	175	4 000	5 200	365	800	1 100	235	22356 CC/W33	22356 CCK/W33	
300	380	60	656	1 600	137	1 400	1 700	16,5	23860 CAMA	23860 CAKMA
	420	90	1 200	2 500	200	1 300	1 600	39,5	23960 CC/W33	23960 CCK/W33
	460	118	2 120	3 450	265	1 200	1 500	71,5	23060 CC/W33	23060 CCK/W33
	460	160	2 700	4 750	355	850	1 200	97,0	24060 CC/W33	24060 CCK30/W33
	500	160	3 200	5 100	380	950	1 200	125	23160 CC/W33	23160 CCK/W33
	500	200	3 750	6 300	465	700	1 000	160	24160 CC/W33	24160 CCK30/W33
	540	140	3 150	4 250	325	1 000	1 400	145	22260 CC/W33	22260 CCK/W33
540	192	3 900	5 850	425	750	1 000	190	23260 CC/W33	23260 CCK/W33	
320	440	90	1 430	2 700	212	1 400	1 500	42,0	23964 CC/W33	23964 CCK/W33
	480	121	2 240	3 800	285	1 100	1 400	78,0	23064 CC/W33	23064 CCK/W33
	480	160	2 850	5 100	400	800	1 200	100	24064 CC/W33	24064 CCK30/W33
	540	176	3 750	6 000	440	850	1 100	165	23164 CC/W33	23164 CCK/W33
	540	218	4 250	7 100	510	670	900	210	24164 CC/W33	24164 CCK30/W33
	580	150	3 600	4 900	375	950	1 300	175	22264 CC/W33	22264 CCK/W33
	580	208	4 400	6 700	480	700	950	240	23264 CC/W33	23264 CCK/W33
340	460	90	1 460	2 800	216	1 300	1 400	45,5	23968 CC/W33	23968 CCK/W33
	520	133	2 700	4 550	335	1 000	1 300	105	23068 CC/W33	23068 CCK/W33
	520	180	3 450	6 200	475	750	1 100	140	24068 CC/W33	24068 CCK30/W33
	580	190	4 250	6 800	480	800	1 000	210	23168 CC/W33	23168 CCK/W33
	580	243	5 300	8 650	630	600	850	280	24168 ECCJ/W33	24168 ECCK30J/W33
	620	224	5 100	7 800	550	560	800	295	23268 CA/W33	23268 CAK/W33
	620	224	5 100	7 800	550	560	800	295	23268 CA/W33	23268 CAK/W33
360	480	90	1 400	2 750	220	1 200	1 300	46,0	23972 CC/W33	23972 CCK/W33
	540	134	2 750	4 800	345	950	1 200	110	23072 CC/W33	23072 CCK/W33
	540	180	3 550	6 550	490	700	1 000	145	24072 CC/W33	24072 CCK30/W33
	600	192	4 300	6 950	490	750	1 000	220	23172 CC/W33	23172 CCK/W33
	600	243	5 600	9 300	670	560	800	280	24172 ECCJ/W33	24172 ECCK30J/W33
	650	170	4 300	6 200	440	630	850	255	22272 CA/W33	22272 CAK/W33
	650	232	5 400	8 300	570	530	750	335	23272 CA/W33	23272 CAK/W33

The designations of SKF Explorer bearings are printed in blue

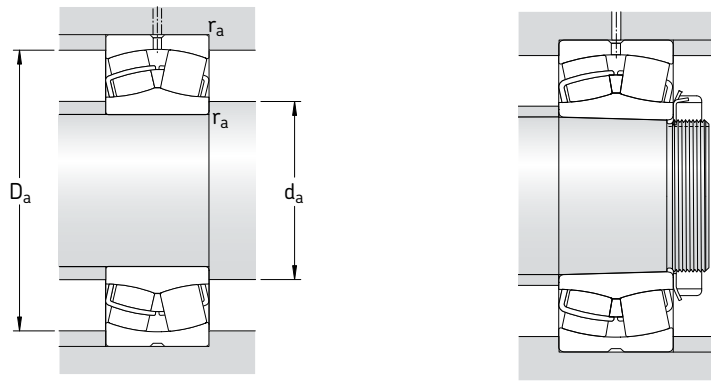

Dimensions

Abutment and fillet dimensions

Calculation factors

d	d ₂	D ₁	b	K	r _{1,2} min	d _a max	D _a max	r _a max	e	Y ₁	Y ₂	Y ₀	
mm						mm			–				
280	308	352	11,1	6	2,1	291	369	2	0,16	4,2	6,3	4	
	315	380	16,7	9	4	295	405	3	0,23	2,9	4,4	2,8	
	309	368	11,1	6	4	295	405	3	0,31	2,2	3,3	2,2	
	321	401	16,7	9	5	300	440	4	0,30	2,3	3,4	2,2	
	314	390	13,9	7,5	5	300	440	4	0,40	1,7	2,5	1,6	
	333	441	22,3	12	5	300	480	4	0,26	2,6	3,9	2,5	
	332	429	22,3	12	5	300	480	4	0,35	1,9	2,9	1,8	
	354	492	22,3	12	6	306	554	5	0,30	2,3	3,4	2,2	
	300	329	358	–	–	2,1	311	369	2	0,13	5,2	7,7	5
		333	385	11,1	6	3	313	407	2,5	0,19	3,6	5,3	3,6
340		414	16,7	9	4	315	445	3	0,23	2,9	4,4	2,8	
331		400	13,9	7,5	4	315	445	3	0,33	2	3	2	
345		434	16,7	9	5	320	480	4	0,30	2,3	3,4	2,2	
338		422	13,9	7,5	5	320	480	4	0,40	1,7	2,5	1,6	
354		477	22,3	12	5	320	520	4	0,26	2,6	3,9	2,5	
356		461	22,3	12	5	320	520	4	0,35	1,9	2,9	1,8	
320		354	406	11,1	6	3	333	427	2,5	0,17	4	5,9	4
		360	434	16,7	9	4	335	465	3	0,23	2,9	4,4	2,8
	354	423	13,9	7,5	4	335	465	3	0,31	2,2	3,3	2,2	
	370	465	22,3	12	5	340	520	4	0,31	2,2	3,3	2,2	
	364	455	16,7	9	5	340	520	4	0,40	1,7	2,5	1,6	
	379	513	22,3	12	5	340	560	4	0,26	2,6	3,9	2,5	
	382	493	22,3	12	5	340	560	4	0,35	1,9	2,9	1,8	
	340	373	426	11,1	6	3	353	447	2,5	0,17	4	5,9	4
		385	468	22,3	12	5	358	502	4	0,24	2,8	4,2	2,8
		377	453	16,7	9	5	358	502	4	0,33	2	3	2
394		498	22,3	12	5	360	560	4	0,31	2,2	3,3	2,2	
383		491	16,7	9	5	360	560	4	0,40	1,7	2,5	1,6	
426		528	22,3	12	6	366	594	5	0,35	1,9	2,9	1,8	
360		394	447	11,1	6	3	373	467	2,5	0,15	4,5	6,7	4,5
		404	483	22,3	12	5	378	522	4	0,23	2,9	4,4	2,8
		397	474	16,7	9	5	378	522	4	0,31	2,2	3,3	2,2
		418	524	22,3	12	5	380	580	4	0,30	2,3	3,4	2,2
	404	511	16,7	9	5	380	580	4	0,40	1,7	2,5	1,6	
	453	568	22,3	12	6	386	624	5	0,26	2,6	3,9	2,5	
	447	552	22,3	12	6	386	624	5	0,35	1,9	2,9	1,8	



Spherical roller bearings
d 380 – 480 mm

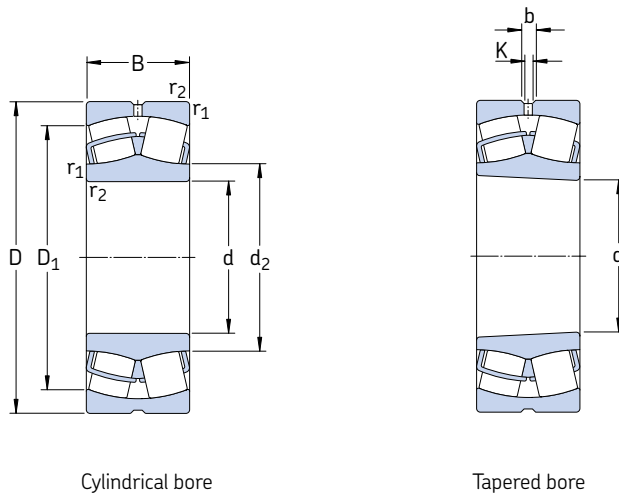

Cylindrical bore

Tapered bore

Principal dimensions			Basic load ratings		Fatigue load limit P_u	Speed ratings		Mass	Designations	
d	D	B	dynamic C	static C_0		Refer- ence speed	Limiting speed		Bearing with cylindrical bore	tapered bore
mm			kN		kN	r/min		kg	–	
380	520	106	1 960	3 800	285	1 100	1 200	69,0	23976 CC/W33	23976 CCK/W33
	560	135	2 900	5 000	360	900	1 200	115	23076 CC/W33	23076 CCK/W33
	560	180	3 600	6 800	480	670	950	150	24076 CC/W33	24076 CCK30/W33
	620	194	4 400	7 100	500	560	1 000	230	23176 CA/W33	23176 CAK/W33
400	620	243	5 700	9 800	710	480	850	300	24176 ECA/W33	24176 ECAK30/W33
	680	240	5 850	9 150	620	500	750	375	23276 CA/W33	23276 CAK/W33
	540	106	2 000	3 900	290	1 100	1 200	71,0	23980 CC/W33	23980 CCK/W33
	600	148	3 250	5 700	400	850	1 100	150	23080 CC/W33	23080 CCK/W33
420	600	200	4 300	8 000	560	630	900	205	24080 ECCJ/W33	24080 ECCK30J/W33
	650	200	4 650	7 650	530	530	950	265	23180 CA/W33	23180 CAK/W33
	650	250	6 200	10 600	735	430	800	340	24180 ECA/W33	24180 ECAK30/W33
	720	256	6 550	10 400	680	480	670	450	23280 CA/W33	23280 CAK/W33
	820	243	7 500	10 400	670	430	750	650	22380 CA/W33	22380 CAK/W33
	560	106	2 040	4 150	300	1 000	1 100	74,5	23984 CC/W33	23984 CCK/W33
440	620	150	3 400	6 000	415	600	1 100	155	23084 CA/W33	23084 CAK/W33
	620	200	4 400	8 300	585	530	900	210	24084 ECA/W33	24084 ECAK30/W33
	700	224	5 600	9 300	620	480	900	350	23184 CJ/W33	23184 CKJ/W33
	700	280	7 350	12 600	850	400	700	445	24184 ECA/W33	24184 ECAK30/W33
460	760	272	7 350	11 600	765	450	630	535	23284 CA/W33	23284 CAK/W33
	600	118	2 450	4 900	345	950	1 000	99,5	23988 CC/W33	23988 CCK/W33
	650	157	3 650	6 550	450	560	1 000	180	23088 CA/W33	23088 CAK/W33
	650	212	4 800	9 150	630	500	850	245	24088 ECA/W33	24088 ECAK30/W33
480	720	226	6 000	10 000	670	450	850	360	23188 CA/W33	23188 CAK/W33
	720	280	7 500	13 200	900	400	700	460	24188 ECA/W33	24188 ECAK30/W33
	790	280	7 800	12 500	800	430	600	590	23288 CA/W33	23288 CAK/W33
	580	118	1 790	4 900	345	560	1 100	75,5	24892 CAMA/W20	24892 CAK30MA/W20
460	620	118	2 500	5 000	355	600	1 000	105	23992 CA/W33	23992 CAK/W33
	680	163	3 900	6 950	465	560	950	205	23092 CA/W33	23092 CAK/W33
	680	218	5 200	10 000	670	480	800	275	24092 ECA/W33	24092 ECAK30/W33
	760	240	6 400	10 800	680	430	800	440	23192 CA/W33	23192 CAK/W33
480	760	300	8 300	14 600	1 000	360	670	560	24192 ECA/W33	24192 ECAK30/W33
	830	296	8 500	13 700	880	400	560	695	23292 CA/W33	23292 CAK/W33
	600	90	1 440	3 750	280	530	1 100	61,0	23896 CAMA/W20	23896 CAKMA/W20
	650	128	2 900	5 700	405	560	1 000	125	23996 CA/W33	23996 CAK/W33
480	700	165	3 900	6 800	450	530	950	215	23096 CA/W33	23096 CAK/W33
	700	218	5 300	10 400	695	450	750	285	24096 ECA/W33	24096 ECAK30/W33
	790	248	6 950	12 000	780	400	750	485	23196 CA/W33	23196 CAK/W33
	790	308	9 000	15 600	1 040	340	630	605	24196 ECA/W33	24196 ECAK30/W33
	870	310	9 300	15 000	950	380	530	800	23296 CA/W33	23296 CAK/W33

The designations of SKF Explorer bearings are printed in blue

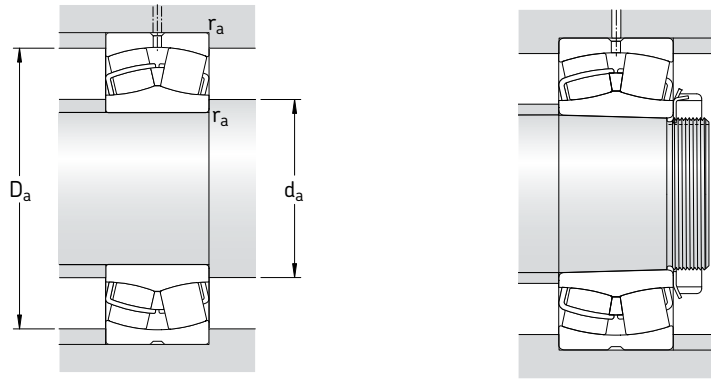

Dimensions

Abutment and fillet dimensions

Calculation factors

d	d ₂	D ₁	b	K	r _{1,2} min	d _a max	D _a max	r _a max	e	Y ₁	Y ₂	Y ₀
mm						mm			-			
380	419	481	13,9	7,5	4	395	505	3	0,17	4	5,9	4
	426	509	22,3	12	5	398	542	4	0,22	3	4,6	2,8
	419	497	16,7	9	5	398	542	4	0,30	2,3	3,4	2,2
	452	541	22,3	12	5	400	600	4	0,30	2,3	3,4	2,2
	442	532	16,7	9	5	400	600	4	0,37	1,8	2,7	1,8
400	471	581	22,3	12	6	406	654	5	0,35	1,9	2,9	1,8
	439	500	13,9	7,5	4	415	525	3	0,16	4,2	6,3	4
	450	543	22,3	12	5	418	582	4	0,23	2,9	4,4	2,8
	442	527	22,3	12	5	418	582	4	0,30	2,3	3,4	2,2
	474	566	22,3	12	6	426	624	5	0,28	2,4	3,6	2,5
420	465	559	22,3	12	6	426	624	5	0,37	1,8	2,7	1,8
	499	615	22,3	12	6	426	694	5	0,35	1,9	2,9	1,8
	534	697	22,3	12	7,5	432	788	6	0,30	2,3	3,4	2,2
	459	520	16,7	9	4	435	545	3	0,16	4,2	6,3	4
	485	563	22,3	12	5	438	602	4	0,22	3	4,6	2,8
440	476	547	22,3	12	5	438	602	4	0,30	2,3	3,4	2,2
	483	607	22,3	12	6	446	674	5	0,30	2,3	3,4	2,2
	494	597	22,3	12	6	446	674	5	0,40	1,7	2,5	1,6
	525	649	22,3	12	7,5	452	728	6	0,35	1,9	2,9	1,8
	484	553	16,7	9	4	455	585	3	0,16	4,2	6,3	4
460	509	590	22,3	12	6	463	627	5	0,22	3	4,6	2,8
	498	572	22,3	12	6	463	627	5	0,30	2,3	3,4	2,2
	528	632	22,3	12	6	466	694	5	0,30	2,3	3,4	2,2
	516	618	22,3	12	6	466	694	5	0,37	1,8	2,7	1,8
	547	676	22,3	12	7,5	472	758	6	0,35	1,9	2,9	1,8
480	505	541	-	6	3	473	567	2,5	0,17	4	5,9	4
	512	574	16,7	9	4	475	605	3	0,16	4,2	6,3	4
	531	617	22,3	12	6	483	657	5	0,22	3	4,6	2,8
	523	601	22,3	12	6	483	657	5	0,28	2,4	3,6	2,5
	553	666	22,3	12	7,5	492	728	6	0,30	2,3	3,4	2,2
480	544	649	22,3	12	7,5	492	728	6	0,37	1,8	2,7	1,8
	572	706	22,3	12	7,5	492	798	6	0,35	1,9	2,9	1,8
	521	566	-	7,5	3	493	587	2,5	0,13	5,2	7,7	5
	532	602	16,7	9	5	498	632	4	0,18	3,8	5,6	3,6
	547	633	22,3	12	6	503	677	5	0,21	3,2	4,8	3,2
480	541	619	22,3	12	6	503	677	5	0,28	2,4	3,6	2,5
	577	692	22,3	12	7,5	512	758	6	0,30	2,3	3,4	2,2
	564	678	22,3	12	7,5	512	758	6	0,37	1,8	2,7	1,8
	600	741	22,3	12	7,5	512	838	6	0,35	1,9	2,9	1,8



Spherical roller bearings
d 500 – 630 mm

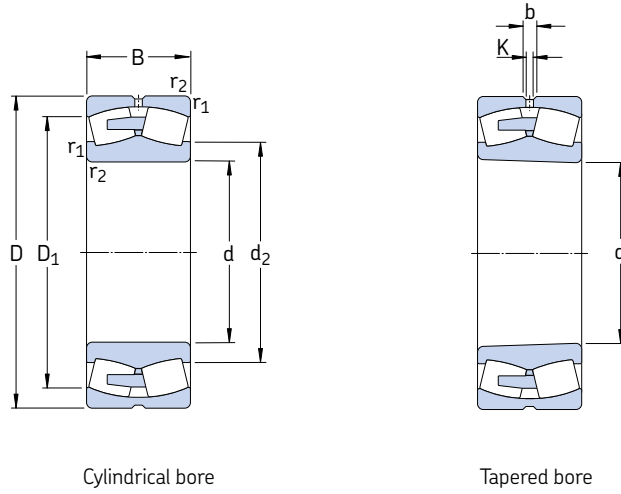

Cylindrical bore

Tapered bore

Principal dimensions			Basic load ratings		Fatigue load limit P_u	Speed ratings		Mass	Designations	
d	D	B	dynamic C	static C_0		Refer- ence speed	Limiting speed		Bearing with cylindrical bore	tapered bore
mm			kN		kN	r/min		kg	–	
500	620	90	1 480	4 000	290	530	1 000	62,0		238/500 CAMA/W20 238/500 CAKMA/W20
	670	128	2 900	6 000	415	530	950	130		239/500 CA/W33 239/500 CAK/W33
	720	167	4 150	7 800	510	500	900	225		230/500 CA/W33 230/500 CAK/W33
	720	218	5 500	11 000	735	430	700	295		240/500 ECA/W33 240/500 ECAK30/W33
	830	264	7 650	12 900	830	380	700	580		231/500 CA/W33 231/500 CAK/W33
530	830	325	9 800	17 000	1 120	320	600	700		241/500 ECA/W33 241/500 ECAK30/W33
	920	336	10 600	17 300	1 060	360	500	985		232/500 CA/W33 232/500 CAK/W33
	650	118	1 840	5 300	380	480	950	86,0		248/530 CAMA/W20 248/530 CAK30MA/W20
	710	136	3 200	6 700	480	500	900	155		239/530 CA/W33 239/530 CAK/W33
	780	185	5 100	9 300	630	450	800	310		230/530 CA/W33 230/530 CAK/W33
560	780	250	6 700	13 200	830	400	670	410		240/530 ECA/W33 240/530 ECAK30/W33
	870	272	8 150	14 000	915	360	670	645		231/530 CA/W33 231/530 CAK/W33
	870	335	10 600	19 000	1 220	300	560	830		241/530 ECA/W33 241/530 ECAK30/W33
	980	355	11 100	20 400	1 220	300	480	1 200		232/530 CA/W33 232/530 CAK/W33
	750	140	3 450	7 200	510	450	850	175		239/560 CA/W33 239/560 CAK/W33
600	820	195	5 600	10 200	680	430	750	355		230/560 CA/W33 230/560 CAK/W33
	820	258	7 350	14 600	960	380	630	465		240/560 ECA/W33 240/560 ECAK30/W33
	920	280	9 150	16 000	980	340	630	740		231/560 CA/W33 231/560 CAK/W33
	920	355	12 000	21 600	1 340	280	500	985		241/560 ECJ/W33 241/560 ECK30J/W33
	1 030	365	11 500	22 000	1 400	280	430	1 350		232/560 CA/W33 232/560 CAK/W33
630	800	150	3 900	8 300	585	430	750	220		239/600 CA/W33 239/600 CAK/W33
	870	200	6 000	11 400	750	400	700	405		230/600 CA/W33 230/600 CAK/W33
	870	272	8 150	17 000	1 100	340	560	520		240/600 ECA/W33 240/600 ECAK30/W33
	980	300	10 200	18 000	1 100	320	560	895		231/600 CA/W33 231/600 CAK/W33
	980	375	11 500	23 600	1 460	240	480	1 200		241/600 ECA/W33 241/600 ECAK30/W33
630	1 090	388	13 100	25 500	1 560	260	400	1 600		232/600 CA/W33 232/600 CAK/W33
	780	112	2 190	6 100	415	400	750	120		238/630 CAMA/W20 238/630 CAKMA/W20
	850	165	4 650	9 800	640	400	700	280		239/630 CA/W33 239/630 CAK/W33
	920	212	6 700	12 500	800	380	670	485		230/630 CA/W33 230/630 CAK/W33
	920	290	8 800	18 000	1 140	320	530	645		240/630 ECJ/W33 240/630 ECK30J/W33
630	1 030	315	10 500	20 800	1 220	260	530	1 050		231/630 CA/W33 231/630 CAK/W33
	1 030	400	12 700	27 000	1 630	220	450	1 400		241/630 ECA/W33 241/630 ECAK30/W33

The designations of SKF Explorer bearings are printed in blue

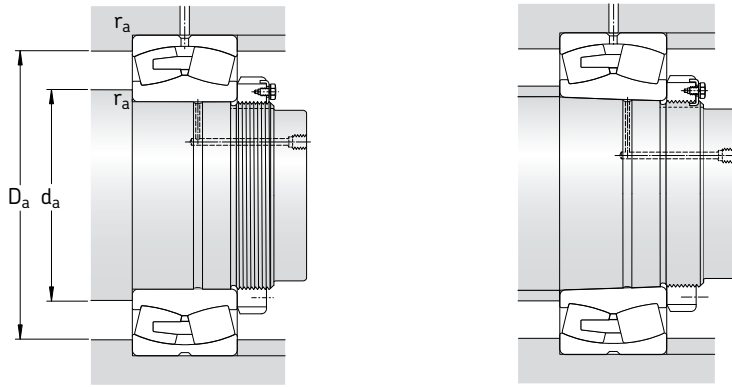

Dimensions

Abutment and fillet dimensions

Calculation factors

d	d ₂	D ₁	b	K	r _{1,2} min	d _a max	D _a max	r _a max	e	Y ₁	Y ₂	Y ₀
mm						mm			-			
500	543	587	-	7,5	3	513	607	2,5	0,12	5,6	8,4	5,6
	557	622	22,3	12	5	518	652	4	0,17	4	5,9	4
	571	658	22,3	12	6	523	697	5	0,21	3,2	4,8	3,2
	565	644	22,3	12	6	523	697	5	0,26	2,6	3,9	2,5
	603	726	22,3	12	7,5	532	798	6	0,30	2,3	3,4	2,2
	589	713	22,3	12	7,5	532	798	6	0,37	1,8	2,7	1,8
631	779	22,3	12	7,5	532	888	6	0,35	1,9	2,9	1,8	
530	573	612	-	7,5	3	543	637	2,5	0,15	4,5	6,7	4,5
	589	661	22,3	12	5	548	692	4	0,17	4	5,9	4
	611	710	22,3	12	6	553	757	5	0,22	3	4,6	2,8
	600	687	22,3	12	6	553	757	5	0,28	2,4	3,6	2,5
	636	763	22,3	12	7,5	562	838	6	0,30	2,3	3,4	2,2
	623	748	22,3	12	7,5	562	838	6	0,37	1,8	2,7	1,8
668	836	22,3	12	9,5	570	940	8	0,35	1,9	2,9	1,8	
560	625	697	22,3	12	5	578	732	4	0,16	4,2	6,3	4
	644	746	22,3	12	6	583	797	5	0,22	3	4,6	2,8
	635	728	22,3	12	6	583	797	5	0,28	2,4	3,6	2,5
	673	809	22,3	12	7,5	592	888	6	0,30	2,3	3,4	2,2
	634	796	22,3	12	7,5	592	888	6	0,35	1,9	2,9	1,8
	704	878	22,3	12	9,5	600	990	8	0,35	1,9	2,9	1,8
600	668	744	22,3	12	5	618	782	4	0,17	4	5,9	4
	683	789	22,3	12	6	623	847	5	0,22	3	4,6	2,8
	675	774	22,3	12	6	623	847	5	0,30	2,3	3,4	2,2
	720	863	22,3	12	7,5	632	948	6	0,30	2,3	3,4	2,2
	702	845	22,3	12	7,5	632	948	6	0,37	1,8	2,7	1,8
	752	929	22,3	12	9,5	640	1050	8	0,35	1,9	2,9	1,8
630	681	738	-	9	4	645	765	3	0,12	5,6	8,4	5,6
	705	787	22,3	12	6	653	827	5	0,17	4	5,9	4
	725	839	22,3	12	7,5	658	892	6	0,21	3,2	4,8	3,2
	697	823	22,3	12	7,5	658	892	6	0,28	2,4	3,6	2,5
	755	918	22,3	12	7,5	662	998	6	0,30	2,3	3,4	2,2
	738	885	22,3	12	7,5	662	998	6	0,37	1,8	2,7	1,8



Spherical roller bearings

d 670 – 850 mm

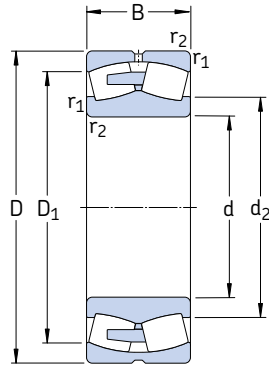

Cylindrical bore

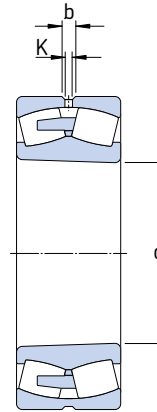

Tapered bore

Principal dimensions			Basic load ratings		Fatigue load limit P_u	Speed ratings		Mass	Designations	
d	D	B	dynamic C	static C_0		Refer- ence speed	Limiting speed		Bearing with cylindrical bore	tapered bore
mm			kN		kN	r/min		kg	–	
670	820	112	2 250	6 400	440	360	700	130	238/670 CAMA/W20	238/670 CAKMA/W20
	820	150	3 110	9 500	655	360	700	172	248/670 CAMA/W20	–
	900	170	5 000	10 800	695	360	670	315	239/670 CA/W33	239/670 CAK/W33
	980	230	7 650	14 600	915	340	600	600	230/670 CA/W33	230/670 CAK/W33
	980	308	10 000	20 400	1 320	300	500	790	240/670 ECA/W33	240/670 ECAK30/W33
	1 090	336	10 900	22 400	1 370	240	500	1 250	231/670 CA/W33	231/670 CAK/W33
	1 090	412	13 800	29 000	1 760	200	400	1 600	241/670 ECA/W33	241/670 ECAK30/W33
1 220	438	15 400	30 500	1 700	220	360	2 270	232/670 CA/W33	232/670 CAK/W33	
710	870	118	2 580	7 500	500	340	670	153	238/710 CAMA/W20	–
	950	180	5 600	12 000	765	340	600	365	239/710 CA/W33	239/710 CAK/W33
	950	243	6 800	15 600	930	300	500	495	249/710 CA/W33	249/710 CAK30/W33
	1 030	236	8 300	16 300	1 000	320	560	670	230/710 CA/W33	230/710 CAK/W33
	1 030	315	10 400	22 000	1 370	280	450	895	240/710 ECA/W33	240/710 ECAK30/W33
	1 150	345	12 200	26 000	1 530	240	450	1 450	231/710 CA/W33	231/710 CAK/W33
	1 150	438	15 200	32 500	1 900	190	380	1 900	241/710 ECA/W33	241/710 ECAK30/W33
1 280	450	17 600	34 500	2 000	200	320	2 610	232/710 CA/W33	232/710 CAK/W33	
750	920	128	2 930	8 500	550	320	600	180	238/750 CAMA/W20	238/750 CAKMA/W20
	1 000	185	6 000	13 200	815	320	560	420	239/750 CA/W33	239/750 CAK/W33
	1 000	250	7 650	18 000	1 100	280	480	560	249/750 CA/W33	249/750 CAK30/W33
	1 090	250	9 650	18 600	1 100	300	530	795	230/750 CA/W33	230/750 CAK/W33
	1 090	335	11 400	24 000	1 400	260	430	1 065	240/750 ECA/W33	240/750 ECAK30/W33
	1 220	365	13 800	29 000	1 660	220	430	1 700	231/750 CA/W33	231/750 CAK/W33
	1 220	475	17 300	37 500	2 160	180	360	2 100	241/750 ECA/W33	241/750 ECAK30/W33
1 360	475	18 700	36 500	2 120	190	300	3 050	232/750 CAF/W33	232/750 CAKF/W33	
800	980	180	4 140	12 900	830	300	560	300	248/800 CAMA/W20	248/800 CAK30MA/W20
	1 060	195	6 400	14 300	880	300	530	470	239/800 CA/W33	239/800 CAK/W33
	1 060	258	8 000	19 300	1 060	260	430	640	249/800 CA/W33	249/800 CAK30/W33
	1 150	258	10 000	20 000	1 160	280	480	895	230/800 CA/W33	230/800 CAK/W33
	1 150	345	12 500	27 500	1 730	240	400	1 200	240/800 ECA/W33	240/800 ECAK30/W33
	1 280	375	14 800	31 500	1 800	200	400	1 920	231/800 CA/W33	231/800 CAK/W33
	1 280	475	18 400	40 500	2 320	170	320	2 300	241/800 ECA/W33	241/800 ECAK30/W33
850	1 030	136	3 340	10 000	640	260	530	240	238/850 CAMA/W20	238/850 CAKMA/W20
	1 120	200	6 950	15 600	930	280	480	560	239/850 CA/W33	239/850 CAK/W33
	1 120	272	9 300	22 800	1 370	240	400	740	249/850 CA/W33	249/850 CAK30/W33
	1 220	272	9 370	21 600	1 270	240	450	1 050	230/850 CA/W33	230/850 CAK/W33
	1 220	365	12 700	31 500	1 900	200	360	1 410	240/850 ECA/W33	240/850 ECAK30/W33
	1 360	400	16 100	34 500	2 000	180	360	2 200	231/850 CA/W33	231/850 CAK/W33
	1 360	500	20 200	45 000	2 550	150	300	2 710	241/850 ECAF/W33	241/850 ECAK30F/W33

The designations of SKF Explorer bearings are printed in blue

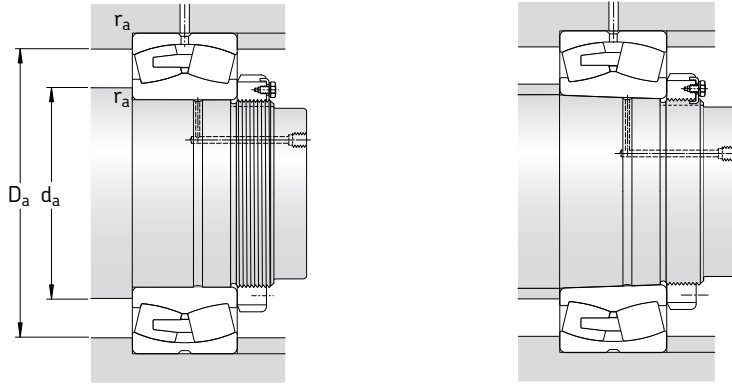

Dimensions

Abutment and fillet dimensions

Calculation factors

d	d ₂	D ₁	b	K	r _{1,2} min	d _a max	D _a max	r _a max	e	Y ₁	Y ₂	Y ₀	
mm						mm			–				
670	720	778	–	9	4	685	805	3	0,11	6,1	9,1	6,3	
	718	772	–	9	4	685	805	3	0,16	4,2	6,3	4	
	749	835	22,3	12	6	693	877	5	0,17	4	5,9	4	
	770	892	22,3	12	7,5	698	952	6	0,21	3,2	4,8	3,2	
	756	866	22,3	12	7,5	698	952	6	0,28	2,4	3,6	2,5	
	802	959	22,3	12	7,5	702	1 058	6	0,30	2,3	3,4	2,2	
	782	942	22,3	12	7,5	702	1 058	6	0,37	1,8	2,7	1,8	
	830	1 028	22,3	12	12	718	1 172	10	0,35	1,9	2,9	1,8	
	710	762	826	–	12	4	725	855	3	0,11	6,1	9,1	6,3
		788	882	22,3	12	6	733	927	5	0,17	4	5,9	4
792		868	22,3	12	6	733	927	5	0,22	3	4,6	2,8	
814		941	22,3	12	7,5	738	1 002	6	0,21	3,2	4,8	3,2	
807		918	22,3	12	7,5	738	1 002	6	0,27	2,5	3,7	2,5	
850		1 017	22,3	12	9,5	750	1 110	8	0,28	2,4	3,6	2,5	
826		989	22,3	12	9,5	750	1 110	8	0,37	1,8	2,7	1,8	
875		1 097	22,3	12	12	758	1 232	10	0,35	1,9	2,9	1,8	
750		807	873	–	12	5	768	902	4	0,11	6,1	9,1	6,3
		832	930	22,3	12	6	773	977	5	0,16	4,2	6,3	4
	830	916	22,3	12	6	773	977	5	0,22	3	4,6	2,8	
	860	998	22,3	12	7,5	778	1 062	6	0,21	3,2	4,8	3,2	
	853	970	22,3	12	7,5	778	1 062	6	0,28	2,4	3,6	2,5	
	900	1 080	22,3	12	9,5	790	1 180	8	0,28	2,4	3,6	2,5	
	875	1 050	22,3	12	9,5	790	1 180	8	0,37	1,8	2,7	1,8	
	938	1 163	22,3	12	15	808	1 302	12	0,35	1,9	2,9	1,8	
	800	862	921	–	12	5	818	962	4	0,15	4,5	6,7	4,5
		885	986	22,3	12	6	823	1 037	5	0,16	4,2	6,3	4
883		973	22,3	12	6	823	1 037	5	0,21	3,2	4,8	3,2	
915		1 053	22,3	12	7,5	828	1 122	6	0,20	3,4	5	3,2	
908		1 028	22,3	12	7,5	828	1 122	6	0,27	2,5	3,7	2,5	
950		1 141	22,3	12	9,5	840	1 240	8	0,28	2,4	3,6	2,5	
930		1 111	22,3	12	9,5	840	1 240	8	0,35	1,9	2,9	1,8	
850		910	981	–	12	5	868	1 012	4	0,11	6,1	9,1	6,3
		940	1 046	22,3	12	6	873	1 097	5	0,16	4,2	6,3	4
		940	1 029	22,3	12	6	873	1 097	5	0,22	3	4,6	2,8
	969	1 117	22,3	12	7,5	878	1 192	6	0,20	3,4	5	3,2	
	954	1 088	22,3	12	7,5	878	1 192	6	0,27	2,5	3,7	2,5	
	1 010	1 205	22,3	12	12	898	1 312	10	0,28	2,4	3,6	2,5	
	988	1 182	22,3	12	12	898	1 312	10	0,35	1,9	2,9	1,8	



Spherical roller bearings
d 900 – 1 800 mm

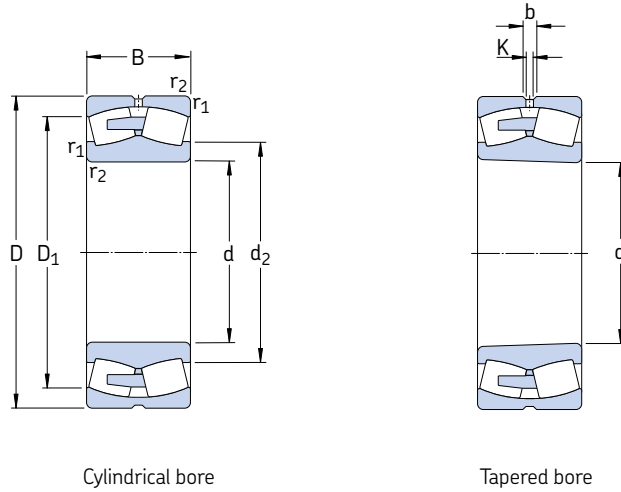

Cylindrical bore

Tapered bore

Principal dimensions			Basic load ratings		Fatigue load limit P_u	Speed ratings		Mass	Designations	
d	D	B	dynamic C	static C_0		Refer- ence speed	Limiting speed		Bearing with cylindrical bore	tapered bore
mm			kN		kN	r/min		kg	–	
900	1 090	190	4 660	15 300	950	240	480	370	248/900 CAMA/W20	248/900 CAK30MA/W20
	1 180	206	7 500	17 000	1 020	260	450	605	239/900 CA/W33	239/900 CAK/W33
	1 280	280	10 100	23 200	1 340	220	400	1 200	230/900 CA/W33	230/900 CAK/W33
	1 280	375	13 600	34 500	2 040	190	340	1 570	240/900 ECA/W33	240/900 ECAK30/W33
	1 420	515	21 400	49 000	2 700	140	280	3 350	241/900 ECAF/W33	241/900 ECAK30F/W33
950	1 250	224	7 250	19 600	1 120	220	430	755	239/950 CA/W33	239/950 CAK/W33
	1 250	300	9 200	26 000	1 500	180	340	1 015	249/950 CA/W33	249/950 CAK30/W33
	1 360	300	12 000	28 500	1 600	200	380	1 450	230/950 CA/W33	230/950 CAK/W33
	1 360	412	14 800	39 000	2 320	170	300	1 990	240/950 CAF/W33	240/950 CAK30F/W33
	1 500	545	23 900	55 000	3 000	130	260	3 535	241/950 ECAF/W33	241/950 ECAK30F/W33
1 000	1 220	165	4 660	14 300	865	220	400	410	238/1000 CAMA/W20	238/1000 CAKMA/W20
	1 320	315	10 400	29 000	1 500	170	320	1 200	249/1000 CA/W33	249/1000 CAK30/W33
	1 420	308	12 700	30 500	1 700	180	360	1 600	230/1000 CAF/W33	230/1000 CAKF/W33
	1 420	412	15 400	40 500	2 240	160	280	2 140	240/1000 CAF/W33	240/1000 CAK30F/W33
	1 580	462	21 400	48 000	2 550	140	280	3 500	231/1000 CAF/W33	231/1000 CAKF/W33
1 580	580	26 700	62 000	3 350	120	240	4 300	241/1000 ECAF/W33	241/1000 ECAK30F/W33	
1 060	1 280	165	4 770	15 000	800	200	380	435	238/1060 CAMA/W20	238/1060 CAKMA/W20
	1 280	218	6 100	20 000	1 200	200	380	570	248/1060 CAMA/W20	248/1060 CAK30MA/W20
	1 400	250	9 550	26 000	1 460	180	360	1 100	239/1060 CAF/W33	239/1060 CAKF/W33
	1 400	335	11 500	32 500	1 860	160	280	1 400	249/1060 CAF/W33	249/1060 CAK30F/W33
	1 500	325	13 800	34 000	1 830	170	320	2 250	230/1060 CAF/W33	230/1060 CAKF/W33
1 500	438	17 300	45 500	2 500	150	260	2 515	240/1060 CAF/W33	240/1060 CAK30F/W33	
1 120	1 360	243	7 250	24 000	1 400	180	340	735	248/1120 CAFA/W20	248/1120 CAK30FA/W20
	1 460	335	11 700	34 500	1 830	140	260	1 500	249/1120 CAF/W33	249/1120 CAK30F/W33
	1 580	462	18 700	50 000	2 850	130	240	2 925	240/1120 CAF/W33	240/1120 CAK30F/W33
1 180	1 420	180	5 870	18 600	1 080	170	320	575	238/1180 CAFA/W20	238/1180 CAKFA/W20
	1 420	243	7 710	27 000	1 560	170	320	770	248/1180 CAFA/W20	248/1180 CAK30FA/W20
	1 540	272	11 100	31 000	1 660	150	300	1 400	239/1180 CAF/W33	239/1180 CAKF/W33
	1 540	355	13 600	40 500	2 160	130	240	1 800	249/1180 CAF/W33	249/1180 CAK30F/W33
1 250	1 750	375	17 900	45 000	2 400	130	240	2 840	230/1250 CAF/W33	230/1250 CAKF/W33
1 320	1 600	280	9 780	33 500	1 860	140	260	1 160	248/1320 CAFA/W20	248/1320 CAK30FA/W20
	1 720	400	16 100	49 000	2 550	110	200	2 500	249/1320 CAF/W33	249/1320 CAK30F/W33
1 500	1 820	315	12 700	45 000	2 400	110	200	1 710	248/1500 CAFA/W20	248/1500 CAK30FA/W20
1 800	2 180	375	17 600	63 000	3 050	75	130	2 900	248/1800 CAFA/W20	248/1800 CAK30FA/W20

The designations of SKF Explorer bearings are printed in blue

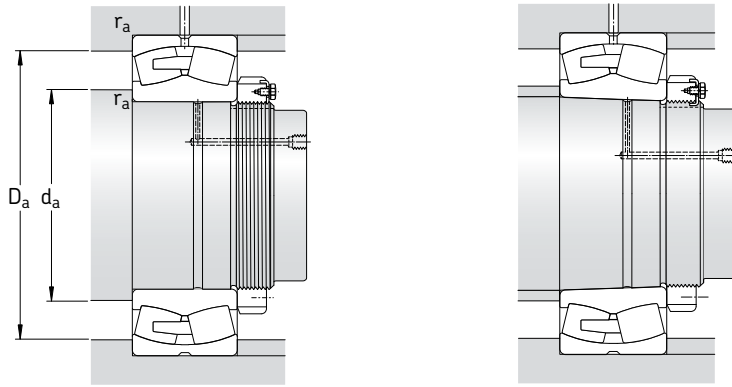

Dimensions

Abutment and fillet dimensions

Calculation factors

d	d ₂	D ₁	b	K	r _{1,2} min	d _a max	D _a max	r _a max	e	Y ₁	Y ₂	Y ₀
mm						mm			–			
900	966	1 029	–	12	5	918	1 072	4	0,14	4,8	7,2	4,5
	989	1 101	22,3	12	6	923	1 157	5	0,15	4,5	6,7	4,5
	1 023	1 176	22,3	12	7,5	928	1 252	6	0,20	3,4	5	3,2
	1 012	1 149	22,3	12	7,5	928	1 252	6	0,26	2,6	3,9	2,5
	1 043	1 235	22,3	12	12	948	1 372	10	0,35	1,9	2,9	1,8
950	1 049	1 164	22,3	12	7,5	978	1 222	6	0,15	4,5	6,7	4,5
	1 051	1 150	22,3	12	7,5	978	1 222	6	0,21	3,2	4,8	3,2
	1 083	1 246	22,3	12	7,5	978	1 332	6	0,20	3,4	5	3,2
	1 074	1 214	22,3	12	7,5	978	1 332	6	0,27	2,5	3,7	2,5
	1 102	1 305	22,3	12	12	998	1 452	10	0,35	1,9	2,9	1,8
1 000	1 077	1 161	–	12	6	1 023	1 197	5	0,12	5,6	8,4	5,6
	1 106	1 212	22,3	12	7,5	1 028	1 292	6	0,21	3,2	4,8	3,2
	1 139	1 305	22,3	12	7,5	1 028	1 392	6	0,19	3,6	5,3	3,6
	1 133	1 278	22,3	12	7,5	1 028	1 392	6	0,26	2,6	3,9	2,5
	1 182	1 403	22,3	12	12	1 048	1 532	10	0,28	2,4	3,6	2,5
1 159	1 373	22,3	12	12	1 048	1 532	10	0,35	1,9	2,9	1,8	
1 060	1 135	1 219	–	12	6	1 083	1 257	5	0,11	6,1	9,1	6,3
	1 135	1 210	–	12	6	1 083	1 257	5	0,14	4,8	7,2	4,5
	1 171	1 305	22,3	12	7,5	1 088	1 372	6	0,16	4,2	6,3	4
	1 165	1 286	22,3	12	7,5	1 088	1 372	6	0,21	3,2	4,8	3,2
	1 202	1 378	22,3	12	9,5	1 094	1 466	8	0,19	3,6	5,3	3,6
1 196	1 349	22,3	12	9,5	1 094	1 466	8	0,26	2,6	3,9	2,5	
1 120	1 202	1 282	–	12	6	1 143	1 337	5	0,15	4,5	6,7	4,5
	1 230	1 350	22,3	12	7,5	1 148	1 432	6	0,20	3,4	5	3,2
	1 266	1 423	22,3	12	9,5	1 154	1 546	8	0,26	2,6	3,9	2,5
1 180	1 261	1 355	–	12	6	1 203	1 397	5	0,11	6,1	9,1	6,3
	1 268	1 344	–	12	6	1 203	1 397	5	0,14	4,8	7,2	4,5
	1 298	1 439	22,3	12	7,5	1 208	1 512	6	0,16	4,2	6,3	4
	1 303	1 422	22,3	12	7,5	1 208	1 512	6	0,20	3,4	5	3,2
1 250	1 411	1 611	22,3	12	9,5	1 284	1 716	8	0,19	3,6	5,3	3,6
1 320	1 417	1 511	–	12	6	1 343	1 577	5	0,15	4,5	6,7	4,5
	1 445	1 589	22,3	12	7,5	1 348	1 692	6	0,21	3,2	4,8	3,2
1 500	1 612	1 719	–	12	7,5	1 528	1 792	6	0,15	4,5	6,7	4,5
1 800	1 932	2 060	–	12	9,5	1 834	2 146	8	0,15	4,5	6,7	4,5

Sealed spherical roller bearings

d 25 – 120 mm

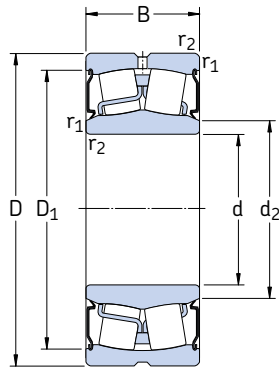

Cylindrical bore

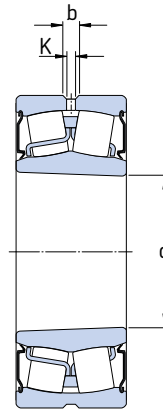

Tapered bore

Principal dimensions			Basic load ratings		Fatigue load limit P_u	Limiting speed	Mass	Designations	
d	D	B	dynamic C	static C_0				Bearing with cylindrical bore	tapered bore
mm			kN		kN	r/min	kg	–	
25	52	23	49	44	4,75	3 600	0,31	BS2-2205-2CS	–
30	62	25	64	60	6,4	2 800	0,34	BS2-2206-2CS	–
35	72	28	86,5	85	9,3	2 400	0,52	BS2-2207-2CS	–
40	80	28	96,5	90	9,8	2 200	0,57	BS2-2208-2CS	BS2-2208-2CSK
	90	38	150	140	15	1 900	1,20	BS2-2308-2CS	–
45	85	28	102	98	10,8	2 000	0,66	BS2-2209-2CS	BS2-2209-2CSK
50	90	28	104	108	11,8	1 900	0,70	BS2-2210-2CS	BS2-2210-2CSK
55	100	31	125	127	13,7	1 700	1,00	BS2-2211-2CS	BS2-2211-2CSK
	120	49	270	280	30	1 400	2,80	BS2-2311-2CS	–
60	110	34	156	166	18,6	1 600	1,30	BS2-2212-2CS	BS2-2212-2CSK
65	100	35	132	173	20,4	1 000	0,95	24013-2CS5/VT143	–
	120	38	193	216	24	1 500	1,60	BS2-2213-2CS	BS2-2213-2CSK
70	125	38	208	228	25,5	1 400	1,80	BS2-2214-2CS	BS2-2214-2CSK
75	115	40	173	232	28,5	950	1,55	24015-2CS2/VT143	–
	130	38	212	240	26,5	1 300	2,10	BS2-2215-2CS	BS2-2215-2CSK
	160	64	440	475	48	950	6,50	BS2-2315-2CS	–
80	140	40	236	270	29	1 200	2,40	BS2-2216-2CS	BS2-2216-2CSK
85	150	44	285	325	34,5	1 100	3,00	BS2-2217-2CS	BS2-2217-2CSK
90	160	48	325	375	39	1 000	3,70	BS2-2218-2CS	BS2-2218-2CSK
100	150	50	285	415	45,5	800	3,15	24020-2CS2/VT143	–
	165	52	365	490	53	850	4,55	23120-2CS2/VT143	–
	180	55	425	490	49	900	5,50	BS2-2220-2CS	BS2-2220-2CSK
	180	60,3	475	600	63	700	6,85	23220-2CS	–
110	170	45	310	440	46,5	900	3,75	23022-2CS	–
	180	56	430	585	61	800	5,55	23122-2CS2/VT143	–
	180	69	520	750	78	630	6,85	24122-2CS2/VT143	–
	200	63	560	640	63	800	7,60	BS2-2222-2CS5/VT143	–
120	180	46	355	510	52	850	4,20	23024-2CS2/VT143	–
	180	60	430	670	68	670	5,45	24024-2CS2/VT143	–
	200	80	655	950	95	560	10,5	24124-2CS2/VT143	–
	215	69	630	765	73,5	750	9,75	BS2-2224-2CS	–

The designations of SKF Explorer bearings are printed in blue

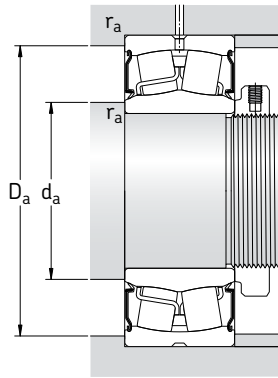

Dimensions						Abutment and fillet dimensions				Calculation factors			
d	d ₂ ≈	D ₁ ≈	b	K	r _{1,2} min	d _a min	d _a max	D _a max	r _a max	e	Y ₁	Y ₂	Y ₀
mm						mm				-			
25	30	44,6	3,7	2	1	30	30	46,4	1	0,35	1,9	2,9	1,8
30	36	55,7	3,7	2	1	35,6	36	56,4	1	0,31	2,2	3,3	2
35	43	63,7	3,7	2	1,1	42	43	65	1	0,31	2,2	3,3	2,2
40	47 47,5	73 81	5,5 5,5	3 3	1,1 1,5	47 47,5	47 47,5	73 81	1 1,5	0,28 0,37	2,4 1,8	3,6 2,7	2,5 1,8
45	53	77,1	5,5	3	1,1	52	53	78	1	0,26	2,6	3,9	2,5
50	58	82,1	5,5	3	1,1	57	58	83	1	0,24	2,8	4,2	2,8
55	64 67	91,9 109	5,5 5,5	3 3	1,5 2	64 66	64 67	91 109	1,5 2	0,24 0,35	2,8 1,9	4,2 2,9	2,8 1,8
60	69	102	5,5	3	1,5	69	69	101	1,5	0,24	2,8	4,2	2,8
65	71,5 76	92,8 111	3,7 5,5	2 3	1,1 1,5	71 74	71,5 76	94 111	1 1,5	0,27 0,24	2,5 2,8	3,7 4,2	2,5 2,8
70	80	115	5,5	3	1,5	79	80	116	1,5	0,23	2,9	4,4	2,8
75	81,5 84 88	105 119 144	5,5 5,5 8,3	3 3 4,5	1,1 1,5 2,1	81 84 87	81,5 84 88	109 121 148	1 1,5 2	0,28 0,22 0,35	2,4 3 1,9	3,6 4,6 2,9	2,5 2,8 1,8
80	91,5	128	5,5	3	2	91	91,5	129	2	0,22	3	4,6	2,8
85	98	138	5,5	3	2	96	98	139	2	0,22	3	4,6	2,8
90	102	148	5,5	3	2	101	102	149	2	0,24	2,8	4,2	2,8
100	108 112 114 114	139 152 162 161	5,5 5,5 8,3 8,3	3 3 4,5 4,5	1,5 2 2,1 2,1	107 111 112 112	108 112 114 114	143 154 168 168	1,5 2 2 2	0,28 0,27 0,24 0,30	2,4 2,5 2,8 2,3	3,6 3,7 4,2 3,4	2,5 2,5 2,8 2,2
110	122 122 121 126	157 166 163 182	8,3 8,3 5,5 8,3	4,5 4,5 3 4,5	2 2 2 2,1	119 121 121 122	122 122 121 126	161 169 169 188	2 2 2 2	0,23 0,27 0,35 0,25	2,9 2,5 1,9 2,7	4,4 3,7 2,9 4	2,8 2,5 1,8 2,5
120	132 130 132 136	172 166 179 193	5,5 5,5 5,5 11,1	3 3 3 6	2 2 2 2,1	129 129 131 132	132 130 132 136	171 171 189 203	2 2 2 2	0,20 0,28 0,37 0,26	3,4 2,4 1,8 2,6	5 3,6 2,7 3,9	3,2 2,5 1,8 2,5

Sealed spherical roller bearings
d 130 – 220 mm

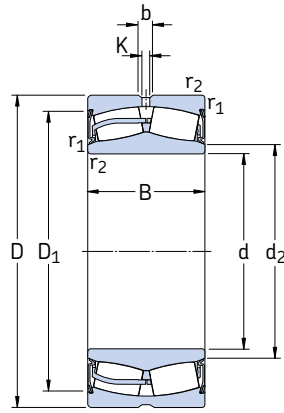

Principal dimensions			Basic load ratings		Fatigue load limit P_u	Limiting speed	Mass	Designation
d	D	B	dynamic C	static C_0				
mm			kN		kN	r/min	kg	–
130	200	52	430	610	62	800	6,00	23026-2CS2/VT143
	200	69	540	815	81,5	600	8,05	24026-2CS2/VT143
	210	80	680	1 000	100	530	11,0	24126-2CS2/VT143
140	210	69	570	900	88	560	8,55	24028-2CS2/VT143
	225	85	765	1 160	112	450	13,5	24128-2CS2/VT143
	250	88	915	1 250	120	530	19,5	23228-2CS5/VT143
150	225	75	655	1 040	100	530	10,5	24030-2CS2/VT143
	250	100	1 020	1 530	146	400	20,0	24130-2CS2/VT143
160	240	80	750	1 200	114	450	13,0	24032-2CS2/VT143
	270	86	980	1 370	129	530	20,5	23132-2CS2/VT143
170	260	90	930	1 460	137	400	17,5	24034-2CS2/VT143
	280	109	1 220	1 860	170	360	27,5	24134-2CS2/VT143
180	280	100	1 080	1 730	156	380	23,0	24036-2CS2/VT143
190	320	128	1 600	2 500	212	340	43,0	24138-2CS2/VT143
200	340	140	1 800	2 800	232	320	53,5	24140-2CS
	360	128	1 860	2 700	228	430	58,0	23240-2CS2/VT143
220	300	60	546	1 080	93	600	12,5	23944-2CS

The designations of SKF Explorer bearings are printed in blue

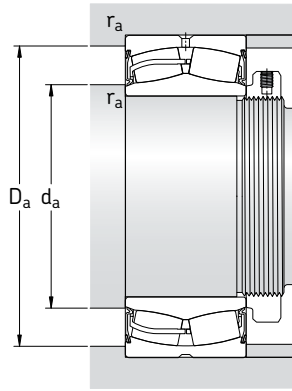

Dimensions					Abutment and fillet dimensions					Calculation factors			
d	d ₂ ≈	D ₁ ≈	b	K	r _{1,2} min	d _a min	d _a max	D _a max	r _a max	e	Y ₁	Y ₂	Y ₀
mm					mm					-			
130	145	186	8,3	4,5	2	139	145	191	2	0,21	3,2	4,8	3,2
	140	183	5,5	3	2	139	140	191	2	0,30	2,3	3,4	2,2
	141	190	5,5	3	2	141	141	199	2	0,33	2	3	2
140	151	195	5,5	3	2	149	151	201	2	0,28	2,4	3,6	2,5
	153	203	8,3	4,5	2,1	152	153	213	2	0,35	1,9	2,9	1,8
	165	212	11,1	6	3	154	165	236	2,5	0,33	2	3	2
150	162	206	5,5	3	2,1	161	162	214	2	0,28	2,4	3,6	2,5
	163	222	8,3	4,5	2,1	162	163	238	2	0,37	1,8	2,7	1,8
160	173	218	8,3	4,5	2,1	171	173	229	2	0,28	2,4	3,6	2,5
	180	244	13,9	7,5	2,1	172	180	258	2	0,28	2,4	3,6	2,5
170	184	235	8,3	4,5	2,1	181	184	249	2	0,30	2,3	3,4	2,2
	185	248	8,3	4,5	2,1	182	185	268	2	0,37	1,8	2,7	1,8
180	194	251	8,3	4,5	2,1	191	194	269	2	0,31	2,2	3,3	2,2
190	210	282	11,1	6	3	204	210	306	2,5	0,40	1,7	2,5	1,6
200	221	294	11,1	6	3	214	221	326	2,5	0,40	1,7	2,5	1,6
	229	320	16,7	9	4	217	229	343	3	0,35	1,9	2,9	1,8
220	238	284	8,3	4,5	2,1	231	238	289	2	0,15	4,5	6,7	4,5

Spherical roller bearings for vibratory applications
d 40 – 170 mm

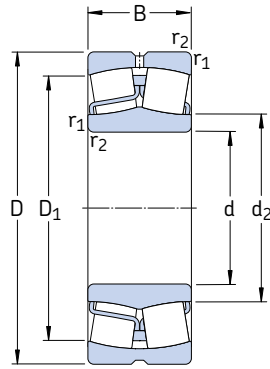

Cylindrical bore

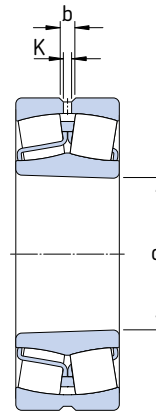

Tapered bored

Principal dimensions			Basic load ratings		Fatigue load limit	Speed ratings		Mass	Designations	
d	D	B	dynamic	static	P_u	Reference speed	Limiting speed		Bearing with cylindrical bore	tapered bore
mm			kN		kN	r/min		kg	–	
40	90	33	150	140	15	6 000	8 000	1,10	22308 E/VA405	–
45	100	36	183	183	19,6	5 300	7 000	1,40	22309 E/VA405	–
50	110	40	220	224	24	4 800	6 300	1,90	22310 E/VA405	–
55	120	43	270	280	30	4 300	5 600	2,45	22311 E/VA405	22311 EK/VA405
60	130	46	310	335	36,5	4 000	5 300	3,10	22312 E/VA405	22312 EK/VA405
65	140	48	340	360	38	3 800	5 000	3,75	22313 E/VA405	22313 EK/VA405
70	150	51	400	430	45	3 400	4 500	4,55	22314 E/VA405	22314 EK/VA405
75	160	55	440	475	48	3 200	4 300	5,55	22315 EJA/VA405	22315 EKJA/VA405
80	170	58	490	540	54	3 000	4 000	6,60	22316 EJA/VA405	22316 EKJA/VA405
85	180	60	550	620	61	2 800	3 800	7,65	22317 EJA/VA405	22317 EKJA/VA405
	180	60	550	620	61	2 800	3 800	7,65	22317 EJA/VA406	–
90	190	64	610	695	67	2 600	3 600	9,05	22318 EJA/VA405	22318 EKJA/VA405
95	200	67	670	765	73,5	2 600	3 400	10,5	22319 EJA/VA405	22319 EKJA/VA405
100	215	73	815	950	88	2 400	3 000	13,5	22320 EJA/VA405	22320 EKJA/VA405
	215	73	815	950	88	2 400	3 000	13,5	22320 EJA/VA406	–
110	240	80	950	1 120	100	2 000	2 800	18,4	22322 EJA/VA405	22322 EKJA/VA405
	240	80	950	1 120	100	2 000	2 800	18,4	22322 EJA/VA406	–
120	260	86	965	1 120	100	2 000	2 600	23,0	22324 CCJA/W33VA405	22324 CCKJA/W33VA405
	260	86	965	1 120	100	2 000	2 600	23,0	22324 CCJA/W33VA406	–
130	280	93	1 120	1 320	114	1 800	2 400	29,0	22326 CCJA/W33VA405	22326 CCKJA/W33VA405
	280	93	1 120	1 320	114	1 800	2 400	29,0	22326 CCJA/W33VA406	–
140	300	102	1 290	1 560	132	1 700	2 200	36,5	22328 CCJA/W33VA405	22328 CCKJA/W33VA405
	300	102	1 290	1 560	132	1 700	2 200	36,5	22328 CCJA/W33VA406	–
150	320	108	1 460	1 760	146	1 600	2 000	43,5	22330 CCJA/W33VA405	22330 CCKJA/W33VA405
	320	108	1 460	1 760	146	1 600	2 000	43,5	22330 CCJA/W33VA406	–
160	340	114	1 600	1 960	160	1 500	1 900	52,0	22332 CCJA/W33VA405	22332 CCKJA/W33VA405
	340	114	1 600	1 960	160	1 500	1 900	52,0	22332 CCJA/W33VA406	–
170	360	120	1 760	2 160	176	1 400	1 800	61,0	22334 CCJA/W33VA405	22334 CCKJA/W33VA405
	360	120	1 760	2 160	176	1 400	1 800	61,0	22334 CCJA/W33VA406	–

The designations of SKF Explorer bearings are printed in blue

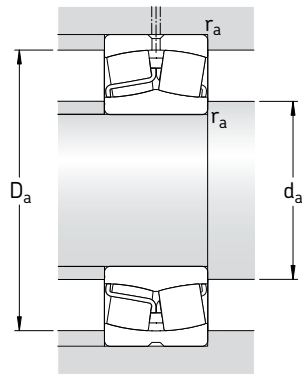

Dimensions				Abutment and fillet dimensions					Calculation factors				Permissible accelerations ¹⁾ for oil lubrication	
d	d ₁	D ₁	b	K	r _{1,2}	d _a	D _a	r _a	e	Y ₁	Y ₂	Y ₀	rotational	linear
mm	-	-	-	min	min	max	max	mm	-	-	-	-	m/s ²	
40	49,7	74,3	5,5	3	1,5	49	81	1,5	0,37	1,8	2,7	1,8	115 g	31 g
45	56,4	83,4	5,5	3	1,5	54	91	1,5	0,37	1,8	2,7	1,8	97 g	29 g
50	62,1	91,9	5,5	3	2	61	99	2	0,37	1,8	2,7	1,8	85 g	28 g
55	70,1	102	5,5	3	2	66	109	2	0,35	1,9	2,9	1,8	78 g	26 g
60	77,9	110	8,3	4,5	2,1	72	118	2	0,35	1,9	2,9	1,8	70 g	25 g
65	81,6	118	8,3	4,5	2,1	77	128	2	0,35	1,9	2,9	1,8	69 g	24 g
70	90,3	128	8,3	4,5	2,1	82	138	2	0,33	2	3	2	61 g	23 g
75	92,8	135	8,3	4,5	2,1	87	148	2	0,35	1,9	2,9	1,8	88 g	23 g
80	98,3	143	8,3	4,5	2,1	92	158	2	0,35	1,9	2,9	1,8	80 g	22 g
85	108	154	8,3	4,5	3	99	166	2,5	0,33	2	3	2	74 g	21 g
	108	154	8,3	4,5	3	99	166	2,5	0,33	2	3	2	74 g	21 g
90	113	161	11,1	6	3	104	176	2,5	0,33	2	3	2	68 g	21 g
95	118	168	11,1	6	3	109	186	2,5	0,33	2	3	2	64 g	20 g
100	130	184	11,1	6	3	114	201	2,5	0,33	2	3	2	56 g	20 g
	130	184	11,1	6	3	114	201	2,5	0,33	2	3	2	56 g	20 g
110	143	204	13,9	7,5	3	124	226	2,5	0,33	2	3	2	53 g	19 g
	143	204	13,9	7,5	3	124	226	2,5	0,33	2	3	2	53 g	19 g
120	152	216	13,9	7,5	3	134	246	2,5	0,35	1,9	2,9	1,8	96 g	21 g
	152	216	13,9	7,5	3	134	246	2,5	0,35	1,9	2,9	1,8	96 g	21 g
130	164	233	16,7	9	4	147	263	3	0,35	1,9	2,9	1,8	87 g	20 g
	164	233	16,7	9	4	147	263	3	0,35	1,9	2,9	1,8	87 g	20 g
140	175	247	16,7	9	4	157	283	3	0,35	1,9	2,9	1,8	78 g	20 g
	175	247	16,7	9	4	157	283	3	0,35	1,9	2,9	1,8	78 g	20 g
150	188	266	16,7	9	4	167	303	3	0,35	1,9	2,9	1,8	72 g	19 g
	188	266	16,7	9	4	167	303	3	0,35	1,9	2,9	1,8	72 g	19 g
160	200	282	16,7	9	4	177	323	3	0,35	1,9	2,9	1,8	69 g	18 g
	200	282	16,7	9	4	177	323	3	0,35	1,9	2,9	1,8	69 g	18 g
170	213	300	16,7	9	4	187	343	3	0,33	2	3	2	65 g	18 g
	213	300	16,7	9	4	187	343	3	0,33	2	3	2	65 g	18 g

¹⁾ For details about permissible accelerations → page 11

Spherical roller bearings for vibratory applications

d 180 – 240 mm

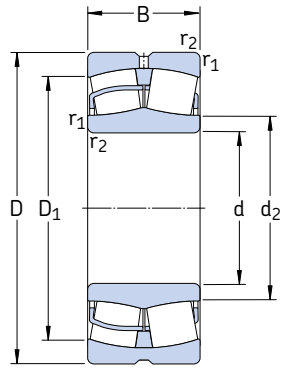

Cylindrical bore

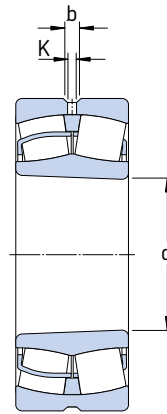

Tapered bored

Principal dimensions			Basic load ratings		Fatigue load limit P_u	Speed ratings		Mass kg	Designations	
d	D	B	dynamic C	static C_0		Reference speed	Limiting speed		Bearing with cylindrical bore	tapered bore
mm			kN		kN	r/min			–	
180	380	126	2 000	2 450	193	1 300	1 700	71,5	22336 CCJA/W33VA405	22336 CCKJA/W33VA405
	380	126	2 000	2 450	193	1 300	1 700	71,5	22336 CCJA/W33VA406	–
190	400	132	2 120	2 650	208	1 200	1 600	82,5	22338 CCJA/W33VA405	22338 CCKJA/W33VA405
	400	132	2 120	2 650	208	1 200	1 600	82,5	22338 CCJA/W33VA406	–
200	420	138	2 320	2 900	224	1 200	1 500	95,0	22340 CCJA/W33VA405	22340 CCKJA/W33VA405
	420	138	2 320	2 900	224	1 200	1 500	95,0	22340 CCJA/W33VA406	–
220	460	145	2 700	3 450	260	1 000	1 400	120	22344 CCJA/W33VA405	22344 CCKJA/W33VA405
240	500	155	3 100	4 000	290	950	1 300	155	22348 CCJA/W33VA405	22348 CCKJA/W33VA405

The designations of SKF Explorer bearings are printed in blue

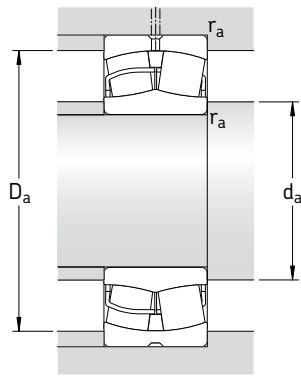

Dimensions				Abutment and fillet dimensions					Calculation factors				Permissible accelerations ¹⁾ for oil lubrication	
d	d ₁	D ₁	b	K	r _{1,2}	d _a	D _a	r _a	e	Y ₁	Y ₂	Y ₀	rotational	linear
mm				mm					-				m/s ²	
180	224	317	22,3	12	4	197	363	3	0,35	1,9	2,9	1,8	59 g	17 g
	224	317	22,3	12	4	197	363	3	0,35	1,9	2,9	1,8	59 g	17 g
190	236	333	22,3	12	5	210	380	4	0,35	1,9	2,9	1,8	57 g	17 g
	236	333	22,3	12	5	210	380	4	0,35	1,9	2,9	1,8	57 g	17 g
200	248	351	22,3	12	5	220	400	4	0,33	2	3	2	55 g	17 g
	248	351	22,3	12	5	220	400	4	0,33	2	3	2	55 g	17 g
220	279	389	22,3	12	5	240	440	4	0,31	2,2	3,3	2,2	49 g	16 g
240	303	423	22,3	12	5	260	480	4	0,31	2,2	3,3	2,2	45 g	15 g

¹⁾ For details about permissible accelerations → page 11

Related SKF products

Special spherical roller bearings

Their robust design and high reliability make SKF spherical roller bearings suitable for the majority of applications. However, extraordinary demands call for bearings with extraordinary features. Therefore, the SKF standard range includes special spherical roller bearings, which are adapted for specific applications:

Sealed bearings for continuous casting applications

These bearings are specially adapted for the heavy loads and high operating temperatures and low speeds present in continuous casting slab guides. They feature seals made of fluoro rubber, and are filled with a very stable high temperature grease, enabling maintenance-free operation in this demanding environment.

Rolling mill bearings

Rolling mill bearings must meet a variety of different demands. For cold tube mills (Pilger mills), for example, the bearings must be able to withstand heavy acceleration forces, whereas for finishing trains or wire mills, they must be able to be mounted and dismounted with ease. SKF offers the appropriate spherical roller bearings for these applications.

SKF ConCentra bearing units

These plummer block type mounted bearing units with SKF Explorer spherical roller bearings in the 222 series on a special adapter sleeve are greased, sealed and ready to install as delivered. With the saw-tooth profile of the inner ring and adapter sleeve, the unit can be mounted and dismounted easily via the incorporated screws without having to use special tools.

See also SKF brochures 4954 "The SKF Copperhead system solution for vibrating screens" and 6103 "SKF ConCentra roller bearing units – true concentric locking, for fast and reliable mounting".

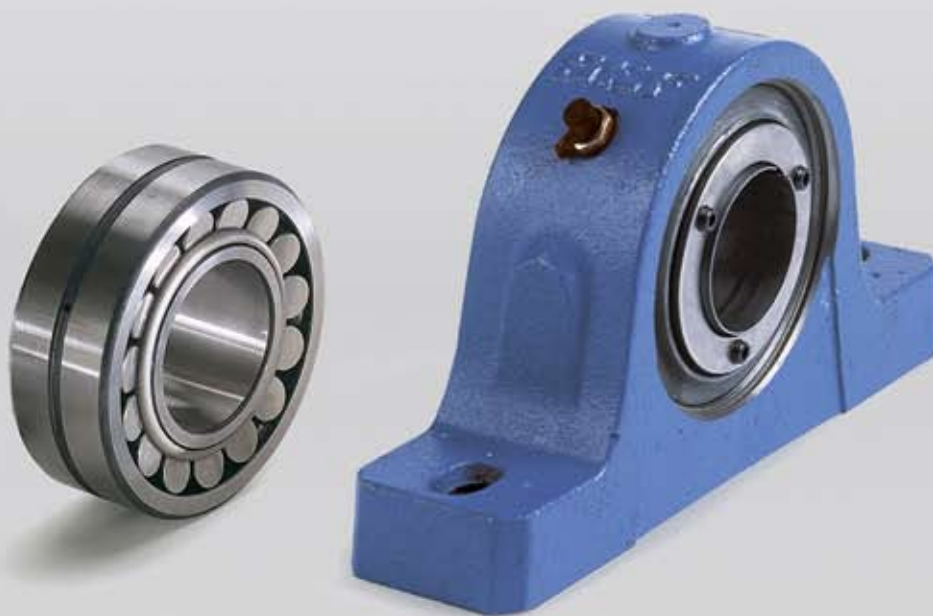

Accessories

Any system is only as strong as its weakest component. Therefore, SKF offers not only a wide range of high quality spherical roller bearings, but also an appropriate range of quality bearing accessories to go with them.

Bearing housings

SKF offers a comprehensive range of high-quality standard and custom housings designed to accommodate the various demands placed on the bearings which they house, e.g. load, accuracy, method of lubrication, type of lubricant, sealing etc.

SKF housings and SKF spherical roller bearings form an economic and interchangeable unit which meets the performance demands of a bearing application.

See also SKF catalogues 6005 and 6006 for detailed information about bearing sleeves and lock nuts respectively and SKF brochures 6112 "SNL plummer block housings solve the housing problems", 6101 "SNL 30 and SNL 31 plummer block housings solve the housing problems" and 6111 "SONL plummer block housings designed for oil lubrication".

Adapter and withdrawal sleeves

Adapter and withdrawal sleeves are used to locate bearings with a tapered bore on smooth or stepped shafts. They facilitate bearing mounting and dismounting and, in many cases, simplify bearing arrangement design. Several series of quality sleeves are included in the SKF product range.

Lock nuts

SKF lock nuts, also referred to as shaft nuts, are available in several designs to axially locate bearings on shaft ends. The most popular are those in the KM, KML and HM series. These nuts have four or eight equally spaced slots in the outside diameter and are locked in position with locking washers or locking clips engaging a groove in the shaft. The nut dimensions are in accordance with ISO 2982-2:1995, as are the dimensions of the series MB and MBL locking washers.

Other lock nuts produced by SKF include lock nuts in the KMT, KMTA, KMK and KMFE series, that do not require a groove in the shaft.



SKF withdrawal and adapter sleeves



SKF lock nuts



Lubricants and lubrication equipment

Spherical roller bearings are required to operate under a variety of load, speed, temperature and environmental conditions. They require the type of high-quality lubricating greases, which SKF provides.

SKF greases have been specially developed for rolling bearings in their typical applications. The SKF range includes fifteen environmentally friendly greases and covers practically all application requirements.

The range is complemented by a selection of lubrication accessories including

- automatic lubricators
- grease guns
- lubricant metering devices
- a wide range of manually and pneumatically operated grease pumps.

See also SKF catalogue MP3000
"SKF Maintenance and Lubrication
Products" or online at
www.mapro.skf.com.

Products for mounting and dismounting

Like all rolling bearings, SKF spherical roller bearings require a high degree of skill when mounting or dismounting, as well as the correct tools and methods.

The comprehensive SKF range of tools and equipment includes everything that is required

- mechanical tools
- heaters
- hydraulic tools and equipment
- pullers and withdrawal tools for all bearing sizes.



SKF Drive-Up Method



SKF lubricants:
the best choice for any bearing

Condition monitoring equipment

The goal of condition monitoring is to maximize uptime, minimize unplanned downtime and reduce maintenance.

To achieve this, SKF recommends monitoring the bearing and other machine components either periodically or continuously. Condition monitoring enables incipient bearing damage to be detected and evaluated, so that bearing replacement can be scheduled for a time when the machine is not in operation, to avoid unplanned stoppages. Applied to all machinery (not just sensitive or problematic machines), condition monitoring optimizes machinery utilization, often exceeding the original equipment projections for service life.

SKF provides a comprehensive range of condition monitoring equipment to measure all important parameters. These include

- temperature
- speed
- noise
- oil condition
- shaft alignment
- vibration
- bearing condition.

Products range from lightweight, handheld devices, to sophisticated continuous monitoring systems for fixed installations that can be integrated into an existing proactive reliability maintenance programme.

One example is the MARLIN® I-Pro data manager, which is a rugged, high performance data collector that enables plant operations personnel to quickly and easily collect, store and analyze overall machine vibration, process and inspection data. The unit enables trending, comparison with previous readings, alarm alerts and more. A “user notes” feature allows an operator to immediately record detailed observations of troublesome machine conditions or questionable measurements.



Recording vibration values using a SKF Microlog Series Data Collector

Taking the temperature



Noise testing



MARLIN® I-Pro data manager



SKF – the knowledge engineering company

From the company that invented the self-aligning ball bearing 100 years ago, SKF has evolved into a knowledge engineering company that is able to draw on five platforms to create unique solutions for its customers. These platforms include bearings, bearing units and seals, of course, but extend to other areas including: lubricants and lubrication systems, critical for long bearing life in many applications; mechatronics that combine mechanical and electronics knowledge into systems for more effective linear motion and sensorized solutions; and a full range of services, from design and logistics support to conditioning monitoring and reliability systems.

Though the scope has broadened, SKF continues to maintain the world's leadership in the design, manufacture and marketing of rolling bearings, as well as complementary products such as radial seals. SKF also holds an increasingly important position in the market for linear motion products, high-precision aerospace bearings, machine tool spindles and plant maintenance services.

The SKF Group is globally certified to ISO 14001, the international standard for environmental management, as well as OHSAS 18001, the health and safety management standard. Individual divisions have been approved for quality certification in accordance with either ISO 9000 or QS 9000.

With some 100 manufacturing sites worldwide and sales companies in 70 countries, SKF is a truly international corporation. In addition, our distributors and dealers in some 15 000 locations around the world, an e-business marketplace and a global distribution system put SKF close to customers for the supply of both products and services. In essence, SKF solutions are available wherever and whenever customers need them. Overall, the SKF brand and the corporation are stronger than ever. As the knowledge engineering company, we stand ready to serve you with world-class product competencies, intellectual resources, and the vision to help you succeed.



© Airbus – photo: e7m company, H. Goussé

Evolving by-wire technology

SKF has a unique expertise in fast-growing by-wire technology, from fly-by-wire, to drive-by-wire, to work-by-wire. SKF pioneered practical fly-by-wire technology and is a close working partner with all aerospace industry leaders. As an example, virtually all aircraft of the Airbus design use SKF by-wire systems for cockpit flight control.

SKF is also a leader in automotive by-wire technology, and has partnered with automotive engineers to develop two concept cars, which employ SKF mechatronics for steering and braking. Further by-wire development has led SKF to produce an all-electric forklift truck, which uses mechatronics rather than hydraulics for all controls.

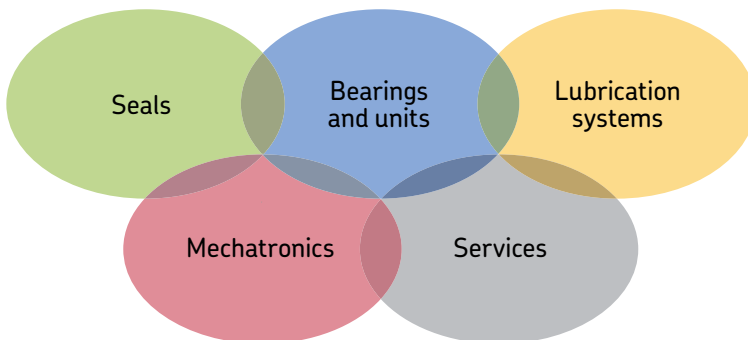



Harnessing wind power

The growing industry of wind-generated electric power provides a source of clean, green electricity. SKF is working closely with global industry leaders to develop efficient and trouble-free turbines, providing a wide range of large, highly specialized bearings and condition monitoring systems to extend equipment life of wind farms located in even the most remote and inhospitable environments.



Working in extreme environments

In frigid winters, especially in northern countries, extreme sub-zero temperatures can cause bearings in railway axleboxes to seize due to lubrication starvation. SKF created a new family of synthetic lubricants formulated to retain their lubrication viscosity even at these extreme temperatures. SKF knowledge enables manufacturers and end user customers to overcome the performance issues resulting from extreme temperatures, whether hot or cold. For example, SKF products are at work in diverse environments such as baking ovens and instant freezing in food processing plants.



Developing a cleaner cleaner

The electric motor and its bearings are the heart of many household appliances. SKF works closely with appliance manufacturers to improve their products' performance, cut costs, reduce weight, and reduce energy consumption. A recent example of this cooperation is a new generation of vacuum cleaners with substantially more suction. SKF knowledge in the area of small bearing technology is also applied to manufacturers of power tools and office equipment.



Maintaining a 350 km/h R&D lab

In addition to SKF's renowned research and development facilities in Europe and the United States, Formula One car racing provides a unique environment for SKF to push the limits of bearing technology. For over 50 years, SKF products, engineering and knowledge have helped make Scuderia Ferrari a formidable force in F1 racing. (The average racing Ferrari utilizes more than 150 SKF components.) Lessons learned here are applied to the products we provide to auto-makers and the aftermarket worldwide.



Delivering Asset Efficiency Optimization

Through SKF Reliability Systems, SKF provides a comprehensive range of asset efficiency products and services, from condition monitoring hardware and software to maintenance strategies, engineering assistance and machine reliability programs. To optimize efficiency and boost productivity, some industrial facilities opt for an Integrated Maintenance Solution, in which SKF delivers all services under one fixed-fee, performance-based contract.



Planning for sustainable growth

By their very nature, bearings make a positive contribution to the natural environment, enabling machinery to operate more efficiently, consume less power, and require less lubrication. By raising the performance bar for our own products, SKF is enabling a new generation of high-efficiency products and equipment. With an eye to the future and the world we will leave to our children, the SKF Group policy on environment, health and safety, as well as the manufacturing techniques, are planned and implemented to help protect and preserve the earth's limited natural resources. We remain committed to sustainable, environmentally responsible growth.



SKF, @ptitude, CARB, MARLIN, Microlog, NoWear, SensorMount and SYSTEM 24 are registered trademarks of the SKF Group.

SKF Explorer and Total Shaft Solutions are trademarks of the SKF Group.

© SKF Group 2006

The contents of this publication are the copyright of the publisher and may not be reproduced (even extracts) unless permission is granted. Every care has been taken to ensure the accuracy of the information contained in this publication but no liability can be accepted for any loss or damage whether direct, indirect or consequential arising out of the use of the information contained herein.

Publication **6100 EN** · September 2006

This publication supersedes publication 5100 E.

Printed in Sweden on environmentally friendly paper.

skf.com