

# Spanners and sockets



# Spanners and sockets

## Interference fits on tapered shafts

Bearings mounted on tapered seatings achieve their interference fit by being driven up the tapered shaft. Care should be taken to ensure the bearing is not driven up too far, as all the internal clearance may be removed and damage to the bearing is possible.

### Incorrect mounting

Bearing driven up too far and all clearance removed; damage possible.

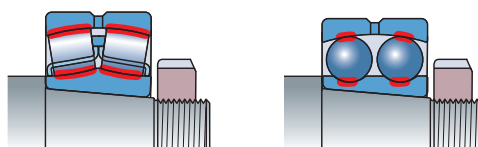

### Correct mounting

Bearing driven up the correct distance and the right clearance is achieved.

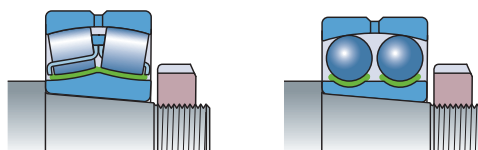

The comprehensive range of SKF spanner and sockets are used to tighten and loosen many types and sizes of bearing lock nuts, for bearings mounted directly on a shaft or on sleeves.



Exact spanner radius reduces the risk of nut damage

## SKF Hook Spanners HN series

- Minimises the risk of shaft and nut damage
- Plastic handle is oil, grease and dirt resistant to provide a better grip
- The plastic handle minimises direct metal to skin contact, reducing the risk of corrosion in the handle area
- Spanner designation is laser-engraved allowing for easy identification and selection
- Available as a set: SKF HN 4-16/SET containing 9 spanners for lock nut sizes 4 up to 16

### Contents SKF HN 4-16/SET

HN 4	HN 8-9	HN 14
HN 5-6	HN 10-11	HN 15
HN 7	HN 12-13	HN 16

### Selection chart – HN series

Designation	Suitable for the following series of SKF lock nuts						
	KM	N	AN	KMK	KMFE	KMT	DIN 1804 (M)
HN 0	0	0		0			M6×0,75, M8×1
HN 1	1	1		1			
HN 2-3	2, 3	2, 3		2, 3		0	M10×1, M12×1,5
HN 4	4	4		4	4	1, 2	M14×1,5, M16×1,5
HN 5-6	5, 6	5, 6		5, 6	5, 6	3, 4, 5	M22×1,5, M24×1,5, M26×1,5
HN 7	7	7		7	7	6, 7	M28×1,5, M30×1,5, M32×1,5, M35×1,5
HN 8-9	8, 9	8, 9		8, 9	8, 9	8	M38×1,5, M40×1,5, M42×1,5
HN 10-11	10, 11	10, 11		10, 11	10, 11	9, 10	M45×1,5, M48×1,5, M50×1,5
HN 12-13	12, 13	12, 13		12, 13	12, 13	11, 12	M52×1,5, M55×1,5, M58×1,5, M60×1,5
HN 14	14		14	14	14		
HN 15	15		15	15	15	13, 14	M62×1,5, M65×1,5, M68×1,5, M70×1,5
HN 16	16		16	16	16	15	
HN 17	17		17	17	17	16	M72×1,5, M75×1,5,
HN 18-20	18, 19, 20		18, 19, 20	18, 19, 20	18, 19, 20	17, 18, 19	M80×2, M85×2, M90×2
HN 21-22	21, 22		21, 22		21, 22	20, 22	M95×2, M100×2

### Technical data – HN series

Designation	Spanner design DIN 1810		Outer diameter lock nut		Designation	Spanner design DIN 1810		Outer diameter lock nut	
	mm		mm	in.		mm		mm	in.
HN 0			16–20	0.6–0.8	HN 12-13	Ø80–Ø90		80–90	3.1–3.5
HN 1	Ø20–Ø22		20–22	0.8–0.9	HN 14			92	3.6
HN 2-3	Ø25–Ø28		25–28	1.0–1.1	HN 15	Ø95–Ø100		95–100	3.7–3.9
HN 4	Ø30–Ø32		30–32	1.2–1.3	HN 16			105	4.1
HN 5-6			38–45	1.5–1.8	HN 17	Ø110–Ø115		110–115	4.3–4.5
HN 7	Ø52–Ø55		52–55	2.0–2.2	HN 18-20	Ø120–Ø130		120–130	4.7–5.1
HN 8-9			58–65	2.3–2.6	HN 21-22	Ø135–Ø145		135–145	5.3–5.7
HN 10-11	Ø68–Ø75		68–75	2.7–3.0					



Four sizes for tightening or loosening up to 24 nut sizes

## SKF Adjustable Hook Spanners HNA series

- One hook spanner covers several nut sizes, making it suitable for use with many applications
- Economic solution: 4 hook spanners cover a wide range of nut sizes
- Laser engraved designation, which represents the range of nut sizes covered by each spanner, allows easy selection of the correct spanner
- Versatile: suitable for a wide selection of lock nuts
- Minimises the risk of shaft and nut damage

### Selection chart and technical data – HNA series

Designation	Outer diameter lock nut		Suitable for the following series of SKF lock nuts						
	mm	in.	KM	KML	N	AN	KMK	KMFE	KMT
HNA 1-4	20–35	0.8–1.4	1–4		2–4		0–4	4	0–2
HNA 5-8	35–60	1.4–2.4	5–8		5–8		5–8	5–8	3–7
HNA 9-13	60–90	2.4–3.5	9–13		9–13		9–13	9–13	8–12
HNA 14-24	90–150	3.5–6.1	14–24	24–26		14–24	14–20	14–24	13–24



Easy and quick bearing mounting and dismounting in SNL housings

## SKF Hook Spanners HN ../SNL series

- Unique design allows the SKF HN ../SNL series to be used inside SKF SNL and SNH bearing housings
- Suitable for tightening and loosening a wide selection of lock nuts, facilitating their use in a wide range of housing and shaft applications
- The large contact area of the spanner around the nut provides excellent grip and force transmission
- Exact fit reduces the risk of shaft, nut and housing damage



### Selection chart and technical data

Designation	Outer diameter lock nut		Suitable for SKF housings	Suitable for the following series of SKF lock nuts								
	mm	in.		SNL	KM	KML	N	AN	KMK	KMFE	KMFE L	KMT*
HN 5/SNL	38	1.50	505, 506–605	5			5		5	5		5
HN 6/SNL	45	1.77	506–605, 507–606	6			6		6	6		6
HN 7/SNL	52	2.05	507–606, 508–607	7			7		7	7		7
HN 8/SNL	58	2.28	508–607, 510–608	8			8		8	8		8
HN 9/SNL	65	2.56	509, 511–609	9			9		9	9		9
HN 10/SNL	70	2.76	510–608, 512–610	10			10		10	10		10
HN 11/SNL	75	2.95	511–609, 513–611	11			11		11	11		11
HN 12/SNL	80	3.15	512–610, 515–612	12			12		12	12		12
HN 13/SNL	85	3.35	513–611, 516–613	13			13		13	13		13
HN 15/SNL	98	3.86	515–612, 518–615	15				15	15	15		15
HN 16/SNL	105	4.13	516–613, 519–616	16				16	16	16		16
HN 17/SNL	110	4.33	517, 520–617	17				17	17	17		17
HN 18/SNL	120	4.72	518–615	18				18	18	18		18
HN 19/SNL	125	4.92	519–616, 522–619	19				19	19	19		19
HN 20/SNL	130	5.12	520–617, 524–620	20			22	20,21	20	20		20
HN 22/SNL	145	5.71	522–619	22	24	24		22		22		22
HN 24/SNL	155	6.10	524–620	24	26	26		24		24		24
HN 26/SNL	165	6.50	526	26	28	28		26		26		26
HN 28/SNL	180	7.09	528	28	30	30						
HN 30/SNL	195	7.68	530	30	32	34	30					32
HN 32/SNL	210	8.27	532	32		36						

\* Not recommended for use in combination with SNL/SNH housing



Easy mounting and dismantling without nut damage

## SKF Axial Lock Nut Sockets TMFS series

- Requires less space around the bearing arrangement than hook spanners
- Inch connections for power tools or torque wrenches
- SKF TMFS fits nuts of series KM, KMK (metric) and KMF
- Special versions are available on request



### Selection chart and technical data

Designation	Suitable for nuts of series			Dimensions						Connection
	KM, KMK	KMFE	DIN 1804 (M)	Outer diameter lock nut		Outer diameter socket		Effective height		
				mm	in.	mm	in.	mm	in.	
TMFS 0	0			18	0.7	22,0	0.9	45	1.8	3/8
TMFS 1	1			22	0.9	28,0	1.1	45	1.8	3/8
TMFS 2	2		M10×1	25	1.0	33,0	1.3	61	2.4	1/2
TMFS 3	3		M12×1,5	28	1.1	36,0	1.4	61	2.4	1/2
TMFS 4	4	4	M16×1,5	32	1.3	38,0	1.5	58	2.3	1/2
TMFS 5	5	5		38	1.5	46,0	1.8	58	2.3	1/2
TMFS 6	6	6	M26×1,5	45	1.8	53,0	2.1	58	2.3	1/2
TMFS 7	7	7	M32×1,5	52	2.0	60,0	2.4	58	2.3	1/2
TMFS 8	8	8	M38×1,5	58	2.3	68,0	2.7	58	2.3	1/2
TMFS 9	9	9		65	2.6	73,5	2.9	63	2.5	3/4
TMFS 10	10	10		70	2.8	78,5	3.1	63	2.5	3/4
TMFS 11	11	11	M48×1,5, M50×1,5	75	3.0	83,5	3.3	63	2.5	3/4
TMFS 12	12	12	M52×1,5, M55×1,5	80	3.1	88,5	3.5	63	2.5	3/4
TMFS 13	13	13		85	3.3	94,0	3.7	63	2.5	3/4
TMFS 14	14	14		92	3.6	103,0	4.1	80	3.2	1
TMFS 15	15	15		98	3.9	109,0	4.3	80	3.2	1
TMFS 16	16	16		105	4.1	116,0	4.6	80	3.2	1
TMFS 17	17	17	M72×1,5, M75×1,5	110	4.3	121,0	4.8	80	3.2	1
TMFS 18	18	18		120	4.7	131,0	5.2	80	3.2	1
TMFS 19	19	19	M85×2	125	4.9	137,0	5.5	80	3.2	1
TMFS 20	20	20	M90×2	130	5.1	143,0	5.7	80	3.2	1



High impact forces without nut damage

## SKF Impact Spanners TMFN series

- Helps avoid shaft and nut damage
- Safe and user friendly
- Impact applied effectively to the nut
- Suitable for a wide selection of lock nuts
- Special wide impact face
- To be used in combination with a hammer

### Selection chart

Designation	Suitable for adapter sleeves		Suitable for nuts of series						
	H 23, H 31, H 32	H 30, H 39	KM	KML	HMT	HM	KMFE	KMT	DIN 1804 (M)
TMFN 23-30	24-30	26-32	23-30	26-32	-	-	23-28 26L-28L	24-30	M105x2, M105x2, M110x2, M115x2, M120x2, M125x2, M130x3, M140x3, M150x3, M160x3
TMFN 30-40	30-40	34-40	32-38	34-40	-	-	30-40	32-40	M170x3, M180x3, M190x3, M200x3
TMFN 40-52	40-48	44-52	40	-	42T-50T	3044-3052	-	40, 44, 48	-
TMFN 52-64	52-64	56-68	-	-	52T-56T	3056-3068	-	-	-
TMFN 64-80	64-80	68-88	-	-	-	3168-3088	-	-	-
TMFN 80-500	80-500	88-530	-	-	-	3184-30/500	-	-	-
TMFN 500-600	500-600	530-630	-	-	-	31/500-30/630	-	-	-
TMFN 600-750	600-750	670-800	-	-	-	31/600-31/800	-	-	-

### Technical data

Designation	Lock nut outer diameter	
	mm	in.
TMFN 23-30	150-220	5.9-8.7
TMFN 30-40	195-270	7.7-10.6
TMFN 40-52	250-320	9.8-12.6
TMFN 52-64	330-400	12.6-15.7
TMFN 64-80	420-520	15.7-20.5
TMFN 80-500	540-620	21.3-24.8
TMFN 500-600	630-730	24.8-29.5
TMFN 600-750	750-950	29.5-37.4

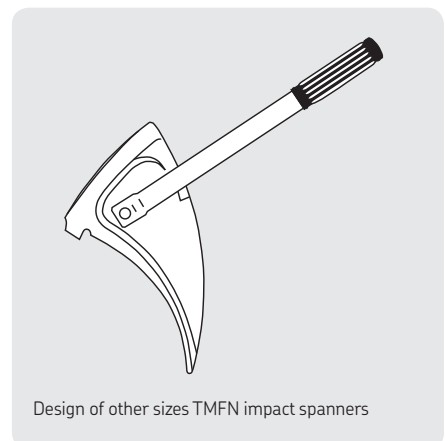



For achieving the correct radial clearance

## SKF Bearing Lock Nut Spanner TMHN 7 series

The SKF TMHN 7 set of lock nut spanners is especially designed for mounting self-aligning ball bearings as well as small spherical roller and CARB toroidal roller bearings on tapered seatings. Using the SKF TMHN 7, minimises the risk of over-tightening of the lock nut, which can remove the bearing's radial clearance resulting in bearing damage.

- 7 different-sized spanners to fit nut sizes 5 to 11
- Each spanner is equipped with a protractor and is clearly marked with the correct tightening angle for mounting SKF Self-aligning ball bearings
- 4 grip points on each spanner provide a better and safer grip on the nut
- Reduced risk of damaging bearing by over-tightening
- Suitable for use with lock nuts of the KM series either on shaft or in SNL housings

### TMHN 7 is suitable for use with:

#### Bearing designation

1205 EK-1211 EK

1306 EK-1311 EK

2205 EK-2211 EK

2306 K

2307 EK-2309 EK

2310 K-2311 K

### Technical data

#### Designation

TMHN 7

#### Dimensions of case (w × d × h)

340 × 250 × 80 mm  
(13.4 × 9.8 × 3.1 in.)

#### Weight

2,2 kg (4.7 lb)

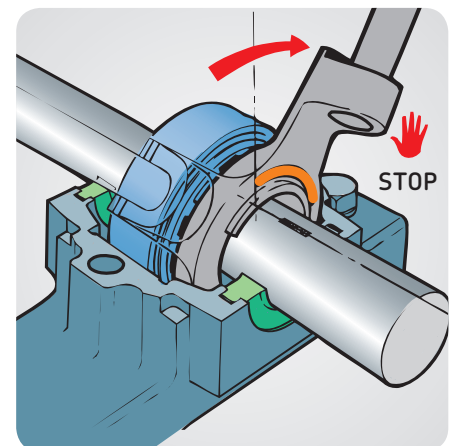
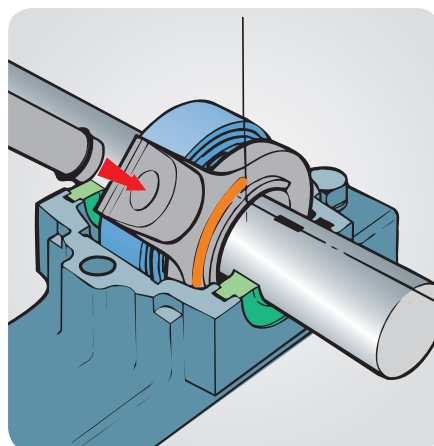
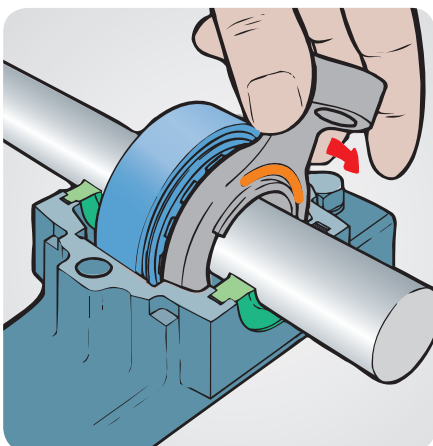

® SKF is a registered trademark of the SKF Group.

© SKF Group 2013

The contents of this publication are the copyright of the publisher and may not be reproduced (even extracts) unless prior written permission is granted. Every care has been taken to ensure the accuracy of the information contained in this publication but no liability can be accepted for any loss or damage whether direct, indirect or consequential arising out of the use of the information contained herein.

PUB MP/P8 13074 EN · December 2013

