



SKF Lubrication Products and Systems

The industry's most complete resource for knowledge-engineered lubrication solutions

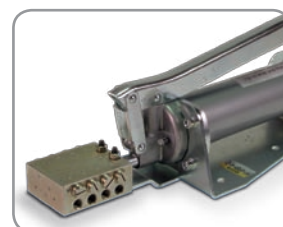

Table of contents

4 Lubricants



Manual lubrication 28

36 Automatic lubricators



51 Centralized lubrication systems



Accessories

88



Thousands One

With more than 100 years of rotating machinery expertise, SKF knows bearings. And since much of that expertise involves the science of tribology – the combination of friction, wear and lubrication sciences – SKF knows lubrication, too.

Lubricants

The extensive line of SKF lubricants includes a range of greases and oils, and reflects decades of research and development across many industries. The comprehensive guide featured in this catalog makes choosing the right lubricant easy – select the appropriate grease or oil according to the temperature, speed and load ranges of a particular application.

Manual lubrication

Comprised of grease guns, packers, pumps and meters, SKF manual lubrication products give maintenance professionals many user-friendly tools to keep bearings supplied with precise amounts of contaminant-free grease.



of lubrication needs source for lubrication expertise

For example, as much as 36% of premature bearing failures are caused by lubrication problems – too much, too little, the wrong type, or contaminated lubricant. Preventing such lubrication – related failures, as well as ensuring optimal bearing

performance, means delivering the right lubricant, in the right amount, at the right time, with the right lubrication system, at the right lubrication point. Today, SKF delivers a complete line of lubrication solutions to do exactly that. We can now offer a complete

range, from specialized lubricants and manual lubricators to the most sophisticated automatic and centralized lubrication systems on the market.

Automatic lubricators

From single-point to multi-point units, SKF automatic lubricators provide reliable time- and labor-saving alternatives to manual lubrication. Around-the-clock SKF solutions such as SKF SYSTEM 24 and SKF MultiPoint provide precise, contaminant-free grease, with minimal risk of over- or under-lubricating.

Centralized lubrication systems

SKF Centralized Lubrication Systems feed lubricant from a central source to the connected points on a machine or machining system. Friction and wear is minimized, often unsafe manual lubrication is eliminated and lubricant amount is optimized. SKF centralized lubrication systems are virtually maintenance-free. Maintenance is limited to refilling the lubrication reservoir and periodic visual inspection of the connected lubrication points.

Accessories

SKF lubrication accessories include a broad range of products designed to make lubrication safer, more efficient, and more convenient for operators. Disposable gloves improve worker safety, while Oil Safe dispensing and storage drums and lids protect against contamination. Small, portable daily lubrication kits and hand-held grease pumps make maintenance tasks easier.





Lubricants

SKF bearing greases:
the perfect solution for every application.....6
Bearing grease selection charts7
Relubrication intervals..... 10
Lubrication methods..... 10
SKF bearing greases and their applications..... 11
Glossary of lubrication terms 16
Chain oil range 20
Dry Film Lubricant..... 21
Anti-fretting Agent..... 22
Anti-corrosive Agent..... 22
Technical data..... 23



SKF bearing greases: the perfect solution for every application

Even the very best bearing can only show optimum performance when it is lubricated correctly.

Here, it is extremely important to choose the right bearing grease and to apply the most suitable lubrication intervals and methods. This realization has prompted SKF to look intensively into the subject of lubrication. SKF engineers consider grease to be a fundamental component of the bearing arrangement and thus, as important as the bearing, housing and sealing.

SKF's vast experience in the development of rolling bearings forms the basis for the development of a special range of lubricants, the superior quality of which is obtained through continuous testing and studies.

The strict standards and testing parameters developed and applied at the SKF Engineering and Research Center have become internationally recognized benchmarks for bearing greases. The comprehensive range of SKF bearing greases is the result of many decades of research and development. Each individual lubricant is precisely adjusted to the respective field of application.

SKF sets the standard

Tangible performance parameters mean more to SKF than the chemical composition of the lubricant. The chemical composition is not the only factor in determining the quality of a particular grease, since modern lubricants are extremely complex. SKF has set the standards for developing special testing parameters.

Bearing grease selection

Selecting the right bearing grease for a certain application is essential for achieving the maximum service life of a bearing. Selection criteria for correct lubrication include bearing type and size, temperatures, speeds and loads, as well as the desired service life and relubrication intervals. To select the proper SKF grease, refer to the reference table for temperature, speed and load ranges. SKF greases suitable for use in an application based on the combination of temperature, speed and load ranges are shown in the charts on pages 7 to 9. More information about all SKF greases can be found on pages 11 to 15 and in the technical information section on pages 24 to 27.



Bearing grease selection

Generally use if: Speed = M, Temperature = M and Load = M

Unless:

Expected bearing temperature continuously > 100 °C / 212 °F

Expected bearing temperature continuously > 150 °C / 302 °F, demands for radiation resistance

Low ambient -50 °C / -58 °F, expected bearing temperature < 50 °C / 122 °F

Shock loads, heavy loads, frequent start-up / shut-down

Food processing industry

"Green" biodegradable, demands for low toxicity

LGMT 2

General purpose

LGHP 2

High temperature

LGET 2

Extremely high temperature

LGLT 2

Low temperature

LGEP 2

High load

LGFP 2

Food processing

LGGB 2

"Green" biodegradable

Note: - For areas with relatively high ambient temperatures, use LGMT 3 instead of LGMT 2
- For special operating conditions, refer to the SKF bearing grease selection chart

Bearing operating parameters

Temperature

L = Low

M = Medium

H = High

EH = Extremely high

<50 °C / 122 °F

50 to 100 °C / 122 to 230 °F

>100 °C / 212 °F

> 150 °C / 302 °F

Speed for ball bearings

EH = Extremely High

VH = Very High

H = High

M = Medium

L = Low

n.dm over 700 000

n.dm up to 700 000

n.dm up to 500 000

n.dm up to 300 000

n.dm below 100 000

Speed for roller bearings

H = High

M = Medium

L = Low

VL = Very Low

SRB/TRB/CARB

n.dm over 210 000

n.dm up to 210 000

n.dm up to 75 000

n.dm below 30 000

Speed for roller bearings

H = High

M = Medium

L = Low

VL = Very Low

CRB

n.dm over 270 000

n.dm up to 270 000

n.dm up to 75 000

n.dm below 30 000

Load

VH = Very high

H = High

M = Medium

L = Low

C/P < 2

C/P ~ 4

C/P ~ 8

C/P 15



SKF bearing grease selection chart

Bearing working conditions	Temp	Speed	Load	Vertical shaft	Fast outer ring rotation	Oscillating movements	Severe vibrations	Shock load or frequent start-up	Low noise	Low friction
LGMT 2	M	M	L to M	○	—	—	+	—	—	○
LGMT 3	M	M	L to M	+	○	—	+	—	—	○
LGEP 2	M	L to M	H	○	—	○	+	+	—	—
LGFP 2	M	M	L to M	○	—	—	—	—	—	○
LGEM 2	M	VL	H to VH	○	—	+	+	+	—	—
LGEV 2	M	VL	H to VH	○	—	+	+	+	—	—
LGLT 2	L to M	M to EH	L	○	—	—	—	○	+	+
LGGB 2	L to M	L to M	M to H	○	—	+	+	+	—	○
LGWM 1	L to M	L to M	H	—	—	+	—	+	—	—
LGWM 2	L to M	L to M	M to H	○	○	+	+	+	—	—
LGWA 2	M to H	L to M	L to H	○	○	○	○	+	—	○
LGHB 2	M to H	VL to M	H to VH	○	+	+	+	+	—	—
LGHP 2	M to H	M to H	L to M	+	—	—	○	○	+	○
LGET 2	VH	L to M	H to VH	○	+	+	○	○	—	—

(*1) LTL = Low Temperature Limit
HTPL = High Temperature Performance Limit
(*2) mm²/s at 40 °C / 104 °F = cSt.

(*3) LGGB 2 can withstand peak temperatures of 120 °C / 250 °F
(*4) LGWA 2 can withstand peak temperatures of 220 °C / 428 °F
(*5) LGHB 2 can withstand peak temperatures of 200 °C / 392 °F

Rust inhibiting properties	Description	Temperature range (*1)		Thickener / base oil	Base oil viscosity (*2)
		LTL	HTPL		
+	General purpose industrial and automotive	-30 °C -22 °F	120 °C 250 °F	Lithium soap / mineral oil	110
○	General purpose industrial and automotive	-30 °C -22 °F	120 °C 250 °F	Lithium soap / mineral oil	120
+	Extreme pressure	-20 °C -4 °F	110 °C 230 °F	Lithium soap / mineral oil	200
+	Food compatible	-20 °C -4 °F	110 °C 230 °F	Aluminium complex / medical white oil	130
+	High viscosity plus solid lubricants	-20 °C -4 °F	120 °C 250 °F	Lithium soap / mineral oil	500
+	Extremely high viscosity with solid lubricants	-10 °C -14 °F	120 °C 250 °F	Lithium-calcium soap / mineral oil	1 020
○	Low temperature, extremely high speed	-50 °C -58 °F	110 °C 230 °F	Lithium soap / PAO oil	18
○	Green biodegradable, low toxicity (*3)	-40 °C -40 °F	90 °C 194 °F	Lithium-calcium soap / synthetic ester oil	110
+	Extreme pressure, low temperature	-30 °C -22 °F	110 °C 230 °F	Lithium soap / mineral oil	200
+	High load, wide temperature	-40 °C -40 °F	110 °C 230 °F	Complex calcium sulphonate / Synthetic (PAO) - mineral oil	80
+	Wide temperature, extreme pressure (*4)	-30 °C -22 °F	140 °C 284 °F	Lithium complex soap / mineral oil	185
+	EP high viscosity, high temperature (*5)	-20 °C -4 °F	150 °C 302 °F	Complex calcium sulphonate / mineral oil	400
+	High performance polyurea grease	-40 °C -40 °F	150 °C 302 °F	Di-urea / mineral oil	96
○	Extreme temperature	-40 °C -40 °C	260 °C 500 °F	PTFE / synthetic (fluorinated polyether)	400

+ = Recommended

○ = Suitable

■ = Not suitable

Relubrication intervals

Choosing the right bearing grease for a certain application is critical to bearing performance. Applying the correct quantity of grease at the right intervals is of equal importance.

Over- or under-greasing as well as inadequate lubrication methods can shorten the bearing's service life.

For determining the right amount of grease and the correct relubrication intervals for a specific application, SKF has developed DialSet, a simple computerized relubrication calculation program. Calculated relubrication intervals are based on the latest lubrication theories published in the SKF General Catalogue (6000 EN) and depend on bearing type used, application conditions and properties of selected bearing grease.

Lubrication methods

The lubrication method used is equally important to the right bearing grease, quantity and lubrication intervals. Using lubricators, manual or automatic, facilitates proper lubricant supply to the application. Maintaining cleanliness when lubricating bearings is crucial, as contamination can cause the bearing to fail prematurely.

Using a grease meter in combination with a grease gun or pump during manual lubrication helps ensure the supply of the right quantity of grease. SKF's range of grease guns, pumps and lubrication accessories is designed for contamination-free grease supply as well as ease-of-use.

Continuous lubrication, using automatic lubricators or systems, provides the application with a consistent and controlled supply of bearing grease. This reduces the risk of over- or under-greasing and positively contributes to optimizing the bearing's service life. Additionally, automatic relubrication reduces the risk of contamination. Around-the-clock solutions offered by SKF provide precise and reliable grease supply, adjusted to the application's needs.

Grease failure process

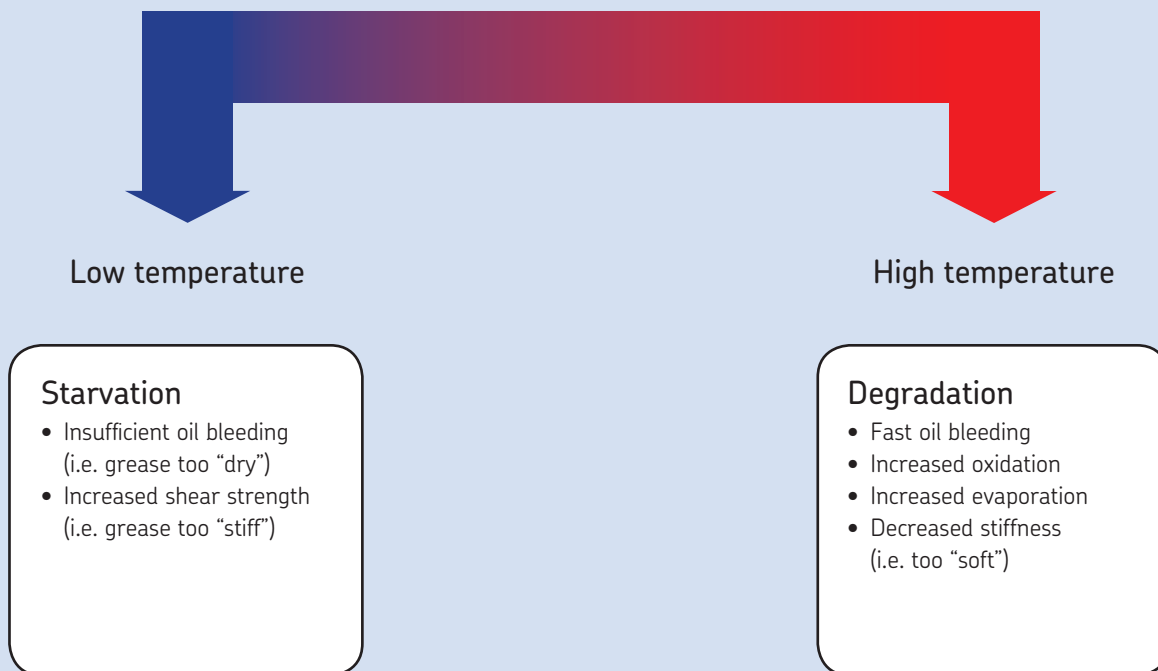

SKF bearing greases and their applications

LGMT 2

SKF general purpose industrial and automotive bearing grease

LGMT 2 is mineral oil based lithium soap thickened grease with excellent thermal stability within its operating temperature range. This premium quality, general purposes grease is suitable for a wide range of industrial and automotive applications.

- Excellent oxidation stability
- Good mechanical stability
- Excellent water resistance and rust inhibiting properties

Recommended applications

- Agricultural equipment
- Automotive wheel bearings
- Conveyors
- Small electric motors
- Industrial fans

Other uses

- Severe vibrations
- Rust inhibiting properties

LGMT 3

SKF general purpose industrial and automotive bearing grease

LGMT 3 is mineral oil based lithium soap thickened grease. This premium quality, general purpose grease is suitable for a wide range of industrial and automotive applications.

- Excellent rust inhibiting properties
- High oxidation stability within its recommended temperature range

Recommended applications

- Bearings >100 mm (3.9 in) shaft size
- Outer bearing ring rotation
- Vertical shaft applications
- Continuous high ambient temperatures >35 °C (95 °F)
- Propeller shafts
- Agricultural equipment
- Car, truck and trailer wheel bearings
- Large electric motors

Other uses

- Vertical shafts
- Severe vibrations

LGEP 2

SKF high load, extreme pressure bearing grease

LGEP 2 is mineral oil based lithium soap thickened grease with extreme pressure additives. This grease provides good lubrication in operating temperatures ranging from -20 °C (-4 °F) up to 110 °C (230 °F)

- Excellent mechanical stability
- Extremely good corrosion inhibiting properties
- Excellent EP performance

Recommended applications

- Pulp and paper making machines
- Jaw crushers
- Dam gates
- Work roll bearings in steel industry
- Heavy machinery, vibrating screens
- Crane wheels, sheaves

Other uses

- Severe vibrations
- Shock load or frequent start-up



LGWA 2

SKF high load, extreme pressure (EP), wide temperature range bearing grease

LGWA 2 is premium quality mineral oil based lithium complex grease with extreme pressure (EP) performance. LGWA 2 has such properties that it can be recommended for a wide range of industrial and automotive applications.

- Excellent lubrication at peak temperatures up to 220 °C (428 °F) for short periods
- Protection of wheel bearings operating under severe conditions
- Effective lubrication in wet conditions
- Good water and corrosion resistance
- Excellent lubrication under high loads and low speeds

Recommended applications

- Wheel bearings in cars, trailers and trucks
- Washing machines
- Electric motors

Other uses

- Oscillating movements
- Shock load or frequent start-up
- Rust inhibiting properties

LGHB 2

SKF high load, high temperature, high viscosity bearing grease

LGHB 2 is a premium quality, high viscosity, mineral oil based grease using the latest complex calcium, sulphonate soap technology. This grease contains no additives and the extreme pressure characteristics are created within the soap structure.

- Excellent anti-oxidation and anti-corrosion properties
- Good EP performance in applications running at high loads

Recommended applications

- Steel on steel plain bearings
- Pulp and paper making machines
- Asphalt vibrating screens
- Continuous casting machines
- Sealed spherical roller bearings operating up to 150 °C (302 °F)
- Withstands peak temperatures of 200 °C (392 °F)
- Work roll bearings in steel industry
- Mast rollers of fork lift trucks

Other uses

- Fast outer ring rotation
- Oscillating movements
- Severe vibrations
- Shock load or frequent start-up
- Rust inhibiting properties

LGHP 2

SKF high performance, high temperature bearing grease

LGHP 2 is premium quality mineral oil based grease, using a modern Polyurea (di-urea) thickener. It is suitable for ball (and roller) bearings required to run extremely quiet, operating at a wide temperature range from -40 °C (-40 °F) up to 150 °C (302 °F), at medium to high speeds.

- Extremely long life at high temperature
- Wide temperature range
- Excellent corrosion protection
- High thermal stability
- Good low temperature start-up performance
- Compatibility with common Polyurea greases
- Compatibility with lithium complex thickened greases
- Low noise characteristics
- Very good mechanical stability

(continued on following page)

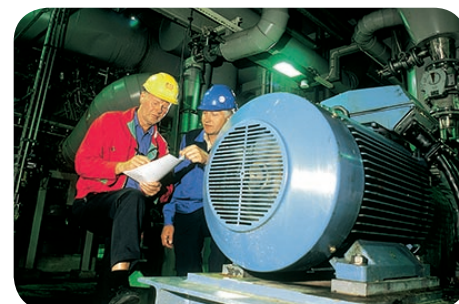

LGHP 2

Recommended applications

- Electric motors: small, medium and large
- Industrial fans, including high speed fans
- Water pumps
- Rolling bearings in textile, paper processing and drying machines
- Applications with high speed ball bearings operating at medium and high temperatures
- Clutch release bearings
- Kiln trucks and rollers
- Vertical shaft applications

Other uses

- Vertical shafts
- Low noise
- Rust inhibiting properties

LGET 2

SKF high temperature, extreme condition bearing grease

LGET 2 is premium quality, synthetic fluorinated oil based grease using a PTFE thickener. It has excellent lubrication properties at extremely high temperatures exceeding 200 °C (392 °F) up to 260 °C (500 °F).

- Long life in aggressive environments such as very reactive environments or areas with a presence of high purity gaseous oxygen or hexane
- Excellent oxidation resistance
- Good corrosion resistance
- Excellent water and steam resistance

Recommended applications

- Bakery equipment (ovens)
- Kiln truck wheels
- Load rollers in copying machines
- Wafer baking machines
- Textile dryers
- Film stretching tenders
- Electric motors running at extreme temperatures
- Emergency / hot fans
- Vacuum pumps

Other uses

- Fast outer ring rotation
- Oscillating movements

LGWM 1

SKF extreme pressure (EP) low temperature bearing grease

LGWM 1 is a mineral oil based grease using a lithium soap and containing extreme pressure additives. It is very suitable for the lubrication of bearings operating under both radial and axial loads e.g. transport screws.

- Good oil film formation at low temperatures down to -30 °C (-22 °F)
- Good pumpability at low temperature
- Good corrosion protection
- Good water resistance

Recommended applications

- Windmills
- Screw conveyors
- Centralized lubrication systems
- Spherical roller thrust bearing applications

Other uses

- Oscillating movements
- Shock load or frequent start-up
- Rust inhibiting properties



LGWM 2

SKF high load, wide temperature bearing grease

LGWM 2 has been developed for lubrication under a wide temperature range, high loads and wet environments. LGWM 2 is a synthetic-mineral oil based grease using the latest complex calcium sulphonate thickener technology. LGWM 2 is suitable for temperatures down to $-40\text{ }^{\circ}\text{C}$.

- Excellent corrosion protection
- Excellent mechanical stability
- Excellent high load lubricating capacity
- Good false brinelling protection
- Good pumpability down to low temperatures

Recommended applications

- Wind turbines
- Heavy duty off road applications
- Snow exposed applications
- Marine applications
- Spherical roller thrust bearing applications

LGLT 2

SKF low temperature, extremely high speed bearing grease

LGLT 2 is premium quality, fully synthetic oil based grease using lithium soap. Its unique thickener technology and its low viscosity oil (PAO) provide excellent lubrication performance at low temperatures ($-50\text{ }^{\circ}\text{C}$) and extremely high speeds, n.dm values of $1,6 \times 10^6$ can be reached.

- Low friction torque
- Low level of power loss
- Quiet running behavior
- Extremely good oxidation stability and resistance to water

Recommended applications

- Textile spinning spindles
- Machine tool spindles
- Instruments and control equipment
- Small electric motors used in medical and dental equipment
- In-line skates
- Printing cylinders
- Robots

Other uses

- Low noise
- Low friction

LGEM 2

SKF high viscosity bearing grease with solid lubricants

LGEM 2 is a premium quality, high viscosity, mineral oil based grease using a lithium soap containing molybdenum disulphide and graphite.

- Good lubrication for bearings operating under high loads and slow rotations
- Safe lubrication due to the inclusion of molybdenum disulphide and graphite

Recommended applications

- Rolling element bearings running at low speed and very high loads
- Jaw crushers
- Track laying machines
- Lift mast wheels
- Building machines such as mechanical rams, crane arms and crane hooks

Other uses

- Oscillating movements
- Severe vibrations
- Shock load or frequent start-up
- Rust inhibiting properties



LGEV 2

SKF extremely high viscosity bearing grease with solid lubricants

LGEV 2 is a premium quality, extremely high viscosity, mineral oil based grease using a lithium-calcium soap containing molybdenum disulphide and graphite.

- Excellent lubrication properties due to the inclusion of molybdenum disulphide and graphite solid
- Very suitable for lubricating large sized spherical roller bearings subject to high loads and slow rotation, a situation where microslip is likely to occur
- Extremely mechanically stable providing good water resistance and corrosion protection

Recommended applications

- Trunnion bearings on rotating drums
- Support and thrust rollers on rotary kilns and dryers
- Bucket wheel excavators
- Slewing ring bearings
- High pressure roller mills
- Crushers

Other uses

- Oscillating movements
- Severe vibrations
- Shock load or frequent start-up
- Rust inhibiting properties

LGGB 2

SKF green biodegradable bearing grease

LGGB 2 is biodegradable, low toxicity, synthetic ester oil based grease using a lithium-calcium thickener. It has excellent lubrication properties for a wide range of applications operating under different conditions.

- Compliance with current regulations on toxicity and biodegradability
- Good performance in applications with steel-on-steel spherical plain bearings, ball bearings and roller bearings
- Good low temperature start-up performance
- Good corrosion inhibiting properties
- Suitable for medium to high loads

Recommended applications

- Agricultural and forestry equipment
- Construction and earthmoving equipment
- Mining and conveying equipment
- Water treatment and irrigation
- Locks, dams, bridges
- Linkages, rod ends
- Other applications where contamination of the environment is a concern

Other uses

- Oscillating movements
- Severe vibrations
- Shock load or frequent start-up

LGFP 2

SKF food compatible bearing grease

LGFP 2 is clean, non-toxic bearing grease, which is based on medical white oil using an aluminium complex soap. This grease is formulated using only FDA* listed ingredients and is authorised by the NSF** for category H1*** service.

- Compliance with all existing legislation on food protection
- High resistance to water washout making it suitable for applications subject to frequent wash down
- Excellent grease life
- Excellent corrosion resistance
- An essentially neutral pH value

Recommended applications

- Bakery equipment
- Food processing equipment
- Multi-pack cassette bearings
- Wrapping machines
- Conveyor bearings
- Bottling machines

Other uses

- Rust inhibiting properties

* FDA - Food and Drug Administration

** NSF - National Sanitation Foundation

*** H1 - Incidental Contact with Food



Glossary of lubrication terms

Thickener or soap

Thickener or soap is the system which holds the oil and/or additives together to enable the lubricating grease to function. The thickener system is formed from either soaps or non-soaps.

The type of thickener gives the grease its typical characteristics. Soaps are based on lithium, calcium, sodium, barium or aluminium.

Non-soaps are based on organic or non-organic solids, bentonite clay, polyurea or silica gel.

Thickener compatibility chart

	Lithium	Calcium	Sodium	Lithium complex	Calcium complex	Sodium complex	Barium complex	Aluminium complex	Clay (Bentonite)	Common Polyurea	Calcium sulphonate complex
Lithium	+	○	–	+	–	○	○	–	○	○	+
Calcium	○	+	○	+	–	○	○	–	○	○	+
Sodium	–	○	+	○	○	+	+	–	○	○	–
Lithium complex	+	+	○	+	+	○	○	+	–	–	+
Calcium complex	–	–	○	+	+	○	–	○	○	+	+
Sodium complex	○	○	+	○	○	+	+	–	–	○	○
Barium complex	○	○	+	○	–	+	+	+	○	○	○
Aluminium complex	–	–	–	+	○	–	+	+	–	○	–
Clay (Bentonite)	○	○	○	–	○	–	○	–	+	○	–
Common Polyurea	○	○	○	–	+	○	○	○	○	+	+
Calcium sulphonate complex	+	+	–	+	+	○	○	–	–	+	+

+ = Compatible ○ = Test required – = Incompatible

Base oil compatibility chart

	Mineral/PAO	Ester	Polyglycol	Silicone: methyl	Silicone: phenyl	Polyphenyl-ether	PFPE
Mineral oil / PAO	+	+	–	–	+	○	–
Ester	+	+	+	–	+	○	–
Polyglycol	–	+	+	–	–	–	–
Silicone: methyl	–	–	–	+	+	–	–
Silicone: phenyl	+	+	–	+	+	+	–
Polyphenylether	○	○	–	–	+	+	–
PFPE	–	–	–	–	–	–	+

+ = Compatible ○ = Test required – = Incompatible

Note: SKF high performance, high temperature bearing grease LGHP 2 is not a common polyurea type grease. It is a di-urea bearing grease, which has successfully been tested for compatibility with lithium and lithium complex thickened greases i.e. LGHP 2 is compatible with such greases.

Base oil

The base oil is the oil inside the grease, which provides lubrication under operating conditions. Greases are normally based on mineral oils. Synthetic oils can be used for very specific applications such as extremely high or low temperatures. The base oil generally constitutes more than 70% of a grease's composition.

Base oil viscosity

Viscosity is a measure of a fluid's flow characteristics and is usually expressed in terms of the time required for a standard quantity of the fluid, at a given temperature, to flow through a standard orifice. Since viscosity decreases with increasing temperature, the temperature at which it is measured is always stated. The viscosity of base oils is always indicated as a kinematic viscosity abbreviated to cSt, at 40 °C (104 °F) and often also at 100 °C (212 °F).

Additives

Additives are used to provide additional characteristics such as wear and corrosion protection, friction reducing effects and preventing damage under boundary and mixed lubrication conditions.

Grease consistency/ penetration

A measure of the stiffness of a grease. The consistency is classified according to a scale developed by the NLGI (National Lubricating Grease Institute). This is based on the degree of penetration achieved by allowing a standard cone to sink into the grease at a temperature of 25 °C (77 °F) for a period of five seconds. The depth of penetration is measured on a scale of 10^{-1} mm and the softer greases allow the cone to penetrate further into the grease, hence the higher penetration number. The test method is in accordance with DIN ISO 2137. Refer to chart below

Drop point

The drop point is the temperature at which the grease sample, when heated, will begin to flow through an opening and is measured according to DIN ISO 2176. The drop point does not relate to the allowable operating service temperature of the grease.

Mechanical stability

The consistency of a rolling bearing grease should not alter, or only slightly be altered during the working life of the rolling bearing. Depending on the application, the following tests can be performed to evaluate the mechanical stability of a grease.

Prolonged penetration test

The grease sample is filled into a cup and, using an automatic device (called a grease worker) subjected to 100 000 double strokes. At the end of the test, the penetration of the grease is measured. The difference between the measured penetration at 60 strokes and after 100 000 strokes penetration is reported as the change in 10^{-1} mm.



Classification of greases by NLGI consistency number

NLGI number	ASTM worked penetration (10^{-1} mm)	Appearance at room temperature	NLGI number	ASTM worked penetration (10^{-1} mm)	Appearance at room temperature
000	445 - 475	Very fluid	3	220 - 250	Medium hard
00	400 - 430	Fluid	4	175 - 205	Hard
0	355 - 385	Semi-fluid	5	130 - 160	Very hard
1	310 - 340	Very soft	6	85 - 115	Extremely hard
2	265 - 295	Soft			

Roll stability test

The change in the grease structure (amount of softening or hardening) can be evaluated by filling a cylinder with a pre-specified quantity of grease. A roller is placed inside the cylinder and the complete unit is rotated for 2 hours at room temperature in accordance with ASTM D 1403. SKF modified the standard test procedure to reflect the application conditions under which the grease is used to either 72 or 100 hours at a test temperature of 80 °C (176 °F) or 100 °C (212 °F) respectively. At the end of the test period, the cylinder is allowed to cool to room temperature and the penetration of the grease is measured. The difference between the original penetration and the value measured is reported as the change in penetration in 10^{-1} mm.

SKF V2F test

The candidate grease is tested for mechanical stability using the following procedure. The test rig consists of a railway axle box subjected to vibration shocks of 1Hz from a bouncing hammer producing an acceleration force level between 12 - 15 g's. The test is run at two different speeds, 500 and 1 000 rpm. If the grease, which leaks from the housing through the labyrinth seal which is collected in a tray after 72 hours at 500 rpm, weighs less than 50 grams, the test is continued for a further 72 hours at 1 000 rpm. If the total amount of grease leakage after both tests (72 hours at both 500 and 1 000 rpm) does not exceed 150 grams, then a rating of 'M' is given. If the grease only fulfills the first part of the test (72 hours at 500 rpm with a grease leakage of 50 grams or less) but fails the second stage, a rating of 'm' is given. If the grease leakage after 72 hours at 500 rpm is greater than 50 grams, then it is rated as failed.

Corrosion protection

Lubricating greases should protect metal surfaces from corrosive attack in service. The corrosion protection properties of rolling bearing greases are evaluated using the SKF Emcor method, which is standardized under ISO 11007. Under this test method a mixture of lubricating grease and distilled water is present in the bearing. The bearing alternates during a defined test cycle between standstill and rotation at 80 rpm. At the end of the test cycle, the degree of corrosion is evaluated according to a scale between 0 (no corrosion) and 5 (very severe corrosion). A more severe test method is to use salt water to replace the distilled water following the standard test procedure. In addition, the test can also be carried out by continuously allowing water to flow or wash through the bearing arrangement during the test cycle. This test method is called the SKF Distilled Water Washout Test. The evaluation procedure is exactly the same as that used under the standardized method. However the procedure places greater demands on the corrosion protection properties of the grease.

Copper corrosion

Lubricating greases should protect copper alloys used in bearings from corrosive attack while in service. The copper corrosion protection properties of rolling bearing greases are evaluated using the standardized method DIN 51811. A copper strip is immersed in the grease sample and placed in an oven. The strip is then cleaned and the degradation is observed. The result is rated by a numerical system.

Water resistance

The water resistance of lubricating greases is measured in accordance with DIN 51 807 part 1. A glass strip is coated with the candidate grease, which is placed into a water-filled test tube. The test tube is immersed in a water bath for three hours at a specified test temperature. The change in the grease is evaluated visually and reported as a value between 0 (no change) and 3 (major change) along with the test temperature.

Oil separation

Lubricating greases release oil when stored for long periods of time or when used in bearings as a function of temperature. This phenomenon is necessary to ensure good lubrication. The degree of oil separation will depend upon the thickener, base oil and manufacturing method. A cup is filled with a given quantity of grease (which is weighed before the test) and a 100 gram weight placed on top of the grease. The complete unit is put into an oven at 40 °C (104 °F) for one week. At the end of the week, the amount of oil which has leaked through the sieve is weighed and reported as a percentage of weight loss. The amount of oil separation is measured in accordance with DIN 51 817.

Lubricating ability

The SKF R2F machine assesses the high temperature performance and lubricating ability of a grease, simulating the conditions under which large size bearings operate in housings. The test method is carried out under two different conditions. Test A is conducted at ambient temperature and Test B is conducted at 120 °C (248 °F). A pass rating in the unheated test (Test A) means that a grease can be used to lubricate larger rolling bearings at

normal operating temperatures and also in low vibrating applications.

A pass in the heated test (Test B) at 120 °C (248 °F) means that the grease is suitable for use in large roller bearings operating at elevated temperatures.

Rolling bearing grease life

The SKF ROF grease test machine determines the grease life and high temperature performance limit of a lubricating grease. Ten deep groove ball bearings are fitted into 5 housings and filled with a given quantity of grease. The test is undertaken at a pre-determined speed and temperature. Both an axial and radial load is applied and the bearings run until failure. The time to failure is recorded in hours and a Weibull life calculation is made at the end of the test period to establish

the grease life. This information can be used to determine relubrication intervals in an application.

EP performances

The 4-ball weld load test

This method evaluates the EP (Extreme Pressure) performance of a lubricating grease. This test method is standardized under DIN 51 350/4. Three steel balls are held in a cup and a fourth ball is rotated against the three balls at a given speed. A starting load is applied and increased at predetermined intervals until the rotating ball seizes and welds to the three stationary balls. The test indicates the point at which the extreme pressure limit of the grease is exceeded. Greases can be considered as EP greases when the weld load is higher than 2 600 N.

The 4-ball wear scar test

This test is performed with the same rig used in the 4-ball weld load test. 1 400 N are applied on the fourth ball for one minute. Then the wear on the three balls is measured. A standard test uses a load of 400 N. However, SKF has decided to increase that to 1 400 N in order to make the test relevant for bearing applications.

False brinelling

Anti-fretting properties of a grease can be relevant for certain applications. SKF can assess these properties using the FAFNIR test standardized as ASTM D4170. Two ball thrust bearings are loaded and oscillated. The wear on each bearing is then measured. Greases offer good fretting protection when the measured wear is below 7 mg.

Conversion table

Variable	SI unit	Conversion of previous units to the SI system	Conversion of US units to the SI system
Length	1 m	= 100 cm = 1000 mm	1 inch (in) = 25.4 mm 1 foot (ft) = 0.3048 m
	Volume	1 m ³ = 1000 dm ³ = 1000 l 1 dm ³ = 1000 cm ³ = 1 l 1 cm ³ = 1000 mm ³	1 in ³ = 16.387 cm ³ 1 ft ³ = 28.316 847 l 1 US gallon (gal [US]) = 231.00 in ³ = 3.7854 l
Mass (weight)	1 kg = 1000 g		1 kg = 2.2046 pounds (lb)
Force	1 Newton (N) = 1 m · kg · s ⁻²	1 kp = 9.81 N ≈ 10 N	= 9.806 65 N
Pressure	1 Pascal (Pa) = 1 N · m ⁻²	1 bar = 0.1 MPa	1 bar = 14.5038 psi 1 MPa = 145.038 psi
Volumetric flow	m ³ /s	1 l/min = 1.667 · 10 ⁻⁵ m ³ /s	1 gal (US)/min = 3.7854 dm ³ /min = 6.31 · 10 ⁻⁵ m ³ /s
Viscosity ν kinematic	1 m ² · s ⁻¹	1 cSt = 1 mm ² · s ⁻¹	1 m ² · s ⁻¹ = 0.0929 ft ² · s ⁻¹ 1 ft ² · s ⁻¹ = 10.7693 m ² · s ⁻¹
Temperature	t in °C (Celsius)		T _F (°F) = 9/5 t _C + 32

Chain oil range

Extending chain life

SKF chain oils come in three convenient sizes to suit the needs of most chain applications in industrial environments. The chain oils, medium temperature, high temperature, and food compatible (NSF H1), are available in 5 liter (1.32 gallon) cans, and as an oil fill for the SKF SYSTEM 24 single point automatic lubricator.

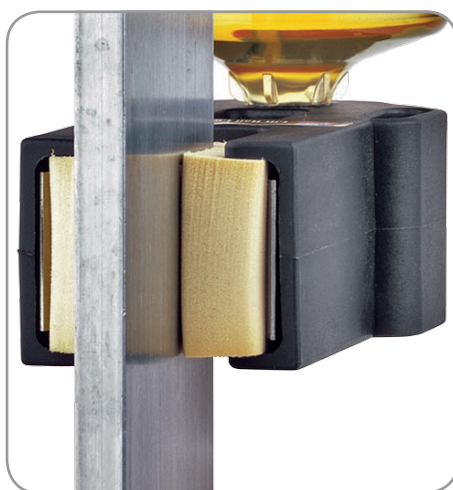

Ordering details

Designation	Description
LHFP 150/0.4	400 ml (13,52 oz.) aerosol can
LHFP 150/5	5 litre (1,32 gallon) can
LAGD 125/FHF15 */**	125 ml (4,25 fl oz. US) SKF SYSTEM 24 LAGD unit filled with food processing oil (viscosity ISO 150)
LAGE 125/HFP15	122 ml (4,1 fl oz. US) complete unit SKF SYSTEM 24 LAGE filled with food processing oil (viscosity ISO 150)
LAGE 250/HFP15	250 ml (8,5 fl oz. US) complete unit SKF SYSTEM 24 LAGE filled with food processing oil (viscosity ISO 150)
LHFP 150/EML12	122 ml (4,1 fl oz. US) refill set for SKF SYSTEM 24 LAGE filled with food processing oil (viscosity ISO 150)
LHFP 150/EML25	250 ml (8,5 fl oz. US) refill set for SKF SYSTEM 24 LAGE filled with food processing oil (viscosity ISO 150)
LHHT 265/0.4	400 ml (13,52 oz.) aerosol can
LHHT 265/5	5 litre (1,32 gallon) can
LAGD 125/HHT26 *	125 ml (4,25 fl oz. US) SKF SYSTEM 24 LAGD unit filled with synthetic high temperature chain oil (viscosity ISO 265)
LAGE 125/HHT26	122 ml (4,1 fl oz. US) complete unit SKF SYSTEM 24 LAGE filled with synthetic high temperature chain oil (viscosity ISO 265)
LAGE 250/HHT26	250 ml (8,5 fl oz. US) complete unit SKF SYSTEM 24 LAGE filled with synthetic high temperature chain oil (viscosity ISO 265)
LHHT 265/EML12	122 ml (4,1 fl oz. US) refill set for SKF SYSTEM 24 LAGE filled with synthetic high temperature chain oil (viscosity ISO 265)
LHHT 265/EML25	250 ml (8,5 fl oz. US) refill set for SKF SYSTEM 24 LAGE filled with synthetic high temperature chain oil (viscosity ISO 265)
LHMT 68/0.4	400 ml (13,52 oz.) aerosol can
LHMT 68/5	5 litre (1,32 gallon) can
LAGD 125/HMT68 *	125 ml (4,25 fl oz. US) SKF SYSTEM 24 LAGD unit filled with mineral EP type chain oil (viscosity ISO 68)
LAGD 60/HMT68*	60 ml (2,03 fl oz. US) SKF SYSTEM 24 LAGD unit filled with mineral EP type chain oil (viscosity ISO 68)
LAGE 125/HMT68	122 ml (4,1 fl oz. US) complete unit SKF SYSTEM 24 LAGE filled with mineral EP type chain oil (viscosity ISO 68)
LAGE 250/HMT68	250 ml (8,5 fl oz. US) complete unit SKF SYSTEM 24 LAGE filled with mineral EP type chain oil (viscosity ISO 68)
LHMT 68/EML125	122 ml (4,1 fl oz. US) refill set for SKF SYSTEM 24 LAGE filled with mineral EP type chain oil (viscosity ISO 68)
LHMT 68/EML250	250 ml (8,5 fl oz. US) refill set for SKF SYSTEM 24 LAGE filled with mineral EP type chain oil (viscosity ISO 68)

* Includes non-return valve ** Not available in USA and Canada

SKF Dry Film Lubricant LDTS 1

SKF Dry Film Lubricant LDTS 1 is specially developed for automatic lubrication of flat top chain conveyors in the beverage processing industry. It adheres very well on all treated surfaces and has outstanding properties.

The lubricant consists of synthetic oil and is doped with PTFE as solid lubricant. LDTS 1 is NSF* H1** certified for use where incidental contact with food cannot be excluded.

- NSF H1 certified
- Recommended for conveyors using plastic chains
- Excellent lubricating properties

* NSF - National Sanitation Foundation

** H1 - Incidental Contact with Food

Recommended applications:

- Conveyors in bottling lines
- Applications for the following packaging types:
 - Carton packs
 - Cans
 - PET bottles

Note:

For more information on dry lubrication systems see page 59



Technical data

Designation

LDTS 1

Composition

Mineral oils, hydrocarbons, additives, PTFE

Colour

White

Operating temperature range

- 5 to 60 °C (23 to 140 °F)

Viscosity at 40 °C (104 °F)

ca. 11 mm²/s

Pour point, °C

< 0

Density (20 °C/ 68 °F)

ca. 843 kg/m³

Flash point of the preparation

ca. 100 °C

Flash point after evaporation

> 170 °C

of the solvent

NSF registration

H1 (registration no: 139739)

Ordering details

Designation

Description

LDTS 1 / 5

5L can

Product packaged in 5 liter cans; 4 cans per case

Anti-fretting Agent LGAF 3E

SKF LGAF 3E is a greasy, smooth paste especially developed to prevent fretting corrosion between metal surfaces in loose fit arrangements. Fretting corrosion is caused by very slight oscillations or by vibrations, which may lead to serious damage in bearings and other machine parts and can make dismantling almost impossible.

- Reduction of fretting corrosion providing easier dismantling of bearings
- Better sliding on designed loose bearing arrangements such as vibrating screens, truck and car wheel bearings
- Easier removal of general industrial components in a wide range of applications such as nuts, bolts, flanges, studs, bearings, guide pins, couplings, jack screws, lathe centers, push rods, and spline shafts



Anti-corrosive Agent LHRP 1

SKF LHRP 1 provides excellent long-term corrosion protection to ferrous and non-ferrous metals. When applied, it leaves a stable rust protection film over the metal component.

- Excellent rust protection in high humidity environments (tests at 30 °C / 80 °F - 90 % relative humidity indicates full protection for at least one year)
- Excellent long-term indoor storage protection



Technical data

	Chemicals and oils LHRP 1 (page 22)		LGAF 3E (page 22)			LHMT 68, LHHT 265, LHFP 150 (page 20)		
	LHRP 1	LGAF 3E	LHMT 68	LHHT 265	LHFP 150			
Description	Anti-corrosive agent	Anti-fretting paste	Medium temperature oil	High temperature oil	Food compatible, NSF H1 oil			
Specific gravity	0,815	1,19	0,85	0,91	0,85			
Color	Hazy brown	White-beige	Yellow-brown	Yellow-orange	Colorless			
Base oil type	Mineral	Mineral and synthetic	Mineral	Synthetic ester	Synthetic ester			
Thickener	Not applicable	Lithium soap	Not applicable	Not applicable	Not applicable			
Operating temperature range, °C (°F)		-25 to 250 °C (-13 to 482 °F)	-15 to 90 °C (5 to 194 °F)	Up to 250 °C (482 °F)	-30 to 120 °C (-22 to 248 °F)			
Base oil viscosity: 20 °C, mm ² /s 40 °C, mm ² /s 100 °C, mm ² /s	not valid because of thixotropic nature	17,5	ISO VG 68 approx. 9	approx. 265 approx. 30	ISO VG 150 approx. 19			
Flash point	39 °C (102 °F)		200 °C (392 °F)	approx. 260 °C (500 °F)	> 200 °C (392 °F)			
Pour point	-20 °C (-4 °F)		-15 °C (5 °F)		< -30 °C (-22 °F)			
NSF approval	Not applicable	Not applicable	Not applicable	Not applicable	H1 (No: 136858)			
Available pack sizes	5 liter can 180 liter drum	0,5 kg can	125 ml automatic lubricator SYSTEM 24 5 liter can	125 ml automatic lubricator SYSTEM 24 5 liter can	125 ml automatic lubricator SYSTEM 24 5 liter can			
Designation	LHRP 1 / (pack size)	LAGF 3E / 0.5	LAGD 125 / HMT68 LHMT 68 / (pack size)	LAGD 125 / HHT26 LHHT 265 / (pack size)	LAGD 125 / HFP15 LHFP 150 / (pack size)			



Bearing greases (pages 11 - 15)	LGMT 2	LGMT 3	LGEP 2
DIN 51825 code	K2K-30	K3K-30	KP2G-20
NLGI consistency class	2	3	2
Soap type / thickener	Lithium	Lithium	Lithium
Color	Red brown	Amber	Light brown
Base oil type	Mineral	Mineral	Mineral
Operating temperature range	-30 to 120 °C (-22 to 250 °F)	-30 to 120 °C (-22 to 250 °F)	-20 to 110 °C (-4 to 230 °F)
Dropping point DIN ISO 2176	>180 °C (>356 °F)	>180 °C (>356 °F)	>180 °C (>356 °F)
Base oil viscosity: 40 °C, mm ² /s 100 °C, mm ² /s	110 11	120 - 130 12	200 16
Penetration DIN ISO 2137: 60 strokes, 10 ⁻¹ mm 100 000 strokes, 10 ⁻¹ mm	265 - 295 +50 max. (325 max.)	220 - 250 280 max.	265 - 295 +50 max. (325 max.)
Mechanical stability: Roll stability, 50 hrs at 80 °C, 10 ⁻¹ mm SKF V2F test 'M'	+50 max. 'M'	295 max. 'M'	+50 max.
Corrosion protection: SKF Emcor: - standard ISO 11007 - water washout test - salt water test (100% seawater)	0 - 0 0 - 0 0 - 1*	0 - 0 0 - 0 -	0 - 0 0 - 0 1 - 1*
Water resistance DIN 51 807/1, 3 hrs at 90 °C	1 max.	2 max.	1 max.
Oil separation DIN 51 817, 7 days at 40 °C, static, %	1 - 6	1 - 3	2 - 5
Lubrication ability SKF R2F, running test B at 120 °C	Pass	Pass	Pass
Copper corrosion DIN 51 811, 110 °C	2 max. (130 °C / 266 °F)	2 max.	2 max. (100 °C)
Rolling bearing grease life SKF R0F test L50 life at 10 000 rpm, hrs		1 000 min. at 130 °C (266 °F)	
EP performance Wear scar DIN 51350/5, 1 400 N, mm 4-ball test, welding load DIN 51350/4			1,4 max. 2 800 min.
Fretting corrosion ASTM D4170 (mg)			5,7*
Available pack sizes	35, 200 g tube 420 ml cart. 1, 5, 18, 50, 180 kg	420 ml cart. 1, 5, 18, 50, 180 kg	420 ml cart. 1, 5, 18, 50, 180 kg
Designation	LGMT 2 / (pack size)	LGMT 3 / (pack size)	LGEP 2 / (packsize)

* Typical value

Bearing greases (pages 11 - 15)	LGFP 2	LGLT 2	LGHP 2
DIN 51825 code	K2G-20	K2G-50	K2N-40
NLGI consistency class	2	2	2 - 3
Soap type / thickener	Aluminium complex	Lithium	Di-urea
Color	Transparent	Beige	Blue
Base oil type	Medical white oil	PAO	Mineral
Operating temperature range	-20 to 110 °C (-4 to 230 °F)	-50 to 110 °C (-58 to 230 °F)	-40 to 150 °C (-40 to 300 °F)
Dropping point DIN ISO 2176	>250 °C (>482 °F)	>180 °C (>356 °F)	>240 °C (>464 °F)
Base oil viscosity: 40° C, mm ² /s 100° C, mm ² /s	130 7,3	18 4,5	96 10.5
Penetration DIN ISO 2137: 60 strokes, 10 ⁻¹ mm 100 000 strokes, 10 ⁻¹ mm	265 - 295 +30 max.	265 - 295 +50 max.	245 - 275 365 max.
Mechanical stability: Roll stability, 50 hrs at 80 °C, 10 ⁻¹ mm SKF V2F test		+380 max.	365 max. -
Corrosion protection: SKF Emcor: - standard ISO 11007 - water washout test - salt water test (100% seawater)	0 - 0	0 - 1	0 - 0 0 - 0 0 - 0
Water resistance DIN 51 807/1, 3 hrs at 90 °C	1 max.	1 max.	1 max.
Oil separation DIN 51 817, 7 days at 40 °C, static, %	1 - 5	< 4	1 - 5
Lubrication ability SKF R2F, running test B at 120 °C			Pass
Copper corrosion DIN 51 811, 110 °C		1 max. (150 °C / 300 °F)	1 max.
Rolling bearing grease life SKF ROF test L50 life at 10 000 rpm, hrs	1 000 min. at 110 °C (230 °F)	> 1 000, 20 000 rpm at 100 °C (212 °F)	1 000 min. at 150 °C (302 °F)
EP performance Wear scar DIN 51350/5, 1 400 N, mm 4-ball test, welding load DIN 51350/4	1 100 min.	2 000 min	- -
Fretting corrosion ASTM D4170 (mg)			7 *
Available pack sizes	420 ml cart. 1, 18, 180 kg SYSTEM 24 (LAGD / LAGE)	200 g tube 1, 25, 180 kg	420 ml cart. 1, 5, 18, 50, 180 kg SYSTEM 24
Designation	LGFP 2 / (pack size)	LGLT 2 / (pack size)	LGHP 2 / (pack size)

* Typical value

Bearing greases (pages 11 - 15)	LGGB 2	LGWA 2	LGHB 2	LGEB 2
DIN 51825 code	KPE 2K-40	KP2N-30	KP2N-20	KFK2U-40
NLGI consistency class	2	2	2	2
Soap type /thickener	Lithium / calcium	Lithium complex	Complex calcium sulphonate	PTFE
Color	Off white	Amber	Brown	Whitish cream
Base oil type	Synthetic ester	Mineral	Mineral	Synthetic (fluorinated polyether)
Operating temperature range	-40 to 120 °C (-40 to 250 °F)	-30 to 140 °C (-22 to 284 °F)	-20 to 150 °C (-4 to 300 °F)	-40 to 260 °C (-40 to 500 °F)
Dropping point DIN ISO 2176	>170 °C (>338 °F)	> 250 °C (482 °F)	>220 °C (>428 °F)	> 300 °C (572 °F)
Base oil viscosity: 40 °C, mm ² /s 100 °C, mm ² /s	110 13	185 15	400 - 450 26,5	400 38
Penetration DIN ISO 2137: 60 strokes, 10 ⁻¹ mm 100 000 strokes, 10 ⁻¹ mm	265 - 295 +50 max. (325 max.)	265 - 295 +50 max. (325 max.)	265 - 295 -20 - +50 (325 max.)	265 - 295
Mechanical stability: Roll stability, 50 hrs at 80 °C, 10 ⁻¹ mm Roll stability, 72 hrs at 100 °C, 10 ⁻¹ mm SKF V2F test	+70 max. (350 max.)	+50 max. change	-20 - +50 change 'M'	± 30 max. (130 °C/266° F) 'M'
Corrosion protection: SKF Emcor - standard ISO 11007 - water washout test - salt water test (100% seawater)	0 - 0	0 - 0 0 - 0	0 - 0 0 - 0 0 - 0*	1 - 1
Water resistance DIN 51 807 / 1.3 hrs at 90 °C	0 max.	1 max.	1 max.	0 max.
Oil separation DIN 51 817, 7 days at 40 °C, static, %	0,8 - 3	1 - 5	1 - 3 (at 60 °C)	13 max. (30 hrs at 200 °C)
Lubrication ability SKF R2F, running test B	Pass at 100 °C* (212 °F)	Pass at 100 °C (212 °F)	Pass at 140 °C (284 °F)	
Copper corrosion DIN 51 811, 100 °C		2 max. (150 °C/300 °F)	2 max. (150 °C/300 °F)	1
Rolling bearing grease life SKF ROF test L50 life at 10 000 rpm, hrs	> 300 at 120 °C (250 °F)		> 1 000 at 130 °C (266 °F)	> 700, 5 600 rpm* at 220 °C (428 °F)
EP performance Wear scar DIN 51350/5, 1 400 N, mm 4-ball test, welding load DIN 51350/4	1,8 max. 2 600 min.	1,6 max. 2 600 min.	0.86* 4 800 N*	8 000 min.
Fretting corrosion ASTM D4170 (mg)			0 *	
Available pack sizes	420 ml cart. 5, 18, 180 kg SYSTEM 24	35, 200 g tube 420 ml cart. 1, 5, 50, 180 kg SYSTEM 24	420 ml cart. 5, 18, 50, 180 kg SYSTEM 24	50 g (25 ml) syringe 1 kg
Designation	LGGB 2/ (pack size)	LGWA 2/ (pack size)	LGHB 2/ (pack size)	LGEB 2/ (pack size)

* Typical value

Bearing greases (pages 11 - 15)	LGEM 2	LGEV 2	LGWM 1	LGWM 2
DIN 51825 code	KPF2K-20	KPF2K-10	KP1G-30	KP2G-40
NLGI consistency class	2	2	1	1 - 2
Soap type /thickener	Lithium	Lithium / calcium	Lithium	Complex calcium sulphionate
Color	Black	Black	Brown	Yellow
Base oil type	Mineral	Mineral	Mineral	Synthetic(PAO)/Mineral
Operating temperature range	-20 to 120 °C (-4 to 250 °F)	-10 to 120 °C (14 to 250 °F)	-30 to 110 °C (-22 to 230 °F)	-40 to 110 °C (-40 to 230 °F)
Dropping point DIN ISO 2176	>180 °C (356 °F)	>180 °C (356 °F)	>170 °C (338 °F)	> 300 °C
Base oil viscosity: 40 °C, mm ² /s 100 °C, mm ² /s	500 32	1020 58	200 16	80 8,6
Penetration DIN ISO 2137: 60 strokes, 10 ⁻¹ mm 100 000 strokes, 10 ⁻¹ mm	265 - 295 325 max.	265 - 295 325 max.	310 - 340 +50 max.	280 - 310 +30 max
Mechanical stability: Roll stability, 50 hrs at 80 °C, 10 ⁻¹ mm Roll stability, 72 hrs at 100 °C, 10 ⁻¹ mm SKF V2F test ASTM D1831, 100h at 80°C, 10 ⁻¹ mm ASTM D1831, 100h at 80°C + 20% H ₂ O, 10 ⁻¹ mm	345 max. 'M'	+50 max. 'M'	+2*	+2* -9*
Corrosion protection: SKF Emscor - standard ISO 11007 - water washout test - salt water test (100% seawater)	0 - 0	0 - 0 0 - 0* 0 - 0*	0 - 0 0 - 0	0 - 0 0 - 0
Water resistance DIN 51 807 / 1.3 hrs at 90 °C	1 max.	1 max.	1 max.	1 max.
Oil separation DIN 51 817, 7 days at 40 °C, static, %	1 - 5	1 - 5	8 - 13	3 max.
Lubrication ability SKF R2F, running test B SKF R2F, Cold chamber test (+20 °C to -30 °C)	Pass at 100 °C (212 °F)			pass
Copper corrosion DIN 51 811, 100 °C	2 max. (90 °C/194 °F)	1 max.	2 max.	2 max.
Rolling bearing grease life SKF ROF test L50 life at 10 000 rpm, hrs				1 824* at 110°C
EP performance Wear scar DIN 51350/5, 1 400 N, mm 4-ball test, welding load DIN 51350/4	1,4 max. 3 000 min.	1,2 max. 3 000 min.	1,8 max. 3 200 min.*	1,5 max 4 600 N
Fretting corrosion ASTM D4170 (mg) ASTM D4170 FAFNIR test at -20°C, mg			5,5 *	5,2* 1,1*
Available pack sizes	420 ml cart. 5, 18, 180 kg SYSTEM 24	35 g tube 420 ml cart. 5, 18, 50, 180 kg	420 ml cart. 5, 50, 180 kg	420 ml cart. 5, 18, 50, 180 kg SYSTEM 24
Designation	LGEM 2/ (pack size)	LGEV 2/ (pack size)	LGWM 1/ (pack size)	LGWM 2/ (packsize)

* Typical value



Manual lubrication

Grease Packer LAGP 400	30
Bearing Packer VKN 550	30
One-hand Operated Grease Gun LAGH 400	30
Grease Guns 1077600 and TLGH 1	31
Grease Meter LAGM 1000E	31
Battery-driven Grease Gun LAGG 400B	32
Piston Pump with Block Feeder PF-VPBM	33
Technical data	34

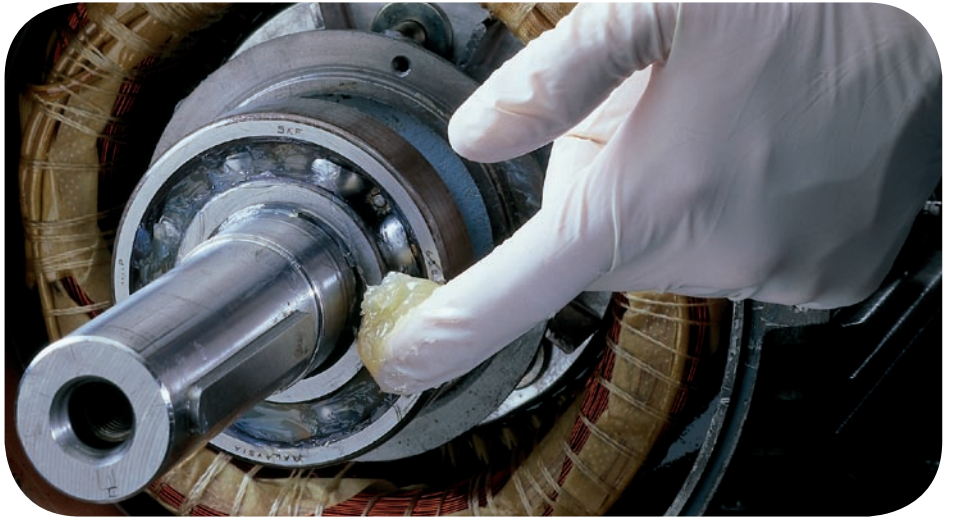
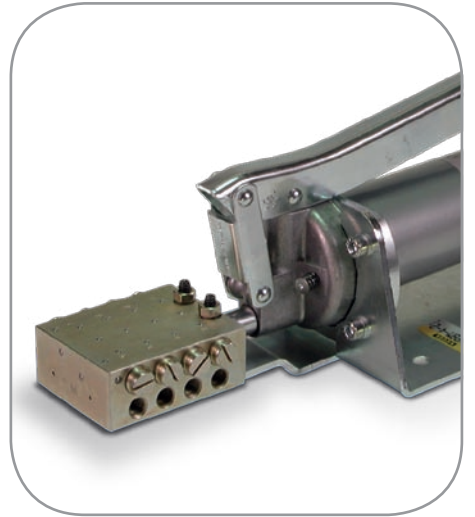

Grease Packer LAGP 400

To lubricate open bearings

The grease packer LAGP 400 is a low-pressure alternative for emptying SKF grease cartridges. It provides an easy and clean alternative to manual grease packing of open bearings.

- Supplied with three spout caps
- Applies grease to open bearings or open gears



Bearing Packer VKN 550

Contamination-free grease filling

The SKF bearing packer VKN 550, is a sturdy, easy-to-use, efficient and effective bearing grease packer. It can also be used in combination with a standard grease gun, air-operated grease pump or grease filler pump. Although specially designed for taper roller bearings, the SKF bearing packer works for any type of open bearing which needs to be 100% pre-filled with grease.

- Flushes the grease between the rolling elements where it matters most, prolonging the bearing service life
- Closed system and the cover lid prevent ingress of dirt, virtually eliminating contamination
- Allows the operator to pre-fill bearings with grease in a quick and clean way
- Prevents unnecessary grease loss
- Economical and environmentally friendly



One-hand Operated Grease Gun LAGH 400

Easy grease filling with one hand

Suitable for grease filler pumps and grease cartridges. Ergonomic design, flexible hose and ability to mount the hose vertically and horizontally, make it easy to use.

- Easy-to-use: only one hand is needed to operate the gun
- Refillable: grease-filling nipple and de-airing valve allow filling up by filler or grease pump
- Heavy duty: operating pressure up to 300 bar
- 0,8 cm³ (0.05 in³) volume/stroke
- Flexible hydraulic type hose: can be bent, can be mounted both horizontally and vertically on the gun



Grease Guns 1077600 and TLGH 1

Easy grease filling

The SKF Grease Guns are ideal for agricultural, industrial and construction industries and for private use. The SKF Grease Guns are delivered with a 175 mm (6.9 in) long extension pipe with hydraulic gripping nozzle. A flexible 500 mm (19.7 in) long pressure hose with hydraulic gripping nozzle is available as an accessory.

The 1077600 is also available with a with 300 mm (12 inch) high pressure hose with a hydraulic gripping nozzle; 1077600H.

The 1077600 is also available as a complete set; 1077600/SET including 3 extension pipes, high pressure hose, packed in a carrying case.

- For use with cartridges and loose grease
- Knurled body for firm and safe grip
- High quality steel is dent-resistant for easy cartridge loading
- Special piston design for smooth emptying of cartridges
- 400 bar (5,800 psi) maximum pressure
- 1077600: 1,5 cm³ (0.092 in³) volume/stroke
- TLGH 1: 0.9 cm³ (0.055 in³) volume/stroke

Ordering details

Designation	Description
1077600	Grease gun with extension pipe
1077600H	Grease gun with flexible hose
1077601	Flexible hose
1077600/SET	Grease gun set



Grease Meter LAGM 1000E

Accurate grease quantity measurement for adequate lubrication

It is generally difficult to determine the correct quantity of grease when manually lubricating bearings, either using a grease gun or pump, which can result in either over- or under-greasing the bearing. That can negatively affect the bearing's service life and possibly result in machine breakdown. The SKF grease meter LAGM 1000E accurately measures grease discharge in volume or weight, in both metric (cm³ or g) and US units (fl. oz. or oz). It has a high maximum pressure of 700 bar (10 000 psi), making it ideal for use in combination with many types of grease guns and pumps.

- Measures grease discharge in volume or weight, making conversion calculations unnecessary
- High accuracy facilitates adequate bearing lubrication, reducing the risk of over- or under-greasing
- Suitable for all SKF bearing greases of consistency classes up to NLGI 3
- An oil and grease resistant rubber sleeve protects the electronics in case of impact
- The backlit LCD displays large and clear-to-read digits, including "low battery" indication
- Small, compact and lightweight design – only 0,3 kg (0.66 lb.)
- Corrosion-free aluminium housing
- Easy to install and use



Battery-driven Grease Gun LAGG 400B

Quick and easy grease filling

The Battery-driven grease gun LAGG 400B is a high quality grease gun suitable for lubricating bearings, machines, vehicles and other applications. Ergonomically designed and user-friendly, the grease gun can be used with standard SKF grease cartridges (420 ml) or filled with approximately 500 cm³ (17 fl. oz.) of loose grease.

- Compared to hand operated grease guns, a 420 ml cartridge can be emptied in approximately 10 minutes with minimum effort, resulting in significant cost and time savings
- Electrical operation and the ergonomic design of the hand grip helps reduce operator fatigue compared to manual methods
- Easy-to-use one hand operation makes the grease gun user-friendly
- Supplied with various electrical plugs. Two power supply versions (230 and 110V charger) makes it operational worldwide
- Battery operation allows use in almost all environments without use of a main electrical supply
- Long battery life (1 000 charging cycles) helps reduce product life costs
- Refillable: grease filling nipple and de-airing valve allow filling up by filler or grease pump
- Safety valve setting set to 400 bar (5 800 psi) helps increase operator safety
- Supplied with M10x1 nozzle, interchangeable with SKF hoses, SKF grease meter LAGM 1000E and other accessories
- Equipped with shoulder strap helps further reduce operator fatigue and facilitates ease of mobility from job to job



Replacement parts

Designation	Description
LAGG 400B-1	High pressure hose 750 mm (29.5 in) with gripping nozzle
LAGG 400B-2	Battery pack

Piston Pump with Block Feeder PF-VPBM

Manually operated

The piston pumps with a block feeder are used on farm machinery, small stackers and construction machinery as well as motor vehicle superstructures.

The piston pump has 6 to 12 lubricant outlets depending on the block feeder.

Every stroke of the lever delivers 2 cm³ of lubricant to the feeder.

Also available without block feeder with only one M10 x 1 outlet on the front (order no. VGBL 169-000-146). The level of the lubricant in the cartridge can be checked by pulling out the cartridge until distinct resistance is felt. When the cartridge is full, the piston rod can be pulled out approximately 415 mm.

Pay attention to cleanliness when changing cartridges, and proceed as follows:

- a. Open the toggle-type fastener
- b. Unscrew the gun tube
- c. Pull piston rod out to the stop
- d. Change the cartridge
- e. Screw in the gun tube
- f. Close the toggle-type fastener
- g. Loosen the lock, push in the piston rod up to the stop
- h. Actuate the vent valve until grease emerges

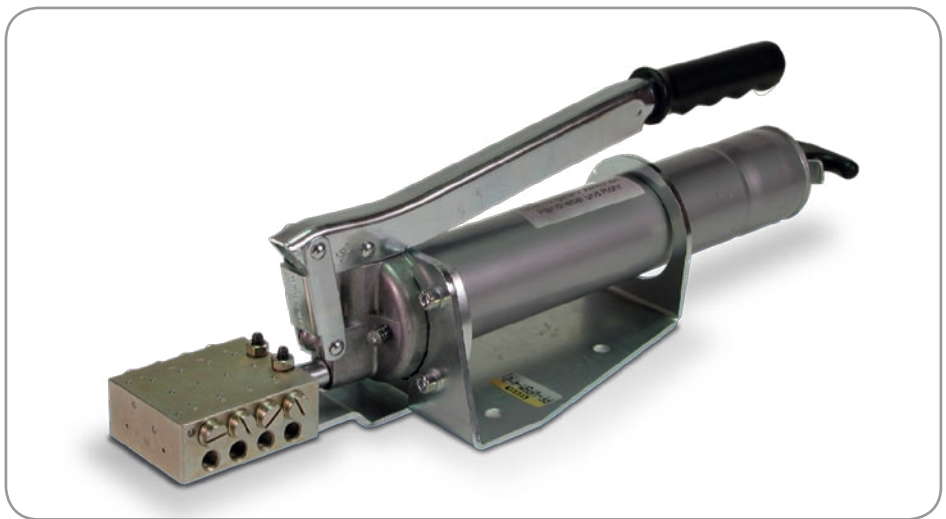
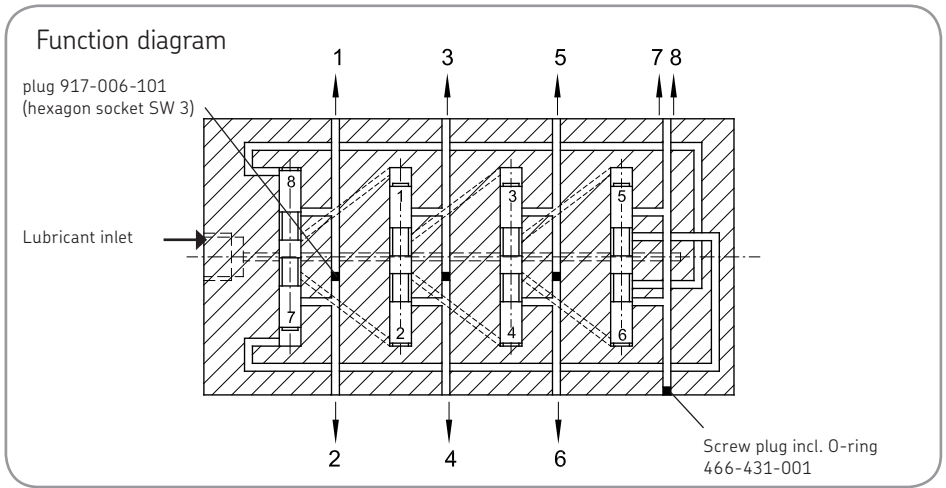

Ordering details		
Progressive feeder	Number of outlet pairs (pistons)	Number of maximum outlets
VPBM-3	3	6
VPBM-4	4	8
VPBM-5	5	10
VPBM-6	6	12

Ordering details	
Complete unit	Number of outlets
PF-VPBM-3-2	6
PF-VPBM-4-2	8
PF-VPBM-5-2	10
PF-VPBM-6-2	12
169-000-146	1 (Gun only)

*See Accessories chapter for tubing, fittings and connectors.
See Lubricants chapter for grease cartridges.*

Technical data

LAGP 400 (page 30)

Designation	LAGP 400
Maximum volume per stroke	20 cm ³ (1.2 in ³)
Material	Steel and polyethylene
Length	360 mm (14 in)
Weight	0,35 kg (0.77 lb)

VKN 550 (page 30)

Designation	VKN 550
Description	Bearing grease packer
Weight	1,8 kg (3.9 lb)
Material	Zinc plated, metal finish
Suitable greases	Approved for all SKF greases
Other greases	NLGI class 000 to 2
Bearing range	
- Inner diameter d	19 to 120 mm
- Outer diameter D	Max 200 mm

LAGH 400 (page 30)

Designation	LAGH 400
Maximum pressure	300 bar (4 350 psi)
Volume/stroke	approx. 0,8 cm ³ (0.049 in ³)
Length	370 mm (14.6 in)
Weight	1,5 kg (3.3 lb)

1077600 (page 31)

Designation	1077600
Maximum pressure	400 bar (5 800 psi)
Volume/stroke	1,5 cm ³ (0.09 in ³)
Length	380 mm (14.9 in)
Weight	1,5 kg (3.3 lb)

LAGM 1000E (page 31)

Designation	LAGM 1000E
Housing material	Aluminium, anodized
Weight	0,3 kg (0.66 lb)
IP rating	IP 67
Suitable greases	NLGI 0 - NLGI 3
Maximum operating pressure	700 bar (10 000 psi)
Maximum grease flow	1 000 cm ³ /min (34 fl. oz./min)
Thread connections	M10 × 1
Display	Lit LCD (4 digits / 9 mm)
Accuracy	±3 % from 0 - 300 bar ±5 % from 300 - 700 bar
Selectable units	cm ³ , g, fl. oz. or oz.
Display lamp auto switch off	15 seconds after last pulse
Low battery	Indication on display
Battery type	1.5 V LR1 (2×) Alkaline
Unit auto switch off	Programmable

LAGG 400B (page 32)

Designation	Description
LAGG 400B	Battery driven grease gun (with 230 V charger)
LAGG 400B/US	Battery driven grease gun (with 110 V charger)
Maximum operating pressure	400 bar (5 800 psi)
Min. burst pressure pump	800 bar (11 600 psi)
Grease nozzle	4 jaws (suitable for nipples according to DIN 71412)
Operating temperature range	-15 to 50 °C (5 to 120 °F)
Grease NLGI	NLGI 000 to NLGI 2
Weight/dimensions:	
Dimensions of grease gun including battery (L × H × D)	410 × 230 × 80 mm (16.2 × 9 × 3.2 in)
Weight of grease gun (including battery)	3,1 kg (6.8 lbs)
Dimensions of carrying case (W × D × H)	480 × 390 × 130 mm (18.9 × 15.3 × 5.1 in)
Total weight (including case)	5,4 kg (11.9 lbs)

PF-VPBM (page 33)

Designation	PF-VPBM
Lubricant	Grease up to NLGI grade 2
Reservoir capacity	450 cm ³ in 400 g cartridge G or W DIN 1284
Temperature range	-25 to 80 °C (-13 to 176 °F)
Mounting position	Any position
Delivery rate	2 cm ³ per stroke
Maximum back pressure	400 bar



Automatic lubricators

SKF SYSTEM 24 Single point automatic lubricators	
LAGD 125 and 60.....	38
LAGE 125 and 250.....	40
Re-lubrication Calculation Program DialSet 4.0	43
SKF Compact Greaser for Linear Guides	44
SKF MultiPoint Lubricator LAGD 400.....	46
Oil Leveller LAHD 500 and LAHD 1000	47
SKF MultiPoint Lubricator LAGD 1000.....	48
Technical data.....	49

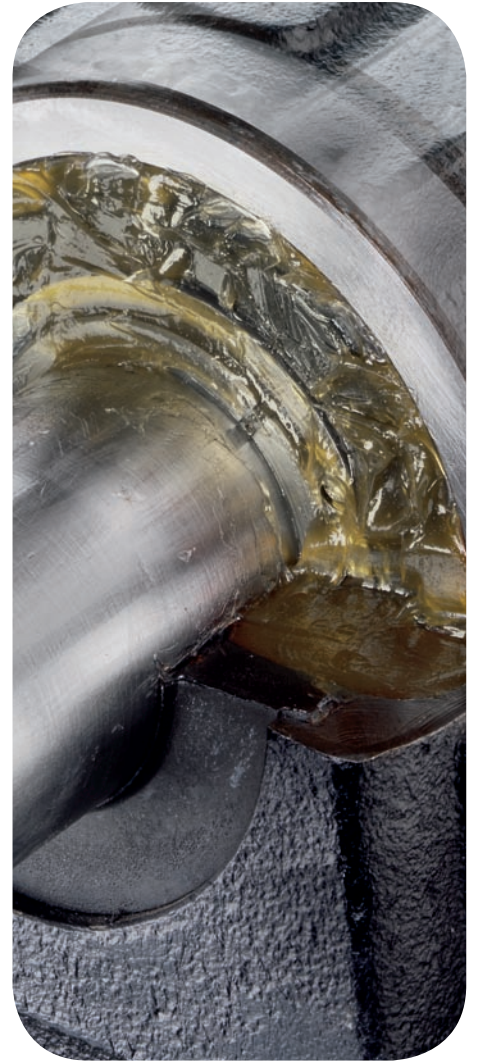

SKF SYSTEM 24

Single point automatic lubricator LAGD 60 and LAGD 125

Reliable, cost effective automatic single point lubricator

The LAGD series of the SKF SYSTEM 24 family are automatic gas driven single point lubricators suitable for many applications. The units are supplied ready-to-use straight from the box and filled with a wide range of high quality SKF lubricants. Tool-free activation and time-setting allows easy and accurate adjustment of lubrication flow.

- Gas driven lubricator is reliable in operation and flexible in application
- Available in two sizes: 125 ml (LAGD 125) and 60 ml (LAGD 60) to suit most bearing lubrication applications
- Compact size, permits installation in restricted areas.
- Available filled with various high quality SKF greases and oils, to suit a wide range of bearing applications
- Flexible time setting period ranging between 1 and 12 months
- Ingress protection to IP 68 level allows the lubricator to be used in most dusty and wet environments
- Wide operating temperature range to suit many applications
- High reliability and dispense rate accuracy helps facilitate predetermined replacement date
- Dispense rate setting is a simple part of the installation process and can be temporarily deactivated
- Transparent lubricant container allows visual inspection of dispense rate
- Intrinsic safety rating: ATEX approved for zone 0
- Wide range of accessories is available
- SKF SYSTEM 24 LAGD series is fully featured in SKF DialSet 4.0



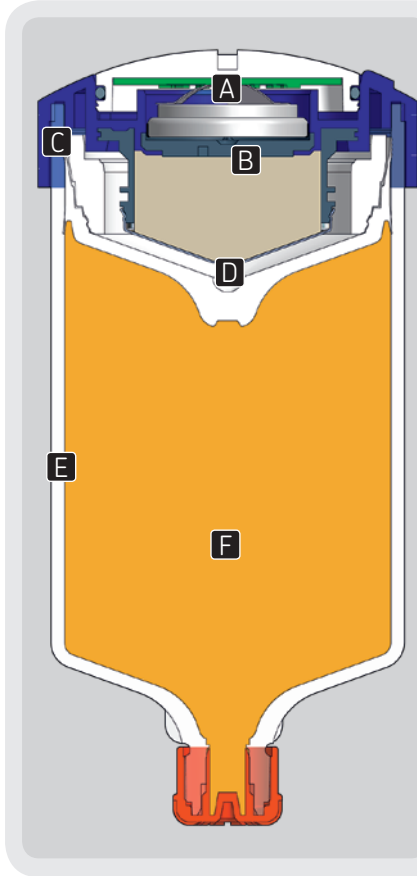

- A Time setting slot**
Allows easy installation and accurate adjustment of lubrication flow
- B Gas cell**
Generates pressure to enable lubricant dispensing
- C Easy-grip top-cover**
Facilitates easy and quick fitting
- D Piston**
Special piston shape helps ensure optimum emptying of lubricator
- E Lubricant container**
Transparent lubricant container allows visual inspection of dispense rate
- F SKF Lubricant**
Filled with a wide range of high quality SKF lubricants

Ordering details

Designation

LAGD 60/WA2
LAGD 125/WA2
LAGD 125/EM2
LAGD 125/GB2
LAGD 125/HB2
LAGD 125/HP2
LAGD 125/WM2
LAGD 125/FFP2 **

Description

60 ml (2.03 fl. oz. US) unit filled with LGWA 2 grease (multi-purpose EP type)
125 ml (4.25 fl. oz. US) unit filled with LGWA 2 grease (multi-purpose EP type)
125 ml (4.25 fl. oz. US) unit filled with LGEM 2 grease (high loads, slow rotations)
125 ml (4.25 fl. oz. US) unit filled with LGGB 2 grease (biodegradable)
125 ml (4.25 fl. oz. US) unit filled with LGHB 2 grease (high temperature, loads, plain bearing)
125 ml (4.25 fl. oz. US) unit filled with LGHP 2 grease (high performance polyurea)
125 ml (4.25 fl. oz. US) unit filled with LGWM 2 grease (high load, wide temperature)
125 ml (4.25 fl. oz. US) unit filled with LGFP 2 grease (food processing industry)

LAGD 60/HMT68 *
LAGD 125/HMT68 *
LAGD 125/HHT26 *
LAGD 125/FHF15 */**
LAGD 125/FU */**

60 ml (2.03 fl. oz. US) unit filled with LHMT 68 oil (medium temperature)
125 ml (4.25 fl. oz. US) unit filled with LHMT 68 oil (medium temperature)
125 ml (4.25 fl. oz. US) unit filled with LHHT 265 oil (high temperature)
125 ml (4.25 fl. oz. US) unit filled with LHFP 150 oil (food compatible, NSF H1 approved)
125 ml (4.25 fl. oz. US) empty unit suitable for oil filling only

* Includes non-return valve
** Not available in USA and Canada

SKF SYSTEM 24

Single point automatic lubricators LAGE 125 and 250

Reliable, reusable lubricator system meets many needs

The LAGE series of the SKF SYSTEM 24 family are single point electro mechanical driven automatic lubricator systems. Suitable for a wide range of applications and operating conditions, the units are reliable and flexible in operation.

Supplied ready to use straight from the box and ease of installation make the units a perfect compliment to the comprehensive range of SKF automatic lubricators.

- Electro mechanical driven makes the unit high reliable in operation
- Available in two sizes: 122 ml (LAGE 125) and 250 ml (LAGE 250) to suit most bearing lubrication applications
- Remote mounting up to 3 meters (10 ft) for grease filled units and 5 meters (15 ft) for oil filled units allows lubrication of bearings in areas with high ambient temperatures, excessive vibration or hazardous environments
- Available filled with various high quality SKF greases and oils, to suit a wide range of bearing applications
- Refill sets consisting of a canister filled with SKF grease or oil and a battery pack help ensure reliable lubricator operation
- Flexible user adjustable dispense settings of 1, 3, 6, 9, or 12 months for use in many different applications
- Ingress protection to 65 IP level allows the lubricator to be used in many dusty and wet environments
- Temperature independent dispense rate, suitable for use in applications with changing temperatures
- Unlike gas powered units, a maximum discharge pressure of 6 bar can be achieved over the whole lubricant dispensing period
- Easy activation using a clearly marked dial helps minimize setting errors
- Transparent lubricant container allows visual inspection of dispense rate, while electro mechanical functions are indicated by simple red-green LED indicators
- Intrinsic safety rating: UL listed
- Wide range of accessories is available
- SKF SYSTEM 24 LAGE series is fully featured in SKF DialSet 4.0



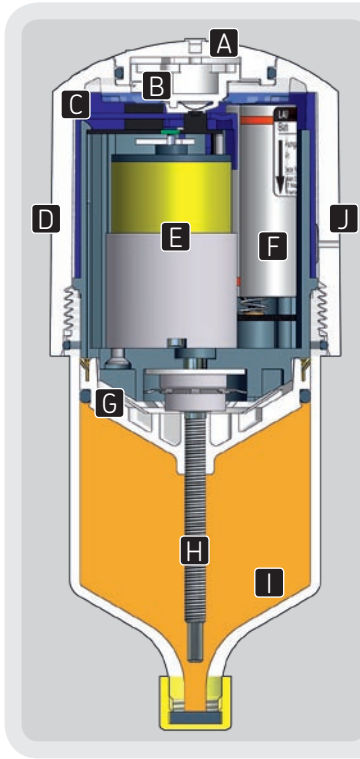

A B On/off knob and time setting dial

Enables easy activation and dial setting

C LED status indicators

Helps verify operating status

D Drive cover

Easily removable; seals and helps prevent ingress of dirt and moisture

E Electric motor and gearbox

Helps enable constant discharge pressure

F Battery pack

G Piston

Special piston shape helps ensure optimum emptying of lubricator

H Spindle

Rotates to drive piston, enabling lubricant to be dispensed

I Lubricant canister

Filled with high quality SKF lubricant

J Anti-vacuum membrane

Helps prevent vacuum forming



Ordering details

Designation		Lubricant	Description	Product		
Greases						
LAGE 125/WA2	LAGE 250/WA2,	LGWA 2	Multi-purpose EP type grease	Complete unit	125 ml	250 ml
LGWA 2/EML125	LGWA 2/EML250			Refill set	125 ml	250 ml
LAGE 125/EM2	LAGE 250/EM2	LGEM 2	High loads, slow rotations	Complete unit	125 ml	250 ml
LGEM 2/EML125	LGEM 2/EML250			Refill set	125 ml	250 ml
LAGE 125/HB2	LAGE 250/HB2	LGHB 2	High temperature, loads, plain bearing	Complete unit	125 ml	250 ml
LGHB 2/EML125	LGHB 2/EML250			Refill set	125 ml	250 ml
LAGE 125/HP2	LAGE 250/HP2	LGHP 2	High performance polyurea	Complete unit	125 ml	250 ml
LGHP 2/EML12	LGHP 2/EML250			Refill set	125 ml	250 ml
LAGE 125/WM2	LAGE 250/WM2	LGWM 2	High load, wide temperature	Complete unit	125 ml	250 ml
LGWM 2/EML125	LGWM 2/EML250			Refill set	125 ml	250 ml
LAGE 125/FP2	LAGE 250/FP2	LGFP 2	Food processing industry	Complete unit	125 ml	250 ml
LGFP 2/EML125	LGFP 2/EML250			Refill set	125 ml	250 ml
Oils						
LAGE 125/HMT68	LAGE 250/HMT68	LHMT 68	Medium temperature oil	Complete unit	125 ml	250 ml
LHMT 68/EML125	LHMT 68/EML250			Refill set	125 ml	250 ml
LAGE 125/HHT26	LAGE 250/HHT26	LHHT 265	High temperature oil	Complete unit	125 ml	250 ml
LHHT 265/EML12	LHHT 265/EML25			Refill set	125 ml	250 ml
LAGE 125/HFP15	LAGE 250/HFP15	LHFP 150	Food compatible, NSF H1 approved oil	Complete unit	125 ml	250 ml
LHFP 150/EML12	LHFP 150/EML25			Refill set	125 ml	250 ml

Automatic lubricators

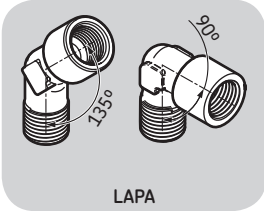

LAPA

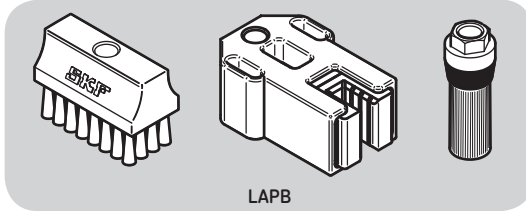

LAPB

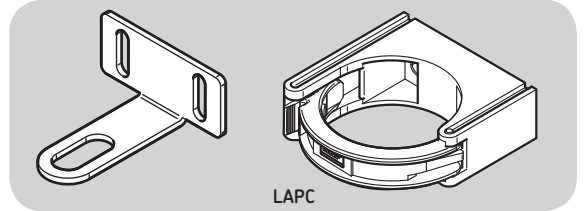

LAPC

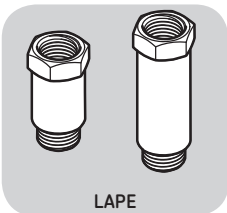

LAPE

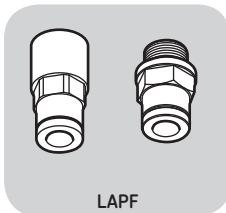

LAPF



LAPG

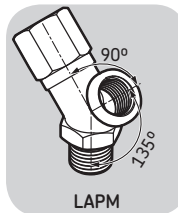

LAPM

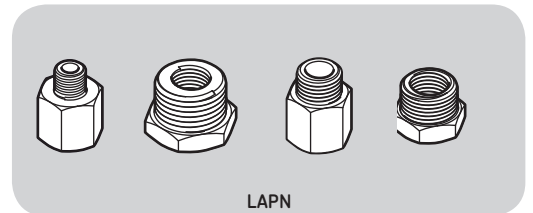

LAPN

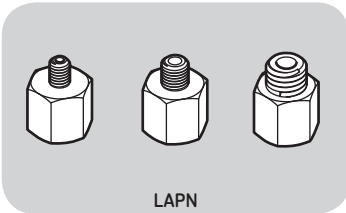

LAPN

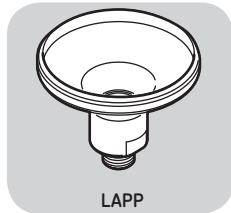

LAPP

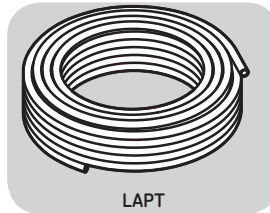

LAPT

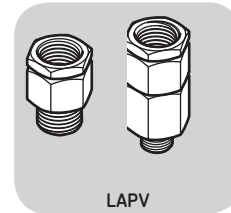

LAPV



LAGE 1-BAT

Accessories ordering details

Designation	Description	Designation	Description
LAPA 45	Angle connection 45°	LAPN 1/8	Nipple G 1/4 - G 1/8
LAPA 90	Angle connection 90°	LAPN 1/2	Nipple G 1/4 - G 1/2
LAPB 3x4E1 *	Brush 30 × 40 mm	LAPN 1/4	Nipple G 1/4 - G 1/4
LAPB 3x7E1 *	Brush 30 × 60 mm	LAPN 1/4UNF	Nipple G 1/4 - 1/4 UNF
LAPB 3x10E1 *	Brush 30 × 100 mm	LAPN 3/8	Nipple G 1/4 - G 3/8
LAPB 5-16E *	Elevator brush, 5 - 16 mm gap	LAPN 6	Nipple G 1/4 - M6
LAPB D2 *	Brush round Ø 20 mm	LAPN 8	Nipple G 1/4 - M8
LAPC 13	Bracket	LAPN 8x1	Nipple G 1/4 - M8 × 1
LAPC 50 **	Clamp	LAPN 10	Nipple G 1/4 - M10
LAPC 63 ***	Clamp	LAPN 10x1	Nipple G 1/4 - M10 × 1
LAPE 35	Extension 35 mm	LAPN 12	Nipple G 1/4 - M12
LAPE 50	Extension 50 mm	LAPN 12x1.5	Nipple G 1/4 - M12 × 1,5
LAPF F1/4	Tube connection female G 1/4	LAPP 2E **	Protection base
LAPF M1/4	Tube connection male G 1/4	LAPP 3E **	Protection cover
LAPF M1/8	Tube connection male G 1/8	LAPP 63 ***	Support flange
LAPF M3/8	Tube connection male G 3/8	LAPP 63V ***	Support flange with non-return valve
LAPG 1/4	Grease nipple G 1/4	LAPT 1000	Flexible tube, 1 000 mm long, 8 × 6 mm
LAPM 2	Y-connection	LAPT 5000 ***	Flexible tube, 5 000 mm long, 8 × 6 mm
LAPM 4 **	Manifold (4 to 1)	LAPV 1/4	Non return valve G 1/4
		LAPV 1/8	Non return valve G 1/8
		LAGE 1-BAT ***	Battery pack

* Suitable for use with oil filled SYSTEM 24 LAGD and LAGE units only
 ** Suitable for use with LAGD 60 and LAGD 125 SYSTEM 24 only
 *** Suitable for use with LAGE 125 and LAGE 250 SYSTEM 24 only

Relubrication calculation program DialSet 4.0

Accurate calculation of relubrication intervals

DialSet is a calculation program, which easily calculates the correct relubrication intervals settings. After selecting the criteria and grease relevant to your application, the program provides you with the correct settings for your SKF automatic lubricators.

- Selecting the operating conditions of your application, vertical shaft, outer ring rotation and shock loads, allows accurate calculation of the relubrication intervals
- Calculations are based on SKF lubrication theories
- Calculated lubrication interval depends on the properties of the selected grease, minimizing the risk of under- or over-lubrication and optimizing grease consumption
- Calculations are based on SKF automatic lubrication systems grease dispense rates, allowing the recommendation of the correct lubricator setting
- Recommended grease quantity depends on the grease replenishment position; side or W33* for optimum grease consumption
- Includes a complete list of the SKF SYSTEM 24 family accessories

DialSet 4.0 on CD-ROM

DialSet 4.0 is available on CD-ROM with calculation in 10 languages: English, French, German, Italian, Spanish, Swedish, Portuguese, Russian, Chinese, Thai and Japanese. The program is suitable for PC's working with MS Windows 98 or later. This CD-ROM can be ordered from SKF under designation MP3506.

DialSet 4.0 online

In addition to the downloadable PDA/PPC and the CD-ROM versions, SKF also offers you DialSet 4.0 online in English language. The program is available at www.skf.com. After filling in your application's conditions, calculations are made online and the program provides you with a printable relubrication interval recommendation.

DialSet 4.0 for PDA/PPC

If you own a PDA or a PPC, you can now calculate the correct relubrication intervals on-site. From www.mapro.skf.com you can now download, free-of-charge, the PDA/PPC version of SKF's relubrication calculation program DialSet 4.0 in English language.

* Some types of bearings have an annular groove and three holes in the outer ring intended to facilitate the lubricant to reach directly the load zone. This groove is identified with the suffix "W33". When the lubricant is supplied via this groove, the quantity required is much less than when it is fed from the side of the bearing. DialSet takes this into account and recalculates the required quantities.

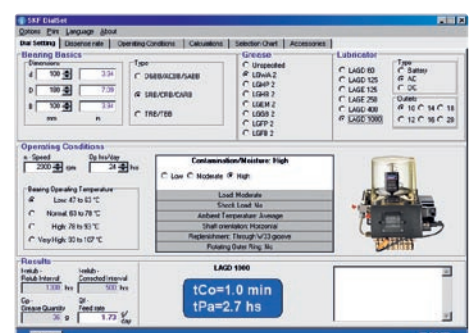
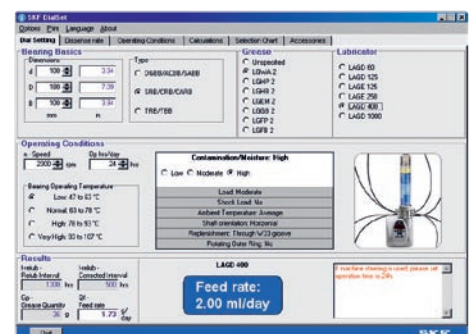
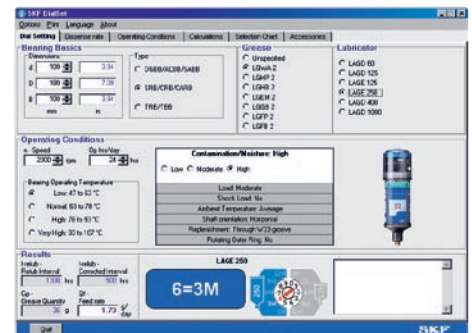
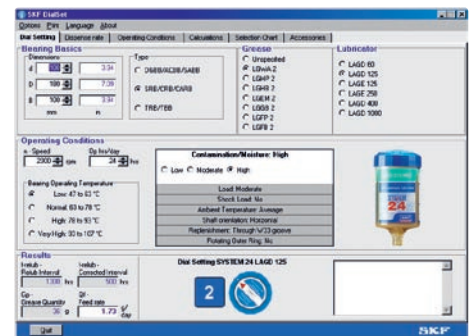

SKF Compact Greaser for Linear Guides and Robots

An excellent alternative for the lubrication of linear guides, robots and rolling bearings

Compact, automatic, dependable:

- Ideal alternative when no centralized lubrication system is available
- Dependable protection against deficient lubrication
- As many as five lube points are automatically supplied with lubricant
- Low maintenance and operating costs
- Also suitable for the lubrication of high-speed spindle bearings
- Up to 5 lubricant outlet ports
- 3 different metered volumes (15 mm³ standard)
- Suitable for grease, NLGI grades 000 to 2



Exact metering of lubricant quantities resulting in an economic and ecological payoff

The SKF Compact Greaser is the ideal alternative when it comes to the lubrication of linear guides, robots and rolling bearings on machinery and equipment if no central lubrication exists. Compared with simple lubricating equipment or manual lubrication, as is often the case in practice, the SKF Compact Greaser provides effective and lasting protection against deficient lubrication. The lubricator automatically supplies up to five lube points with lubricant, for a dependable operation of guides and/or bearings practically for their entire life cycle.

The SKF Compact Greaser offers significant benefits from an economical and ecological point of view. Low maintenance and operating costs are combined with variable lube cycles and exact metering of the lubricant quantities required.

Thanks to its low metering volumes the SKF Compact Greaser is also used with appropriate grease for the lubrication of spindle bearings.

Simple installation and connection to the machine's control system

Thanks to its small dimensions and low weight the SKF Compact Greaser weighs only 480 grams with a full cartridge – the lubricator is easy to install, even in cramped and complicated conditions. Its maximum power consumption amounts to 24 W, so the SKF Compact Greaser – like a solenoid valve – can be operated directly by the SPC, namely without a separate power pack or additional circuit breaker. This is where it reveals its superiority over simple lubricators that are not connected to the machine's control system and thus go on lubricating even during operating breaks. That leads to higher lubrication costs, unnecessary stress on the environment and damage to bearing seals.

The SKF Compact Greaser is designed for NLGI grade 000 to 2 grease and permits metering rates of 10, 15 or 20 mm³ per stroke. The number of outlet ports and the metering rates are flexible and can be specified when an order is placed, thus making it possible to find a customized lubrication solution, see the following table. The grease supply will suffice for up to 5 years, depending on the type of grease and its consumption. A bayonet lock makes it easy to replace the lubricator's grease cartridge.

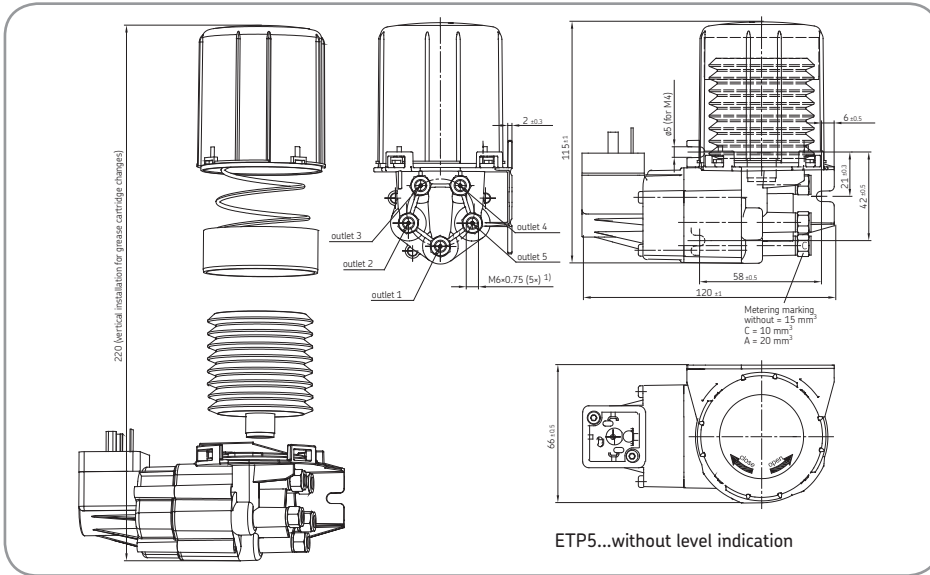

Order No.

Design	Number of lubrication points	Level- and stroke indication	Metering volume	Filling	Voltage key
<p>ETP</p> <p>Electro-thermic Pump</p>	<p>□</p> <p>2 = 2-digit: 1/3 3 = 3-digit: 1/3/4 4 = 4-digit: 1/2/3/4 5 = 5-digit: 1/2/3/4/5</p>	<p>□ □</p> <p>WZ = Indication for level- and stroke</p> <p>optionally</p>	<p>1 2 3 4 5</p> <p>□ □ □ □ □</p> <p>A = 20 mm³/stroke B = 15 mm³/stroke C = 10 mm³/stroke X = closed</p>	<p>□ □</p> <p>B = LGMT 2 rolling bearing grease C = LGGB 2 biodegradable grease D = LGFP 2 food-compatible bearing grease Z = Grease on customer request</p>	<p>□ □ □ □</p> <p>+ 9 2 4</p> <p>+924 = 24 V DC</p>
<p>FK008</p> <p>Grease cartridge (two pieces)</p>				<p>□ □</p> <p>B = LGMT 2 rolling bearing grease C = LGGB 2 biodegradable grease D = LGFP 2 food-compatible bearing grease Z = Grease on customer request</p>	

Order examples: ETP4-BBCBX-B+924 (Pump 4-digit, metering 15 mm³/stroke, 15 mm³/stroke, 10 mm³/stroke, 15 mm³/stroke, 1 outlet closed, filling with LGMT 2 rolling bearing grease, operating voltage 24 V DC)

FK008-B (Grease cartridge, 80 cm³, filling with LGMT 2 rolling bearing grease)



For additional information please refer to our brochure No. 1-0988-EN

Online available at www.skf.com/lubrication

Accessories

Order No

995-001-197+BF5

402-612

402-611

402-603

Description

PA tube, 1.5 m with socket union on one side, filled with grease

Socket union

Tapered sleeve

Reinforced socket

SKF MultiPoint Lubricator LAGD 400

Multiple grease lubrication points made easy

The lubrication of bearings with the correct type and quantity of grease is essential for trouble-free operation. Research has shown that 36% of all bearings fail prematurely due to incorrect lubrication. Especially for installations with multiple lubrication points, this can be a time-consuming and costly process.

SKF MultiPoint automatic lubricator is a user-friendly and cost-effective lubrication solution for multiple grease lubrication points. Its compact design, combined with electronically controlled accuracy, makes it an excellent solution for longer bearing life and increased uptime of your machinery.

- Do-it-yourself centralized lubrication system
- Up to 8 feed lines
- Easy-to-use
- DialSet 4.0 included:
SKF's relubrication calculation program allows accurate calculation of the correct relubrication intervals
- Long feed lines
(maximum up to 5 m / 16 ft)
- Electronic setting and read-out of control parameters
- Alarm function for blocked feed lines and empty cartridge
- Automatic start/stop function if the lubricator is connected to the central control unit of the machine
- High-pressure capability (40 bar / 600 psi)
- Tested and approved with all SKF greases
- Uses standard SKF grease cartridges (420 ml)
- Ready for use, all accessories included



Oil Levellers LAHD 500 and LAHD 1000

Automatic adjustment for optimal oil lubrication level

SKF oil levellers, LAHD 500 and LAHD 1000, are designed for automatic adjustment of the optimal oil lubrication level within a bearing housing, gear box, crank case or similar oil bath lubrication application. Not usually possible, SKF oil levellers allow you to effectively adjust the correct oil level during running conditions, optimizing machine performance and increasing the service life of the applications. Furthermore, they automatically compensate for oil leakage and offer the possibility of visual inspection of the oil level.

How it works

The SKF oil leveller consists of two communicating oil reservoirs. The lower reservoir is in direct contact with the application and hence its oil level is the same as the oil level inside the application.

Through a ventilation hole, the lower reservoir is also in direct contact with the ambient air. The upper reservoir is an airtight container storing replacement oil. Through its extended neck, which dips into the oil of the lower reservoir, the two reservoirs are in direct contact with each other. However, oil can only flow from the upper to the lower reservoir once the oil level in the lower reservoir goes below the pre-set level, allowing air to flow through the extended neck to the upper reservoir.

- Optimally maintained oil level provides adequate lubrication
- Easy visual inspection
- Extended relubrication intervals
- LAHD 1000 compensates for evaporation losses of up to 1 liter of lubricating oil
- Oil must be refilled manually



SKF MultiPoint Lubricator LAGD 1000

Centralized lubrication for up to 20 lubrication points

The SKF MultiPoint automatic lubricator LAGD 1000 is a reliable centralized lubrication system offering lubrication solutions for bearings and machinery. The LAGD 1000 uses a high-pressure pump and a progressive feeder for lubricating from 6 to 20 lubrication points. Supplied as a complete ready-to-use kit, all accessories required are included in the box.

- Suitable for greases from NLGI 000 to NLGI 2, offers high flexibility in types of lubricants that can be used
- Sturdy, robust design with IP65 rating, suitable for most industrial environments
- Transparent reservoir, allows visual monitoring of lubricant level
- Progressive distributor so that exactly the same amount of grease reaches each lubrication point
- 1 liter (33.8 fl. oz.) refillable grease container, increases intervals between refilling
- Extensive programming options, allowing flexibility to suit most applications
- Empty container alarm, helps reduce the risks associated with lack of lubrication
- Wide temperature range, helps meet a variety of tough operating conditions year round
- Timer setting:
Working time 1 ... 99 min.
Pause time 1 ... 99 h.
- Cycle switch function (not on battery version) notifies operator of blocked outlets so that proper action can be taken
- Battery powered version available, no need for external power source, can be used most anywhere



To order, specify power source and number of points.

Examples:

LAGD 1000 / B12	Battery powered
LAGD 1000 / DC12	24V DC
LAGD 1000 / AC12	110-240V AC

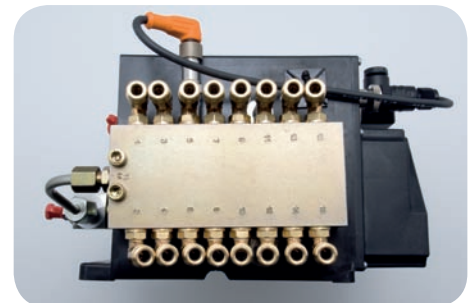

Technical data

LAGD 125 and 60 (page 38 - 39)

Grease capacity
LAGD 125 125 ml (4.25 fl. oz.)
LAGD 60 60 ml (2.03 fl. oz.)

Nominal emptying time Adjustable; 1 - 12 months
Ambient temperature range
 LAGD 60/.. and LAGD 125/..
 LAGD 125/F.. -20 to 60 °C (-5 to 140 °F)
 -20 to 55 °C (-5 to 131 °F)
Maximum operating pressure 5 bar (75 psi) (at start-up)
Drive mechanism Gas cell producing inert gas
Connection thread R 1/4
Maximum feed line length with:
 - grease 300 mm (11.8 in)
 - oil 1 500 mm (59.1 in)
Protection class IP 68

Intrinsically safe approval
 II 1 G Ex ia IIC T6
 II 1 D Ex iaD 20 T85°C
 I M1 Ex ia I

EC Type Examination Certificate
 LAGD 60/.. and LAGD 125/..
 LAGD 125/F.. Kema 04ATEX1275 X Issue 2
 Kema 07ATEX0132 X
Recommended storage temperature 20 °C (70 °F)
Storage life of lubricator 2 years
Weight
 LAGD 125 approx 200 g (7.1 oz)
 LAGD 60 approx 130 g (4.6 oz)
 Lubricant included

LAGE 125 and 250 (page 40 - 41)

Grease capacity
LAGE 125 122 ml (4,1 fl. oz US)
LAGE 250 250 ml (8,5 fl. oz US)

Emptying time User adjustable:
 1, 3, 6, 9 and 12 months
Ambient temperature range 0 °C (-10°C peak) to 50 °C
 (32 °F (14 °F peak) to 122 °F)
Maximum operating pressure 5 bar (75 psi)
Drive mechanism Electro mechanical
Connection thread R 1/4
Maximum feed line length with:
 - grease Up to 3 meters (10 ft) *
 - oil Up to 5 meters (16 ft)
LED status indicators operating, purging lubricant,
 empty, malfunction

UL certification
 UL listed
 T code 59°C - Category BAYZ - 92UM
 Lubricant dispensing equipment for use
 in hazardous locations
 Class I, Division II, Group A, B, C, D
 Class II, Division II, Group F & G
 Class III

Protection class assembled lubricator IP 65
Battery pack 4,5V 2,7 Ah - Alkaline manganese
Recommended storage temperature 20 °C (70 °F)
Storage life of lubricator 3 years **
 (2 years for LGFP 2 and Oils)
Total weight
 - LAGE 125 635 g (22.5 oz)
 - LAGE 250 800 g (28.2 oz)

* The maximum feed line length is dependent on ambient temperature, grease type and back pressure created by the application.

** Storage life is 3 years from production date, which is printed on the side of the canister.

The canister and battery pack may be used even at 12 months setting if activated 3 years from production date.

LAGD 400 (page 46)

Designation LAGD 400
Content 8-outlet lubricator
 20 m tubing
 Quick connectors for application side
 2 Y-connectors
 LGMT 2 / 0.4 grease cartridge
 SKF's DialSet program
Number of feed-lines 1 - 8
Maximum pressure 40 bar (600 psi)
Suitable grease NLGI 1, 2 and 3
Maximum length of feed lines 5 m (16 ft.)
Ambient temperature 0 - 50° C
 (32 - 120° F)
Drive mechanism Electro-mechanical

Volume 0,1 - 10 cm³/day
 (0.003 - 0.35 fl. oz./day)
 Per outlet: Approximately 0,6 - 65 g/
 week (0.02 - 2.3 oz./week)
Power 110-240V AC, 50-60Hz or 24V DC
Alarms Blocked feed lines, empty cartridge;
 Internal and external
External steering External relay steering
IP rating 54
Lubrication tubes 20 m (65 ft.), Nylon, 6 × 1,5 mm
 (1/4 × 0.06 in)
Connection thread G 1/4
Height 530 mm (21 in)

LAHD 500 and 1000 (page 47)

Designation	LAHD 500 / LAHD 1000
Boundary dimensions	
- LAHD 500	Ø 91 mm × 290 mm high (3.6 × 11.4 in)
- LAHD 1000	Ø 122 mm × 290 mm high (4.8 × 11.4 in)
Reservoir volume	
- LAHD 500	500 ml (17 fl. oz.)
- LAHD 1000	1 000 ml (34 fl. oz.)
Container material	Polycarbonate / aluminium
Allowed temperature range	- 20 to 125 °C (-4 to 255 °F)

Permissible humidity	0 - 100%
Length of connecting tube	600 mm (23.5 in)
Connection thread	G 1/2
Tube material	Polyurethane
O-ring material	NBR - 70 shore
Gaskets	NBR - 80 shore 6 pieces
Other material	Aluminum, bronze, stainless steel
Suitable oil types	Mineral and synthetic oils

Compact Greaser for Linear Guides and Robots (page 44 - 45)

Metering volume/outlet:	20 mm ³ /stroke = A 15 mm ³ /stroke = B (standard) 10 mm ³ /stroke = C
Number of outlets	2, 3, 4 or 5
Weight with full cartridge	0,48 kg
Max. back pressure	25 bar
Operating voltage	24 V DC
Contact time	7 min
Min. interval time	30 min
Power input	24 W
Starting current, max.	1 A

Operating temperature	+15 to +40 °C
Storage temperature	-25 to +60 °C
Type of enclosure acc. EN 60529:	IP55 with mounted connector
Lubricant	Grease, NLGI grades 000 to 2 (NLGI grade 3 on request)
Electrical connection:	
without monitoring	DIN EN 175301-803-A
with monitoring	M12×1
Level- and stroke indication:	
Max. switching current	0,5 A
Max. breaking capacity	10 VA

LAGD 1000 (page 48)

Designation	LAGD 1000/B	LAGD 1000/DC	LAGD 1000/AC
Maximum operating pressure	150 bar (2 175 psi)	150 bar (2 175 psi)	150 bar (2 175 psi)
Permissible operating temperature	-10 to 60 °C (14 to 140 °F)	-25 to 75 °C (-13 to 167 °F)	-25 to 60 °C (-13 to 140 °F)
Number of outlets	6 to 12	10 to 20	10 to 20
Maximum length of pipes	6 m (19.7 ft.)	6 m (19.7 ft.)	6 m (19.7 ft.)
Tubing	6 x 1,25 mm (0.05 in)	6 x 1,25 mm (0.05 in)	6 x 1,25 mm (0.05 in)
Output of pump element	1 cm ³ /min (0.061 in ³ /min)	2 cm ³ /min (0.122 in ³ /min)	2 cm ³ /min (0.122 in ³ /min)
Reservoir capacity	1 liter (33.8 fl. oz.)	1 liter (33.8 fl. oz.)	1 liter (33.8 fl. oz.)
Greases	Up to NLGI grade 2 Flow pressure < 300 mbar	Up to NLGI grade 2 Flow pressure < 700 mbar	Up to NLGI grade 2 Flow pressure < 700 mbar
Weight	5,8 kg (12.8 lbs.)	3,7 kg (8.2 lbs.)	4,8 kg (10.6 lbs.)
Protection class	IP65	IP65	IP65
Electrical specifications			
Power connection	n/a	DIN EN 175 301-803, Plug supplied	DIN EN 175 301-803, Plug supplied
Rated voltage	18V	24V DC	110 - 240V 50/60 Hz
Power consumption	16 Ah	-	-
Battery type	alkaline	-	-
Type power input at 20 °C (68 °F) and max. operating pressure		0,5 A	1.3A / 110V 0,4A / 230V
Battery pack life	12 months or 1 lubricator filling (whichever comes first) when installed by end of the battery pack expiration date.		



Centralized lubrication systems

SKF MonoFlex, single-line lubrication systems.....	52
Pump units, series MKU.....	53
Piston distributors.....	54
Piston distributors, group 340.....	55
Piston distributors, group 350	55
Piston distributors, group 390	56
SKF Dry Lubrication System for Conveyors	57
SKF LubriLean, minimal quantity lubrication systems.....	59
SKF Oil+Air, oil and air lubrication systems.....	62
SKF ProFlex, progressive lubrication systems.....	64
Progressive distributors for oil and grease.....	65
SKF MultiFlex, multiline lubrication systems.....	68
Pump units, series KFA and KFAS	69
Pump units, series KFG and KFGS	70
Pump units, series FF and FB.....	71
SKF DuoFlex, dual-line lubrication systems	72
Pump units, series SKF MultiLube	73
Pump units, series FK.....	74
Pump units, series FD3.....	75
Dual-line distributors	76
Dual-line accessories.....	77
SKF CircOil, circulating oil lubrication systems.....	78
Oil supply units.....	79
Fan and industrial application units: circulating oil.....	80
Single-circuit pump units	81
SKF Safeflow oil flowmeters	83
SKF Flowline Monitor – oil flow rate monitoring system.....	84
Flow limiters for oil.....	85
Flow monitors and sensors for oil	86
Level switches.....	88



This is a selection of standard lubrication solutions. For tailor-made solutions or a complete overview of SKF lubrication solutions please contact your SKF representative or visit us at www.skf.com/lubrication

SKF MonoFlex

Single-line lubrication systems designed for oil, semi-fluid grease and hard grease NLGI grades 000 to 2

SKF MonoFlex systems are mainly designed for small to medium-sized machines used in a range of industries, such as machine tool, printing, textile and construction.

Lubricant volumes ranging from 0,01 to 2,5 cc are dispensed to the individual lubrication point on each lube pulse. One piston metering valve per lubrication point makes sure the right amount of lubricant is delivered, regardless of any changes in viscosity or back pressure.

SKF MonoFlex systems are designed for pressures ranging from 16 to 315 bar and venting pressures from 2 to 70 bar. The parallel set-up of the single line metering valves enables a simple, and reliable system design and installation.

You can also look forward to scalable system planning, since SKF MonoFlex single-line lubrication systems feature a modular design.

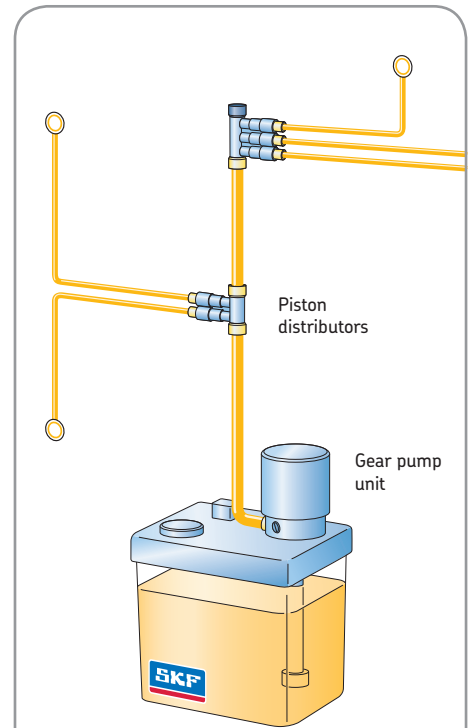

SKF MonoFlex – Single-line lubrication systems designed for oil, semifluid grease and hard grease. The system shown is for oil or semifluid grease.



Gear pump unit for oil



Manually operated piston pump



Single-line distributors for grease NLGI grade 2

SKF MonoFlex

Pump units, series MKU

Compact units for oil MKU -
0,1, 0,2 or 0,5 l/min

These MKU compact units were developed to supply intermittently operated single-line centralized lubrication systems with lubricant. The basic model contains a gear pump with drive motor as well as the set of valves required for pressure relief and limitation (safety valve). The lubricant reservoir material is metal or plastic. The units are controlled depending on their design:

- By hand (unit with a push button DK)
- By an external control system
- By a built-in electronic control and monitoring unit, timer or counter with adjustable interval and monitoring time
- By a built-in electronic control unit with adjustable interval time and fixed pump running time.

The control and monitoring unit is either a timer for time-dependent control or a counter for load-dependent control.

Design features

- Preliminary lubrication (lubrication after the supply voltage is turned on)
- Pump delay time
- Pressure dependent cut-off
- Monitoring of pressure build-up
- Monitoring of pump running time
- Possible monitoring elements:
 - Pressure switch (DS) monitors the automatic pressure build-up
 - Level indicator (WS)
 - Pressure gauge (MA) displays the pressure response in the main line
- Monitoring contact turns off machine if pressure fails to build up
- Indicator light, green shows that pump is running
- Indicator light, red indicates a fault if pressure fails to build up or if there is a low level of lubricant in the reservoir (only with built-in level indicator)



For additional information please refer to our brochure No. 1-1203-EN

Online available at:
www.skf.com/lubrication



MKU2-KW3-22003



MKU2-KW6-20003



MKU2-BW3-20003

Ordering details

Order no.	Delivery rate [l/min]	Reservoir capacity [l]	Reservoir material *	Components			
				DK	DS	WS	MA
MKU2-KW3-22003	0,2	3	K	•	•	•	•
MKU2-KW3-22013	0,2	3	K	•	•	•	•
MKU2-KW6-22003	0,2	6	K	•	•	•	•
MKU5-KW6-22003	0,5	6	K	•	•	•	•
MKU2-BW3-22003	0,2	3	B	•	•	•	•
MKU2-BW3-22013	0,2	3	B	•	•	•	•

* Reservoir material: K = plastic B = metal

• = components contained in the unit

DK = push button / DS = pressure switch / WS = level indicator / MA = pressure gauge

SKF MonoFlex

Piston distributors for single-line lubrication systems

Piston distributors meter out and distribute the oil delivered by an intermittently actuated pump. The quantities of oil for the individual lube points are determined by exchangeable metering nipples. The metered amount is indicated on the individual nipples. The amount needed to cover the total oil demand can then be further regulated via the lubricating frequency.

To meet the required quantities and comply with spatial constraints, it is possible to choose among four distributor groups that differ in terms of their metering ranges and sizes. The functional principle of the groups is the same but there are differences in design. Different distributor groups can be used in one installation.

Please note: Seal material: NBR.
In general, the operating conditions specified for the respective pump units will also apply to the distributors.

Limit values for the distributors:
Temperature range:
0 to + 80 °C (32 to 176 °F)
Effective oil viscosity:
5 to 2 500 mm²/s



Group 340 (0,01 - 0,16 cm³)



Group 350 (0,1 - 0,6 cm³)



Group 390 (0,2 - 1,5 cm³)

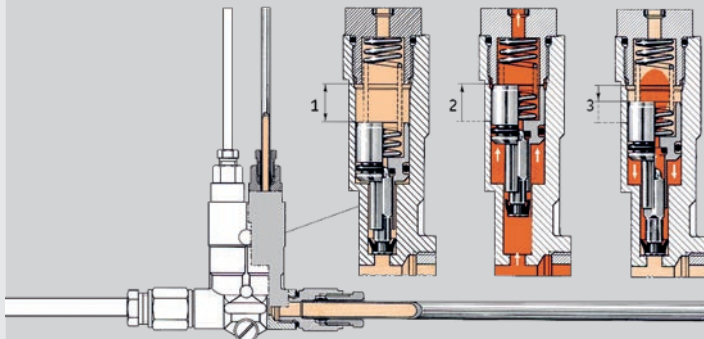

Function

1. The amount of oil intended for the lube point is stored in front of the piston in the distributor.
2. When the central lubrication pump starts delivering oil, the piston moves and the oil in front of it is fed to the lube point at a main line pressure of 12 - 45 bar.
3. After the pressure is relieved (≤ 1 bar) in the main line, the distributor's piston returns to its initial position and once again lets a certain quantity of oil flow into the space in front of it.

SKF MonoFlex

Piston distributors, group 340

0,01 - 0,16 cm³ (for oil)

To order:

The order no. has 9 places.

To complete the order no., supplement it with the order key to specify the desired metered quantities.

Ordering example:

Piston distributor, 5-port type,

345-4 metered with

(from left to right)

0,03 - 0,10 - 0,10 - 0,16 - 0,06 cm³

Order key:

2 4 4 5 3

Order no.:

345-424-453

Group 340-... distributors are intended for direct connection to a main line with a diameter of 6 mm (double tapered sleeve and socket union)

Please note:

The piston distributors comprising groups 340, 350 and 390 are only supplied complete with metering nipples.

Possible tubing connection:

M8 x 1 ports tapped for solderless

Ø4 tube connection.



Piston distributors*

Order no.	Number of lube points
342-4..-000	2
343-4..-.00	3
345-4..-...	5

* available only with metering nipples installed

Metering nipple with O-ring, exchangeable

Order no.	Related metered quantity [cm ³]	Order key	Marking on the metering nipple
Metering nipple not exchangeable			
	0,01	1	1
	0,02	6	2
995-994-103	0,03	2	3
995-994-106	0,06	3	6
995-994-110	0,10	4	10
995-994-116	0,16	5	16

Piston distributors, group 350

0,1 - 0,6 cm³ (for oil)

Ordering example:

Piston distributor, 3-port type,

353-0 00 metered with

(from left to right) 0,1 - 0,4 - 0,2 cm³

Order key:

4 6 5

Order no.:

353-046-500

Piston distributors*

Order no.	Number of lube points
351-0.0-000	1
352-0..-000	2
353-0..-.00	3
355-0..-...	5

* available only with metering nipples installed



Metering nipple with O-ring, exchangeable

Order no.	Related metered quantity [cm ³]	Order key	Marking on the metering nipple
352-010-K	0,1	4	0,1
352-020-K	0,2	5	0,2
352-040-K	0,4	6	0,4
352-060-K	0,6	7	0,6

SKF MonoFlex

Piston distributors, group 390

0,2 - 1,5 cm³ (for oil)

Order example:

Piston distributor, 3-port type,
393-0 . . - .00 metered with
(from left to right) 1,5 - 1,0 - 0,4 cm³

Order key:

9 8 6

Order no.:

393-098-600



Piston distributors*

Order no.	Number of lube points
391-0.0-000	1
392-0.-000	2
393-0.-.00	3

* available only with metering nipples installed

Metering nipple with O-ring, exchangeable

Order no.	Related metered quantity [cm ³]	Order key	Marking on the metering nipple
391-020-K	0,2	5	0,2
391-040-K	0,4	6	0,4
391-060-K	0,6	7	0,6
391-100-K	1,0	8	1,0
391-150-K	1,5	9	1,5



For additional information please refer to our brochure No. 1-5001-EN

Online available at
www.skf.com/lubrication

Example of group 350 distributors:

Secondary line connections for steel tubing:

Socket union

Double tapered sleeve

Metering nipple

Screw plug or adapter when main line is continued or threaded socket when connected to a further piston distributor

Secondary line connections for plastic tubing:

Socket union

Tapered ring

Reinforcing sleeve

Attention!

Only in the case of the piston distributors shown here is it permissible to close unneeded ports.

Ports on progressive feeders must not be closed!
Feeders would block!

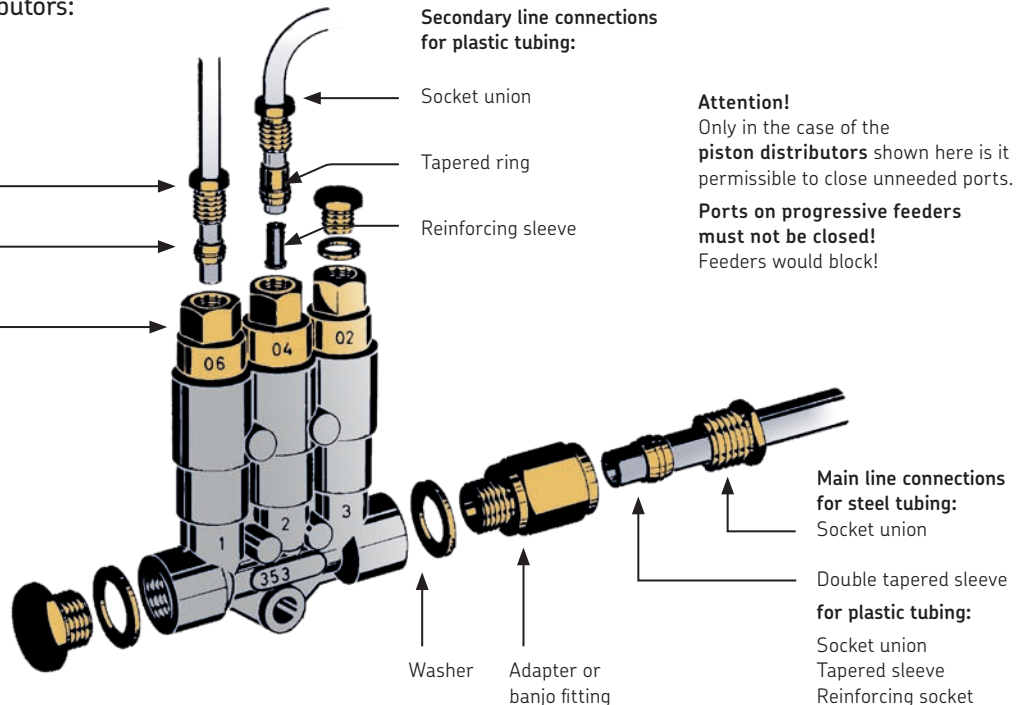

SKF Dry Lubrication System for Conveyors

Applications

The SKF Dry Lubrication System for Conveyors practically eliminates the use of water-soluble lubricants. Using special lubricants, these systems have been developed to lubricate belt conveyor surfaces, as well as the conveyor guides, for the transport of products on bottling and packaging plastic conveyors.

A metered volume of lubricant is applied to the belt surface by means of coating plates that contact the conveyor chain at the same time lubricant is directly injected into the conveyor guide with the same lubrication unit. The metered volume of lubricant is independent of any possible lubricant viscosity variation, the line length or the lube point number.

The SKF Dry Lubrication System is used on filling lines for beverage cartons, plastic bottles, and so on, in the following segments of the food industry:

- Milk and dairy plants
- Fruit juice, sauce and soup production
- Bottled water production
- Beverages (soda, beer, etc.)

And in many other fields such as:

- Cleaning products
- Cosmetics
- Pharmaceuticals

Features

- Better sliding of the products
- Reduced chain wear
- Safety and cleanliness
- Dry environment, no water
- Less metal corrosion
- No deterioration of the conveyed products in the holding area
- No friction noise or "stick-slip" effect
- No bacterial growth
- Complies with environmental standards
- Approved for use in food applications

Problems on line conveyors

Due to the speed difference between the filling machine and the packaging machine, or the failure of one of them, products slow down, fall and collect on the belt conveyor at the end of the line. At the same time guides are supporting the conveyor belt where there is continuous friction.

If the friction between the belt and the product is too high (without lubrication), package bottoms can be damaged, especially cartons. The belt then needs more power for moving, resulting in belt damage.

A lubrication system helps to keep a constant and sufficient friction coefficient. It can be adapted to any production line (conveyor belt type, carried products).

- Too much friction (insufficient sliding) results in:

- Possible deterioration of the products (especially cartons)
- More power consumption for the belt motion (engine over-current, extreme tension of the belt)
- Possible falling of the products when changing direction
- More wear on the belt surface and guides

- Where there is not enough friction, products slide too much and it is hard to carry them properly (they slow down or stop moving completely)



Disadvantages of the water + soap solution

Currently, some lubrication systems are based on a spraying network of water + soap. With these systems, it is not possible to precisely meter the quantity of lubricant sprayed on the belt (it is often higher than the real amount needed), and the use of water causes many problems:

- Bacteriological and organic growth
- High costs due to excessive water consumption and effluent treatment
- Foaming
- Corrosion
- Slippery floors
- Damaged packages

Dry lubrication

Dry lubrication systems have been especially designed for the lubrication of conveyor surfaces and guides with special lubricant. These systems replace classic wet lubrication systems due to the high performance of the lubricant: a PTFE based oil suitable for the food industry. When correctly metered, it leaves a dry sliding coat on the belt surface and/or its guides. The aim of the dry lubrication system is to deliver automatically and precisely the right quantity at the right friction point (belt surface or guides) from a central unit, which can feed many lubrication points.

Lubricant application principle

- **Lubrication of the conveyor belt surface**
Very small metered quantities of oil are delivered intermittently by a piston metering system into a number of coating plates that contact the conveyor chain. The coating plates deliver an oil film on the chain as long as the unit is actuated.
- **Lubrication of the guides**
The same metering system, connected to the same central unit, is used to directly inject a metered quantity of lubricant through a tube and connector fitted on the guides.

If you would like more information on SKF Dry Lubrication System for Conveyors, contact SKF or your local SKF distributor.



For additional information please refer to our brochure No. 1-4120-EN

Online available at
www.skf.com/lubrication

SKF Dry Lubrication System for Conveyors

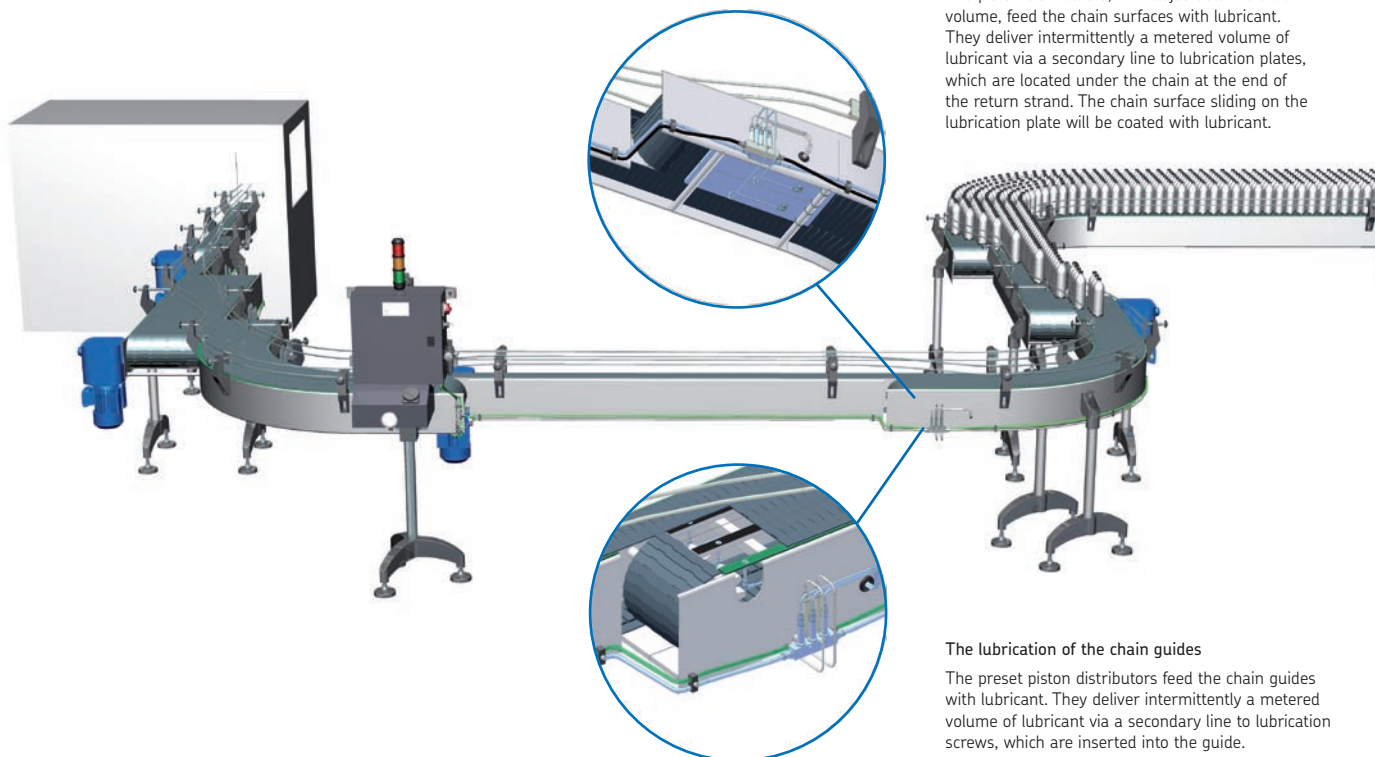

The lubrication of the chain surfaces

The piston distributors, with adjustable metered volume, feed the chain surfaces with lubricant. They deliver intermittently a metered volume of lubricant via a secondary line to lubrication plates, which are located under the chain at the end of the return strand. The chain surface sliding on the lubrication plate will be coated with lubricant.

The lubrication of the chain guides

The preset piston distributors feed the chain guides with lubricant. They deliver intermittently a metered volume of lubricant via a secondary line to lubrication screws, which are inserted into the guide.

SKF LubriLean

Minimal quantity lubrication systems

When it comes to machine tools, reliability, precision and efficiency are crucial. To help meet these demands, SKF has developed centralized, multi-point lubrication systems that help machines run more smoothly, while also extending the service life of linear guides and bearings. Applications of SKF LubriLean for machine tools includes milling, rolling, cutting, drilling, boring, forming among others.

Lubrication between the tool and workpiece is performed by an aerosol that is formed by oil droplets that are finely dispersed in an air stream. Minimal quantity lubrication (MQL) can be fed to the tool or workpiece in two different ways, internal or external.



SKF LubriLean VarioSuper



SKF LubriLean DigitalSuper

SKF LubriLean, internal MQL

With the internal lubrication method, compressed air or the aerosol is applied through the spindle, the tool holder and the tool directly at the point between tool and workpiece. SKF LubriLean VarioSuper and SKF LubriLean DigitalSuper 1 are examples of internal MQL system units that leading original equipment manufacturers install on machine tools for a reliable and productive operation.

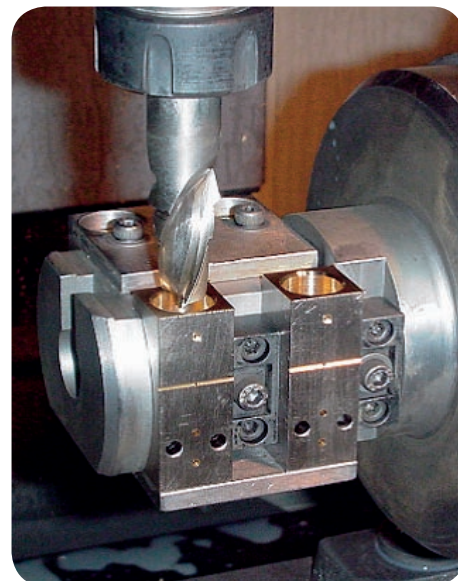

Internal MQL

External minimal quantity lubrication

SKF LubriLean, external MQL

A clean alternative for lubricant projection in minimal quantity

With external minimal quantity lubrication the aerosol is supplied to the lubrication point from the outside through nozzles. SKF LubriLean Basic, SKF LubriLean Smart and SKF VectoLub are examples of external MQL system units. With the right expertise, machine tools that are not supplied with a centralized lubrication system, can be upgraded with SKF LubriLean external minimal quantity lubrication technology.

SKF LubriLean external MQL system can be used in many areas:

- Machining: sawing, drilling, tapping, milling, bar turning, drawing, cutting, punching, stamping
- Car industry: motor oiling, components, assembling, lubrication of conveyor chain...
- Food industry: lubrication of conveyor, chain, of conditioning lines
- Aeronautical industry: drilling, assembling
- Printing industry: lubrication of cutting tools, of folding machine

Advantages

- Higher machining performance (higher speeds when cutting and parting)
- Better surface finish thanks to lower friction-induced temperature
- Long tool life, mainly when high-frequency machining is involved
- Exact adjustment of delivery rate saves lubricant
- The lubricant is consumed during the machining process. No residue is left on the work piece or chips. No disposal of lubricant residue, no de-greasing of parts and chips
- Greater safety and environmental hygiene at the workplace.
- No mist, clean air to breathe

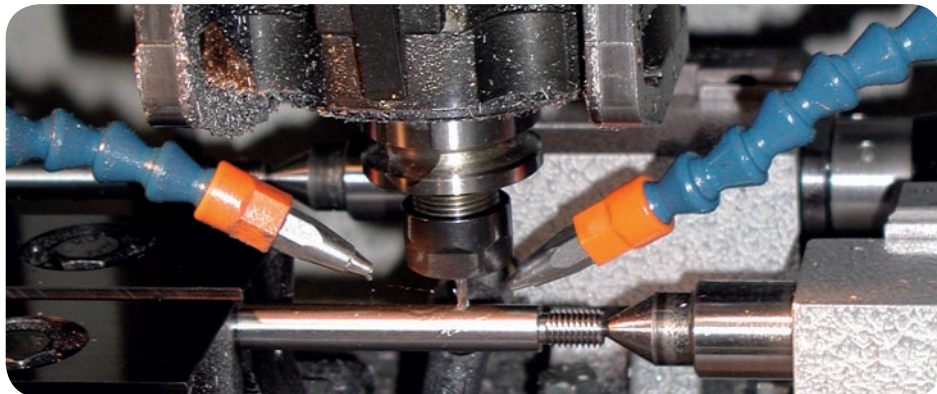

External MQL

A complete product range:

SKF VectoLub VTEC unit

Minimal quantity lubrication unit with up to 8 outlets

- **Modular:** It fits perfectly to the application of the client.
- **Upgradable:** It is possible to remove or to add at any time a module to the system.
- **Multipurpose:** A single system can lubricate different independent applications.

- **Reliable:** Every outlet can be independently controlled and monitored.



For additional information please refer to our brochure ref. 1-4401-EN

Online available at www.skf.com/lubrication



SKF LubriLean Basic and SKF LubriLean Smart

Applications include drilling, milling, broaching, tapping, thread forming

- Universal milling machines
- Applications with up to two (SKF LubriLean Smart) or eight (SKF LubriLean Basic) lube points
- Conventional machine tools can be easily retrofitted

- Simple adaptation
- No dripping nozzles after shutdown
- Large spray distances achievable (up to 300 mm)



For additional information please refer to our brochure No. 1-5102-EN

Online available at www.skf.com/lubrication



SKF VectoLub VE1B unit

Minimal quantity lubrication unit with up to 4 outlets

- **Economical:** An economical alternative to the VTEC system
- **Compact:** Compact system requiring few space. It can be installed closer to the application.

- **User friendly:** Only one control setting for all micropumps.
- **Kit:** The VE1B system can be sold in kit form (units, reservoir, hoses and nozzles)



For additional information please refer to our brochure No. 1-4403-EN

Online available at www.skf.com/lubrication



A complete accessories offer:

Lubricant reservoirs with capacities from 1 to 10 liters, with or without level monitoring

- Projection units with or without projection tube (articulated plastic or bendable copper tube)

- Nozzles with different jets: circular jet, fine circular jet, wide jet, annular jet and nozzles for special applications
- Coaxial tubes, 1 to 5 m, polyamide or reinforced tubes



For additional information please refer to our brochure No. 1-4402-EN

Online available at www.skf.com/lubrication



SKF Oil+Air

Oil and air lubrication systems

SKF Oil+Air lubrication systems are designed primarily for high speed bearings, chains and special applications in the steel industry. A pump, progressive feeder or single line distributor injects a small metered amount of oil into a mixing valve. The air flow is set to a minimum. The oil moves slowly to the lubrication point and provides the bearing or chain with a small, continuous stream of oil and air. This means that the bearing housing is under a slight overpressure, which keeps dirt away from the sensitive bearings. This concept creates no oil mist or oil fog, making it environmentally friendly as well. SKF Oil+Air lubrication systems can be tailor-made and apply leading oil-streak sensor technology.

Advantages:

Better machining performance due to better speed characteristics (up to some 2,200,000 mm · rpm in the case of rolling bearings).

Higher reliability due to clean bearings: continuous supply of fresh lubricant in the right amounts; system-related sealing air protects bearings from outside contamination.

Less lubricant:

As much as necessary, as little as possible – for more safety and environmental hygiene; metered quantities for each friction point to meet the precise need, but some 90% less consumption compared with oil-mist lubrication; no mist, clean air to breathe; no repack period compared with grease lubrication.

Applications:

Prominent applications are the lubrication of high-speed rolling bearings, of the kind used in machine tool spindles and the economical lubrication of closed gearboxes.

An oil and air system can be used to apply small quantities of lubricant in production processes involving textile fibres. (gripper lubrication)



SKF Oil+Air unit OLA04

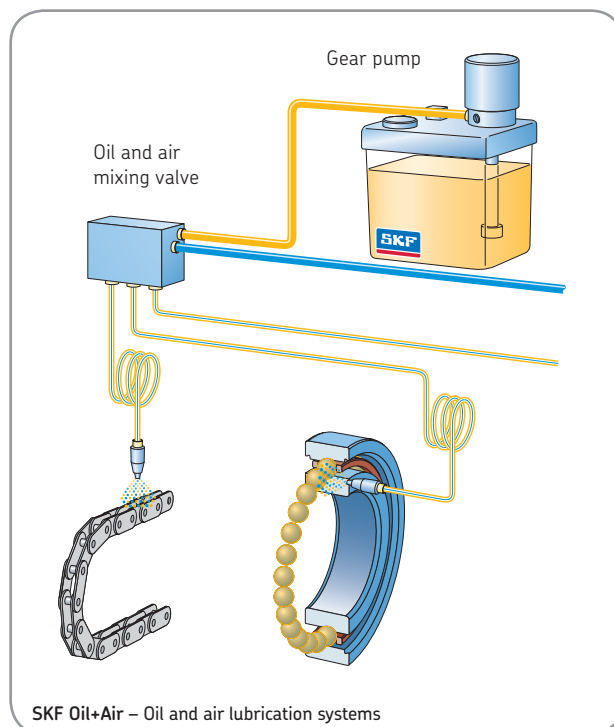

SKF Oil+Air – Oil and air lubrication systems

SKF Oil+Air units

Choice of equipment, examples

Choice of equipment, examples				
Order No.	Lube points	Unit	Mixing valve	Special features
OLA04-23001	4	MKU2-KW3-22001	MV204-20	integrated control unit IG38-30-I
OLA04-53002	4	MKL2-KW3-23041	MV204-20	integrated control unit IG54-20-S4-I
OLA04-03102	4	MKU2-KW3-20011	MV204-20	without control, 1 µm filling filter
OLA03-53301	3	MKL2-KW3-23041	MV203-20	integrated control unit IG54-20-S4-I, 5 µm air filter, 1 µm oil pressure filter
OLA16-01-S1	1	501-301-024	MV21	integrated control, KW1 5 µm air filter, 3 µm oil filter, GS300 flow sensor
OLA29-02	2	MFE5-KW3-2	MV32 342-422-000	installed in Rittal cubicle, 25 µm oil pressure filter, GS300 flow sensor
OLA31-03-S1	3	501-303-004	MV51	without control, KW1 5-port flow volume divider
OLA04-03101	4	MFE5-KW3-2-S12	MV204-20	without control, 3 µm oil pressure filter, min./max. pressure switch
OLA72-02	2	501-303-028	MV57.U1	pneumatic pulse generator 233-900-000
OLA01-52004	1	MKU1-KW2-20005+428	MV201-20	with control (switch cabinet), 5 µm filter, oil-streak sensor, helical coil



For additional information please refer to our brochure No. 1-5012-3-EN

Online available at
www.skf.com/lubrication

SKF ProFlex

Progressive lubrication systems designed for oil, semi-fluid grease and hard grease NLGI grades 000 to 2.

SKF ProFlex systems are designed for small and medium-sized machines. They are used, for example, in the printing industry, construction machines, industrial presses and wind turbines.

A feed pump or flow limiter supplies lubricant to the distributor that serves each outlet progressively, with a defined amount of lubricant. Each distributor outlet can also serve a secondary distributor that divides the amount into smaller portions for progressive delivery to their outlets. To control the system's function, only one metering piston has to be controlled on a frequency basis.

SKF ProFlex progressive lubrication systems are designed for up to 150 lubrication points with grease or oil. In combination with parallel flow limiters, they can serve up to 1 000 lubrication points or even more with oil. SKF ProFlex includes a wide range of progressive distributors based on a block, segmental or modular design with 2 to 20 outlets, flow rates of 0,01 cc to 6 000 cc/min. and system pressures as high as 300 bar.

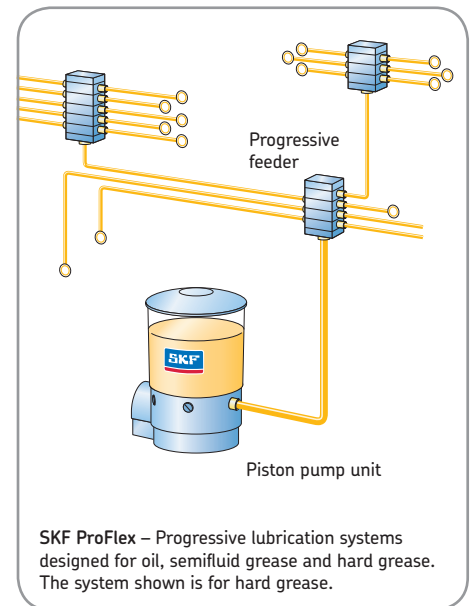
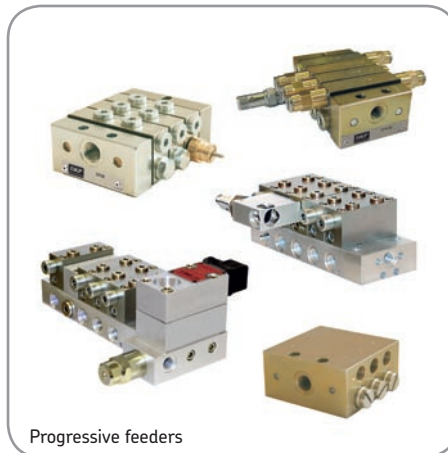

SKF ProFlex

Progressive distributors for oil and grease

Progressive distributors

Progressive distributors dispense an amount of lubricant delivered by a pump to several outlets while the feeder determines the volumetric ratio. The different output quantities within a feeder are achieved by the use of various piston diameters or the joining of two or more outlets. The indicated lubricant quantities result from the piston diameter and the travel of the piston.

Block distributor VPB

The block distributor is available with 3 to 10 pistons and serves, depending on the cross-porting arrangement, 2 to 20 lube points with oil or grease. The stroke volume per cycle is 0,2 cm³.

Attachments

- Optical cycle indicator
- 2 or 3 pin el. piston detector
- 2/2 directional solenoid valve
- External crossporting

Features

- Accurate lubricant distribution
- Outlet quantity from 2 to 20
- Central function monitoring with one simple indicator or el. piston detector
- Universally usable for oil (min. 12 mm²/s) and grease (max. NLGI grade 2)
- Economic and reliable
- Flexible system design with master and secondary feeders
- Max. 200 strokes/cycle per min.

Sectional distributor VPK and VP

The sectional distributors are also available with 3 to 10 pistons thus depending on the crossporting arrangements also designed for 2 to 20 lube points. The individual sections are available in different stroke volume sizes. Thus the output quantity can be fine tuned to the bearing requirements. The VP distributor is designed with built-in non return valves, a typical master feeder valve arrangement.

Attachments

- Optical cycle indicator
- 2 or 3 pin el. piston detector
- 2/2 or 4/2 directional solenoid valve for intermittent lubrication
- Flow limiter for oil, keeps the flow stable, independent of back pressure and viscosity fluctuations

 For additional information please refer to our brochures:

Leaflet No.	VP	1-3015-EN
	VPK	1-3016-EN
	VPB	1-3017-EN
	PSG 2	1-3013-EN
	PSG 3	1-3014-EN

Online available at
www.skf.com/lubrication

Modular distributor PSG

The modular distributors PSG covers also an outlet range of 2 to 20. The unique design with separate base plate allows an easy block configuration and servicing. The large internal porting arrangements allow high flow rates up to 2,5 l/min (PSG2) or 6 l/min (PSG3). This is important for reliable oil circulating systems. Eight different section sizes (PSG2) and several unique attachments offers you the most reliable, accurate and flexible distributor.

Attachments

- Optical cycle indicator
- 2 or 3 pin el. piston detector
- 2/2 or 4/2 directional solenoid valve for intermittent lubrication
- Flow limiter or flow regulator for oil keeps the flow stable, independent of back pressure and viscosity fluctuations
- Rotary gear indicators for oil
- External crossporting connectors



SKF ProFlex

Progressive distributor, selection diagram

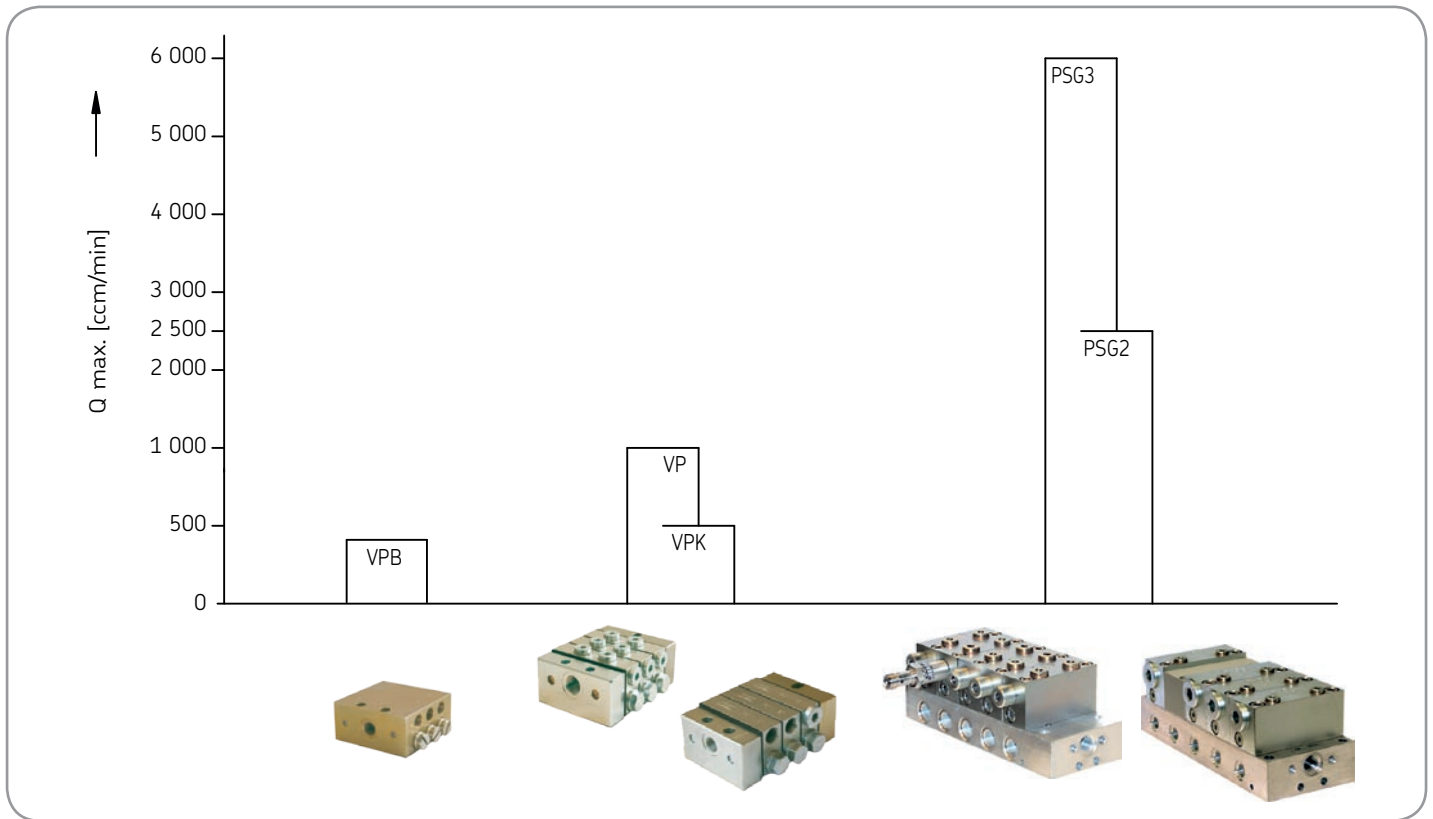

Available stroke volumes per cycle and outlet

VPB	VPK		VP		PSG 2 ¹⁾		PSG 3 ¹⁾	
Volume per cycle and outlet	Designation	Volume per cycle and outlet	Designation	Volume per cycle and outlet	Designation	Volume per cycle and outlet	Designation	Volume per cycle and outlet
	Type of sectional plate		Type of sectional plate		Type of segments		Type of segments	
0,2 cm ³	05T	0,05 cm ³						
	1T	0,10 cm ³	1T	0,10 cm ³	60	0,06 cm ³		
	2T	0,20 cm ³	2T	0,20 cm ³	120	0,12 cm ³		
	3T	0,30 cm ³	3T	0,30 cm ³	240	0,24 cm ³		
			4T	0,40 cm ³	360	0,36 cm ³		
			5T	0,50 cm ³	480	0,48 cm ³		
			6T	0,60 cm ³	600	0,60 cm ³		
	0.5S	0,10 cm ³			720	0,72 cm ³		
	1S	0,20 cm ³	1S	0,20 cm ³	840	0,84 cm ³		
	2S	0,40 cm ³	2S	0,40 cm ³			800	0,80 cm ³
	3S	0,60 cm ³	3S	0,60 cm ³			1 200	1,20 cm ³
			4S	0,80 cm ³			1 600	1,60 cm ³
			5S	1,90 cm ³			2 400	2,40 cm ³
			6S	1,20 cm ³			3 200	3,20 cm ³

¹⁾ Stroke volumes for twin versions. For single version, please double the stroke volume

SKF ProFlex

Order code for standard progressive distributors



For additional information please refer to our brochures:

feeder	Leaflet No.
VP	1-3015-EN
VPK	1-3016-EN
VPB	1-3017-EN
PSG 2	1-3013-EN
PSG 3	1-3014-EN

Online available at
www.skf.com/lubrication



VPBM/VPBG



VPKM/VPKM



VPM/VPG



PSG2

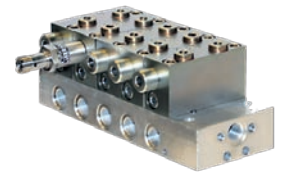

PSG3

Order Code for Standard distributors

Order Code	Inlet connections	Outlet	Pressure bar max.	VPKM 06 12/ZY/2R/
VPBM	M10x1	M10x1	300	
VPBG	G1/8"	G1/8"	300	
VPKM	M10x1	M10x1	300	
VPKG	G1/8"	G1/8"	300	
VPM	M14x1,5	M10x1	300	
VPG	G1/4"	G1/8"	300	
PSG2	G1/4"	G1/4"	200	
PSG2	9/16-18	9/16-18 UNF	200	
PSG3	G3/8"	G1/4"	200	
PSG3	G3/4-16	9/16-18 UNF	200	
Number of feeder sections				
03 = 3 sections				
04 = 4 sections				
10 = 10 sections				
Number of working outlets				
03 to 20				
Attachments				
00 = without,				
P2 = piston detector 2-Pin				
P3 = piston detector 3-Pin,				
ZY = cycle indicator				
Attachments, assembly position				
-1R = feeder, right hand side, 1. section				
-1L = feeder, left hand side, 1. section				
-2R = feeder, right hand side, 2. section				
-0R = feeder, right hand side, 10. section				
-0L = feeder, left hand side, 10. section				
Further information:				
Size of required feeder sections and crossporting arrangements				
Attachment				
- 2/2 or 4/2 way solenoid valves				
- Flow limiter or regulator				
- Rotary gear indicators				

SKF MultiFlex

Multiline lubrication systems designed for oil, semi-fluid grease and hard grease NLGI grades 000 to 3.

SKF MultiFlex systems are designed for automatic relubrication as well as small circulating oil systems on applications in the machine-tool industry, oil and gas, and heavy industry – just to name a few examples.

Multi-piston pumps supply the lubricant directly to the lube point without the use of extra metering valves. Each lubrication point thus has its own pumping element.

The system design is simple, accurate and reliable. SKF MultiFlex systems include a wide range of multi-outlet pumps from 1 to 32 outlets, and are able to withstand system pressures as high as 4 000 bar.

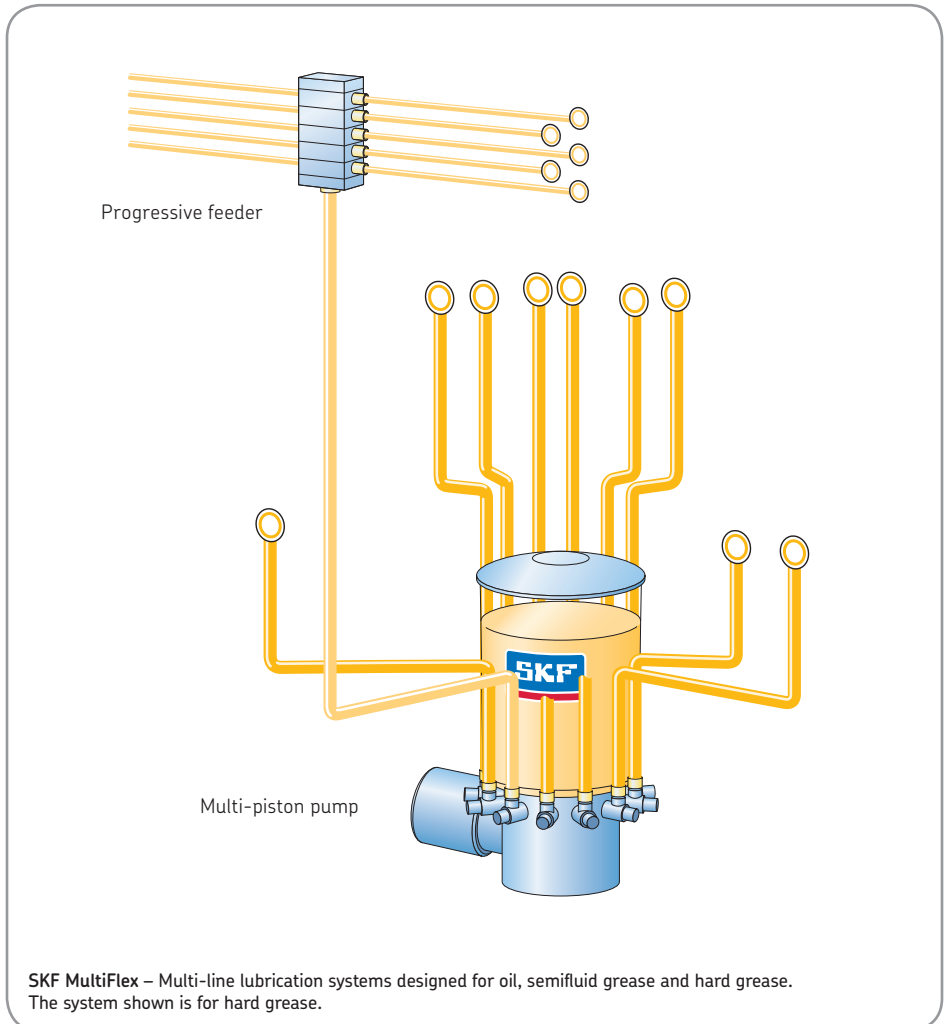

SKF MultiFlex

Pump units, series KFA and KFAS

Pumps belonging to the KFA(S) series come with a maximum of 2 outlet ports for the connection of 2 independent lube circuits. A separate pump element is required for each outlet. Three pump elements with different delivery rates are available so that the volume of grease can be adjusted to the needs of the individual circuits.

This feature ensures that every lube point is supplied with an adequate amount of grease in each lubrication cycle. Control is provided by an integral IG502-I control and monitoring unit; it can be operated in a time- or load- (pulse) dependent mode, and with or without monitoring.

The control system provides the following advantages:

- Non-volatile memory with PIN-code protection
- Timer setting:
Working time 1 ... 99 min.
Pause time 1 ... 99 h.
- Storage of residual interval and lubricating cycle
- Storage of fault signals (diagnosis memory)
- Data save in event of a power failure
- Connection for external pushbutton
- Connection for inductive cycle switch
- Interval and contact times can be set independent of each other, even with monitored systems
- Electrical connections easy via 7-pole plug connector

Please order cable harness separately.
Contact SKF for ordering information.



Ordering details		
Piston pump Order no.	Reservoir capacity (liters)	Grease filling
KFA1	1	Via conical head nipple via topping-up pump
KFAS1 (incl. control system)	1	Via conical head nipple via topping-up pump

A "W" has to be appended to the order no. for pump units with filling level monitoring,
order example: KFAS1-W

The following has to be appended to the pump's order number:
for operating voltage, +912 (12 V DC), +924 (24 V DC)
Order example: KFA1 +912

1) The indicated rates refer to the delivery of NLGI grade 2 grease at an operating temperature of 20 °C and a back pressure of 50 bar. Temperatures and pressures that deviate from these figures lead to different delivery rates.
The indicated values must be taken as a basis in the design of a centralized lubrication system.

Ordering details	
Pump elements Order no.	Delivery rate ¹⁾ (cm ³ /min)
KFA1.U1	2,0
KFA1.U2	1,5
KFA1.U3	1,0

SKF MultiFlex

Pump units, series KFG and KFGS

Applications

General machinery, on- and off-road, cranes, wind turbines, mixers etc.

Features

- Durable construction
- Designed for grease NLGI grade 2 and system pressure up to 300 bar
- Easy installation, max. 3 pump outlets
- Highly effective lubrication monitoring with piston detector feedback from progressive feeders
- Fully-automated operation with use of electronic control system
Working time 1 ... 99 min.
Pause time 1 ... 99 h.
- Built-in reservoir agitation prevents grease separation and eliminates entrained air in the system
- AC version designed for 90-264 V AC, 50 to 60 Hz.



For additional information please refer to our brochure: Leaflet No. 1-3030-EN

Online available at www.skf.com/lubrication

KFG order code

Order No. for basic pump: _____

KFGS 1-5 X / A X X / 0005-230VAC

Control unit _____

= without integrated control unit

S = with control unit

Tank capacity: _____

1 = 2 kg

3 = 6 kg

5 = 10 kg

Pump housing version _____

5 = standard version

Level switch: _____

X = without level switch

W1 = level switch for grease NLGI ≥ 2

W2 = level switch for grease NLGI ≤ 1

Pump elements (max. 3) _____

X = without element

A = 2,5 cm³/min

B = 1,8 cm³/min

C = 1,3 cm³/min

D = 0,8 cm³/min

Tube connector _____

/ = without tube

A = for Ø 6 mm tube

B = for Ø 8 mm tube

C = for Ø 10 mm tube

Pump version _____

0005 = standard version

Operating power _____

12 V DC , 24 V DC or 230 V AC

1 2 3

pump element 1 to 3



KFG/KFGS pump units with 10, 6 and 2 kg reservoir



Special version with cabinet

SKF MultiFlex

Pump units, series FF and FB

Applications

General heavy duty applications, crushers, steel industry, mining

Features

- Sturdy design with built-in agitator for grease up to NLGI grade 3
- Adjustable pumping elements
- Steel tank size 4, 6, 10, 15 or 30 kg
- Available with different ratios and element sizes covering 0.04 to 7 cm³/min
- Robust 3 ph. e-motor for continuous and discontinuous operation

FB order code

Order No. example:

FB 15 E 2M04H 05 12 00 C D0001 AF07

Tank capacity

06 = 6 kg
15 = 15 kg
30 = 30 kg

Level switch

X = without level switch
E = low level

Type of drive

2M04H, 45:1

Pumping elements (max. 24)

Number of elements Ø 6 mm, Q = 0,8 - 2,4 cm³/min, 350 bar
 Ø 8 mm, Q = 1,4 - 4,4 cm³/min, 200 bar
 Ø 10 mm, Q = 2,2 - 6,8 cm³/min, 125 bar

Tube connector

A = tube Ø 6 mm
B = tube Ø 8 mm
C = tube Ø 10 mm
D = 1/4 " NPT

Pump version

D 0001 = standard version

Operating power

AF07 = 230/400 V AC, 50 Hz, IP 55F-0.25 kW

number of pump elements Ø 6 mm

number of pump elements Ø 8 mm

number of pump elements Ø 10 mm



For additional information please refer to our brochures:

FF pump, Leaflet No. 1-3025-EN
FB pump, Leaflet No. 1-3026-EN

Online available at
www.skf.com/lubrication



Pump unit FB, max. 24 pumping elements



Pump unit FF, max. 12 pumping elements

SKF DuoFlex

Dual-line lubrication systems designed for oil, semi-fluid grease and hard grease NLGI grades 000 to 3

SKF DuoFlex systems are designed for medium-sized or large machines with a large number of lubrication points, long lines and harsh operating conditions.

Applications include heavy industry, metal working plants, pulp and paper, mining, mineral processing and cement factories, deck cranes, power plants and more.

The system requires two main lines that are alternately supplied with lubricant. SKF DuoFlex systems are very reliable when using hard greases and when the distance to the pumping unit is long – up to 100 m or more.

They also offer great flexibility when it comes to adjusting the metered quantity to the requirements of the specific lubrication point. In addition, the parallel set-up of the dual line metering valves allows for a simple and easy system design.

SKF DuoFlex dual-line lubrication systems can supply more than 1 000 lubrication points from a single pump unit source, resulting in high lubricating reliability with pressures of up to 400 bar.

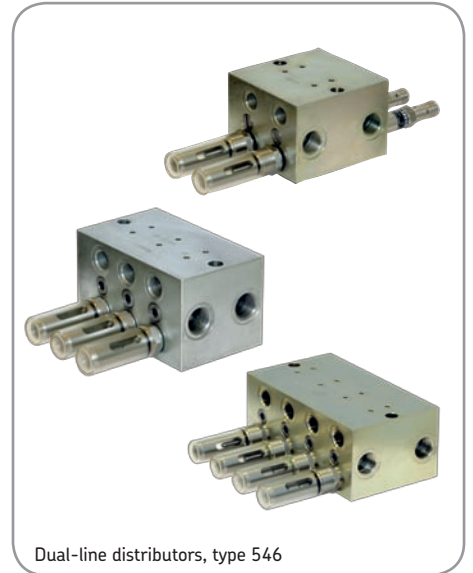

Dual-line distributors, type 546



Hydraulic and electrical control units for dual-line central lubrication systems with control cabinet

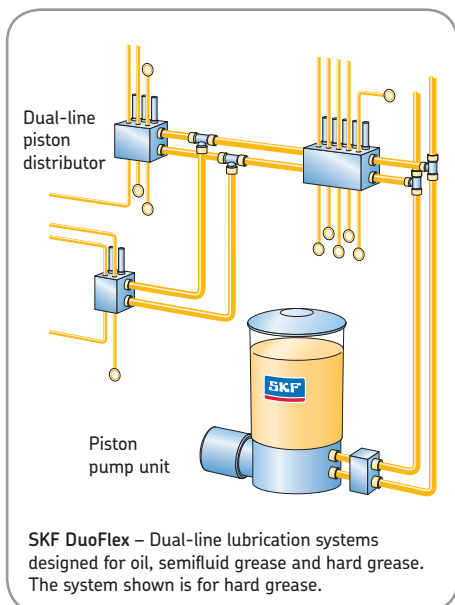

Automatic dual-line pump, type FK



Automatic dual-line pump, type FD3

SKF DuoFlex

Pump units, series SKF Multilube

The SKF Multilube pumping unit is a revolutionary and superior solution for lubricating individual machines and equipment. Easy to install, compact pumping unit structure and easiness in operation ensures functionality in machine and equipment specific applications, even when used outdoors.

Centralised lubrication improves runnability

The high-quality SKF Multilube pumping unit prevents bearing failures and improves the runnability of machines and equipment. Due to a centralised lubrication system the lubrication result is always optimal, consequently reducing energy and lubricant consumption.

Compact and flexible solution

All relevant components and functions (control unit, pump, reservoir, directional valve and pressure monitoring) are integrated into the modular pumping unit SKF Multilube. Built-in heating enables operation and use even under demanding and cold circumstances.

All SKF grease and oil dosers for single and dual line systems can be used with the SKF Multilube unit.

Auxiliary equipment such as spray and sliding surface nozzles and lubrication brushes can be used according to the lubrication needs.

Advantages and features

- Compact all-in-one structure
- Modular and durable design
- Easy to install and start-up
- Can be used in single line, dual line and progressive lubrication systems
- SKF Multilube pumping unit can be used in oil and grease lubrication systems
- Suits all pumpable oils and greases
- Two reservoir sizes
- Pumping element equipped with pressure relief valve
- Filling connection equipped with safety valve
- Visual and electric low level monitoring in reservoir
- Pumping centre is equipped with heating resistor
- Clear and versatile user interface
- Field data can be read externally
- Wide operation temperature range -30 to +70 °C (-22 to +158 °F)

Designation system for SKF Multilube Pumping Unit MLP

Example: MLP-10-2-230-IF103-PSE

MLP - 10 - 2 - 230 - IF103 - PSE

Identification of product design

MLP SKF Multilube Pump

Identification of reservoir size

4 4 litres
10 10 litres

Identification of number of lines

1 Single line system
2 Dual line system

Identification of power supply

24 24 V control voltage if external control is used
115 Power input 115 V
230 Power input 230 V

Identification of user interface

IF103 User interface
24 External control, control voltage 24 V DC
115 External control, control voltage 115 V AC

Identification of pressure control

PSE Built-in pressure sensor
C2 Singleline dual channel lubrication pump used with spring distributors
C2P Progressive dual channel lubrication pump used with progressive divider



For additional information please refer to our brochure:

Leaflet No.
SKF Multilube 6407/I-EN

Online available at
www.skf.com/lubrication

SKF DuoFlex

Pump units, series FK

The FK pump unit is a piston pump for small to medium sized dual-line lubrication systems. The all-in-one solution is available with all necessary valves and designed for harsh operating conditions with system pressures up to 400 bar.

Grease pump unit with gear reduction, agitator, steel reservoir with ultrasonic level switch, filler socket and screw cap, safety valve, e-motor 3ph 230 /400 VAC, 50 Hz, 0,37 kW -lp55F, p max 400 bar. Hydraulic connections 1/2" for oils from 50 mm²/s up to greases NLGI grade 3. Built-in screw-conveyor allows the use of hard greases, NLGI grade 3

- Available with 1 to 6 internal pumping elements covering 0,67 to 4 kg/h
- Available with different valve arrangements for:
 - Progressive lubrication systems
 - Single-line lubrication systems



For additional information please refer to our brochure:

Leaflet No.
FK pumps 1-3033-EN

Online available at
www.skf.com/lubrication



Order code	El.change-over valve with pressure gauges	Reservoir size			Output	
		15 kg	30 kg	60 kg	2 kg/h	4 kg/h
FK 2/15 U21M04/ 3 /400 M23 /001AF07	x	x			x	
FK 2/30 U21M04/ 3 /400 M23 /001AF07	x		x		x	
FK 2/60 U21M04/ 3 /400 M23 /001AF07	x			x	x	
FK 2/15 U21M04/ 6 /400 M23 /001AF07	x	x				x
FK 2/30 U21M04/ 6 /400 M23 /001AF07	x		x			x
FK 2/60 U21M04/ 6 /400 M23 /001AF07	x			x		x
FK 3/15 U21M04/ 6 /400 /3 /001AF07		x			x	
FK 3/30 U21M04/ 3 /400 /3 /001AF07			x		x	
FK 3/60 U21M04/ 3 /400 /3 /001AF07				x	x	
FK 3/15 U21M04/ 6 /400 /3 /001AF07		x				x
FK 3/30 U21M04/ 6 /400 /3 /001AF07			x			x
FK 3/60 U21M04/ 6 /400 /3 /001AF07				x		x

SKF DuoFlex

Pump units, series FD3

The FD3 pump unit is a powerful axial piston pump for medium to large sized dual-line lubrication systems with up to 1 000 lubrications points.

The basic design with safety valve, grease filter and pressure gauge is available in three tank sizes and three output versions.

- Outstanding quality suitable for rough operating conditions
- Built-in agitator, eliminates entrained air prevents grease separation and allows grease NLGI grade 3
- Continuous flow rate create lowest system pressure losses and highest economical efficiency
- Grease pump unit with agitator, steel tank with ultrasonic level switch, safety valve, grease filter, pressure gauge range 0 to 600 bar, e-motor 3 ph 230/400 V AC, 50 Hz, 0,55 kW- IP55F, with p max. 400 bar and hydraulic connections 3/4"



For additional information please refer to our brochure:

Leaflet No.
DuoFlex pumps 1-0012-1-EN

Online available at
www.skf.com/lubrication



Order code	Output			Reservoir size		
	07 kg/h	14 kg/h	21 kg/h	45 kg	65 kg	100 kg
FD 3/07/45 U2/1M 0001 AG07	x			x		
FD 3/07/65 U2/1M 0001 AG07	x				x	
FD 3/07/100 U2/1M 0001 AG07	x					x
FD 3/14/45 U2/1M 0001 AG07		x		x		
FD 3/14/65 U2/1M 0001 AG07		x			x	
FD 3/14/100 U2/1M 0001 AG07		x				x
FD 3/21/45 U2/1M 0001 AG07			x	x		
FD 3/21/65 U2/1M 0001 AG07			x		x	
FD 3/21/100 U2/1M 0001 AG07			x			x

SKF DuoFlex

Dual-line distributors

Features

Dual-line distributors are used in dual-line centralized lubrication systems for greases up to NLGI grade 3 as well as for oil conforming to ISO VG with an operating viscosity greater than 50 mm²/s.

- Low pressure losses due to large distributor bores make it possible to combine a number of distributors in a row
- Infinitely adjustable
- Compact design
- Easy to combine ports (doubling dosing volume)
- Dual-line distributors can be equipped with piston detectors for electrical monitoring.
- Outlets quantity 1 to 8
- High lubricating reliability of distributors due to a maximum operating pressure of 400 bar
- Available in stainless steel version, adjustable or fix settled metering screw, and with protecting caps in aluminum or stainless steel instead of plastic
- Replaces other manufacturer's dual-line valves



For additional information please refer to our brochure:

Leaflet No.
DuoFlex distributors 1-0012-3-EN

Online available at
www.skf.com/lubrication



Part no.	Max outlets	Output range per stroke	Supply connections	Discharge connections
546-101-015	2	0-5 cc	G 3/8"	G 1/4"
546-201-015	4	0-5 cc	G 3/8"	G 1/4"
546-301-015	6	0-5 cc	G 3/8"	G 1/4"
546-401-015	8	0-5 cc	G 3/8"	G 1/4"
546-101-011	2	0-1.5 cc	G 3/8"	G 1/4"
546-201-011	4	0-1.5 cc	G 3/8"	G 1/4"
546-301-011	6	0-1.5 cc	G 3/8"	G 1/4"
546-401-011	8	0-1.5 cc	G 3/8"	G 1/4"
546-101-004	2	0-0.5 cc	G 3/8"	G 1/4"
546-201-004	4	0-0.5 cc	G 3/8"	G 1/4"
546-301-004	6	0-0.5 cc	G 3/8"	G 1/4"
546-401-004	8	0-0.5 cc	G 3/8"	G 1/4"

SKF DuoFlex

Dual-line accessories

Change-over valve

Hydraulic or electrical change-over valves are used in dual-line centralized lubrication systems to control main feed lines 1 and 2. Starting from the lube pump, the main feed lines are alternately used as pressure (P) and return (R) lines.

Differential pressure switch

The differential pressure switch is used to control the system function. It is installed upstream of the dual-line distributor farthest from the pump to ensure sufficient pressure to all dual-line distributors even under low temperature conditions and with long feed lines.

Electrical control units

The process routine of dual-line centralized lubrication systems is controlled and monitored with electrical control units. It is possible to choose between continuous and automatic operation on a full-cycle or half-cycle basis. The interval time in the automatic mode is adjustable. The monitoring covers the lube pump with reservoir filling level, the pressure build up and delivery rate as well as the change-over routine.

It also checks for leakage in the main feed lines and branch lines all the way to the dual-line distributors. Any fault signals are displayed by control lights mounted on the front of the control cabinet or by moving text on an optional panel on the front. At the same time, fault signals can be received from potential-free contacts. A link up with existing Profibus systems for display and evaluation in the PCS (process control system) is possible.



For additional information please refer to our brochure:

Leaflet No.
DuoFlex control units 1-0012-2-EN

Online available at
www.skf.com/lubrication



Order No.		Order No.	
24-1883-2538 24-1883-2534	SSY50 hydraulic change-over valve SSY50/1 without piston detector SSY50K1 with ec. piston detector	24-2583-2498	Differential pressure switch DDS50/1 DDS50/1 with 50 bar differential pressure
24-1883-2343 24-1883-2344 24-1207-2226	SSY203 electromagnetic change-over valve SSY 203/24DC with socket straight, without pressure gauge SSY 203/230AC with socket straight, without pressure gauge Pressure gauge (1x with hardware) 0 to 600 bar	24-1074-2062 24-1074-2063	Electrical control cabinet Complete control cabinet for a 1-string dual-line system with an axial piston pump, Type FD3 U = 230/400 V AC Complete control cabinet for a 2-string dual-line system with an axial piston pump, Type FD3 U = 230/400 V AC

SKF CircOil

Circulating oil lubrication systems

SKF CircOil systems are designed primarily for circulating oil lubrication to not only lubricate but also to cool highly stressed bearings in nearly every size of machine used in the pulp & paper sector and heavy industry.

They also efficiently remove dirt, water and air particles. An oil supply system delivers the lubricant to the adjustment valves with individual settings. The actual feed rates can be controlled visually or electronically. Monitoring systems with a flow rate read-out function and individual warning levels are available for a more predictive maintenance approach. SKF CircOil systems include a wide range of tailor-made and turnkey solutions for flow rates from 0,1 to 3 000 l/min.

This solution includes the SKF Streamline Pumping Unit, with a tank capacity as high as 40 000 liters, and innovative oil reservoirs such as the SKF Flowline Pumping Unit that helps reduce oil consumption dramatically. SKF CircOil systems are easy to service. In addition, they feature a modular design and can be easily combined.



SKF Flowline Monitor and SKF Safeflow flowmeter



Flow limiters

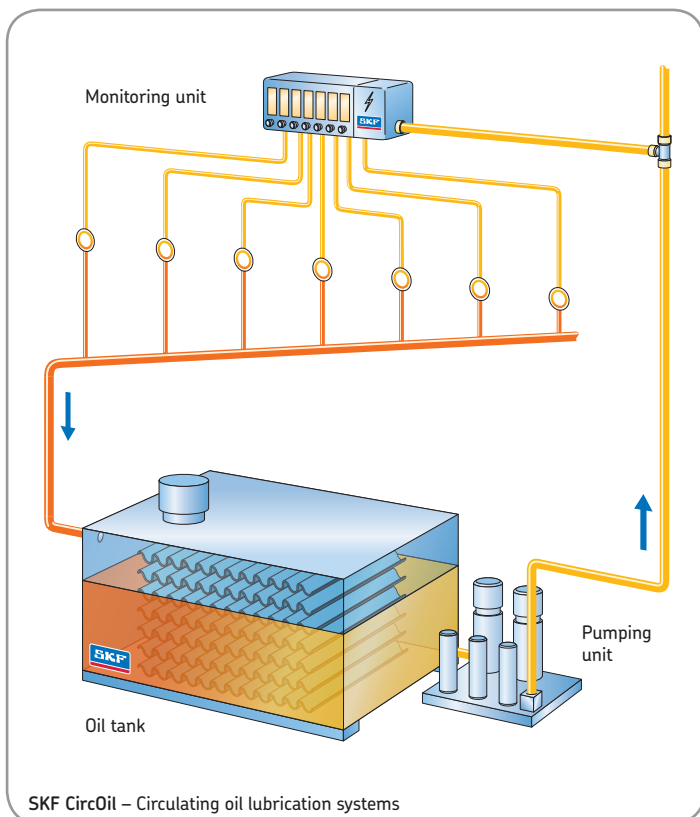

SKF CircOil – Circulating oil lubrication systems



SKF Streamline Pumping Unit

SKF CircOil

Oil supply units

SKF Oil supply units are not just tailor made, they also comply with the local safety regulations and environmental constraints.

The overall supply system concept is especially designed for the use with lubricating oil which is more viscous than hydraulic oil.

Consequently we offer following fine tuned solutions:

Oil tanks: Available in steel or stainless steel with special baffle plate arrangements. From a tank size of 1 000 l we suggest the SKF plate separator technology. This unique design feature allows for a highly efficient use of oil in the tank and eliminates foam resp. air bubbles (degassing) and settles free water and heavy particles. As a result, oil tanks become a lot smaller. On request incl. oil sensors for water content, oil aging etc.

Oil pumps: Gear type or screw type pumps. Dependent on the application also in a redundant or in explosion proof design (ATEX).

Oil filters: Single or double filters in all purity classes with visual or electrical clogging detection.

Oil heaters: Usually based on electric solutions with low surface load, for larger systems also with steam heaters and/or heat carrier oil solutions.

Oil coolers: Air or water coolers, tube or plate type design, with all necessary valves and regulating equipment.

Total system design: Electrically pre-wired on terminal boxes or PCS based as a stand-alone system. Turn-key solutions, installed on the spot, including flow meters or flow limiter systems.

Capacity:

Tank sizes up to 40 000 l.

Flow rates up to 3 000 l/min.

Please contact your local SKF application engineer for assistance.



SKF CircOil

SKF SM-100 Oil Pumping Unit

Fan units

This circulation oil lubrication unit is ideal for rolling bearings on industrial fans where high speeds and/or high temperatures can preclude the use of grease. These units deliver a continuous flow of cooled and filtered oil directly to the bearing. The metered pump flow is matched to the bearing and housing size, preventing oil leaks and excessive heat associated with oversized pumping systems.

The SKF SM-100 Oil Pumping Unit is available in three tank sizes; 30 liter, 50 liter and 100 liter.

Bearings with shaft sizes from $1\frac{1}{8}$ in. to $5\frac{1}{2}$ in. can be adequately lubricated with this circulating oil lubrication unit.

Features

- Large reservoirs cool oil quickly
- Large reservoirs de-aerate the oil properly
- Control options provide flexible installation and operation
- High pressure filtration up to 1 000 psi
- Easy to read level gauge
- Increased safety with back-up pump option for critical applications
- Non-tapered, threaded connections on the pressure side of the system help avoid leaks

Please contact your local SKF application engineer for assistance.



30 liter tank - basic unit, no controls



100 liter tank-unit with controls

SKF CircOil

Single-circuit pump units

The pump units specified in this section are lubricant delivery pumps without pressure relief fixtures and are designed for continuous operation in circulating and hydrostatic lubrication systems. These pump units may also be used for hydraulic tasks to the extent permitted by the pressure and viscosity ranges stated in the tables. The drive is provided by a three-phase motor designed for a rated voltage of 230/400 V to DIN IEC 38. The permissible pressure and delivery rates vary with the viscosity. When using oils with viscosities outside the indicated ranges (spindle oils and highly viscous oils), please consult SKF for further information. Please note that even standard oils may become thin-bodied or highly viscous due to changes in temperature.

Ambient temperature maximum
+40 (104 °F)

Lubricant temperature
0 to +80 °C (32 to 176 °F)

Explanation of the hydraulic function

Referring to the diagrams below, oil is sucked in at S and flows through the pressure duct in direction P. The oil pressure closes valve V and opens valve E3 against spring tension. If air is entrained (due to low oil level in the reservoir), valve V remains open and bleeds the air or the air-intermixed oil into the return duct (see arrows marking the flow in directions R1 and R2 respectively). Valve C1 allows the excess-pressure oil to flow into the return duct.

Explanation of the structural differences

With type MF, the short screw plug D2 leaves flanged port R2 open – contrary to D1 with type M – and a plug seals external port R1. Flanged port R2 of the return duct discharges directly into the reservoir without any threaded connections (see Fig. 2 and 3).



Gear pump unit MF



Gear pump unit UD

Type MF units for flange-mounting on oil reservoir

Use a special sealed pump for horizontal flange-mounting of the unit **beneath oil level**

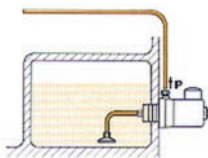

Figure 1

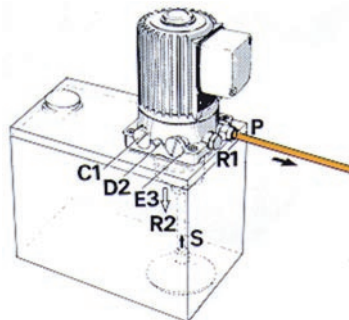

Figure 2

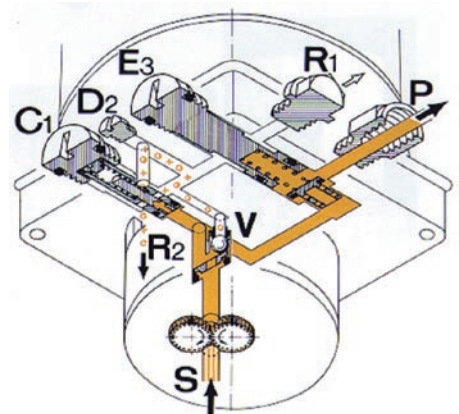

Figure 3

Ordering details - single circuit gear pump units

For flange-mounting on oil reservoir	Output ¹⁾	Maximum back pressure	Permissible operating viscosity range	Suction head (with open pressure line)	Three-phase motor Rated output	Rated speed	Rated current at 50Hz, 230/400 V	Suction port S
Order no.	l/min	bar	mm ² /s	mm	kW	rpm	A	thread d1
MF2	0,2	27 (60)	20 - 2000	500	0,075	2700	0,05/0,29	M14 × 1,5
MF5	0,6	27	20 - 1000	500	0,075	2700	0,05/0,29	M14 × 1,5
MF10	1	17,5	20 - 1000	500	0,075	2700	0,05/0,29	M16 × 1,5
MF210	2	15	20 - 1000	500	0,075	2700	0,05/0,29	M16 × 1,5

1) Output based on an operating viscosity of 140 mm²/s at a back pressure of p = 5 bar

2) Also see leaflet 1-1202-EN page 6: Multirange voltage motors.

Single-circuit units complete with reservoir see page 53.

Standard dimensions of reservoirs starting at 30 liters (dimensions in mm)

Reservoir capacity	Height			Width		Depth		Center distance	Center distance	Hole
	liters	h	h2	h3	b1	d1	b2			
30	375	245	237	510	320	430	240	14		
50	480	310	300	570	350	490	270	14		
100	510	340	326	710	500	630	420	14		

30 and 50 liter reservoirs available, also without legs, for wall-mounting.

- 1 = Oil filler cap
- 2 = Oil strainer
- 3 = Float switch
- 4 = Gear gerotor pump unit
- 6 = Oil level indicator
- 7 = Oil drain plug

Reservoir and cover: hammered enamel finish. The complete reservoir units are also available in conformity with the regulations of the automobile industry. DIN and special reservoirs on request.

Example: 50 liter reservoir

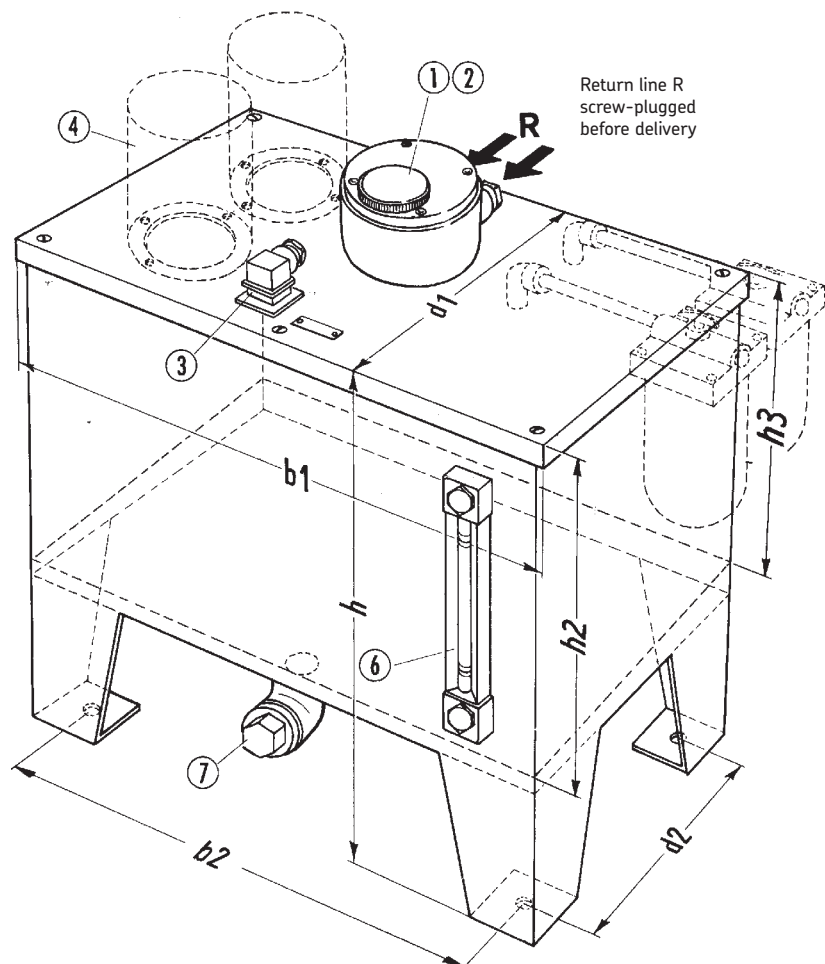

For additional information please refer to our brochure:

	Leaflet No.
Gear pumps unit for single line	1-1202-EN
Single and multicircuit pumps	1-1204-EN
UD/UC Pump units	1-3019-EN

Online available at www.skf.com/lubrication

SKF CircOil

SKF Safeflow oil flowmeters

SKF Safeflow oil flowmeters are used for controlling and measuring the flow rate of lubricants in oil lubrication systems.

The base is made of durable aluminum. The flow tube is made of glass, so high temperatures and the use of synthetic oils should present no problems.

The SKF Safeflow flowmeter has a straight glass flow tube with an internal calibrated cone extending along its vertical axis. The float is cylindrical, its O.D. being the same dimensions as the I.D. of the flow tube, with an annular opening through its center along its vertical axis. In operation, the calibrated cone extends through the annular opening in the float, creating the variable orifice needed for measurement as the float moves with flow changes.

Because the oil flows through the float, rather than around it as in ordinary flowmeters, the float is always clearly visible. A white Teflon ring on the float marks the reading point and wipes the inside wall of the glass tube. The flowmeter can be field calibrated so that when the desired oil flow is properly adjusted, the white ring will line up with a predetermined mark. This makes it easy to monitor banks of flowmeters with different required flows because all floats

will be at the same level and it will not be necessary to remember the correct flow value for each bearing.

Flow change alarm system

The oil flow through each SKF Safeflow flowmeter can be remotely and continuously monitored. The alarm system consists of one alarm sensor for each flow tube and one monitoring unit for up to ten alarm sensors. The alarm sensor is an inductive proximity switch, which identifies the location of a metal float in the tube. The monitoring unit contains the terminals and the power supply for ten sensors. The system transmits either a single alarm from each bank of meters or a separate signal from each flow tube. The alarm delay can also be selected to avoid false alarms.

! For additional information please refer to our brochure:
 SKF Safeflow Leaflet No. 6409-EN
 Online available at www.skf.com/lubrication



Technical data SKF Safeflow

Flow rate at:	SF05A	SF10A	SF15A	SF20A	SF30A
100 cSt	0,1 - 0,7 l/min	0,1 - 3,0 l/min	0,3 - 7,2 l/min	1,3 - 17,0 l/min	5 - 56,0 l/min
220 cSt	0,04 - 0,35 l/min	0,1 - 1,7 l/min	0,2 - 4,4 l/min	0,6 - 10,6 l/min	2,5 - 44,0 l/min
Outlet qty	1,2,4,6,8,10	1,2,4,6,8,10	1,2,4,6,8,10	1,2,4,6	1
Inlet/outlet	G1/2" / G1/2"	G1" / G1/2"	G1" / G1/2"	G1" / G3/4"	G1/4" / G1/4"

SKF CircOil

SKF Flowline Monitor – oil flow rate monitoring system

SKF Flowline Monitor flow rate monitoring system introduces a new digital dimension for measuring and controlling oil circulation lubrication system flow rates. Flowline flowmeters operate individually and they can be programmed as well as adjusted separately. They can also be connected to a centralised control system. In the Flowline's graphical design, user friendliness is a major focus. With one glance, operators can see the flow rate status of each individual lubrication point from the Flowline Monitor.

Advantages of the Flowline Monitor

- Extensively adjustable, even for small amounts of flow
- Wide adjustment range; parameters set at flow tubes are easily visible
- Practical and visual LED-indicator system
- Clear digital display
- Alarm trends follow-up
- Electronic temperature measurement
- Temperature compensated flow rate measurements
- Modern design



For additional information please refer to our brochure:

SKF Flowline Monitor Leaflet No. 6410-EN

Online available at www.skf.com/lubrication



SKF Flowline Monitor

SKF Flowline monitor

Flow rate at:	FL15	FL50
220 cSt	0,05 - 15,0 l/min	5,0 - 50 l/min
Outlet qty	1,2,4,6,8,10	1
Inlet/Outlet	G1" / G1/2"	G1" / G1"

SKF CircOil

Flow limiters for oil

Flow limiters are used in large oil circulating lubrication systems. The task of a flow limiter is to divide up the volumetric flow of the main line into parallel individual volumetric flow quantities and to "limit" these according to requirements, or to keep them constant. The volumetric flow generated is independent of the system pressure and virtually independent of viscosity. The signal transmitter version creates a fault signal as soon the flow rate drops < 80%. Rotary gear versions create one pulse per revolution and allow a continuous flow rate measurements.

Advantages

- Reliable
- Self-adjusting metering, thus identic volume flows stable system constitution
- Easy system design The required volume flow and nozzle size are determined during the engineering phase
- Space-saving installation thanks to a common base plate with only one inlet for up to 6 flow limiters
- Easy start up, pre-adjusted volume flows enable short start up periods
- Effective monitoring of volume flow with gear wheel-type flow indicator, with Hall sensor signal transmitter
- Optional ATEX-versions
- Preferred technique to feed:
 - Plain and roller bearings
 - Gear nips and spray nozzles
 - Progressive systems
 - Gear boxes
 - High stressed machines with oil circulation requirements



For additional information please refer to our brochures:

	Leaflet No.
Flow limiter SP/SMB3 and SP/SMB6	1-3001-EN
Flow limiter SP/SMB8	1-3028-EN
Flow limiter SP/SMB9	1-3002-EN
Flow limiter SP/SMB13	1-3003-EN
Flow limiter SP/SMB14	1-3004-EN

Online available at www.skf.com/lubrication

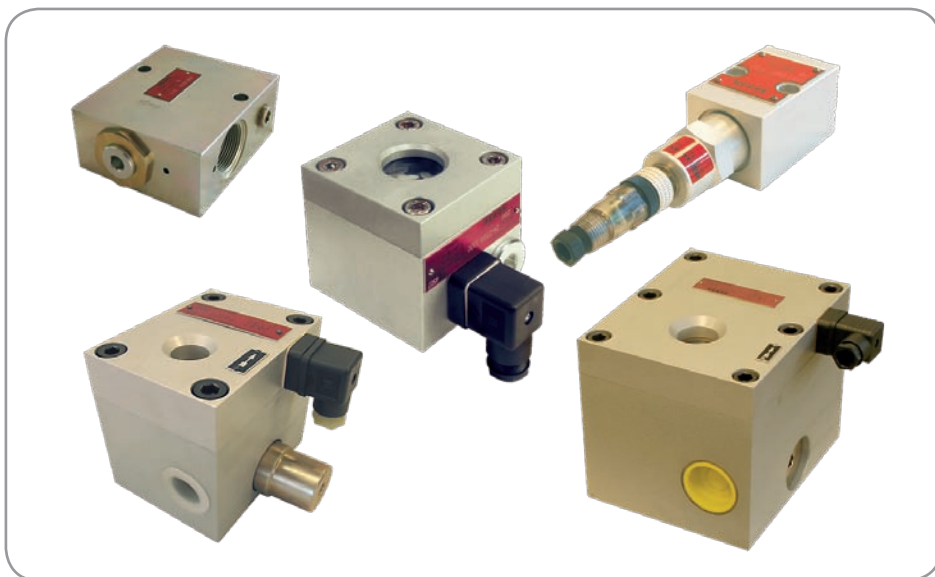

Flow limiters

SP/SMB	3	6	8	9	13	14
Flow rate l/min	6 - 38	25 - 132	0,1 - 8,1	0,1 - 8,1	6 - 38	25 - 132
with static signal transmitter	•	•	•	•	•	•
with rotary gear indicator			•	•		
with base plates 1.. 6 outlets						
Volume/Revolution/Impulse cm ³				12,0	39,0	106
Pressure	5 - 200 bar	5 - 200 bar	5 - 200 bar	6 - 50 bar	6 - 50 bar	6 - 50 bar
Connection inlet	G 3/4"	G 1 1/4"	G 1 1/2"	G 1 1/2"	G 3/4"	G 1 1/4"
Connection outlet	G 3/4"	G 1 1/4"	G 3/8"	G 3/8"	G 3/4"	G 1 1/4"

SKF CircOil

Flow monitors and sensors for oil

Flow monitors and sensors have the task of monitoring the flow of oil from the pump or a piston distributor element to the lube point. Flow monitors with various designs are used for this job. Flow monitors / sensors monitor the flow of oil from a piston distributor to the lube point, the piston distributor metering out a small amount of oil for only a short period of time. Depending on the type, flow monitors / sensors can monitor oil quantities ranging from 10 mm³ all the way to 1 500 mm³ per lubricant pulse.

A further task involves monitoring a continuous flow of oil from a pump through a lubrication system. These flow monitors are designed for a throughput ranging from 50 cm³ to 14 000 cm³. The following issues should be considered when selecting an appropriate flow monitor:

- Intermittent or continuous operation
- Oil quantity to be monitored
- Effective viscosity of the lubricant
- System pressure



Ordering details					
Order no.	Designation	Metered quantity, flow rate	Application	Port A	Port B ¹⁾
171-210-051	Flow monitor	50 - 100 cm ³ / min	Circulating central lubrication systems	M10 x 1	M18 x 1,5
171-210-052		100 - 200 cm ³ / min		M10 x 1	M18 x 1,5
171-210-053		200 - 500 cm ³ / min		M10 x 1	M18 x 1,5
171-210-054		500 - 800 cm ³ / min		M10 x 1	M18 x 1,5
171-210-055		800 - 1800 cm ³ / min		M10 x 1	M18 x 1,5
171-210-061	Flow monitor	1,6 - 2,5 liters / min	Circulating central lubrication systems	M18 x 1,5	M18 x 1,5
171-210-062		2,3 - 4,0 liters / min		M18 x 1,5	M18 x 1,5
171-210-063		3,6 - 6,0 liters / min		M18 x 1,5	M18 x 1,5
171-210-064		5,5 - 10,0 liters / min		M18 x 1,5	M18 x 1,5
171-210-065		8,0 - 14,0 liters / min		M18 x 1,5	M18 x 1,5
GS300 GS304N GS304P	Flow sensor	10 - 600 mm ³ / pulse	Intermittent central lubrication systems ²⁾		
		10 - 600 mm ³ / pulse	Intermittent central lubrication systems ²⁾		
		10 - 600 mm ³ / pulse	Oil + air central lubrication systems		
GS4011-S20 GS6011-S20 GS4011-S50 GS6011-S50	Oil-streak sensor	120 - 600 mm ³ / h	Oil + air central lubrication systems		
		120 - 600 mm ³ / h	Oil + air central lubrication systems		
		60 - 120 mm ³ / h	Oil + air central lubrication systems		
		60 - 120 mm ³ / h	Oil + air central lubrication systems		



1) DIN 2353 / ISO 8434-1. Only permissible for the use of preassembled fittings. We recommend use of a preassembled EO-2 screw union. (Example: GA21 ...23/GA30).

2) e.g. with piston distributors, metering elements, injection oilers

Flow monitors for the monitoring of a continuous flow of oil

GS300, GS304N, GS304P

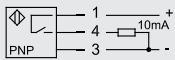
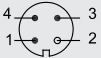
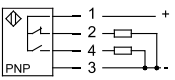
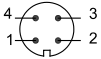
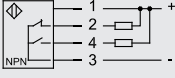
Flow sensors for monitoring of lubricant feed right at the lube point

Ordering details			
Order no.		Switching function	Electrical connection
GS300		Pin 1 (BN - brown): +24 V Pin 3 (BU - blue): 0 V Pin 4 (BK - black): PNP / NO - closes in event of flow	
GS304P		Pin 1 (BN - brown): +24 V Pin 2 (WH - white): PNP / NC - opens in event of flow Pin 3 (BU - blue): 0 V Pin 4 (BK - black): PNP / NO - closes in event of flow	
GS304N		Pin 1 (BN - brown): +24 V Pin 2 (WH - white): NPN / NC - opens in event of flow Pin 3 (BU - blue): 0 V Pin 4 (BK - black): NPN / NO - closes in event of flow	

GS4011-S..., GS6011-S...

The oil-streak sensors monitor the continuity of the oil flow in oil + air lubrication

Oil + air centralized lubrication systems are used to supply high-speed rolling bearings in tool spindles with extremely small quantities of lubricant for such applications. To achieve such small quantities of oil per unit of time, what was originally a relatively large drop of oil is broken down by a current of air on its way from the metering point to the bearing. The oil to be delivered is fed in the line to the bearing as a thin flow of lubricant along the wall.

Monitoring

So far, only the metered quantity of oil from the metering element has been checked upstream of the oil and air mixing point. The oil-streak sensor makes it possible to monitor the transport of a fine current of oil along the secondary line's wall downstream of the oil and air mixing point.

The closer the sensor is located to the lube point, the more reliable the system monitoring.



For additional information please refer to our brochure:

Leaflet No.

Flow Monitors and Sensors

1-1704-EN

Online available at www.skf.com/lubrication

Ordering details

Order no.	Plastic tubing Ø D	Flow rate mm ³ /h
GS4011-S20	4	120 - 600
GS4011-S50	4	60 - 120
GS6011-S20	6	120 - 600
GS6011-S50	6	60 - 120

SKF CircOil

Level switches

For oil, hydraulic and fluid reservoirs

Level switches are used to monitor the level of fluids in unpressurized reservoirs. Various versions are available to meet the different requirements necessary for the monitoring of fluid levels.

- Switches with one switching point (WS32-...), e.g. ones used to monitor the minimum level of fluid in a reservoir
- Switches with two switching points (WS35-...), likewise used to monitor the minimum level of fluid, emit an advance warning before a critical level is reached and without having to shut down the machine. Before the second switching point is reached, there is still enough oil in the reservoir for a shift to be completed without having to stop the machine or interrupt work
- Switches with two switching points (WS33-...), e.g. for a minimum and maximum level of fluid in the reservoir, automatic topping up of the reservoir being terminated, for example, before the maximum level is reached
- Further level switches, e.g. for other fluids like NLGI grades 000 and 00 grease, are available on request (capacitive proximity switches)

Tips for the use of level switches

Pay attention to the viscosity of oil!

Only use oils and other fluids with a maximum effective viscosity of 1 500 mm²/s.

Fluids with an effective viscosity greater than 1 500 mm²/s can lead to indication failures due to the increase in shear forces between the float and contact tube.

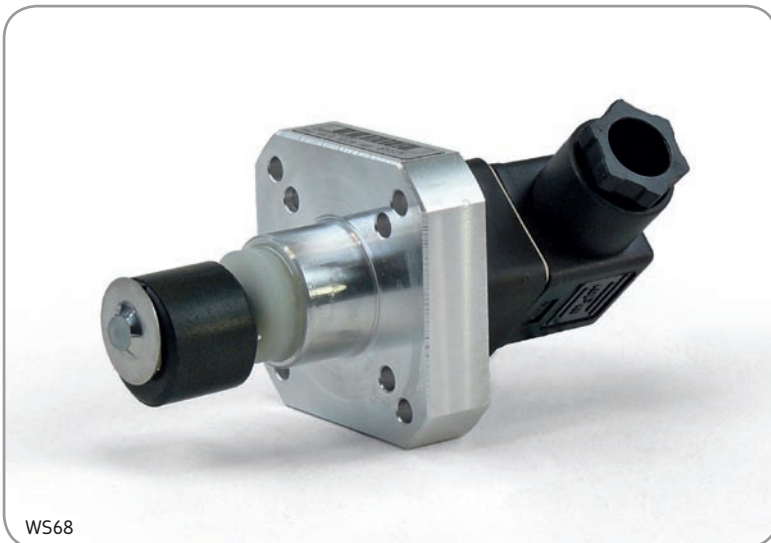

WS68



WS32-2



WS35-S30

WS32-2 / WS33-2 / WS35-2

When the level of fluid drops, a toric magnet built into the float actuates the reed contact cast into the contact tube. If necessary, the contact tube can be used to trigger a signal that calls for the reservoir to be topped off. The switching point for the minimum lubricant level is always 35 mm above the end of the contact tube.

The level switch WS33-... has an upper switching point for the maximum level in addition to the lower one. Control of automatic filling and emptying is possible with this model.

The level switch WS35-... has two contacts in the lower area that respond one after the other. The first switching point issues the advance warning. The second switching point can, after the float travels roughly 25 mm, break a connected command link and thus shut down a machine. The advance warning remains in effect.

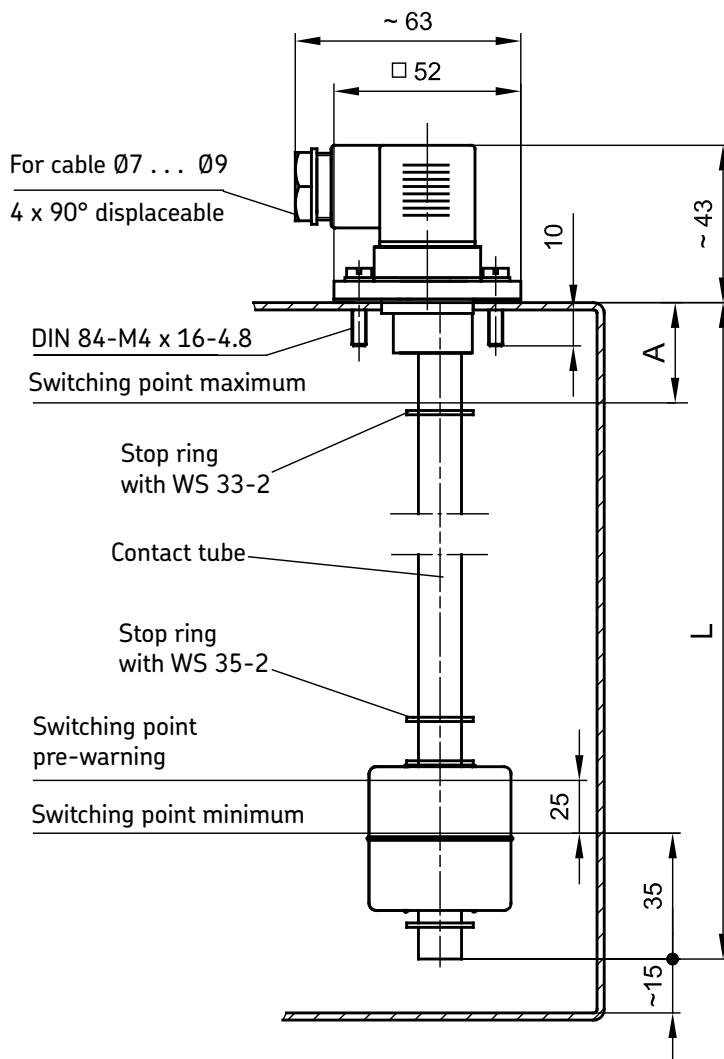
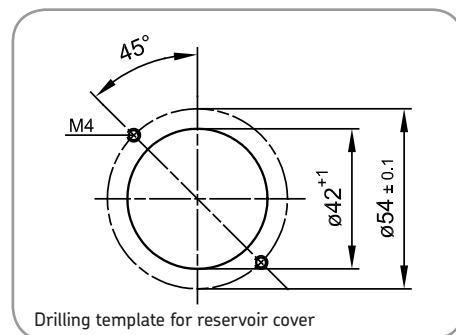

For additional information please refer to our brochure:
Leaflet No. 1-1702-EN

Ordering details

Group	Contact function / type of contact	Plug	Number of switching points
WS32-2	Minimum level / 1 changeover contact	Connector plug DIN EN 175301-803-A	1 switching point
WS33-2	Maximum level / 1 NO type Minimum level / 1 NC type	Connector plug DIN EN 175301-803-A	2 switching points
WS35-2	Advance warning / 1 NO type Minimum level / 1 NC type	Connector plug DIN EN 175301-803-A	2 switching points with fixed spacing approximately 25 mm



Accessories

Grease filler pumps.....	92
Grease pumps	92
Disposable gloves.....	93
Lubrication accessory sets.....	93
Connection systems.....	94
Fittings and accessories	96
Electric plug-and-socket connectors.....	99
Oil Check monitor.....	101
Handheld viscometer.....	101
Oil Safe	102
Technical data.....	103



Grease Filler Pumps LAGF series

High quantity grease packer

SKF filler pumps are suitable for filling grease guns. Especially designed for use on grease gun 1077600 and LAGH 400. Tested and approved for SKF greases. Easy to install and ready for use. Available for standard SKF 18 and 50 kg (39 and 110 lb) drums.

- Quick filling: low pressure allows higher stroke volume
- Easy to install: all necessary items are included
- Reliable: tested and approved for all SKF greases
- Can be used in combination with SKF bearing packer VKN 550



Ordering details

Designation	Description
LAGF 18	Grease filler pump for 18 kg drums
LAGF 50	Grease filler pump for 50 kg drums

Grease Pumps LAGG series

Meeting all your grease lubricator needs

Full range of manual and air-operated grease pumps are designed to empty standard 18, 50 or 180 kg (39, 110 or 400 lb) grease drums. Can be connected directly on the greasing points, also suitable for centralized lubricating grease systems.

SKF grease pumps have a maximum pressure of 400 and 420 bar (5 800 and 6 090 psi) respectively. Pumps are tested and approved for SKF greases. Easy to install and ready for use since pumps are supplied with all necessary items including 3 500 mm (137.8 in) of tubing.

- Full range; pumps available for 18, 50 or 180 kg (39 110 or 400 lb) drums
- High pressure; maximum of 420 bar (6 090 psi)
- Easy to install; all necessary items as well as 3 500 mm (137.8 in) of tubing are included
- Reliable; tested and approved for SKF greases
- Can be used in combination with SKF Bearing Packer VKN 550

Ordering details

Designation	Description
LAGG 18M	Grease pump for 18 kg drums
LAGG 18AE	Mobile grease pump for 18 kg drums
LAGG 50AE	Grease pump for 50 kg drums
LAGG 180AE	Grease pump for 180 kg drums
LAGT 180	Trolley for drums up to 200 kg



Disposable Grease-resistant Gloves TMBA G11D

Skin protection when handling grease

Specially designed to protect the skin when working with SKF bearing grease. The gloves are packed in a handy box containing 50 pairs.

- Non-powdered nitrile rubber gloves
- Close fitting for precision wear
- Excellent resistance against bearing greases
- Non-allergic



Lubrication accessory sets

Grease nozzles LAGS 8 / Grease nipples LAGN 120

The SKF LAGS 8 Grease nozzle kit provides the user with practical accessories for daily lubrication such as connectors, couplings and nozzles most widely used in the industry. To meet all of your needs for grease lubrication points, SKF has developed a grease fitting kit, LAGN 120, which contains a full range of 120 standardized conical grease fittings made of precision steel, zinc plated, hardened and blue chromated.

- Includes the most widely used accessories in the industry
- Upgrade the 1077600 grease gun with the LAGS 8 Grease nozzle kit
- Replace damaged grease fittings



Contents

Designation: LAGS 8

Straight pipe 180 mm and nozzle (DIN 71412)
 Hose with nozzle (DIN 71412)
 Tube with nozzle for button head nipples (DIN 3404)
 Tube with nozzle for Flush type nipples and plastic transport cover (DIN 3405)
 Nipple M10x1-G1/8
 Nipple M10x1-1/8-27NPS
 Nozzle (2*) (DIN 71412)

Contents

Designation: LAGN 120

Grease nipple

		Quantity
M6 x 1	straight	30x
M8 x 1	straight	20x
M10 x 1	straight	10x
G 1/8	straight	10x
M6 x 1	45°	5x
M8 x 1	45°	10x

Designation: LAGN 120

Grease nipple

		Quantity
M10 x 1	45°	5x
G 1/8	45°	5x
M6 x 1	90°	5x
M8 x 1	90°	10x
M10 x 1	90°	5x
G 1/8	90°	5x

Connection Systems

SKF quick connectors

The advantages of quick connections are obvious

- Greatly simplified installation – high cost-cutting potential
- Just one connection system for steel and plastic tubing – lower warehousing costs, simplified logistics, little danger of mixups during installation
- Triple seal – no leakage or ingress of dirt
- Easy to disconnect – saves time with modifications and repairs

The universal quick connector system for plastic and steel tubing

- Novel seal and locking concept meets the “zero leakage” requirements of industrial users
- Insensitive to dirt
- Easy to install
- Can be disconnected at the touch of a finger



Tools for the preparation of claw grooves on the ends of steel tubes

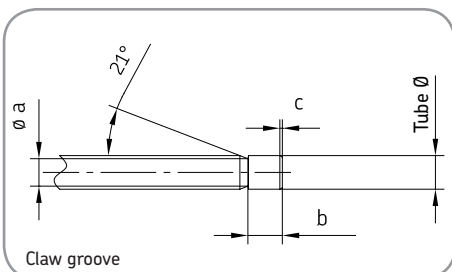
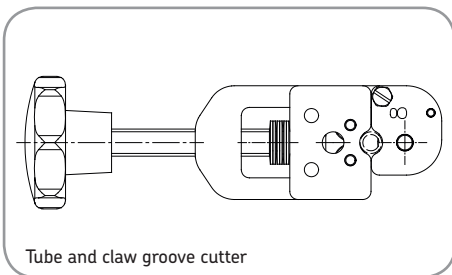

Ordering details

For tubings

Tube cutter
Order no.

Claw groove dimensions

4
6
8

169-000-336
169-000-337
169-000-338

$a^{+0.3}$

$b^{+0.2}$

c

3,1 5,0 0,3 ... 0,7
4,9 6,2 0,4 ... 0,9
6,9 6,2 0,5 ... 0,9

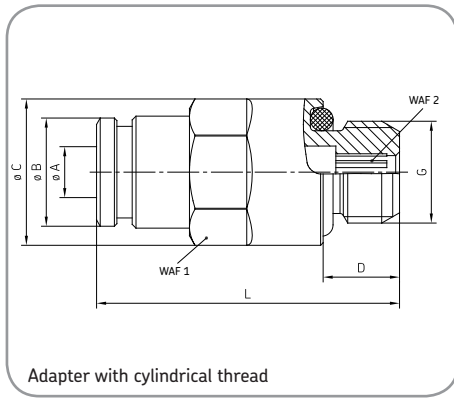

Adapter with cylindrical thread

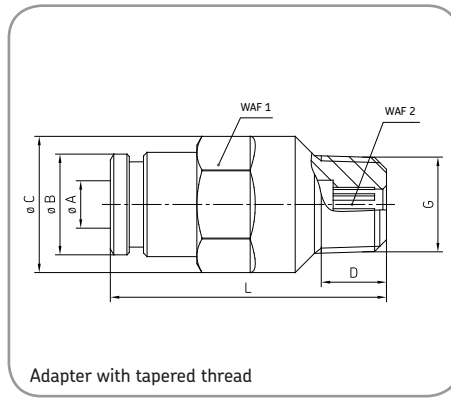

Adapter with tapered thread

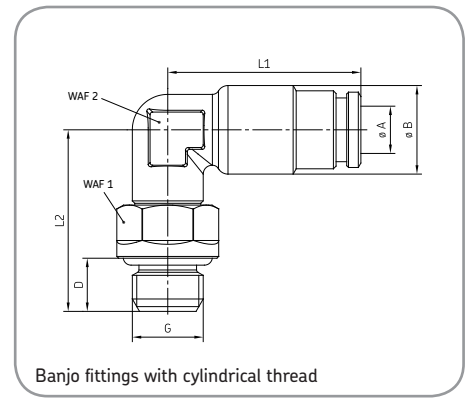

Banjo fittings with cylindrical thread

Ordering details (Adapters with cylindrical thread)

Order no.	Tube ØA	G	D	ØB	ØC	L	WAF 1	WAF 2	Seal
404-003-VS	4	M8 x 1	6	8,8	11,5	23,8	10	2,5	NBR
404-006-VS	4	M10 x 1	6	8,8	13,5	23,8	12	2,5	NBR
404-006-S8-VS	4	M10 x 1	6	8,8	13,5	23,8	12	2,5	FKM (FPM)
404-040-VS	4	G 1/8	6	8,8	13,5	23,8	12	2,5	NBR
406-158-VS	6	M8 x 1	6	11,7	13,2	30,5	12	3	NBR
406-004-VS	6	M10 x 1	6	11,7	13,5	27	12	4	NBR
406-004-S8-VS	6	M10 x 1	6	11,7	13,5	27	12	4	FKM (FPM)
456-004-VS	6	G 1/8	6	11,7	13,5	27	12	4	NBR
406-162-VS	6	M12 x 1	7	11,7	15,4	28	14	4	NBR
406-162-S8-VS	6	M12 x 1	7	11,7	15,4	28	14	4	FKM (FPM)
408-004-VS	8	M10 x 1	6	13,9	15,2	32,3	14	5	NBR
408-004-S8-VS	8	M10 x 1	6	13,9	15,2	32,3	14	5	FKM (FPM)
408-162-VS	8	M12 x 1	7	13,9	15,2	32,8	14	6	NBR
408-162-S8-VS	8	M12 x 1	7	13,9	15,2	32,8	14	6	FKM (FPM)

Ordering details (Adapters with tapered thread)

Order no.	Tube ØA	G	D	ØB	ØC	L	WAF 1	WAF 2
451-004-462-VS	4	M6 tap.	5,5	8	11	25,8	10	2,5
451-004-498-VS	4	M8 x 1 tap.	5	8,8	11,5	23,3	10	2,5
451-004-518-VS	4	M10 x 1 tap.	5,5	8,8	11,5	22,8	10	2,5
404-673K-V1-VS	4	1/4 - 28 SAE LT	5,1	8,8	11,5	26,3	10	2,5
404-040K-V1-VS	4	1/8 NPTF	8	8,8	11,5	24,8	10	2,5
451-006-468-VS	6	M6 tap.	5,5	11,7	13,5	30	12	2,5
451-006-498-VS	6	M8 x 1 tap.	5,5	11,7	13,5	29,5	12	4
451-006-518-VS	6	M10 x 1 tap.	5,5	11,7	13,5	27	12	4
406-423W-VS	6	R 1/8 tap.	6,5	11,7	13,5	28,5	12	4

Ordering details (Banjo fittings with cylindrical thread)

Order no.	Tube ØA	G	D	ØB	L1	L2	WAF 1	WAF 2	Seal
504-101-VS	4	M8 x 1	6	10	21,8	20,5	10	9	NBR
504-102-VS	4	M10 x 1	6	10	21,8	20,5	12	9	NBR
504-108-VS	4	G 1/8	6	10	21,8	20,5	12	9	NBR
506-139-VS	6	M8 x 1	6	12,5	26	21	10	10	NBR
506-140-VS	6	M10 x 1	6	12,5	26	21	12	10	NBR
506-140-S8-VS	6	M10 x 1	6	12,5	26	21	10	10	FKM (FPM)
506-108-VS	6	G 1/8	6	12,5	26	21	12	10	NBR
506-142-VS	6	M12 x 1	7	12,5	26	23	14	10	NBR
506-142-S8-VS	6	M12 x 1	7	12,5	26	23	14	10	FKM (FPM)
508-142-VS	8	M12 x 1	7	14,5	28,8	23	14	12	NBR
508-142-S8-VS	8	M12 x 1	7	14,5	28,8	23	14	12	FKM (FPM)

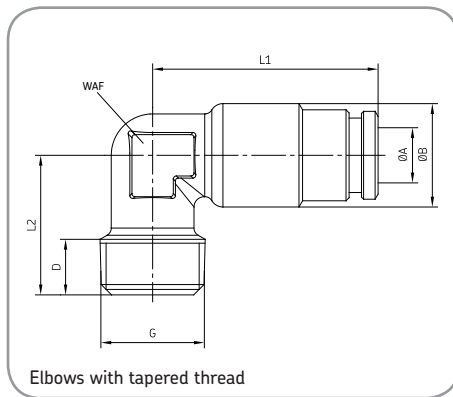
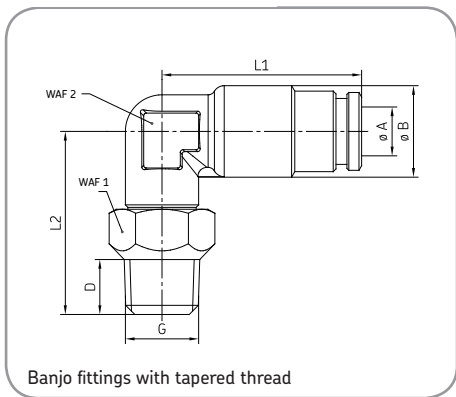

Ordering details (Banjo fittings with tapered thread)

Order no.	Tube ØA	G	D	ØB	L1	L2	WAF 1	WAF 2
455-546-048-VS	4	M6 tap.	6	10	21,8	20	10	9
455-529-048-VS	4	M8 x 1 tap.	6	10	21,8	20	10	9
455-531-048-VS	4	M10 x 1 tap.	6	10	21,8	20	12	9
455-529-068-VS	6	M8 x 1 tap.	6	12,5	26	20	10	10
455-531-068-VS	6	M10 x 1 tap.	6	12,5	26	20,5	12	10

Ordering details (Elbows with tapered thread)

Order no.	Tube ØA	G	D	ØB	L1	L2	WAF
453-004-471-VS	4	M6 tap.	6	10	21,8	14	9
504-201-VS	4	M8 x 1 tap.	6	10	21,8	13,5	9
504-202-VS	4	M10 x 1 tap.	6	10	21,8	13,5	9
514-018-VS	4	R 1/8 tap.	7,5	10	21,8	15	9
504-200K-V1-VS	4	1/4 - 28 SAE LT	5,1	10	21,8	15,5	9
514-018K-V1-VS	4	1/8 NPTF	7	10	21,8	15	9
453-006-468-VS	6	M6 tap.	6	12,5	26	15	10
506-508-VS	6	M8 x 1 tap.	6,5	12,5	26	14	10
506-510-VS	6	M10 x 1 tap.	6	12,5	26	14	10
508-511-VS	6	R 1/8 tap.	8,5	14,5	26	16,5	10

Fittings and accessories

Steel and plastic tubing

Ordering details (Steel tubing)

Order no.	Ø da ±0.05	s ±0.03	Minimum bending radius r		Design pressure [bar]	Burst pressure [bar]
			Bent with mandrel	Bent with grooved disk		
WV-R02.5x0.5 VERZI	2.5	0,5	5	-	580	1410
WV-R04x0.7 VERZI	4	0,7	8	7	500	1220
WV-R06x0.7 VERZI	6	0,7	25	12	320	850
WV-R08x0.7 VERZI	8	0,7	46	19	230	675
WV-R010x1 VERZI	10*	1	76	27	270	660

* Øda ± 0.07

VERZI = 25 µm galvanization – yellow passivated. Length delivered 5 m. Stainless steel tubing on request.

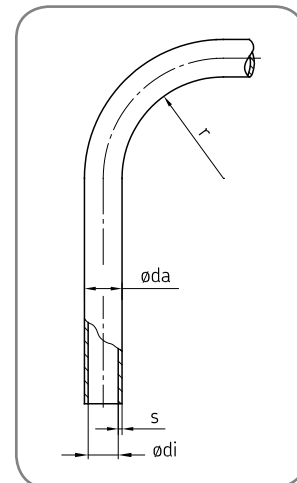

Ordering details (Plastic tubing)

Order no. ¹⁾	Ø da	s	Ø di +0.15 -0.05	Smallest permissible bending radius r bent		Perm. operating pressure ³⁾ [bar]	Burst pressure [bar]
				free-hand	with fixture ²⁾		
WVN715-R02.5x0.5	2.5	0,5	1,5	25	9	66	198
WVN715-R04x0.85	4	0,85	2,3	38	14	72	216
WVN715-R06x1	6 (±0,1)	1	4	63	21	53	159
WVN715-R06x1.25	6	1,25	3,5	63	21	70	210
WVN715-R08x1.25	8	1,25	5,5	76	28	49	147
WVN715-R010x1.5	10	1,5	7	89	35	47	141
WVN715-R012x1	12 (±0,15)	1	10	110	45	24	72
WVN715-R012x1.5	12	1,5	9	110	45	38	114
WVN716-R04x0.85	4	0,85	2,3	38	14	36	108
WVN716-R06x1.25	6 (±0,1)	1,25	3,5	63	21	35	105
WVN716-R08x1.25	8	1,25	5,5	80	30	25	75

Plastic tubing:

WVN715, without plasticizer
WVN716, flexible
(containing plasticizer)

Color: natural colors, black lettering.
Tubing available in green, red, black or brown on request. Tubing with other dimensions or also filled with NLGI grade 2 grease or fluid grease on request.

Important! For screwed tubing joints, only use unions with reinforcing sockets.

Material WVN715:

optionally polyamide 11 (PA 11) without plasticizer or polyamide 12 (PA 12) without plasticizer to DIN 73378.
PA 12 H: polyamide 12 without plasticizer, stabilized against thermal aging. (black tubing) PA 12 HL: polyamide 12 without plasticizer, stabilized against light-related and thermal aging.

Material WVN716:

optionally polyamide 11 (PA 11) flexible or polyamide 12 (PA 12) flexible to DIN 73378. PA 12 PH: polyamide 12 with plasticizer, stabilized against thermal aging. (black tubing) PA 12 PHL: polyamide 12 with plasticizer, stabilized against light-related and thermal aging.

Material properties:

Very good resistance and insensitivity to oils, greases, lubricants, all fuels, chlorine-free detergents and solvents. At room temperature good resistance to diluted mineral acids, organic acids, bases and saline solutions ⁴⁾. Inappropriate for concentrated mineral acids, concentrated acetic acid, phenols, cresols, chlorinated hydrocarbons, chlorine, acetones and ketones.

Permissible operating temperature:

approximately -60 to +80 °C
(-76 to +176 °F)

¹⁾ The desired length. e.g. 50 meters, has to be added to the order No.

Ordering example:

WVN716-R06x1.25x50M

²⁾ These minimal radii can be produced with the help of appropriate bending devices. The tubing has to be heated to 150 °C (300 °F) for this purpose - maximum duration of heating is 20 seconds.

³⁾ The operating pressures were ascertained in keeping with DIN 73378 to the formula

$$P = \frac{20 \cdot \sigma_V \cdot s \text{ (rated)}}{dm}$$

s = rated wall thickness [mm];
dm = da - s;
 σ_V = reference tension N/mm² at 23 °C (73 °F)

At higher temperatures, the pressure drops in keeping with the pressure efficiency as per DIN 73378.

Temperature range [°C / °F]	Pressure efficiency [%]
up to 30 °C / 86 °F	83
up to 40 °C / 104 °F	72
up to 50 °C / 122 °F	64
up to 60 °C / 140 °F	57
up to 70 °C / 158 °F	52
up to 80 °C / 176 °F	47

⁴⁾ In complex cases, consult SKF before ordering.

High pressure hoses for self-installation

(Operating pressure: 325 bar / 130 bar)

For main lines (connection: pump-feeder) and secondary lines (connection: feeder-lubrication point)

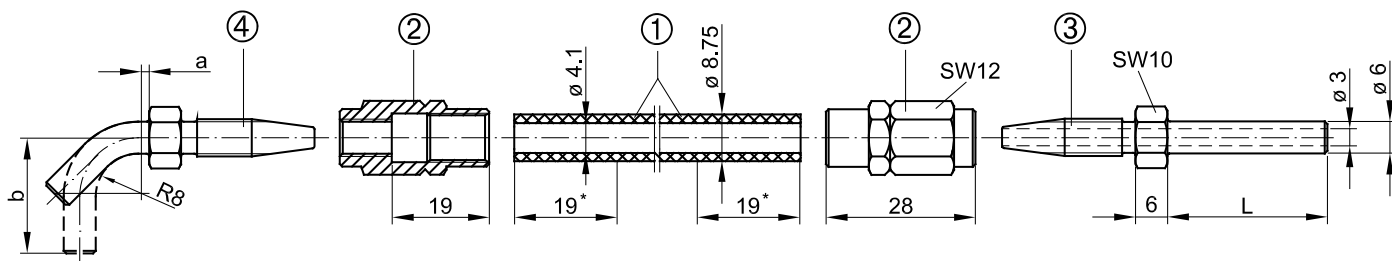

* Take length of engaged thread into account twice when determining the length of the hose.

Ordering details

Order no.	Designation	L	a	b
982-750-091-20M	1. High press. hose, length supplied 20 m			
982-750-091+AF2-20M	1. High press. hose, length supplied 20 m filled with NLGI grade 2 grease			
853-540-010	2. Sleeve			
853-370-002(-VS) ¹⁾	3. Tube stud, straight	20		
853-380-002(-VS) ¹⁾		30		
853-390-002(-VS) ¹⁾		66		
853-380-003(-VS) ¹⁾	4. Tube stud, 45° angle			
853-380-003(-VS) ¹⁾	4. Tube stud, 90° angle		2	21
853-390-003(-VS) ¹⁾			13	47

¹⁾ Version with claw groove on ends of tubing for SKF quick connectors, order no. ... -VS

Electric plug-and-socket connectors

Sockets for pressure switches, level switches, flow sensors, directional control valves and filters

Electric plugs or sockets are required for the actuation of various models of hydraulic equipment used in the field of central lubrication technology and for the evaluation of switching signals.



Ordering details									
Order no.	Standard design/type	Application							
		Pressure switch	Flow sensor	Filter monitor	Lubricant level switch	Piston distributor	Oil-streak sensor	Flow monitor	Cycle switch
179-990-034	DIN EN 175301-803/ ISO4400	•	•	•	•				
179-990-371 straight 179-990-372 angled	4-pole type, M12 x 1	•	•	•	•	•	•	•	•
179-990-600 straight 179-990-601 angled	4-pole type, M12 x 1 (with integrally extruded line)	•	•	•	•	•	•	•	•

Socket

To DIN EN 175301-803/ISO 4400
supplied with flat packing and fixing screw

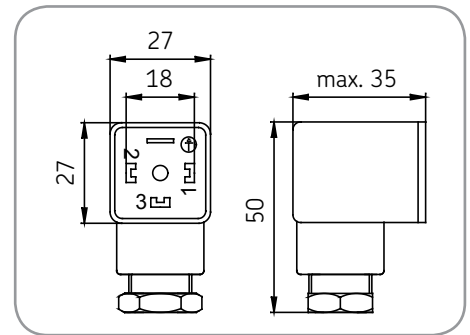
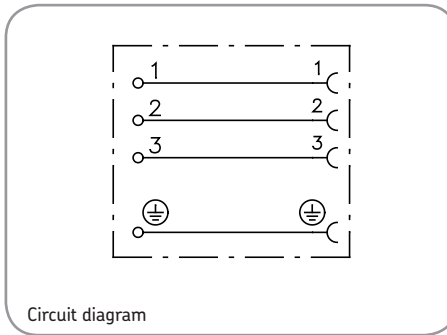

Ordering details			
Order no. 179-990-034			
Version	Insert rotatable 4 x 90°	Cable gland	PG 11 / PG 9°
Poles	3 + PE	Conductor cross section	max. 1,5 mm ²
Operating display	-	Line diameter	6 to 9 mm / 4,5 to 7 mm
Maximum rated operating voltage	230 V AC/DC	Type of terminal	Screws
Maximum operating current	10 A	IP enclosure DIN 40050	IP 65 (installed)
Housing	PA, black	Temperature range	-40 to +80 °C
Approval	UL-SEV	Seal	Attached, NBR

* PG = heavy gauge conduit thread

Socket M12 x 1



Type A straight

Type B angled

Type C straight

Type D angled

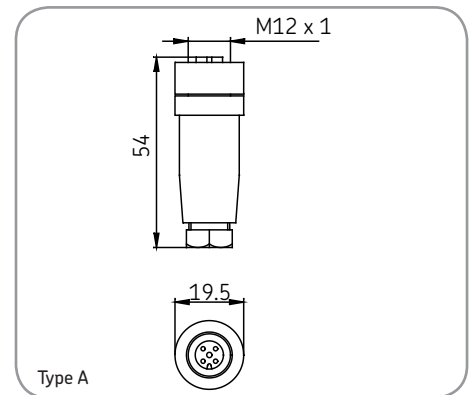

Type A

Ordering details

Order no.	179-990-371 / 179-990-372	179-990-600 / 179-990-601
Version	A / B	C / D
Poles	4	4
Maximum rated operating voltage	0 to 30 V AC/DC	10 to 30 V AC/DC
Maximum operating current	3 A	4 A
Housing	PBT-GF, black / PA, black	-
Approval	-	UL-CSA
Conductor cross section	Max. 0,75 mm ²	-
Line diameter	4 to 6 mm	5 mm
Type of terminal	Screws	-
Power lead	-	5 m (4 x 0,25 mm ²) PUR / PVC
Color coding	-	cf. circuit diagram
IP enclosure DIN 40050	IP 67 (installed)	IP 68 (installed)
Temperature range	-40 to +85 °C	-25 to +90 °C
Seal material (O-ring)	Integrated	Integrated, FKM (FPM)

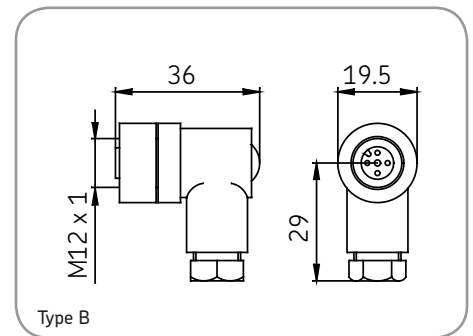

Type B

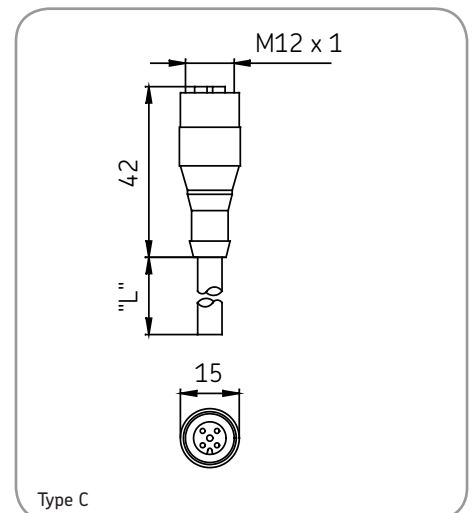

Type C

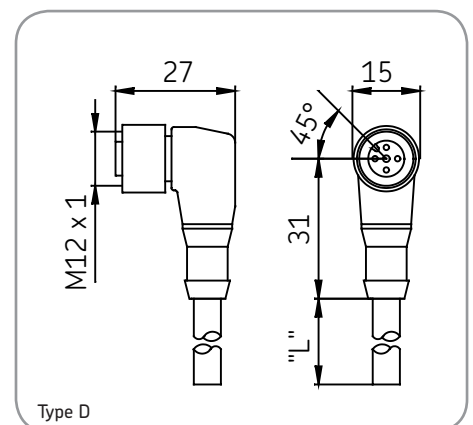

Type D

Contact assignments
(Viewing the plug side)

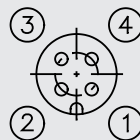
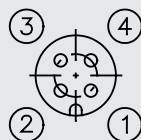

Circuit diagram

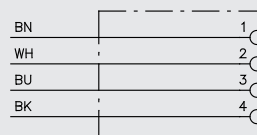
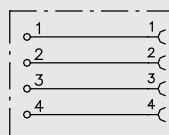

Oil Check Monitor TMEH 1

Detects changes in oil condition

The OilCheck measures the changes in dielectric constant of an oil.

By comparing the measurements obtained from used and unused oils of the same type and brand, the SKF OilCheck is able to determine the degree of change in the condition of the oil. Dielectric change is directly related to the degradation and contamination level of the oil and will allow the user to achieve optimized intervals between oil changes and detect increased mechanical wear and loss of the oils lubricating properties. To facilitate trending, the instrument is equipped with a numerical read-out.

Important

The SKF OilCheck is not an analytical instrument. It is an instrument to detect only changes in the oil condition. The visual and numerical read-outs are purely a guide to enable trending of the comparative readings of a good oil to a used oil of the same type and brand. Do not rely solely on numerical readings.

- Shows changes in oil condition affected by such things as:
 - Water content
 - Fuel contamination
 - Metallic content
 - Oxidation
- Hand-held and user friendly
- Numerical read-out to facilitate trending



Handheld Viscometer TMVM 1

Reduce costly and time consuming laboratory analyses

The SKF viscometer TMVM 1 is a handheld rotational viscometer for quick and reliable viscosity measurements of lubrication oils and hydraulic fluids. It is suitable for both quantitative and qualitative measurements.

The TMVM 1 is a first check device for carrying out on-site measurements. Regular viscosity checks help provide timely information regarding oil condition, which can have an effect on lubrication and machine performance.

- Compact light-weight design and portability of the viscometer make it an essential device for field service engineers and other field operators
- Supplied standard with a rotor suitable for a viscosity range between 30 and 1 300 MPas covering a majority of lubrication oils
- Ergonomic design makes it easy to operate with one hand

- Direct read out eliminates the need for further complex, time-consuming calculations
- Use of supplied measuring cup helps ensure reproducible measuring conditions for accurate measurements
- Excellent repeatability allowing reliable trending of oil condition
- Recalibration message displayed on the viscometer allows timely recalibration
- Alternative rotors available as accessories make viscosity measurement of other fluids possible
- Battery (4 × AA alkaline) operated, does not require a main electrical supply making it a convenient instrument for field tests
- Supplied in a sturdy carrying case for ease of portability



Oil Safe

Help reduce contamination and decrease operating costs

The Oil Safe range of products are ideal for the storage and administration of fluids and oil lubricants. Oil Safe consists of various size drums and dispensing lids, which are fully interchangeable to meet the customer's specific lubrication requirements. The lids are available in

ten different colors to help in creating a color-coded system. There are five different lids (three with incorporated spout), five different size drums ranging from 1,5 to 10 liters (1.6 to 10.5 quarts).

In addition, there are two different spout hose attachments and one pump that can be used with the Oil Safe utility lid.

Features

- The unique 'O' ring sealing, twist spout and lid design, keeps rain, dust and other contaminants out. This helps reduce the chance of damage to plant machinery by the use of contaminated lubricants
- Containers are heat and chemical resistant and contain UV radiation stabilizers and anti-static agents
- Products are durable and the contents are protected from environmental damage even in the harshest conditions
- Manufactured from HDPE (High Density Polyethylene) grade polymers which help prevent rust and make products suitable for indoor and outdoor use
- Lids come in ten different colors allowing different colors to be used for different oils. Color-coded labels are also available to identify the contents
- Drums all have wide-mouth openings which allows for fast, non-spill filling from bulk sources
- Drums are compact (1½, 2, 3, 5 and 10 liter), and ergonomically designed making the product easier to lift and carry
- Drums are see-through and have measuring scales so that fluids and oil lubricant levels are easy to measure and contaminants can easily be seen



Ordering details

Designation	Description	Designation	Description	Designation	Description
LAOS 09224	Oil Safe 1.5 liter drum	LAOS 09682	Stretch spout lid tan	LAOS 09101	Mini spout lid dark green
LAOS 63571	Oil Safe 2 liter drum	LAOS 09699	Stretch spout lid grey	LAOS 09118	Mini spout lid green
LAOS 63595	Oil Safe 3 liter drum	LAOS 09798	Stretch spout lid orange	LAOS 09125	Mini spout lid blue
LAOS 63618	Oil Safe 5 liter drum	LAOS 09804	Stretch spout lid black	LAOS 09132	Mini spout lid red
LAOS 66251	Oil Safe 10 liter drum	LAOS 09811	Stretch spout lid dark green	LAOS 09194	Mini spout lid yellow
LAOS 09644	Oil Safe storage lid tan	LAOS 09828	Stretch spout lid green	LAOS 09071	Mini spout lid purple
LAOS 09651	Oil Safe storage lid grey	LAOS 09835	Stretch spout lid blue	LAOS 06919	Contents label tan
LAOS 09934	Oil Safe storage lid orange	LAOS 09842	Stretch spout lid red	LAOS 06964	Contents label grey
LAOS 09941	Oil Safe storage lid black	LAOS 09392	Stretch spout lid purple	LAOS 06940	Contents label orange
LAOS 09958	Oil Safe storage lid dark green	LAOS 62437	Stretch spout lid yellow	LAOS 06995	Contents label black
LAOS 09965	Oil Safe storage lid green	LAOS 09705	Stumpy spout lid tan	LAOS 06971	Contents label dark green
LAOS 09972	Oil Safe storage lid blue	LAOS 09712	Stumpy spout lid grey	LAOS 06957	Contents label green
LAOS 09989	Oil Safe storage lid red	LAOS 09729	Stumpy spout lid orange	LAOS 06988	Contents label blue
LAOS 09415	Oil Safe storage lid purple	LAOS 09736	Stumpy spout lid black	LAOS 06926	Contents label red
LAOS 62475	Oil Safe storage lid yellow	LAOS 09743	Stumpy spout lid dark green	LAOS 06902	Contents label yellow
LAOS 09668	Utility lid tan	LAOS 09750	Stumpy spout lid green	LAOS 06933	Contents label purple
LAOS 09675	Utility lid grey	LAOS 09767	Stumpy spout lid blue	LAOS 09422	Pump reducer nozzle
LAOS 09866	Utility lid orange	LAOS 09774	Stumpy spout lid red	LAOS 67265	Stumpy spout hose extension
LAOS 09873	Utility lid black	LAOS 09388	Stumpy spout lid purple	LAOS 62499	Stretch spout hose extension
LAOS 09880	Utility lid dark green	LAOS 64936	Stumpy spout lid yellow	LAOS 62567	Pump (to fit Oil Safe utility cans)
LAOS 09897	Utility lid green	LAOS 09057	Mini spout lid tan		
LAOS 09903	Utility lid blue	LAOS 09064	Mini spout lid grey		
LAOS 09910	Utility lid red	LAOS 09088	Mini spout lid orange		
LAOS 09408	Utility lid purple	LAOS 09095	Mini spout lid black		
LAOS 62451	Utility lid yellow				

Technical data

TMBA G11D (page 93)

Designation	TMBA G11D
Pack size	50 pairs
Size	9
Color	blue

LAGF series (page 92)

Designation	LAGF 18	LAGF 50
Maximum pressure	30 bar (430 psi)	30 bar (430 psi)
Volume / stroke	Approximately 45 cm ³ (1.5 fl oz.)	Approximately 45 cm ³ (1.5 fl oz.)
Suitable drum dimensions:		
- Inside diameter	265 - 285 mm (10.4 - 11.2 in)	350 - 385 mm (13.8 - 15.2 in)
- Maximum inside height	420 mm (16.5 in)	675 mm (26.6 in)
Weight	5 kg (11 lb)	7 kg (15 lb)

LAGG series (page 92)

Designation	LAGG 18M	LAGG 18AE	LAGG 50AE	LAGG 180AE	LAGT 180
Description	Grease pump for 18 kg drums	Mobile grease pump for 18 kg drums	Grease pump for 50 kg drums	Grease pump for 180 kg drums	Trolley for drums up to 200 kg
Pumping	Manual	Air-pressure	Air-pressure	Air-pressure	-
Maximum pressure	500 bar (7 250 psi)	420 bar (6 090 psi)	420 bar (6 090 psi)	420 bar (6 090 psi)	-
SKF Drum	18 kg (39.6 lb)	18 kg (39.6 lb)	50 kg (110 lb)	180 kg (396 lb)	180 kg (396 lb)
Inner diameter	265 - 285 mm (10.43 - 11.22 in)	265 - 285 mm (10.43 - 11.22 in)	350 - 385 mm (13.78 - 15.16 in)	550 - 590 mm (21.65 - 23.23 in)	-
Note	Stationary	Mobile	Stationary	Stationary	Mobile
Volume / stroke	1,6 cc	-	-	-	-
Volume / minimum	-	200 cc	200 cc	200 cc	-
Suitable grease					
NLGI class	000 - 2	0 - 2	0 - 2	0 - 2	-

LAGN 120 (page 93)

Designation	LAGN 120		
Maximum working pressure	400 bar (5 800 psi)	Standard	DIN 71412
Minimum burst pressure	800 bar (11 600 psi)	Material	Hardened steel

Quick connectors (page 94)

Maximum operating pressure	300 bar (metal tube with claw groove)
Maximum operating temperature	-40 to 80 °C
Medium	Oils, grease up to NGLI grade 2
Connection	Detachable
Material	Brass

Suitable for steel tubing with claw groove and for plastic tubing

High pressure hoses for self-installation (page 98)

Hose	
Operating pressure	325 bar
Burst pressure	800 bar
Minimum bending radius	35 mm
Materials	
Hose	Inner lining: unplasticized polyester Liner layer: braided synthetic fibers Outer cover: weatherproof polyurethane steel, galvanized
Sleeve, tube stud:	

TMEH 1 (page 101)

Designation	TMEH 1		
Suitable oil types	Mineral and synthetic oils	Battery	9V alkaline IEC 6LR61
Repeatability	Better than 5%	Battery lifetime	> 150 hours or 3 000 tests
Read-out	Green / red grading + numerical value (0 - 100)	Dimensions	250 × 95 × 32 mm (instrument) (9.8 × 3.7 × 1.3 in)

TMVM 1 (page 101)

Designation	TMVM 1
Description	Handheld viscometer
Dynamic viscosity range (MPas)	30 - 1 300 with Rotor 3 (30 - 400 000 using optional rotors)
Motor rated voltage	4,0 VD C
Motor rated speed	62,5 rpm
Rotor supplied	R3
Repeatability	< 1 % of total range
Accuracy	± 3 % of total range with supplied rotor R3
Operating temperature	10 to 40 °C (50 to 104 °F)
Oil sample volume	Approx. 150 ml (5.1 fl.oz.)
Viscometer dimension (w × d × h)	175 × 88 × 170 mm (6.8 × 3.4 × 6.6 in)
Rotor dimension	D = 45,1 mm (1.7 in) h = 47 mm (1.8 in)
Rotor material	Stainless steel
Measuring cup dimension	D = 52,6 mm (2.0 in) h = 75 mm (2.9in)
Measuring cup material	Stainless steel
Battery	4 × AA (IEC type LR06) alkaline
Total weight (including case)	2,0 kg (4.4 lbs)
Packaging	Sturdy carrying case
Certificate of calibration	Yes

© SKF, SYSTEM 24, MonoFlex, DuoFlex, MultiFlex, LubriLean, VectoLub, WindLub, EasyRail and DosaLub are registered trademarks of the SKF Group.
Oil Safe is a registered trademark of Oil Safe Systems Pty Ltd.

© SKF Group 2009

The contents of this publication are the copyright of the publisher and may not be reproduced (even extracts) unless prior written permission is granted. Every care has been taken to ensure the accuracy of the information contained in this publication but no liability can be accepted for any loss or damage whether direct, indirect or consequential arising out of the use of the information contained herein.

Printed in The Netherlands on environmentally friendly paper.
Certain image(s) used under license from Shutterstock.com.



Important product usage information

All products from SKF may be used only for their intended purpose as described in this brochure and in any instructions. If operating instructions are supplied with the products, they must be read and followed.

Not all lubricants are suitable for use in centralized lubrication systems. SKF does offer an inspection service to test customer supplied lubricant to determine if it can be used in a centralized system. SKF lubrication systems or their components are not approved for use with gases, liquefied gases, pressurized gases in solution and fluids with a vapor pressure exceeding normal atmospheric pressure (1013 mbars) by more than 0,5 bar at their maximum permissible temperature.

Hazardous materials of any kind, especially the materials classified as hazardous by European Community Directive EC 67/548/EEC, Article 2, Par. 2, may only be used to fill SKF centralized lubrication systems and components and delivered and/or distributed with the same after consulting with and receiving written approval from SKF.