

Industrial shaft seals



SI conversion table

Quantity	Unit	Conversion			
Length	inch	1 mm	0.039 in.	1 in.	25,40 mm
	foot	1 m	3.281 ft.	1 ft.	0,3048 m
	yard	1 m	1.094 yd.	1 yd.	0,9144 m
	mile	1 km	0.6214 mile	1 mile	1,609 km
Velocity, speed	foot per second	1 m/s	3.28 ft/s	1 ft/s	0,30480 m/s
	foot per minute	1 m/s	196.8504 ft/min	1 ft/min	0,00508 m/s
	mile per hour	1 km/h	0.6214 mile/h (mph)	1 mile/h (mph)	1,609 km/h
Force	pound-force	1 N	0.225 lbf.	1 lbf.	4,4482 N
Pressure, stress	pounds per square inch	1 MPa	145 psi	1 psi	6,8948 × 10 ³ Pa
Temperature	° (degree)	Celsius	$t_C = 0,555 (t_F - 32)$	Fahrenheit	$t_F = 1,8 t_C + 32$

© SKF, CR, DURATEMP, SPEEDI-SLEEVE and WAVE are registered trademarks of the SKF Group.

© SKF Group 2010

The contents of this publication are the copyright of the publisher and may not be reproduced (even extracts) unless prior written permission is granted. Every care has been taken to ensure the accuracy of the information contained in this publication but no liability can be accepted for any loss or damage whether direct, indirect or consequential arising out of the use of the information contained herein.

The data in this publication may differ from that provided in earlier publications because of redesign, technological developments or revised methods of calculation. SKF reserves the right to make continuing improvements to SKF products without prior notice with respect to materials, design and manufacturing methods, as well as changes necessitated by technological developments.

PUB SE/P1 10919 EN · July 2010

This publication supersedes publication 5300.

Printed in Sweden on environmentally friendly paper.

1	Product data – general.....	11	1
2	Radial shaft seals.....	47	2
3	Cassette seals.....	325	3
4	Wear sleeves.....	331	4
5	Track pin seals.....	377	5
6	Metal face seals.....	383	6
7	V-ring seals.....	393	7
8	Axial clamp seals.....	467	8
9	Product index.....	478	9

Contents

Foreword	5	2 Radial shaft seals	47
SKF – the knowledge engineering company	6	General	50
SKF industrial shaft seals and accessories	10	Outside diameter design	54
SKF Bore Tite Coating		SKF Bore Tite Coating	54
1 Product data – general	11	Garter springs	55
Industrial shaft seals	12	Dimensions	55
Profile overview selection	13	Tolerances	55
Radial shaft seals	13	Sealing lip design	57
Wear sleeves	15	Auxiliary lips	58
Axial shaft seals	16	Coaxiality and runout	59
Selection of seal design and material	17	Coaxiality	59
Grease retention	17	Runout	61
Oil retention	18	Axial movement	63
Contaminant exclusion	19	Permissible speeds	63
Retention and exclusion	20	Lubrication	65
Separating two liquids	21	Lubrication of paired arrangements ..	65
Circumferential and rotational speed	22	Friction	66
Pressure differentials	23	Chemical and thermal resistance	67
Limited space	24	Seals under pressure	69
Installation restrictions	25	Shaft requirements	70
Arrangement	26	General	70
Counterface design	27	Tolerances	70
Axial movement	28	Surface roughness	70
Seal materials	29	Surface finish	72
Cases and inserts	29	Hardness and surface treatment	72
Garter springs	29	Lead-in chamfers	72
SKF Bore Tite Coating	29	Housing bore requirements	74
Adhesives and bonding agents	29	General	74
Sealing lip materials	30	Tolerances	76
Wear resistance	33	Surface roughness	76
Operating temperatures	34	Seal installation, general industrial applications	77
Chemical resistance	35	General	77
Storage and handling of seals	44	Seal installation, heavy industrial applications	79
General	44	Metal-reinforced seals	79
Storage	44	Seals without metal reinforcement ..	80
Cleaning and maintenance	45	Split seals	80
		Cover plates	82
		Multiple HS seal installations	83
		Multiple HDS seal installations	84
		PTFE seals	85
		Protecting the counterface surface against corrosion	87
		Removal	87
		Replacement	87
		Designation system	88
		Metric radial shaft seals	88
		Inch-size radial shaft seals	88
		Assortment and availability	88
		Seals for general industrial applications	92
		HMS5 and HMSA10 seals	92

CRW1, CRWA1, CRWH1 and CRWHA1 seals	100	6 Metal face seals	383
CRW5 and CRWA5 seals	156	General	384
HDW1 seals	160	Design features	384
HMS4 and HMSA7 seals	162	Lubricant requirements	385
CRS1, CRSH1, CRSA1 and CRSHA1 seals	170	Permissible operating conditions	386
PTFE radial shaft seals	178	Contaminants	386
HM and TL seals for grease lubricated applications	182	Installing HDDF seals	386
X seals, sealing against housing bore	196	General	386
Seals for heavy industrial applications	206	Housing and seal preparation	386
General	206	Installation procedure	387
Metal-cased seals	206	Product tables	388
Rubber outside diameter seals	211		
Additional design features	215	7 V-ring seals	393
Size options of metal-cased HDS seals and all-rubber HS seals	219	General	394
Product tables	220	Features	394
		Materials	395
3 Cassette seals	325	Standard designs	396
General	326	Main V-ring functions	397
Design features	327	Other V-ring functions	398
Testing	327	Sliding velocities	399
Installation	327	Coaxiality and runout	400
SKF Mudblock seal designs		Misalignment	400
MUD5 and MUD7	328	Counterface	401
		Counterface treatment	401
4 Wear sleeves	331	Additional counterface information	401
General	332	Shaft requirements	403
SKF SPEEDI-SLEEVE	333	Installing V-rings	403
Features	333	Product tables	404
Size range	333	MVR axial shaft seals	460
SKF SPEEDI-SLEEVE Gold	334	General	460
Choosing the right size	334	Advantages and user benefits	460
Installing SKF SPEEDI-SLEEVE	335	Design and material	460
Removing SKF SPEEDI-SLEEVE	337	Temperature range	460
Product tables	338	Sizes	460
		Installation	461
Wear sleeves for heavy industrial applications (LDSLV)	360	Product tables	462
General	360		
Designs and features	361	8 Axial clamp seals	467
Using LDSLV designs	362	General	468
Installation	362	Designs	468
Removal	362	Design of the sealing arrangement	469
Product tables	364	Installation instructions	470
		Product tables	472
5 Track pin seals	377		
General	378	9 Product index	478
Features and benefits	378		
Product tables	380		



The SKF brand now stands for more than ever before, and means more to you as a valued customer.

While SKF maintains its leadership as a high-quality bearing manufacturer throughout the world, new dimensions in technical advances, product support and services have evolved SKF into a truly solutions-oriented supplier, creating greater value for customers.

These solutions enable customers to improve productivity, not only with breakthrough application-specific products, but also through leading-edge design simulation tools and consultancy services, plant asset efficiency maintenance programmes, and the industry's most advanced supply management techniques.

The SKF brand still stands for the very best in rolling bearings, but it now stands for much more.

SKF – the knowledge engineering company

Foreword

This edition of the Industrial shaft seals catalogue supersedes the one published in 2006 (publication number 5300). For this new edition, numerous revisions, additions and enhancements have been made to provide an even more comprehensive guide. Though the aim of this catalogue is to cover a very wide seal assortment, it still only includes a selection of our complete assortment of shaft seals and accessories.

The data in this catalogue may differ from that provided in earlier catalogues because of redesign, technological developments or revised methods of calculation. SKF reserves the right to make continuing improvements to SKF products without prior notice with respect to materials, design and manufacturing methods, as well as changes necessitated by technological developments.

Catalogue overview

In order to emphasize the importance of studying the operating conditions of each application before selecting a sealing solution, this catalogue outlines the most important factors to consider. These are provided in the chapter *Product data – general*, along with basic shaft and housing bore requirements.

SKF industrial shaft seals and accessories are divided into three main groups: radial shaft seals, axial shaft seals and wear sleeves. Different seal types within these groups are described with their respective design, materials and applications.

Product descriptions are followed by product tables. It should be noted, however, that these tables only cover a selection of available sizes. Always contact your SKF sales representative for complete and updated availability information.

The SKF Interactive Engineering Catalogue

SKF provides this catalogue in electronic format, the *SKF Interactive Engineering Catalogue*, online at www.skf.com.

Units

The units in this catalogue are in accordance with ISO (International Organization for Standardization) standard 1000:1992, and SI (Système International d'Unités).

SKF – the knowledge engineering company

From the company that invented the self-aligning ball bearing more than 100 years ago, SKF has evolved into a knowledge engineering company that is able to draw on five technology platforms to create unique solutions for its customers. These platforms include bearings, bearing units and seals, of course, but extend to other areas including: lubricants and lubrication systems, critical for long bearing life in many applications; mechatronics that combine mechanical and electronics knowledge into systems for more effective linear motion and sensorized solutions; and a full range of services, from design and logistics support to condition monitoring and reliability systems.

Though the scope has broadened, SKF continues to maintain the world's leadership in the design, manufacture and marketing of rolling bearings, as well as complementary products such as radial seals. SKF also holds an increasingly important position in the market for linear motion products, high-precision aerospace bearings, machine tool spindles and plant maintenance services.

The SKF Group is globally certified to ISO 14001, the international standard for environmental management, as well as OHSAS 18001, the health and safety management standard. Individual divisions have been approved for quality certification in accordance with ISO 9001 and other customer specific requirements.

With over 100 manufacturing sites worldwide and sales companies in 70 countries, SKF is a truly international corporation. In addition, our 15 000 distributors and dealers around the world, an e-business marketplace, and a global distribution system, put SKF closer to customers to enhance their ability to quickly supply both products and services. In essence, SKF solutions are available wherever and whenever customers need them. Overall, the SKF brand and the corporation are stronger than ever. As the knowledge engineering company, we stand ready to serve you with world-class product competencies, intellectual resources, and the vision to help you succeed.

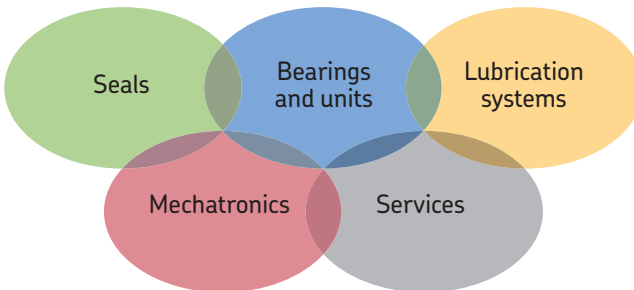



© Airbus – photo: emm company, H. Goussé

Evolving by-wire technology

SKF has a unique expertise in the fast-growing by-wire technology, from fly-by-wire, to drive-by-wire, to work-by-wire. SKF pioneered practical fly-by-wire technology and is a close working partner with all aerospace industry leaders. As an example, virtually all aircraft of the Airbus design use SKF by-wire systems for cockpit flight control.



SKF is also a leader in automotive by-wire technology, and has partnered with automotive engineers to develop two concept cars, which employ SKF mechatronics for steering and braking. Further by-wire development has led SKF to produce an all-electric forklift truck, which uses mechatronics rather than hydraulics for all controls.



Harnessing wind power

The growing industry of wind-generated electric power provides a source of clean, green electricity. SKF is working closely with global industry leaders to develop efficient and trouble-free turbines, providing a wide range of large, highly specialized bearings and condition monitoring systems to extend equipment life of wind farms located in even the most remote and inhospitable environments.



Working in extreme environments

In frigid winters, especially in northern countries, extreme sub-zero temperatures can cause bearings in railway axleboxes to seize due to lubrication starvation. SKF created a new family of synthetic lubricants formulated to retain their lubrication viscosity even at these extreme temperatures. SKF knowledge enables manufacturers and end user customers to overcome the performance issues resulting from extreme temperatures, whether hot or cold. For example, SKF products are at work in diverse environments such as baking ovens and instant freezing in food processing plants.



Developing a cleaner cleaner

The electric motor and its bearings are the heart of many household appliances. SKF works closely with appliance manufacturers to improve their products' performance, cut costs, reduce weight, and reduce energy consumption. A recent example of this cooperation is a new generation of vacuum cleaners with substantially more suction. SKF knowledge in the area of small bearing technology is also applied to manufacturers of power tools and office equipment.



Maintaining a 350 km/h R&D lab

In addition to SKF's renowned research and development facilities in Europe and the United States, Formula One car racing provides a unique environment for SKF to push the limits of bearing technology. For over 60 years, SKF products, engineering and knowledge have helped make Scuderia Ferrari a formidable force in F1 racing. (The average racing Ferrari utilizes around 150 SKF components.) Lessons learned here are applied to the products we provide to automakers and the aftermarket worldwide.



Delivering Asset Efficiency Optimization

Through SKF Reliability Systems, SKF provides a comprehensive range of asset efficiency products and services, from condition monitoring hardware and software to maintenance strategies, engineering assistance and machine reliability programmes. To optimize efficiency and boost productivity, some industrial facilities opt for an Integrated Maintenance Solution, in which SKF delivers all services under one fixed-fee, performance-based contract.



Planning for sustainable growth

By their very nature, bearings make a positive contribution to the natural environment, enabling machinery to operate more efficiently, consume less power, and require less lubrication. By raising the performance bar for our own products, SKF is enabling a new generation of high-efficiency products and equipment. With an eye to the future and the world we will leave to our children, the SKF Group policy on environment, health and safety, as well as the manufacturing techniques, are planned and implemented to help protect and preserve the earth's limited natural resources. We remain committed to sustainable, environmentally responsible growth.

SKF industrial shaft seals and accessories

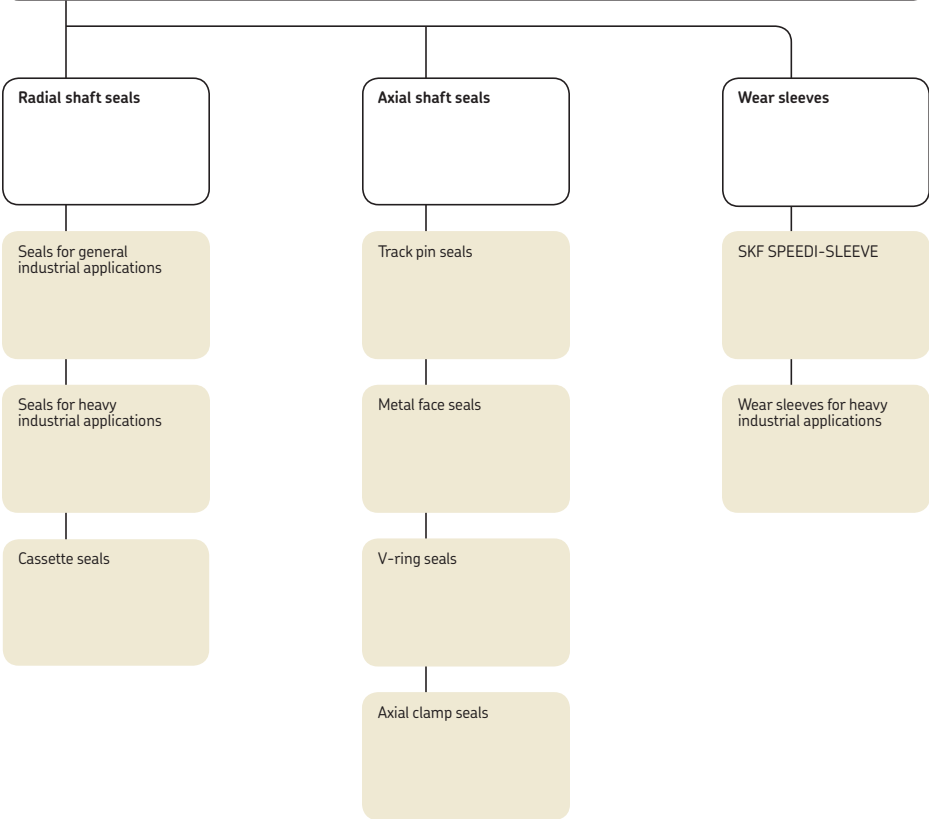

Product data – general

Industrial shaft seals	12
Profile overview selection	13
Radial shaft seals	13
Wear sleeves	15
Axial shaft seals	16
Selection of seal design and material	17
Grease retention	17
Oil retention	18
Contaminant exclusion	19
Retention and exclusion	20
Separating two liquids	21
Circumferential and rotational speed	22
Pressure differentials	23
Limited space	24
Installation restrictions	25
Arrangement	26
Counterface design	27
Axial movement	28
Seal materials	29
Cases and inserts	29
Garter springs	29
SKF Bore Tite Coating	29
Adhesives and bonding agents	29
Sealing lip materials	30
Wear resistance	33
Operating temperatures	34
Chemical resistance	35
Storage and handling of seals	44
General	44
Storage	44
Cleaning and maintenance	45

Industrial shaft seals

Industrial shaft seals are used to seal the opening between a rotating and a stationary component, or between two components in relative motion. Primary seal functions include:

- Retain the lubricant
- Exclude contaminants
- Separate two different media
- Seal under pressure

To be effective, industrial shaft seals should operate with a minimum of friction and wear, even under unfavourable operating conditions. In order to meet the requirements of a variety of different applications and operating conditions, SKF industrial shaft seals for rotating machine components are manufactured from many different designs, materials and executions. Each of these designs and material combinations has specific properties, making them suitable for a particular application. The main groups of shaft seals and accessories are:

Radial shaft seals

- Seals for general industrial applications
- Seals for heavy industrial applications
- Cassette seals

Axial shaft seals

- Track pin seals
- Metal face seals
- V-ring seals
- Axial clamp seals

Wear sleeves

- SKF SPEEDI-SLEEVE
- Wear sleeves for heavy industrial applications

Availability

The SKF assortment of industrial shaft seals comprises hundreds of different designs and material combinations. The products shown in this catalogue and listed in the product tables are the more commonly used seal types and sizes.

Guidance values

Since several factors simultaneously affect the sealing system and seal performance, all stated values in graphs and tables in this publication should be considered as guidelines only and not as absolute values for practical applications.

Profile overview selection

Radial shaft seals

Seals for general industrial applications, elastomeric sealing lip(s)



Seals for general industrial applications, PTFE sealing lip(s)



Seals for heavy industrial applications



Cassette seals, SKF Mudblock



Wear sleeves

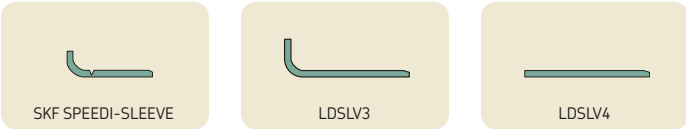

Product data – general

Axial shaft seals

Track pin seals, SKF Trackstar

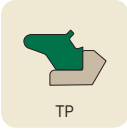

Metal face seals



V-ring seals



Axial clamp seals

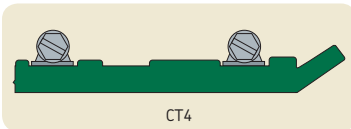
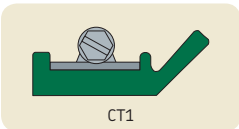
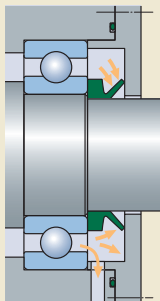

Fig. 1

V-ring



Selection of seal design and material

Selecting an appropriate seal design and material depends on the operating conditions of the application such as:

- temperature
- speed
- pressure differential
- type of lubricant
- vertical or horizontal orientation
- runout and shaft-to-bore misalignment

Because the influence of one operating condition typically dominates the seal selection process, there are no universal rules for determining the appropriate seal type or design for a given application. This section describes how operating conditions affect seal performance and service life and provides guidance on selecting the most appropriate seal for a given application.

Matrix 1 and 2 on **pages 90 to 91** and **202 to 205** list the standard SKF radial shaft seals and their main features and permissible operating conditions.

Fig. 2

HMS5 seal

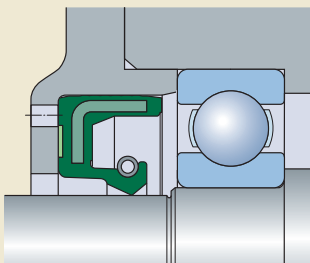

Grease retention

Greases have a relatively high viscosity and are relatively easy to retain in a bearing arrangement. In many grease lubricated applications, a non-spring-loaded sealing lip design or a V-ring can adequately retain the grease (→ **fig. 1**).

However, more demanding applications may require HMS5 or CWR1 spring-loaded radial shaft seals (→ **figs. 2 and 3**).

When frequent relubrication is required, the lip of at least one of the seals in the sealing arrangement should be directed toward the air side so that excess grease can escape via the sealing lip (→ **fig. 3**). This avoids grease build-up, which can retain heat and limit heat dissipation. For grease lubricated applications, SKF recommends calculating the permissible circumferential speed for oil and halving the result.

Fig. 3

CRW1 seal

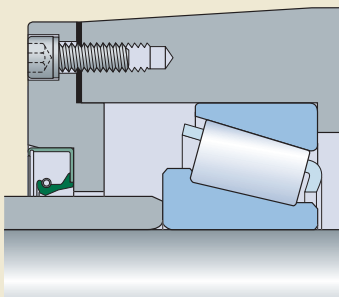

Fig. 4

HMS5 seal

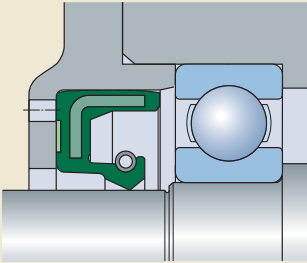

Fig. 5

CRW1 seal

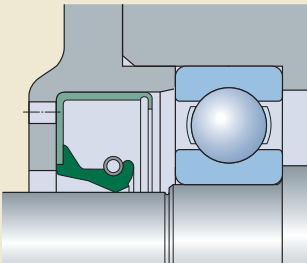

Fig. 6

HDDF metal face seal

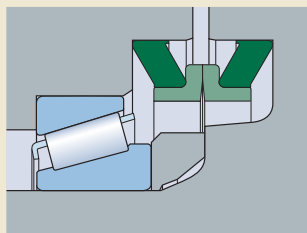
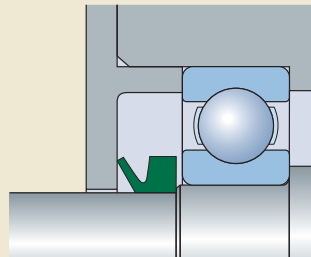

Fig. 7

V-ring



Oil retention

Lubricating oils, particularly relatively low-viscosity oils, are much more difficult to retain than greases. Therefore, HMS5 or CRW1 spring-loaded radial shaft seals (→ **figs. 4 and 5**) are recommended in order to achieve the necessary radial load and resistance to dynamic runout and shaft-to-bore misalignment for a satisfactory sealing performance.

Standard HMS5 seals have a straight lip while CRW1 seals are designed with SKF WAVE lips to provide improved pumping ability, regardless of the direction of shaft rotation (→ **fig. 6** on **page 57**). Another way of increasing a seal's pumping ability is to add a helix pattern, i.e. hydrodynamic features, to the sealing lip design.

The rubber outside diameter, like the one found on HMS5 seals, helps compensate for small imperfections in the housing bore surface and is therefore recommended when the required housing bore surface is questionable.

For very tough operating conditions, where circumferential speeds are relatively low, metal face seals, like the HDDF seal (→ **fig. 6**), can be used for both oil or grease retention.

V-rings (→ **fig. 7**) may also be used to retain oil, provided they are installed on the oil side and supported axially on the shaft.

Fig. 8

CRW1 seal

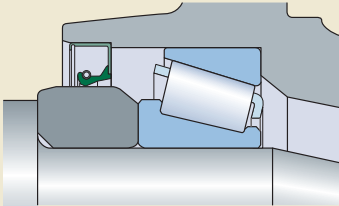

Contaminant exclusion

Radial shaft seals that are primarily used for contaminant exclusion should be installed with the lip pointing outward. When additional protection is needed, SKF recommends a seal design that incorporates an auxiliary lip, for example the HMSA10 or CRWA1 seals.

For tough operating conditions, SKF WAVE seals (→ fig. 8) with hydrodynamic features are recommended. To further enhance sealing efficiency, two single-lip seals can be arranged in tandem (→ fig. 9) or a double-lip seal, like the HDSE1 seal, can be used (→ fig. 10).

V-rings (→ fig. 11) are used primarily to exclude contaminants. These seals, which act as flingers, rotate with the shaft and seal against a surface that is perpendicular to the shaft.

V-rings and axial clamp seals are often used as secondary seals to protect the primary seals from coarse contaminants.

None of these seal arrangements are intended for oil retention.

Fig. 9

CRW1 seals in tandem

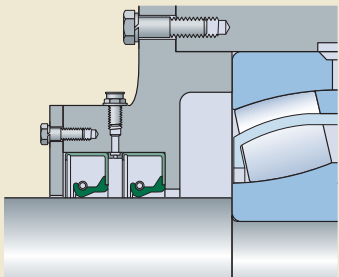

Fig. 10

HDSE1 seal

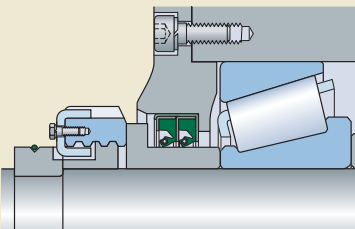

Fig. 11

V-ring

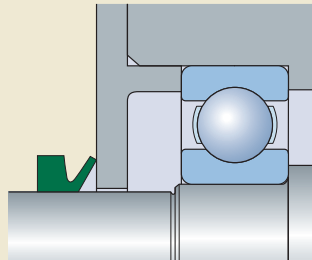
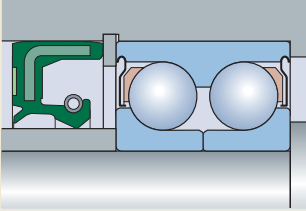

Fig. 12

HMSA10 seal



Retention and exclusion

In many applications, the exclusion of contaminants is just as important as lubricant retention. Seals with an auxiliary lip, like the HMSA10 seals (→ fig. 12), are appropriate for these applications.

Another option is to use two seals installed in opposite directions (→ figs. 13 and 14) or two opposing V-rings (→ fig. 15) with a spacing washer.

Under extremely tough operating conditions, SKF recommends using HDDDF metal face seals (→ fig. 6 on page 18), provided that the sliding velocity of the mating surfaces lies within the permissible range.

Fig. 13

Two seals in opposite direction

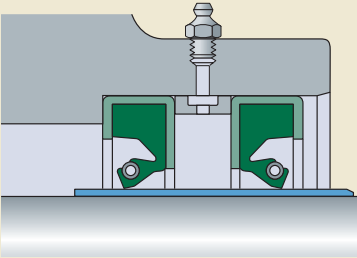

Fig. 14

Two seals in opposite direction

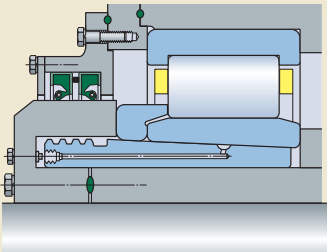

Fig. 15

V-ring

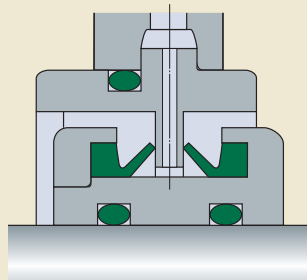
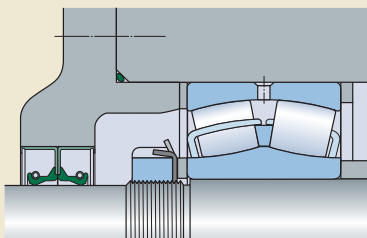

Fig. 16

CRW1 seals



Separating two liquids

When an application has to keep two liquids from coming into contact with each other, there are two suitable solutions. These solutions, which depend on the availability of space and required efficiency, include:

- the use of two separate seals (→ **figs. 16 and 17**), positioned with their lips facing in opposite directions
- the use of HSD1 double-lip seals (→ **fig. 18**)

In both alternatives, the sealing lips must be spring-loaded. When using an HSD1 seal, it is very important to provide a means to lubricate the sealing lips, i.e. the cavity between the sealing lips must be filled with grease prior to installation or during operation via lubrication holes drilled through the metal case into the cavity.

Fig. 17

HMS5 seals

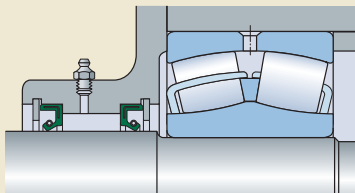
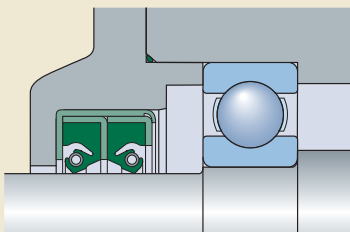

Fig. 18

HSD1 seal



Circumferential and rotational speed

The permissible speed of a seal is determined by its design and sealing lip material as well as the material and condition of the shaft. All of these factors influence the heat generation at the seal counterface. Lubrication of the sealing lip and the characteristics of the lubricant also have a direct influence on heat generation because they have a direct impact on heat dissipation.

Diagram 1 compares the permissible circumferential speeds for various seal designs assuming normal seal operation, grease or oil retention and no pressure differential across the seal.

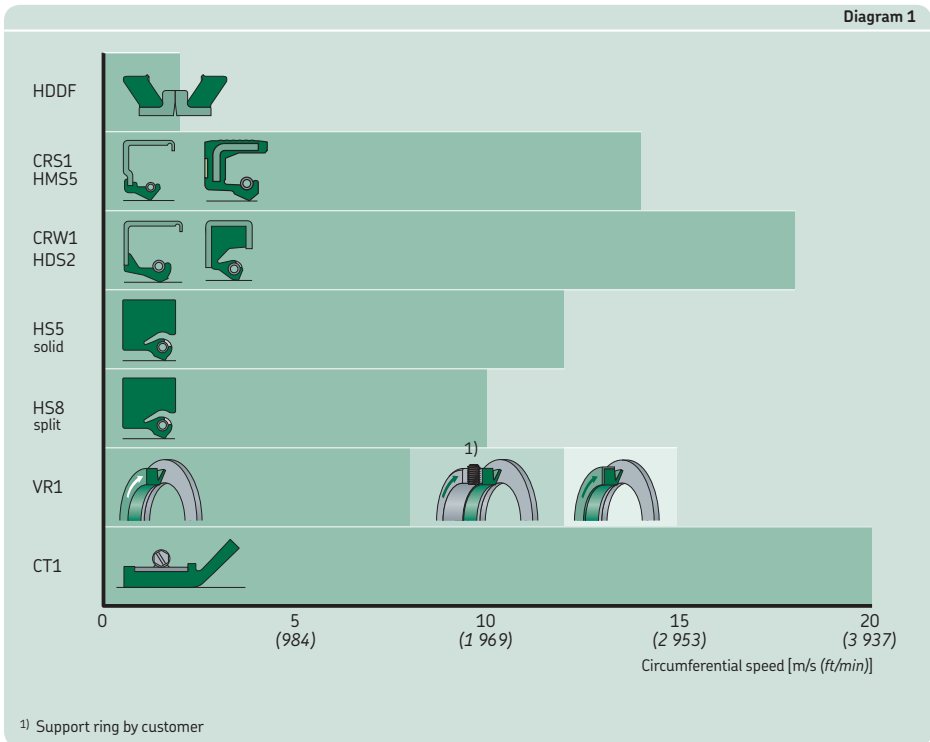
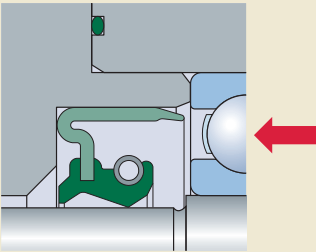

Fig. 19

CRWA5 seal



Pressure differentials

When subjected to a pressure differential, the seal must resist the additional radial load generated by the pressure. If the seal is not designed to resist the pressure, it will be forced against the shaft, increasing the radial load, underlip temperature, friction and wear of the seal and the counterface, resulting in shortened service life.

Standard seals are rated for no more than 0,07 MPa at 5 m/s (10 psi at 1 000 ft/min), but SKF offers CRW5 and CRWA5 pressure profile seals that can accommodate 0,34 MPa at 5 m/s (50 psi at 1 000 ft/min). Beyond 0,34 MPa (50 psi), SKF offers a line of special order PTFE seals that can accommodate more than 3,5 MPa (500 psi).

In applications with pressure differentials, shaft seals should be secured axially from the low-pressure side to prevent them from moving axially. This can be accomplished by installing the seal into a counterbore (→ fig. 19) or by using a retaining ring.

Fig. 20

Special seal design

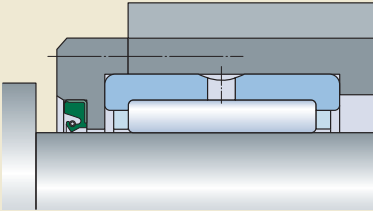

Limited space

In many cases, the available space is insufficient for a radial shaft seal having dimensions in accordance with ISO 6194-1 or DIN 3670. In these situations, special radial shaft seal designs must be used (→ fig. 20).

V-rings (→ fig. 21) are also suitable for applications with limited space because they can be positioned outside the actual seal position. V-rings seal axially by exerting light pressure against the counterface that can be a stationary or rotating machine component.

In applications with large shaft diameters, HS8 seals are an appropriate choice when space is limited (→ fig. 22).

Fig. 21

V-ring seal

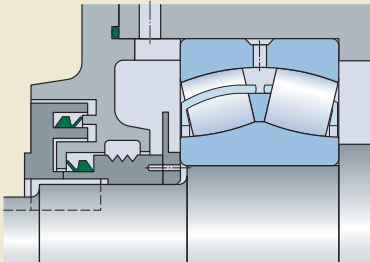

Fig. 22

HS8 seal

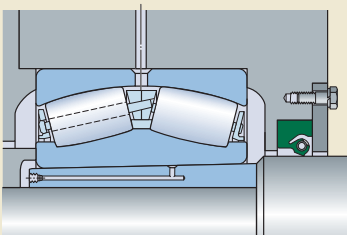
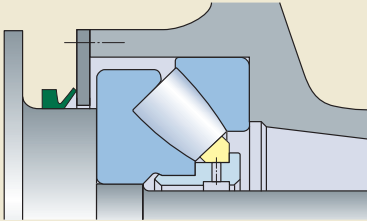

Fig. 23

V-ring seal



Installation restrictions

In applications where the seal cannot be installed via the shaft end, a V-ring or any of the split HSF or HS designs can be used (→ **pages 212 to 214**).

After being positioned on the shaft, HS and HSF seals are held together by a spring and spring connector. These seals should be retained axially in the housing bore by a one-piece or split cover plate.

Split HS radial shaft seals are suitable for circumferential speeds up to 7,5 or 10 m/s (1 480 or 1 970 ft/min), depending on their design, and are available for shaft diameters up to approximately 4 570 mm (180 in.).

Since V-rings are elastic, they can be stretched and are therefore easy to install, even in applications where they have to be passed over other components (→ **fig. 23**). However, in the event that replacing a V-ring would require the time consuming removal of several components, it is advantageous to install one or two replacement V-rings on the shaft from the outset (→ **fig. 24**). When the time comes to replace a worn V-ring, it can be cut and removed and the replacement V-ring can be pushed into position.

Fig. 24

V-ring seals

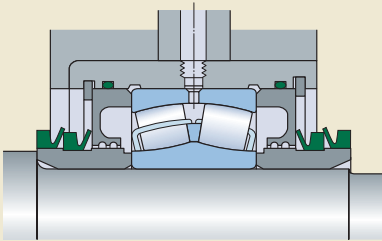
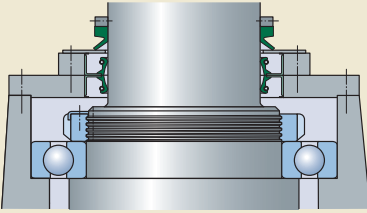

Fig. 25

V-ring seal



Arrangement

Seals installed on vertical shafts are usually more exposed to contaminants like rain water than seals on horizontal shafts. Oil retention is also more challenging for seals installed on vertical shafts. In general, however, all seals listed in the product tables are suitable for use on both horizontal and vertical shafts.

V-rings (→ **figs. 25** and **26**) have an interference fit on the shaft and rotate with it. They act as flingers and are therefore particularly suitable as both primary and secondary seals on vertical shafts. Highly efficient sealing arrangements, like those found in submersible pumps, can be achieved using radial shaft seals in tandem with a V-ring for additional protection against contaminants (→ **fig. 27**).

At relatively low speeds, HDDF metal face seals (→ **fig. 28**) effectively retain grease or oil and prevent the ingress of contaminants on vertical shafts.

Fig. 26

V-ring seal

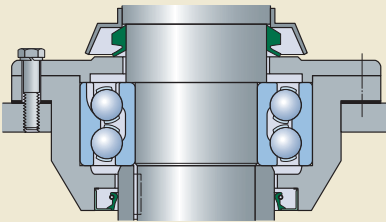

Fig. 27

CRW5 seals + V-ring seal

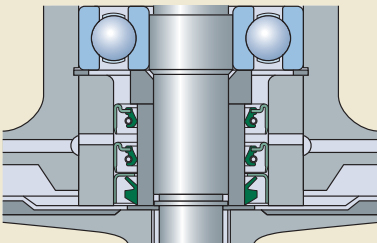
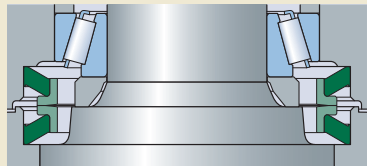

Fig. 28

HDDF metal face seal



Counterface design

The service life and performance of a seal are largely influenced by:

- shaft material and hardness
- shaft surface finish and tolerance grade
- dynamic runout and shaft-to-bore misalignment

A shaft surface that is too smooth can lead to lubricant starvation, while a shaft surface that is too rough can accelerate sealing lip wear. The shaft surface should be machined without directionality as directionality can cause leakage depending on the direction of rotation. Dynamic runout and shaft-to-bore misalignment cause an uneven radial load on the circumference of the sealing lip. As a result, the sealing lip, particularly at high speeds, will not be able to follow the shaft. This, in turn, will result in a gap between the sealing lip and the shaft, causing reduced sealing ability.

Unlike radial shaft seals, V-rings and axial clamp seals are not affected by normal coaxiality deviations or runout.

Axial movement

Axial movement of the shaft relative to the housing bore does not detract from the sealing ability of radial shaft seals (→ **fig. 29**), provided that the total surface in contact with the lip has the same quality with respect to hardness and surface finish.

The amount of axial movement that can be accommodated by V-rings, axial clamp seals and HDDF seals is limited by the permissible displacement of the seal relative to its counterface.

Fig. 29

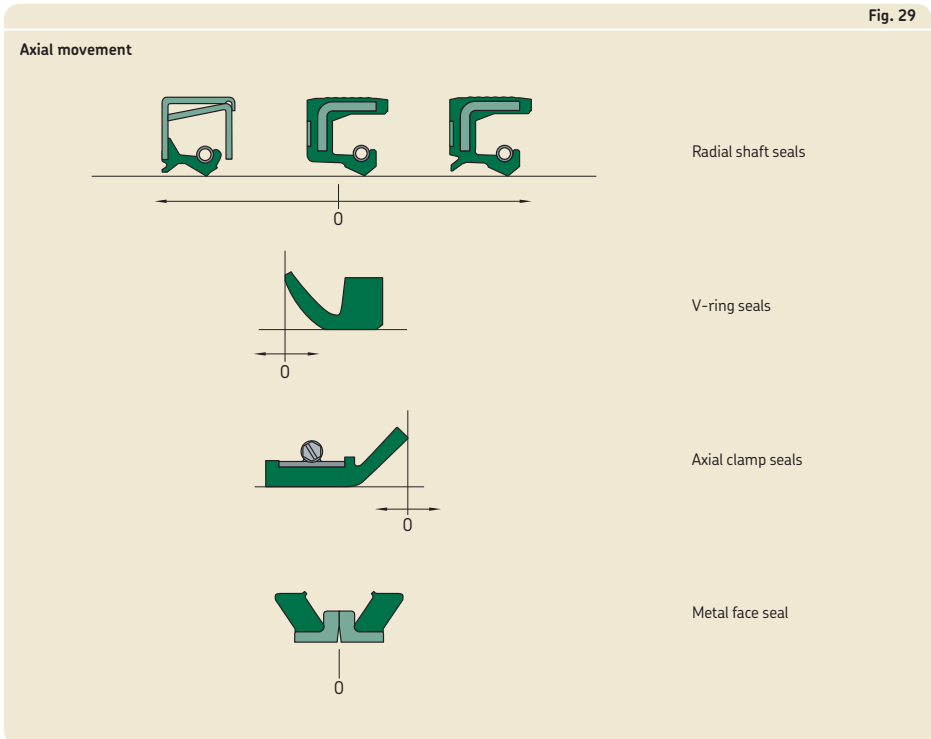

Seal materials

Cases and inserts

Metal cases and reinforcements for SKF radial shaft seals are manufactured standard from deep-drawn carbon sheet steel. The exposed surfaces are treated to protect them from corrosion during normal handling and storage.

SKF radial shaft seals that will be used in corrosive environments can also be designed with a stainless steel case on request.

Garter springs

The garter springs on SKF radial shaft seals are manufactured standard from cold-drawn steel wire. Exceptions are the metal-cased HDS seals and the all-rubber HS seals that are designed with stainless steel garter springs.

SKF Bore Tite Coating

SKF Bore Tite Coating is a water-based acrylic sealant available on most SKF metal-cased seals. The sealant is used as a coating on the outside diameter of the seal. SKF Bore Tite Coating is pliable with a thickness of 0,03 to 0,07 mm (*0.0012 to 0.0028 in.*) to compensate for small imperfections in the housing bore surface. The general guideline in Rubber Manufacturers Association (RMA) is, that if the bore surface texture is greater than $2,5 \mu\text{m}$ (*100 \mu\text{in.}*) R_a , a sealant should be used. This sealant can be used at temperatures up to $200 \text{ }^\circ\text{C}$ (*390 }^\circ\text{F}*) and is compatible with most oils, greases, aqueous acids and alkalis, alcohols and glycols. Please note that SKF Bore Tite Coating is not compatible with aromatics, ketones or esters. Contact with these substances will, however, have little or no effect if wiped off quickly.

Adhesives and bonding agents

Adhesives and bonding agents are used to achieve static sealing ability and satisfactory bonding between metal and elastomers in seal designs. Both of them can be solvent or water based depending on the metal and elastomer to be bonded.

Sealing lip materials

In addition to its design, the material of a sealing lip can have a significant impact on sealing performance and reliability. SKF, therefore, manufactures seals using a variety of sealing lip materials to meet the needs of different applications.

The sealing lips of SKF seals are generally made of elastomer materials. However, thermoplastics like polytetrafluoroethylene (PTFE) are gaining in importance. PTFE is mainly used for special seals intended for particular applications where improved thermal or chemical resistance is demanded.

SKF industrial shaft seals are generally manufactured from the materials listed in **table 1**. These materials have characteristics that make them particularly suitable for specific applications.

By changing the actual formulation and blending, it is possible to modify the characteristics of the elastomers relative to:

- resistance to swelling
- elasticity
- chemical resistance
- thermal resistance
- behaviour in the cold
- gas permeability

Details about the chemical resistance of sealing lip materials to various media encountered in operation are provided in the section *Chemical resistance*, **page 35**.

A code is used to identify the sealing lip material of SKF seals (→ **table 1**). The code also appears in the designations of metric radial shaft seals. For seals manufactured from a combination of materials, a combination of code letters is used, like RD (nitrile rubber and SKF Duralip).

Table 1

SKF sealing lip materials			
Composition of basic material	Designation according to SKF	Designation according to	
		ISO 1629 ISO 1043-1 DIN 7728 Part 1	ASTM ¹⁾ D1418 ASTM D1600
Acrylonitrile-butadiene rubber (nitrile rubber)	R, RG	NBR	NBR
Hydrogenated acrylonitrile-butadiene rubber (SKF Duratemp)	H	HNBR	HNBR
Carboxylated nitrile rubber (SKF Duralip)	D	XNBR	XNBR
Polyacrylate elastomer	P	ACM	ACM
Silicone rubber	S	MVQ	VMQ
Fluoro rubber (SKF Duralife ²⁾)	V	FPM	FKM
Polytetrafluoroethylene	T	PTFE	PTFE

¹⁾ American Society for Testing and Materials
²⁾ Previously named *LongLife*

Nitrile rubber (R)

The term nitrile rubber is used in this publication for acrylonitrile-butadiene rubber (NBR). This material has very good engineering properties and is a general-purpose sealing lip material. It is a copolymer manufactured from acrylonitrile and butadiene that provides good resistance to the following media:

- Most mineral oils and greases with a mineral oil base
- Normal fuels like gasoline, diesel and light heating oils
- Animal and vegetable oils and fats and hot water

Nitrile rubber also tolerates short-term dry running of the sealing lip. The permissible operating temperature range of nitrile rubber is -40 to $+100$ °C (-40 to $+210$ °F). For brief periods, temperatures of up to 120 °C (250 °F) can be tolerated.

SKF also offers a special nitrile rubber compound with a temperature range between -55 and $+110$ °C (-65 and $+230$ °F).

SKF Duralip (D)

SKF Duralip is a carboxylated nitrile rubber (XNBR) developed by SKF that combines the good technical properties of nitrile rubber with an increased resistance to wear (→ **diagram 2** on **page 33**). It is mainly used for seals for heavy industrial applications. Seals made of this material should be chosen when abrasive contaminants like sand, soil and scale could reach the seal counterface on the shaft.

SKF Duratemp (H)

SKF Duratemp is a hydrogenated nitrile rubber (HNBR) developed by SKF that combines the wear resistance of SKF Duralip with increased high-temperature resistance (→ **diagram 3** on **page 34**). SKF Duratemp is also more resistant to chemical attack, weather, ageing and ozone. However, mixtures of oil in air may have a negative effect. The upper operating temperature limit is 150 °C (300 °F), which is significantly higher than that of ordinary nitrile rubber. SKF Duratemp is mainly used for seals for heavy industrial applications or where extended service life is required.

SKF Duralife¹⁾ (V)

The fluoro rubber (FKM) compound, SKF Duralife, has been developed by SKF and is characterized by its very good wear, thermal and chemical resistance. Its resistance to weather and ageing from UV light and ozone is also very good and its gas permeability is very slight.

SKF Duralife has exceptional properties even under harsh environmental conditions and can withstand operating temperatures up to 200 °C (390 °F). The material is also resistant to oils and hydraulic fluids, fuels and lubricants, mineral acids and aliphatics as well as aromatic hydrocarbons that would cause many other seal materials to fail. Seals made of SKF Duralife can also tolerate dry running of the lip for short periods. The seals should not be used in the presence of esters, ethers, ketones, certain amines and hot anhydrous hydrofluorides. Because of the compound's valuable properties, SKF manufactures seals with sealing lips made of SKF Duralife for all common shaft diameters.

Polytetrafluoroethylene (PTFE)

PTFE is a thermoplastic polymer that is compatible with a wide assortment of lubricants and features chemical resistance that is far superior to that of any other sealing lip material. PTFE has a smooth, dirt-resistant surface. Seals with PTFE lips can accommodate high surface speeds while offering extended service life. The seals can tolerate dry running and are particularly valuable in highly contaminated applications because of their excellent exclusion ability. PTFE is used for auxiliary seal elements or for primary sealing lips for special applications. For optimum performance, PTFE seal elements require a high-quality seal counterface and extra care during installation. The normal operating temperature range extends from -70 to +200 °C (-90 to +390 °F), but may go up to 250 °C (480 °F).

WARNING:

At temperatures above 300 °C (570 °F), all fluoro elastomers and PTFE compounds give off dangerous fumes. This can occur, for example, if a welding torch is used when removing a bearing. Although the fumes are only produced at such high temperatures, once heated, the seals will be dangerous to handle even when they have cooled down. If it is necessary to handle PTFE or fluoro elastomer seals that have been subjected to the high temperatures mentioned above, the following safety precautions should be observed:

- Protective goggles and gloves should always be worn.
- The remains of seals should be put in an airtight plastic container marked "Material will etch".
- Comply with the safety precautions included in the material safety data that can be provided upon request.

If there is contact with your skin, this should be washed with soap and plenty of water. Wash your eyes with plenty of water if these materials get into your eyes. A doctor should always be consulted. This also applies if the fumes have been inhaled.

¹⁾ Previously named *LongLife*

Polyacrylate elastomer

Polyacrylate elastomers are more heat resistant than nitrile rubber or SKF Duralip. The operating temperature range for polyacrylate elastomers lies between -40 and $+150$ °C (-40 and $+300$ °F) and in some fluids the upper limit may be extended to 175 °C (345 °F). Seals of polyacrylate are resistant to ageing and ozone and are also suitable for use with lubricants containing EP additives. They should not be used to seal water, acids or alkalis etc. Dry running should be avoided.

Silicone rubber

Silicone rubber is characterized by high thermal resistance and can withstand temperatures ranging from -70 to $+160$ °C (-90 to $+320$ °F). Silicone rubber absorbs lubricants, thereby minimizing friction and wear. SKF silicone rubber seals are particularly suitable for applications with very low or very high temperatures and for low-friction sealing of bearing arrangements. They are not very resistant to oxidized oils or certain EP additives and should be protected against abrasive substances. Sealing lips made of silicone rubber should not be exposed to dry running.

Wear resistance

The wear resistance of a seal depends largely on the sealing lip material, as well as on the shaft surface finish, type of lubricant, circumferential speed, temperature and pressure differentials.

A comparison of wear resistance for various sealing lip materials used by SKF is provided in **diagram 2**. It is valid for seals of the same size, operating under identical conditions.

Diagram 2

Wear resistance

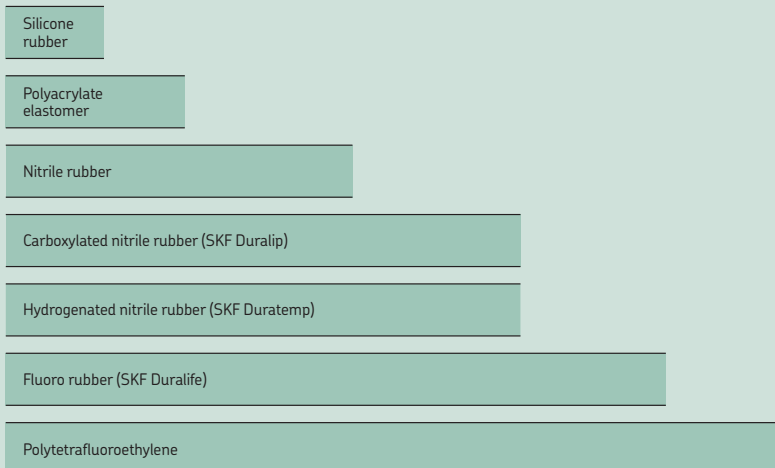

Operating temperatures

Both low and high temperatures influence the sealing performance. At low temperatures, the sealing lip loses its elasticity and becomes hard and brittle. Sealing efficiency decreases and the seal becomes more susceptible to mechanical damage.

For applications where temperatures are continuously high, special high-temperature lip materials should be used, for example, PTFE or the SKF fluoro rubber material, SKF Duralife.

Friction, circumferential speed, viscosity of the medium being sealed as well as the specific heat transfer along the shaft influence the temperature at the sealing position and the temperature between the lip and lubricant film on the counterface. High temperatures generally lead to a breakdown of the lubricant film, resulting in insufficient lubrication, one of the most common causes of premature seal failure.

The static sealing ability between the outside diameter of the seal and the housing bore may

also be affected if these components are made of different materials with significantly different coefficients of expansion and shrinkage.

Refer to **diagram 3** to view the permissible operating temperature ranges of sealing lip materials normally used by SKF.

Diagram 3

Permissible operating temperatures

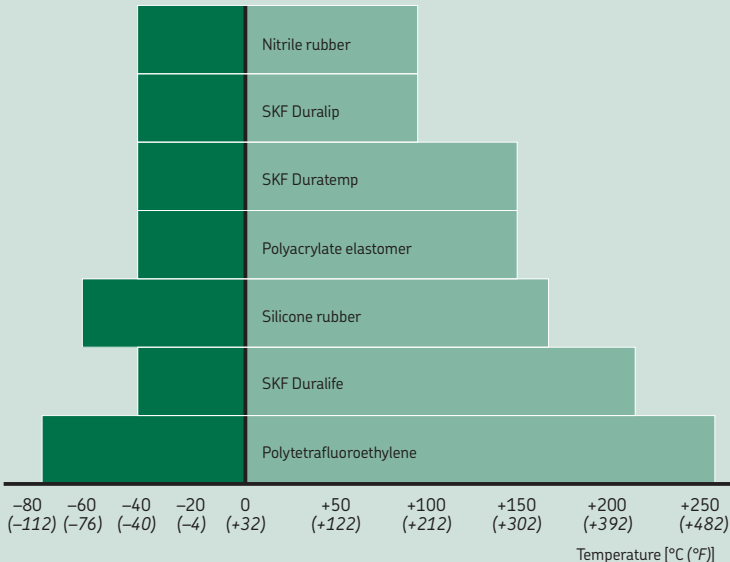

Chemical resistance

In **table 2, *Chemical resistance*** (→ **pages 36 to 43**), information is provided regarding the resistance of SKF sealing lip materials to most of the substances encountered in industrial applications. The information is based on in-house testing and the experience of users, as well as information from the suppliers of the various materials. Unless otherwise stated, the information is valid for media of commercial purity and quality.

The chemical resistance of a seal is influenced by temperature, pressure and the amount of media present. Other important factors to consider when selecting a suitable sealing lip material include:

- type of service (static or dynamic)
- circumferential speed of the sealing lip
- shaft and housing materials
- surface finish of the seal counterface

Because the above mentioned factors also influence the service life and performance of the seal, the information contained in the table *Chemical resistance* can only be considered as a rough guide.

Explanation for table 2 (→ pages 36 to 43), *Chemical resistance*

RT = room temperature (20 °C (70 °F))

1 = minor effect

2 = moderate effect

3 = static only

4 = not recommended

5 = insufficient data, test before use

Table 2

Chemical resistance

Medium	Temperature	Medium's effect on sealing lip material			
		R, D, H	V	P	S
–	°C (°F)	–			
A					
Acetaldehyde	RT	4	4	4	2
Acetamide	RT	1	2	4	2
Acetic acid, 100% (glacial)	60 (140)	3	3	4	2
Acetic acid, 30%	RT	2	2	4	1
Acetic acid, 3% (vinegar)	RT	2	1	4	1
Acetic anhydride	RT / 80 (175)	3	4	4	3
Acetone	RT	4	4	4	3
Acetophenone	RT	4	4	4	4
Acetylene	60 (140)	1	1	5	2
Acrylonitrile	RT / 60 (140)	4	3	4	4
Adipic acid (aq)	RT	1	1	5	5
Alum (aq)	100 (210)	1	1	4	1
Aluminium acetate (aq)	RT	2	4	4	4
Aluminium chloride (aq)	RT	1	1	1	2
Aluminium fluoride (aq)	RT	1	1	5	2
Aluminium nitrate (aq)	RT	1	1	5	2
Aluminium phosphate (aq)	RT	1	1	5	1
Aluminium sulphate (aq)	RT / 60 (140)	1	1	4	1
Ammonia (anhydrous)	RT	2	4	4	3
Ammonia gas	RT	1	4	4	2
Ammonia gas	80 (175) / 100 (210)	4	4	4	1
Ammonium carbonate (aq)	RT / 60 (140)	2	5	4	5
Ammonium chloride (aq)	RT / 60 (140)	1	1	5	5
Ammonium chloride (dry) (sal ammoniac)	RT	1	1	1	2
Ammonium nitrate (aq)	RT	1	5	2	5
Ammonium persulphate (aq)	RT	4	5	4	5
Ammonium phosphate (aq)	RT / 60 (140)	1	5	5	1
Ammonium sulphate (aq)	100 (210)	1	4	4	5
Amyl acetate	RT	4	4	4	4
Amyl alcohol	60 (140)	2	2	4	4
Aniline	60 (140) / 100 (210)	4	3	4	4
Aniline dyes	RT	4	2	4	3
Aniline hydrochloride	RT	2	2	4	4
Aniline hydrochloride	100 (210)	4	5	5	5
Animal fats	80 (175)	1	1	1	2
Aqua Regia	RT	4	5	4	4
Arsenic acid	RT / 60 (140)	1	1	3	1
Arsenic trichloride (aq)	RT	1	5	5	5
Asphalt (liquid)	100 (210)	2	2	4	4
B					
Barium chloride (aq)	RT / 60 (140)	1	1	1	1
Barium hydroxide (aq)	RT / 60 (140)	1	1	4	1
Barium sulphate	RT / 60 (140)	1	1	4	1
Barium sulphide (aq)	RT / 60 (140)	1	1	4	1
Beer	RT	1	1	4	1
Benzaldehyde	RT / 60 (140)	4	4	4	4
Benzene	RT	4	1	4	4
Benzene sulphononic acid	RT	4	1	4	4
Benzoic acid	RT / 60 (140)	4	1	4	4
Benzoyl chloride	RT	4	1	4	5
Benzyl alcohol	RT / 60 (140)	4	1	1	2
Benzyl benzoate	50 (120) / 60 (140)	4	1	4	5
Benzyl chloride	RT	4	1	4	4
Blast furnace gas	100 (210)	4	1	4	1
Borax (aq)	RT / 60 (140)	2	1	5	2
Bordeaux mixture	RT	2	1	4	2
Boric acid	60 (140) / 100 (210)	1	1	4	1
Brake fluid, ATE	80 (175)	4	4	4	1
Brake fluid, glycol ether	80 (175)	4	5	4	1
Brine (sodium chloride, aq)	RT / 50 (120)	1	1	4	1
Bromine, anhydrous (liquid/gaseous)	RT	4	1	4	4
Bromine trifluoride	RT	4	4	4	4
Bromine water	RT	4	1	4	4
Bromobenzene	RT	4	1	4	4

Chemical resistance

Medium	Temperature	Medium's effect on sealing lip material			
		R, D, H	V	P	S
–	°C (°F)	–			
Bunker oil	60 (140)	1	1	1	2
Butadiene (gaseous or liquified)	RT	4	1	4	4
Butane (gaseous or liquified)	RT	1	1	1	4
Butter (animal fat)	RT / 80 (175)	1	1	1	2
Butyl acetate	RT	4	4	4	4
Butyl acrylate	RT	4	4	4	5
Butyl alcohol	RT	2	1	4	2
Butyl amines	RT	3	4	4	4
Butylene	RT	2	1	4	4
Butyl stearate	50 (120)	2	1	5	5
Butyraldehyde	RT	4	4	4	4
C					
Calcium acetate (aq)	RT	2	4	4	4
Calcium bisulphite (aq)	RT	1	1	4	1
Calcium chloride (aq)	60 (140)	1	1	1	1
Calcium hydroxide (aq)	RT	1	1	4	1
Calcium hypochlorite (aq)	RT / 60 (140)	2	1	4	2
Calcium nitrate (aq)	RT / 40 (105)	1	1	1	2
Cane sugar liquors	RT / 60 (140)	1	1	4	1
Carbon dioxide	RT	1	1	5	2
Carbon disulphide	RT	3	1	3	4
Carbonic acid	RT	2	1	1	1
Carbon monoxide	60 (140)	1	1	5	1
Carbon tetrachloride	RT / 60 (140)	3	1	4	4
Castor oil	RT	1	1	1	1
Cellosolve (ethyl glycol)	RT	4	3	4	4
Cellosolve acetate (ethyl glycol acetate)	RT	4	4	4	4
Chlorine (dry)	RT	4	1	4	4
Chlorine (wet)	RT	4	1	4	4
Chlorine dioxide	RT	4	1	4	5
Chlorine trifluoride	RT	4	4	4	4
Chloroacetic acid	60 (140)	4	4	4	5
Chloroacetone	RT	4	4	4	4
Chlorobenzene	RT	4	1	4	4
Chlorobromomethane	RT	4	1	4	4
Chlorobutadiene	RT	4	1	4	4
Chloroform	RT	4	1	4	4
Chlorosulphonic acid	RT	4	4	4	4
Chlorotoluene	RT	4	1	4	4
Chromic acid	60 (140)	4	1	4	3
Citric acid	60 (140) / 70 (160)	1	1	5	1
Cobalt chloride (aq)	RT	1	1	4	2
Coconut oil	50 (120) / 80 (175)	1	1	1	1
Cod liver oil	RT	1	1	1	2
Coke oven gas	80 (175)	4	1	4	2
Copper acetate (aq)	RT	2	4	4	4
Copper chloride (aq)	RT	1	1	1	1
Copper sulphate (aq)	60 (140)	1	1	4	1
Corn oil	RT / 60 (140)	1	1	1	1
Cottonseed oil	RT / 70 (160)	1	1	1	1
Cresol	50 (120) / 70 (160)	4	1	4	4
Cumene (isopropylbenzene)	RT	4	1	4	4
Cyclohexane	RT	1	1	1	4
Cyclohexanol	RT	3	1	5	4
Cyclohexanone	RT	4	4	4	4
p-Cymene	RT	4	1	4	4
D					
Decahydronaphthalene (decalin)	RT / 60 (140)	4	1	5	4
Detergent	RT	1	1	4	1
Developing fluids (photography)	RT	1	1	5	1
Diacetone alcohol	RT	4	4	4	2
Dibenzyl ether	RT	4	4	5	5
Dibutyl amine	RT	4	4	4	3
Dibutyl ether	RT	4	3	3	4

Chemical resistance

Medium	Temperature	Medium's effect on sealing lip material			
		R, D, H	V	P	S
–	°C (°F)	–			
Dibutyl phthalate	RT / 60 (140)	4	3	4	2
Dibutyl sebacate	RT / 60 (140)	4	2	4	2
o-Dichlorobenzene	RT	4	1	4	4
Dicyclohexylamine	RT	3	4	4	5
Diethyl amine	RT	2	4	4	2
Diethyl benzene	RT	4	1	5	4
Diethyl ether	RT	4	4	3	4
Diethyl sebacate	RT	2	2	4	2
Diisopropyl benzene	RT	4	1	5	5
Dimethyl aniline (Xylidine)	RT	3	4	4	4
Dimethyl ether	RT	1	2	4	1
Dimethyl formamide	RT / 60 (140)	2	4	4	2
Dimethyl phthalate	RT	4	2	4	5
Dioctyl phthalate	RT / 60 (140)	3	2	4	3
Dioctyl sebacate	RT / 60 (140)	4	2	4	3
Dioxane	RT / 60 (140)	4	4	4	4
Dioxolane	RT	4	4	4	4
Dipentene	RT	2	1	4	4
Diphenyl oxide	RT	4	1	4	3
Dowtherm oils	100 (210)	4	1	4	3
Dry cleaning fluids	40 (105)	3	1	4	4
E					
Epichlorohydrin	RT	4	4	4	4
Ethane	RT	1	1	1	4
Ethanol (denatured alcohol)	RT	1	1	4	1
Ethanolamine (monoethanolamine)	RT	2	4	4	2
Ethanolamine (di- and triethanolamine)	50 (120)	5	4	4	2
Ethyl acetate	RT	4	4	4	2
Ethyl acrylate	RT	4	4	4	2
Ethyl benzene	RT	4	1	4	4
Ethyl benzoate	RT	4	1	4	4
Ethyl chloride	RT	1	1	4	4
Ethylene	RT	1	1	5	5
Ethylene chloride	RT	4	2	4	4
Ethylene chlorohydrin	RT	4	1	4	3
Ethylene diamine	RT	1	4	4	1
Ethylene glycol	RT	1	1	2	1/2
Ethylene glycol	100 (210)	1	1	3	1/2
Ethylene oxide	RT	4	4	4	4
Ethylene trichloride	RT	4	1	4	4
Ethyl ether	RT	3	4	4	4
Ethyl formate	RT	4	1	5	5
Ethyl glycol (Cellosolve)	RT	4	3	4	4
Ethyl glycol acetate (Cellosolve acetate)	RT	4	4	4	4
Ethyl silicate	RT	1	1	5	5
F					
Fatty acids	100 (210)	2	1	5	3
Ferric chloride (aq)	RT	1	1	1	2
Ferric nitrate (aq)	RT	1	1	1	3
Ferric sulphate (aq)	RT	1	1	1	2
Fish oil	RT	1	1	5	1
Fluorine (liquified)	RT	4	2	4	4
Fluorobenzene	RT	4	1	4	4
Fluorosilic acid	60 (140)	1	1	5	4
Formaldehyde	RT	3	1	4	2
Formaldehyde, 37%	below 100 (210)	2	1	4	2
Formic acid	RT / 60 (140)	2	3	5	2
Fuels					
– Aero engine fuels JP:					
– JP3 (MIL-J-5624 G)	RT	1	1	2	4
– JP4 (MIL-J-5624 G)	RT	1	1	2	4
– JP5 (MIL-J-5624 G)	RT	1	1	2	4
– JP6 (MIL-F-25656 B)	RT / 60 (140)	1	1	5	4

Chemical resistance

Medium	Temperature	Medium's effect on sealing lip material			
		R, D, H	V	P	S
–	°C (°F)	–			
–ASTM reference fuels:					
–ASTM-A (MIL-S-3136 B Typ 1)	RT / 60 (140)	1	1	2	4
–ASTM-B (MIL-S-3136 B Typ 111)	RT / 60 (140)	1	1	5	4
–ASTM-C	RT / 60 (140)	2	1	4	4
– Diesel fuel	60 (140)	1	1	2	2
– Fuel oil	60 (140)	1	1	1	4
– Gasohol (10% ethanol or methanol)	RT	2	3	4	4
– Kerosene	RT	1	1	1	4
– Mineral oil	100 (210)	1	1	1	2
– Petrol	RT	1	1	4	4
Fumaric acid	RT	1	1	4	2
Furan	RT	4	5	4	5
Furfural	RT	4	4	4	4
Furfuran	RT	4	5	4	5
G					
Gelatine (aq)	40 (105)	1	1	4	1
Glucose	RT	1	1	5	1
Glue	RT	1	1	5	1
Glycerin	100 (210)	1	1	3	1
Glycols	100 (210)	1	1	4	1/2
H					
n-Hexaldehyde	RT	4	4	5	2
Hexane	RT / 60 (140)	1	1	1	4
1-Hexene	RT	2	1	1	4
Hexyl alcohol	RT	1	1	4	2
Hydraulic fluids					
– Hydraulic oils (acc. to DIN 51524)	80 (175)	1	1	1	3
– Hydraulic fluids (acc to DIN 51502):					
– HFA (oil in water emulsion)	55 (130)	1	1	5	5
– HFB (water in oil emulsion)	60 (140)	1	1	5	5
– HFC (aqueous Polymer solutions)	60 (140)	1	1	5	1
– HFD (phosphoric esters)	80 (175)	4	2/4	4	4
– Skydrol 500	80 (175)	4	4	4	3
– Skydrol 7000	80 (175)	4	2	4	3
Hydrazine	RT	2	4	5	3
Hydrobromic acid	RT / 60 (140)	4	1	4	4
Hydrochloric acid (conc.)	RT	3	1	4	3
Hydrochloric acid (conc.)	80 (175)	4	2	4	4
Hydrocyanic acid (Prussic acid)	RT	2	1	4	3
Hydrofluoric acid (conc.)	RT	4	1	4	4
Hydrofluoric acid (conc.)	100 (210)	4	3	4	4
Hydrofluoric acid (anhydrous)	100 (210)	4	4	4	4
Hydrogen gas	RT	1	1	2	3
Hydrogen peroxide (90%)	RT	4	2	4	2
Hydrogen sulphide (wet)	RT / 100 (210)	4	4	4	3
Hydroquinone	RT	4	2	4	5
Hypochlorous acid	RT	4	1	4	5
I					
Iodine pentafluoride	RT	4	4	4	4
Isobutyl alcohol	RT	2	1	4	1
Isooctane	RT	1	1	1	4
Isophorone	RT	4	4	4	4
Isopropyl acetate	RT / 80 (175)	4	4	4	4
Isopropyl alcohol	RT / 60 (140)	2	1	4	1
Isopropyl chloride	RT	4	1	4	4
Isopropyl ether	RT / 60 (140)	2	4	3	4
L					
Lactic acid	RT	1	1	4	1
Lactic acid	100 (210)	4	1	4	2
Lard	80 (175)	1	1	1	2
Lavender oil	RT	2	1	2	4
Lead acetate (aq)	RT / 60 (140)	2	2	4	4

Chemical resistance

Medium	Temperature	Medium's effect on sealing lip material			
		R, D, H	V	P	S
–	°C (°F)	–			
Lead nitrate (aq)	RT	1	5	5	2
Linoleic acid	RT	2	2	5	2
Linseed oil	RT / 60 (140)	1	1	1	1
Lubricants					
–ASTM oil No. 1	100 (210)	1	1	1	3
–ASTM oil No. 2	100 (210)	1	1	1	3
–ASTM oil No. 3	100 (210)	1	1	1	3
–ATF oils, type A	100 (210)	1	1	1	4
–ATF oils, type I	100 (210)	1	1	1	4
–ATF oils, type II	100 (210)	1	1	1	4
–ATF oils, type F	100 (210)	1	1	1	4
–ATF oils, type Mercon	100 (210)	1	1	1	4
–EP lubes	100 (210)	2	1	1	4
–Fluorolube	100 (210)	1	2	5	1
– Grease MIL-G-7118 A	80 (175)	1	1	3	3
– Grease MIL-G-7711 A	80 (175)	1	1	1	3
– Lubricating oils (petroleum)	100 (210)	1	1	1	4
– Red oil (MIL-H-5606)	100 (210)	1	1	1	4
– RJ-1 (MIL-F-25558 B)	100 (210)	1	1	1	4
– RP-1 (MIL-F-25576 C)	100 (210)	1	1	1	4
– Motor oil SAE 30	100 (210)	1	1	1	1
– Transmission oil SAE 90	100 (210)	1	1	1	4
– Transmission oil MIL-L-23699 A	100 (210)	1	1	3	3
– Silicone greases	120 (250)	1	1	1	3
– Silicone oils	120 (250)	1	1	1	3
– Transformer oil (Pyranol)	60 (140)	4	1	5	4
– Transformer oil	60 (140)	1	1	2	2
– Transmission fluid type A	RT	1	1	1	2
– Turbine oil	100 (210)	2	1	1	4
M					
Magnesium chloride (aq)	100 (210)	1	1	5	1
Magnesium hydroxide (aq)	100 (210)	2	1	4	5
Magnesium sulphate (aq)	100 (210)	1	1	4	1
Maleic acid	100 (210)	4	1	4	5
Maleic anhydride	60 (140)	4	4	4	5
Malic acid	RT	1	1	4	2
Mercury	RT / 60 (140)	1	1	5	5
Mercury chloride (aq)	RT / 60 (140)	1	1	5	5
Mesityl oxide	RT	4	4	4	4
Methane	RT	1	2	1	4
Methanol (methyl alcohol)	60 (140)	1	4	4	1
Methyl acetate	RT	4	4	4	4
Methyl acrylate	RT	4	4	4	4
Methyl aniline	RT	4	2	4	5
Methyl bromide	RT	2	1	3	5
Methyl cellosolve (methyl glycol)	RT	3	4	4	4
Methyl chloride	RT	4	2	4	4
Methyl cyclopentane	RT	4	2	4	4
Methylene chloride	RT	4	2	4	4
Methyl ethyl ketone	RT	4	4	4	4
Methyl formate	RT	4	5	5	5
Methyl glycol (Cellosolve)	RT	3	4	4	4
Methyl isobutyl ketone	RT	4	4	4	4
Methyl methacrylate	RT	4	4	4	4
Methyl salicylate	RT	4	5	5	5
Milk	RT	1	1	4	1
Mustard gas	RT	5	5	5	1
N					
Naphtha	RT	2	1	2	4
Naphthalene	60 (140)	4	1	5	4
Naphthalenic acid	RT	2	1	5	4
Natural gas	RT	1	1	2	1
Neat-s-foot oil	RT / 60 (140)	1	1	1	2
Nickel acetate (aq)	RT	2	4	4	4

Chemical resistance

Medium	Temperature	Medium's effect on sealing lip material			
		R, D, H	V	P	S
–	°C (°F)	–			
Nickel chloride	RT	1	1	4	1
Nickel sulphate (aq)	RT / 60 (140)	1	1	4	1
Nitric acid (conc.)	RT	4	3	4	4
Nitric acid (fuming)	RT	4	4	4	4
Nitric acid (dilute)	RT	4	1	4	2
Nitrobenzene	50 (120)	4	2	4	4
Nitroethane	RT	4	4	4	4
Nitrogen	20 (55)	1	1	1	1
Nitrogen tetroxide	RT	4	4	4	4
Nitromethane	RT	4	4	4	4
O					
Octadecane	RT / 50 (120)	1	1	2	4
n-Octane	RT	2	1	4	4
Octyl alcohol	RT	2	1	4	2
Oleic acid	70 (160)	1	2	2	4
Olive oil	60 (140)	1	1	1	3
Oxalic acid	70 (160)	2	1	5	4
Oxygen	RT	2	1	2	1
Oxygen	>100 (210)	4	2	4	2
Ozone	RT	4	1	2	1
P					
Palmitic acid	60 (140)	1	1	4	4
Peanut oil	RT / 50 (120)	1	1	1	1
Perchloric acid	RT	4	1	4	4
Perchloroethylene	RT / 60 (140)	2	1	4	4
Petroleum	below 120 (250)	1	1	2	2
Petroleum	above 120 (250)	4	2	4	4
Petroleum ether	RT / 60 (140)	1	1	1	4
Petroleum gas (liquified)	RT	1	1	3	3
Phenol	60 (140) / 100 (210)	4	1	4	4
Phenyl ethyl ether	RT	4	4	4	4
Phenyl hydrazine	RT / 60 (140)	4	1	4	5
Phoron (diisopropylidene acetone)	60 (140)	4	4	4	4
Phosphoric acid, 20%	50 (120) / 60 (140)	2	1	5	2
Phosphoric acid, 45%	50 (120) / 60 (140)	4	1	5	3
Phosphorus trichloride	RT	4	1	5	5
Pickling solution	RT	4	2	4	4
Picric acid	RT	4	1	5	4
Pinene	RT	2	1	4	4
Pine oil	RT	4	1	5	4
Piperidine	RT	4	4	4	4
Potassium acetate (aq)	RT	2	4	4	4
Potassium chloride (aq)	RT / 60 (140)	1	1	1	1
Potassium cyanide (aq)	RT / 50 (120)	1	1	1	1
Potassium dichromate (aq)	RT	1	1	1	1
Potassium hydroxide (aq)	60 (140)	2	4	4	4
Potassium nitrate (aq)	RT / 60 (140)	1	1	1	1
Potassium sulfate (aq)	RT / 60 (140)	1	1	4	1
Propane	RT	1	1	1	4
Propyl acetate	RT	4	4	4	4
Propyl alcohol	RT / 60 (140)	1	1	4	1
Propylene	RT	4	1	4	4
Propylene oxide	RT	4	4	4	4
Prussic acid (hydrocyanic acid)	RT	2	1	4	3
Pyridine	RT	4	4	4	4
Pyroigneous acid	RT	4	4	4	5
Pyrrole	RT	4	4	4	2
R					
Rapeseed oil	RT	2	1	2	4
Refrigerants (acc. to DIN 8962)					
– R 11	RT	2	1	5	4
– R 12	RT	1	2	1	4
– R 13	RT	1	1	5	4

Chemical resistance

Medium	Temperature	Medium's effect on sealing lip material			
		R, D, H	V	P	S
–	°C (°F)	–			
– R 13 B1	RT	1	1	5	4
– R 14	RT	1	1	5	4
– R 21	RT	4	4	5	4
– R 22	RT	4	4	2	4
– R 31	RT	4	4	5	5
– R 32	RT	1	4	5	5
– R 112	RT	3	1	5	4
– R 113	RT	1	2	5	4
– R 114	RT	1	2	5	4
– R 114 B2	RT	2	2	5	4
– R 115	RT	1	2	5	5
– R C 318	RT	1	2	5	5
S					
Salicylic acid	RT	2	1	5	5
Sea water	RT	1	1	4	1
Silver nitrate (aq)	RT	2	1	1	1
Soap solution	RT	1	1	4	1
Sodium acetate (aq)	RT	2	4	4	4
Sodium bicarbonate (aq)	60 (140)	1	1	5	1
Sodium bisulphite (aq)	100 (210)	1	1	4	1
Sodium carbonate (soda)	RT / 60 (140)	1	1	5	1
Sodium chloride (aq)	RT / 100 (210)	1	1	5	1
Sodium cyanide (aq)	RT	1	1	5	1
Sodium hydroxide (aq)	RT	2	2	3	2
Sodium hypochlorite (aq)	RT / 50 (120)	2	1	4	5
Sodium metaphosphate	RT / 60 (140)	1	1	5	2
Sodium nitrate (aq)	RT / 60 (140)	2	5	5	4
Sodium phosphate (aq)	RT / 60 (140)	1	1	4	4
Sodium silicate (aq)	RT / 60 (140)	1	1	5	5
Sodium sulphate (aq) (Glauber's salt)	RT / 60 (140)	1	1	4	1
Sodium thiosulphate (aq)	RT / 50 (120)	2	1	4	1
Soybean oil	RT	1	1	1	1
Stannic chloride (aq)	RT / 80 (175)	1	1	5	2
Stannous chloride (aq)	RT / 80 (175)	1	1	5	2
Steam	below 150 (300)	4	4	4	3
Steam	above 150 (300)	4	4	4	4
Stearic acid	60 (140)	2	2	4	2
Stoddard solvent	RT	1	1	1	4
Styrene	RT	4	2	4	4
Sucrose solution	RT / 60 (140)	1	1	4	1
Sulphur	RT / 60 (140)	4	1	4	3
Sulphur chloride (aq)	RT	3	1	4	3
Sulphur dioxide (dry)	RT / 60 (140)	4	1	4	2
Sulphur dioxide (liquified)	RT / 60 (140)	4	1	4	2
Sulphur dioxide (wet)	RT / 60 (140)	4	1	4	2
Sulphur hexafluoride	RT	2	1	4	2
Sulphuric acid (conc.)	RT / 50 (120)	4	1	4	4
Sulphuric acid (20%) (battery acid)	60 (140)	4	1	4	4
Sulphuric acid (dilute)	RT	3	1	2	4
Sulphurous acid	RT / 60 (140)	4	1	4	4
Sulphur trioxide	RT	4	1	4	2
T					
Tannic acid	RT / 60 (140)	1	1	4	2
Tar, bituminous	RT	2	1	4	2
Tartaric acid	60 (140)	1	1	5	1
Tepineol	RT	2	1	5	5
Tetrabromoethane	RT	4	1	4	4
Tetrabromomethane	RT	4	1	5	4
Tetrabutyl titanate	RT	2	1	5	5
Tetrachloroethylene	60 (140)	4	2	4	4
Tetraethyl lead	RT	2	1	5	5
Tetrahydrofuran	RT	4	4	4	4
Tetrahydronaphthalene (Tetralin)	RT	4	1	5	4
Thionyl chloride	RT	4	2	4	5

Chemical resistance

Medium	Temperature	Medium's effect on sealing lip material			
		R, D, H	V	P	S
–	°C (°F)	–			
Titanium tetrachloride	RT	2	1	4	4
Toluene	RT	4	1	4	4
Toluene diisocyanate	RT	4	4	4	4
Triacetin	RT	2	1	4	5
Tributoxy ethyl phosphate	RT	4	1	4	5
Tributyl phosphate	RT / 60 (140)	4	4	4	4
Trichloroacetic acid	60 (140)	5	4	4	4
Trichloroethane	RT	4	1	4	4
Trichloroethylene	RT	4	1	4	4
Tricresyl phosphate	RT / 60 (140)	4	1	4	3
Triethanol amine	RT	2	4	4	5
Triethyl aluminium	RT	4	2	4	5
Triethyl borane	RT	4	1	4	5
Trinitrotoluene	RT	4	2	4	5
Trioctyl phosphate	RT / 60 (140)	4	2	4	3
Tung oil (China wood oil)	RT	1	1	1	4
Turpentine	RT	1	1	2	4
V					
Varnish	RT	2	1	4	4
Vegetable oil	60 (140)	1	1	1	2
Vinyl acetylene	RT	1	1	5	2
Vinyl chloride	RT	4	1	5	5
W					
Water	100 (210)	1	1	4	1
Whisky	RT	1	1	4	1
White oil	RT / 80 (175)	1	1	1	4
Wine	RT	1	1	4	1
Wood oil	RT	1	1	1	4
X					
Xylene	RT	4	1	4	4
Xylidine (di-methyl aniline)	RT	3	4	4	4
Z					
Zeolites	RT	1	1	5	5
Zinc acetate (aq)	RT	1	1	4	4
Zinc chloride (aq)	RT	1	1	4	1
Zinc sulphate (aq)	RT	1	1	4	1

Storage and handling of seals

General

The following guidelines for the storage and cleaning of seals are valid for natural and synthetic elastomer materials and are in accordance with ISO 2230 and DIN 7716 standards. The storage guidelines set forth in DIN 7716 are valid for long-term storage.

Unfavourable storage conditions and improper handling can change the physical properties of most products made from natural or synthetic rubber. This can result in hardening or softening, permanent deformation, peeling or cracks, which can lead to a shortened service life or render the products altogether useless. These changes can be brought about by storing the products under stress or load or from the influence of oxygen, ozone, heat, light, moisture or solvents. When stored properly, elastomer products generally retain their properties for several years.

Storage

The storage area should be cool, dry, moderately ventilated and there should be as little dust as possible. Outdoor storage without protection should be avoided.

The appropriate storage temperature depends on the elastomer. The most favourable storage temperature for synthetic rubber seals is 15 to 25 °C (60 to 80 °F).

Elastomer products that have been subjected to low temperatures during transport or storage may become stiff. They should therefore be warmed and kept at a temperature of at least 20 °C (70 °F) before being unpacked and used in order to prevent exposure to condensation.

In heated storage rooms, the products should be shielded from the heat source. There should be at least 1 m (3 ft.) between the packages and the source of heat. In rooms where a heater with a fan is used, the distance should be greater. Storage in damp rooms should be avoided because of the risk of condensation. A storage facility with relative humidity below 65% is excellent.

Seals should be protected from light, particularly direct sunlight or artificial light with a high proportion of UV radiation. Any windows in the store should therefore be covered with a red or

orange coating (never blue). Ordinary light bulbs are preferred for illumination.

Seals should be wrapped or stored in airtight containers, protecting them from atmospheric changes and particularly against drafts.

Because ozone is particularly damaging, steps must be taken to make sure that no ozone is produced in the storage facility as the result of using electric motors or other equipment that can produce sparks or other electric discharges. Combustion fumes and vapours that can produce ozone as the result of photochemical processes should be exhausted. For this reason, solvents, fuels, lubricants, chemicals, acids, disinfectants etc. should not be stored in the same room as the seals.

Elastomer products should not be subjected to tension, compression or other forms of load during storage as this can produce permanent deformations and cracks. Seals should therefore not be hung on hooks during storage. Certain metals, especially copper and manganese, damage elastomer products. Contact with these metals should therefore be avoided and the seals should be covered with layers of paper or polyethylene to prevent such contact.

In case it is necessary to repack the seals, packaging and covering materials should not contain substances such as copper or alloys containing copper, petroleum, oil etc. that can cause damage to the seals. The packaging materials should not contain softeners.

If the products are powdered, suitable powders are talcum, chalk, finely divided glimmer and rice starch.

Seals made of different materials should not be in contact with each other. This is particularly important when the seals are different in colour as this will avoid discolouration.

Seals should be stored for the shortest period of time possible. Where long-term storage is involved, care should be taken that newly arrived products are kept separate from those already in storage to enable use of seals on a first in, first out basis.

Cleaning and maintenance

In the event that cleaning is necessary, elastomer products should be cleaned with warm, soapy water that does not exceed 30 °C (85 °F), and air dried at room temperature.

Solvents such as trichloroethylene, carbon tetrachloride or hydrocarbons should not be used, nor should sharp-edged objects, wire brushes, emery cloth or sandpaper.

Elastomer/metal combinations can be cleaned using a 1:10 mixture of glycerine and alcohol.



Radial shaft seals

General	50
Outside diameter design	54
SKF Bore Tite Coating	54
Garter springs	55
Dimensions	55
Tolerances	55
Sealing lip design	57
Auxiliary lips	58
Coaxiality and runout	59
Coaxiality	59
Runout	61
Axial movement	63
Permissible speed	63
Lubrication	65
Lubrication of paired arrangements	65
Friction	66
Chemical and thermal resistance	67
Seals under pressure	69
Shaft requirements	70
General	70
Tolerances	70
Surface roughness	70
Surface finish	72
Hardness and surface treatment	72
Lead-in chamfers	72
Housing bore requirements	74
General	74

Tolerances	76
Surface roughness	76
Seal installation, general industrial applications	77
General	77
Seal installation, heavy industrial applications	79
Metal-reinforced seals	79
Seals without metal reinforcement	80
Split seals	80
Cover plates	82
Multiple HS seal installations	83
Multiple HDS seal installations	84
PTFE seals	85
Protecting the counterface surface against corrosion	87
Removal	87
Replacement	87
Designation system	88
Metric radial shaft seals	88
Inch-size radial shaft seals	88
Assortment and availability	88
Seals for general industrial applications	92
HMS5 and HMSA10 seals	92
2.1 Product table: HMS5 and HMSA10	94
CRW1, CRWA1, CRWH1 and CRWHA1 seals	100
2.2 Product table: CRW1, CRWA1, CRWH1 and CRWHA1	101
CRW5 and CRWA5 seals	156
2.3 Product table: CRW5 and CRWA5	157
HDW1 seals	160
2.4 Product table: HDW1	161
HMS4 and HMSA7 seals	162
2.5 Product table: HMS4 and HMSA7 seals	163
CRS1, CRSH1, CRSA1 and CRSHA1 seals	170
2.6 Product table: CRS1, CRSH1, CRSA1 and CRSHA1	171
PTFE radial shaft seals	178
HM and TL seals for grease lubricated applications	182
2.7 Product table: HM and TL seals	183
X seals, sealing against housing bore	196
2.8 Product table: X seals	197
Seals for heavy industrial applications	206
General	206
Metal-cased seals	206
Rubber outside diameter seals	211
Additional design features	215
Size options of metal-cased HDS seals and all-rubber HS seals	219

Product tables	220
2.9 HDS7	220
2.10 HDS7K	226
2.11 HDL	230
2.12 HDS1, HDS2 and HDS3	246
2.13 HDS1K	262
2.14 HDS2K	264
2.15 HDSF and HDSH seals	266
2.16 HDSA, HDSB and HDSC seals	268
2.17 HDSE1	274
2.18 HDSD and HDSE seals	276
2.19 SBF	278
2.20 HSF1 (split) and HSF5 (solid)	280
2.21 HSF2 (split) and HSF6 (solid)	294
2.22 HSF3 (split) and HSF7 (solid)	296
2.23 HSF4 (split) and HSF8 (solid)	302
2.24 HSF9	304
2.25 HS4 and HS5	306
2.26 HS6, HS7 and HS8	310



Radial shaft seals

General

Radial shaft seals are used between rotating and stationary machine components (→ **fig. 1**) or between two components in relative motion and consist of two main parts:

- A cylindrical outer covering of sheet steel (case) or an elastomer that has the requisite interference fit to seal statically against the housing bore.
- A sealing lip made of an elastomeric or thermoplastic material that seals dynamically and statically against the shaft. The lip has a sealing edge that is formed by moulding, cutting or grinding. It is normally pressed against the counterface surface of the shaft, with a defined radial load, by a garter spring. The edge of the sealing lip and the shaft counterface surface form the most important functional area of a radial shaft seal. The sealing effect of the lip can be enhanced by designing the contact area of the lip with hydrodynamic features.

Fig. 1

Radial shaft seal, HMS5



Some radial shaft seal designs have an auxiliary lip that protects the primary sealing lip from dust and other contaminants. A suitable lubricant in the space between the primary sealing lip and the auxiliary lip can reduce wear and delay corrosion. Contaminants that have passed the auxiliary lip will eventually cause damage in the counterface surface area. A build-up of heat can also occur between the two lips, resulting in premature wear.

Radial shaft seals are used in a multitude of applications. Because of the importance of radial shaft seals for the operational reliability and service life of machines and equipment, both seal manufacturers and users are equally interested, to some degree, in standardization. This has led to the establishment of national and international standards and guidelines listed in **table 1** on **page 53**. These cover boundary dimensions, tolerances, material specifications, test methods and terminology as well as the basic outside diameter constructions and sealing lip arrangements.

See **figs. 2** and **3** on **page 52** for the terminology used in this publication.

Fig. 2

Metal-cased seal with spring-loaded sealing lip

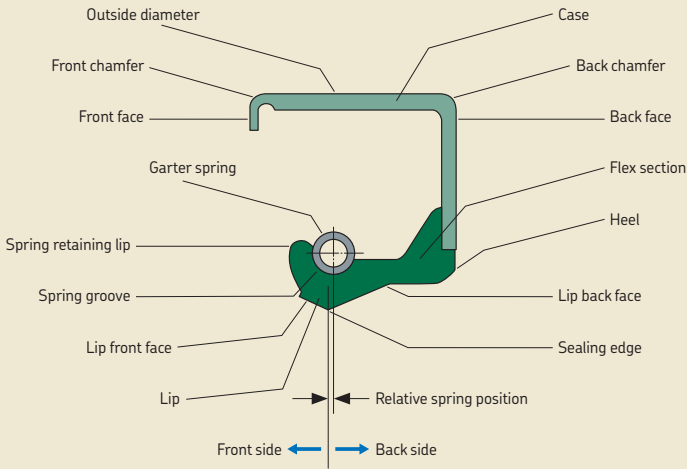
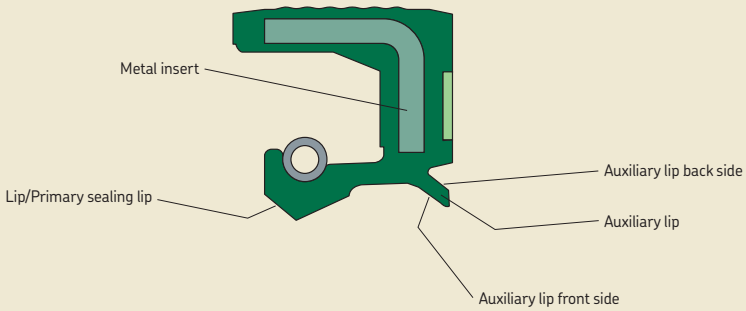

Fig. 3

Rubber outside diameter seal with spring-loaded sealing lip and auxiliary lip



Standards and other documents relating to radial shaft seals

Document ¹⁾	Title
ISO 2230	Rubber products – guidelines for storage
ISO 6194-1	Rotary shaft lip-type seals – Nominal dimensions and tolerances
ISO 6194-2	Rotary shaft lip-type seals – Vocabulary
ISO 6194-3	Rotary shaft lip-type seals – Storage, handling and installation
ISO 6194-4	Rotary shaft lip-type seals – Performance test procedures
ISO 6194-5	Rotary shaft lip-type seals – Identification of visual imperfections
SAE J946	Application guide to radial lip seals
RMA OS-1-1	Shaft requirements for rotary shaft seals
RMA OS-4	Application guide for radial lip type shaft seals
RMA OS-7	Storage and handling guide for radial lip type shaft seals
RMA OS-8	Visual variations guide for rotating shaft seals
DIN 3760	Radial-Wellendichtringe (Radial shaft seals)
DIN 3761	Radial-Wellendichtringe für Kraftfahrzeuge (Radial shaft seals for motor vehicles), Parts 1 to 15. This standard covers all aspects including vocabulary, material requirements and test methods.
DIN 7172	Tolerances and limit deviations for sizes above 3 150 mm up to 10 000 mm.
DIN 7716	Rubber products; requirements for storage, cleaning and maintenance.

¹⁾ RMA = Rubber Manufacturers Association
 SAE = Society of Automotive Engineers
 ISO = International Organization for Standardization
 DIN = Deutsches Institut für Normung

Outside diameter design

The standard assortment of radial shaft seals manufactured by SKF for general industrial applications covers three different outside diameter executions (→ **figs. 4a** to **4c**).

Seals with a rubber outside diameter (→ **fig. 4a**) are used in a wide range of applications. They maintain a tight fit in the housing bore when the housing material has a higher coefficient of thermal expansion than steel and/or when the housing is split. They are also recommended in all applications where the housing bore surface finish requirements cannot be met.

Metal-cased seals (→ **fig. 4b**) are multi-purpose seals that can be used for most applications. They are relatively easy to install and, provided the housing bore meets the requirements, will fit tightly and centrally in the housing bore.

Radial shaft seals designed with a metal case and a secondary reinforcement in the side face (→ **fig. 4c**) offer advantages where operating conditions are severe. They have a higher radial stiffness and are available for shaft diameters ≥ 50 mm (2 in.).

Besides these standard outside diameter designs, there is also a half rubber/half metal outside diameter design (→ **fig. 4d**) that is typically used in automotive applications.

In addition to the seal designs for general industrial applications described above, SKF also manufactures seals for heavy industrial applications with special features to meet specific requirements (→ **page 206**).

SKF Bore Tite Coating

As the static sealing ability between a metal outside diameter and the housing bore is somewhat limited, particularly in the case of low-viscosity fluids and media that can “creep”, most SKF seals with a metal case feature SKF Bore Tite Coating, a water-based acrylic sealant. SKF Bore Tite Coating is green in colour, does not harden and serves to fill small imperfections in the housing bore. For additional details, refer to **page 29**.

Fig. 4

Outside diameter designs

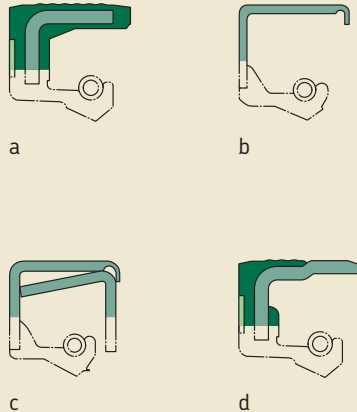

Garter springs

SKF radial shaft seals have garter springs made of drawn carbon steel or stainless steel spring wire. Carbon steel springs are standard unless otherwise specified.

Dimensions

SKF radial shaft seals are manufactured for a wide range of shaft diameters, from 5 to 4 600 mm (*0.2 to 181 in.*). The range also includes standard sizes in accordance with ISO 6194-1 and DIN 3760 for shafts ranging from 6 to 500 mm (*0.24 to 19.7 in.*).

Tolerances

SKF radial shaft seals are manufactured to the outside diameter tolerances listed in **table 2** on **page 56**, for metric seals, and **table 3** on **page 56** for inch-size seals. These are, where standardized, in accordance with ISO 6194-1, DIN 3760 and RMA OS-4.

Radial shaft seals

Table 2

Outside diameter tolerances for metric seals

Nominal seal outside diameter		Seals with outside diameter of steel		elastomer	
D over	incl.	Seal outside diameter high	Seal outside diameter low	Seal outside diameter high	Seal outside diameter low
mm		mm		mm	
50	80	+0,20	+0,08	+0,30	+0,15
80	120	+0,23	+0,09	+0,35	+0,20
		+0,25	+0,10	+0,35	+0,20
120	180	+0,28	+0,12	+0,45	+0,25
180	300	+0,35	+0,15	+0,45	+0,25
300	500	+0,45	+0,20	+0,55	+0,30
500	630	+0,50	+0,22	–	–
630	800	+0,50	+0,24	–	–
800	1 000	+0,55	+0,25	–	–
1 000	1 250	+0,60	+0,27	–	–
1 250	1 600	+0,65	+0,30	–	–

Contact SKF for sizes outside the listed range.

Table 3

Outside diameter tolerances for inch-size seals

Bore diameter ¹⁾			Seals with outside diameter of steel		elastomer	
D over	incl.	Tolerance	Nominal seal outside diameter	Seal outside diameter tolerance	Nominal seal outside diameter	Seal outside diameter tolerance
in.			in.		in.	
	2.000	±0.001	+0.005	±0.002	+0.008	±0.003
2.000	3.000	±0.001	+0.0055	±0.0025	+0.01	±0.003
3.000	4.000	±0.0015	+0.0065	±0.003	+0.0105	±0.003
4.000	5.000	±0.0015	+0.0065	±0.003	+0.0105	±0.003
5.000	7.000	±0.0015	+0.007	±0.003	+0.012	±0.004
7.000	9.000	±0.002	+0.0085	±0.0035	+0.0125	±0.004
9.000	10.000	±0.002	+0.0085	±0.0035	+0.0125	±0.004

¹⁾ Housing bores made of material other than steel may need a different nominal press-fit tolerance due to differences in thermal coefficients of expansion.

Contact SKF for sizes outside the listed range.

Sealing lip design

The form and design of a sealing lip is based on knowledge gained through research and development activities as well as wide practical experience obtained by SKF in close cooperation with users. The distance between the lip and the seal back face, the strength of the flex section, the angle of the lip (→ **fig. 2** on **page 52**) and the tension in the spring are all balanced so that the pressure applied by the garter spring provides a satisfactory sealing performance between the sealing lip and counterface.

The sealing lips of SKF radial shaft seals are manufactured from several materials and two different main designs. The various materials are described on **pages 30 to 32**. There are two main sealing lip designs that differ in the execution of the sealing lip edge. The “conventional” sealing lip (→ **fig. 5**) has a straight edge, whereas the SKF WAVE lips (→ **fig. 6**) are moulded with a hydrodynamic feature that results in the lip taking a sinusoidal path on its counterface surface.

SKF WAVE seals represent one of the most important developments in radial shaft seals. The sealing lip is moulded to a special form, producing a relative movement on the counterface, imparting hydrodynamic properties. SKF WAVE seals are suitable for rotation in both directions. They pump the lubricant back into the bearing arrangement and expel contaminants. The sinusoidal form of the sealing lip considerably extends the path (→ **fig. 6**) on the counterface surface and at the same time reduces the specific surface pressure at the sealing lip/counterface contact.

Fig. 5

Conventional sealing lip with straight edge

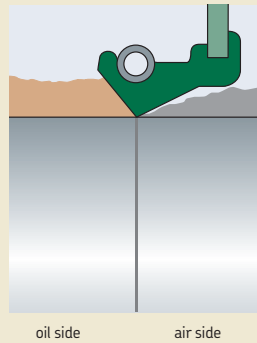
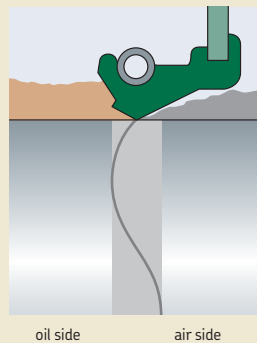

Fig. 6

SKF WAVE sealing lip with sinusoidal sealing lip edge



Radial shaft seals

As a consequence, SKF WAVE seals produce up to 20% less friction resulting in up to 30% lower temperatures than conventional lip designs (→ **diagrams 1 and 2**). Reduced friction and the sinusoidal path of the sealing lips help prevent the formation of deep tracks in the counterface, resulting in significantly extended service life. SKF WAVE seals are recommended where demands for operational reliability and long service life for machines and equipment are high.

SKF seals with conventional spring-loaded sealing lips meet general demands because they are able to provide efficient sealing even under unfavourable operating conditions. To improve sealing performance, some SKF radial shaft seals are designed with hydrodynamic features on the sealing lip. These have either a right-hand twist for shafts that rotate clockwise, or a left-hand twist for shafts that rotate counter-clockwise as seen from the air side. The degree to which the hydrodynamic feature improves the sealing ability depends on the form of the spiral flutes, the circumferential speed, the pressure conditions and the media being sealed. See also paragraph *Oil retention* on **page 18**.

Auxiliary lips

SKF radial shaft seals can also be designed with an auxiliary lip for increased protection against contaminants (→ **fig. 3 on page 52**). These auxiliary lips are either contacting or non-contacting. Seal designs that incorporate contacting auxiliary lips are used in heavily contaminated environments, with the drawback, however, of creating increased friction and elevated underlip temperatures. The auxiliary lip of HMSA10 and CRWA1/CRWHA1 seals is non-contacting, which means that these designs normally can be used at the same speeds as the single-lip designs HMS5 and CRW1/CRWH1.

Diagram 1

Temperature rise at sealing lip/counterface contact for conventional and SKF WAVE lips as a function of rotational speed for a 76 mm diameter shaft with SAE 30 engine oil

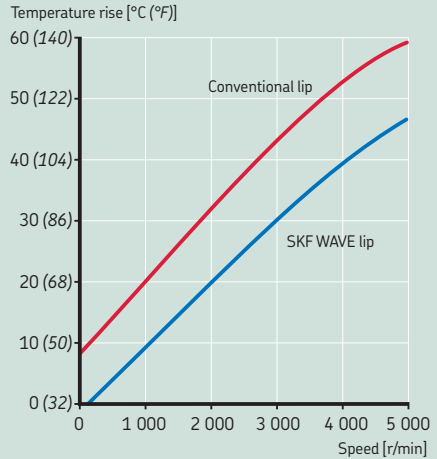
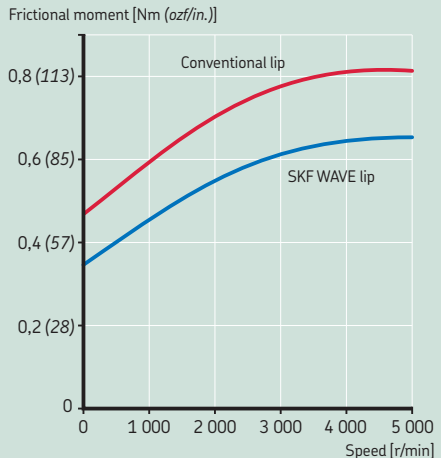

Diagram 2

Frictional moment at sealing lip/counterface contact for conventional and SKF WAVE lips as a function of rotational speed for a 76 mm diameter shaft with SAE 30 engine oil



Coaxiality and runout

Deviation from coaxiality and dynamic runout of the shaft are two of many operating parameters that affect seal performance and service life. They should therefore be kept within narrow limits, particularly when there is a pressure differential across the seal. The total deviation should never exceed 1,3 times the value of the permissible deviation from coaxiality.

Coaxiality

Deviations from coaxiality, i.e. the difference between the centre lines of the shaft and housing bore (shaft -to-bore misalignment, STBM), cause force to be distributed irregularly on the sealing lip (\rightarrow fig. 7). This means that one section of the sealing lip will be subjected to more force, causing an enlargement of the contact area between lip and counterface surface, whereas the opposite section will be correspondingly unloaded and its sealing effect reduced. Guideline values for the permissible coaxiality deviations for SKF seals can be obtained from **diagram 3** on **page 60**.

2

Fig. 7

Coaxiality

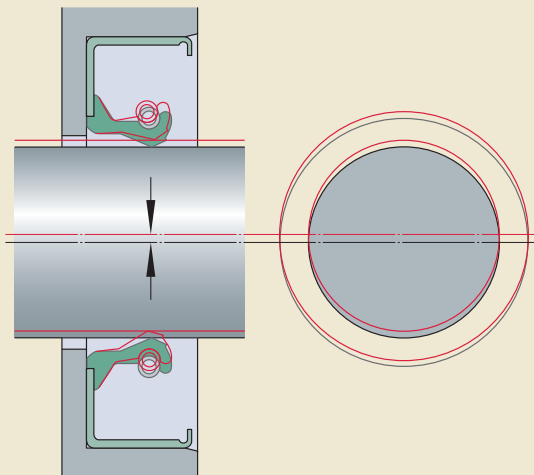

Radial shaft seals

Diagram 3

Maximum permissible deviation from coaxiality as a function of shaft diameter

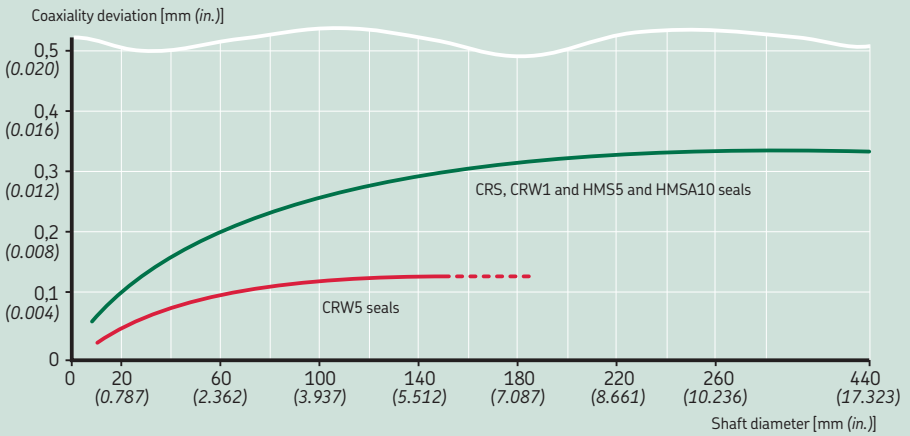
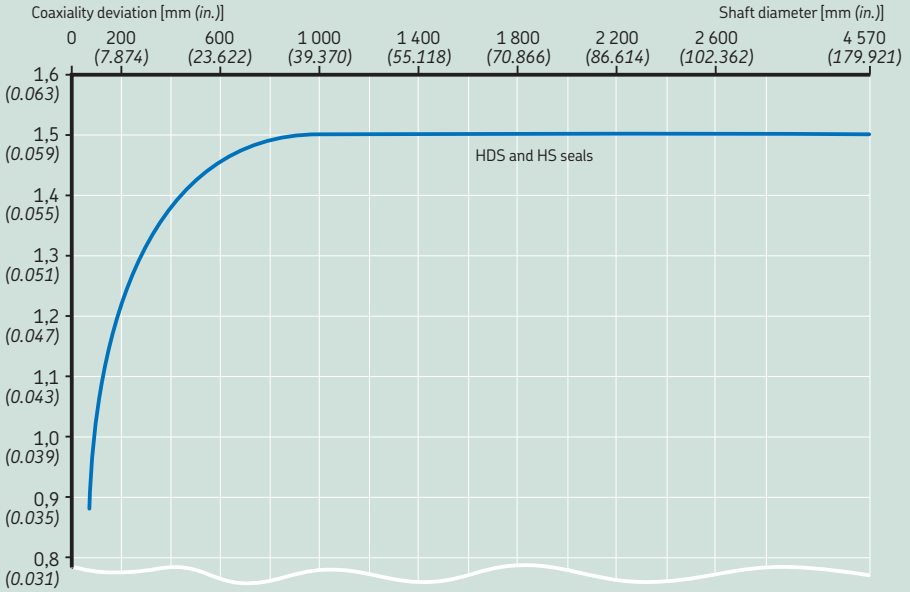

Runout

Runout (or dynamic runout, DRO) describes the dynamic eccentricity of the shaft. Particularly at high speeds, there is a risk that the sealing lip, because of its inertia, will not be able to follow the shaft surface (→ **fig. 8**). If the eccentricity is such that the distance between the sealing lip and shaft becomes larger than that required to maintain a hydrodynamic lubricant film, the medium to be sealed will escape through the gap. It is therefore advisable to arrange the seal in close proximity to the bearing and to keep bearing operating clearance to a minimum. Permissible runout values can be obtained from **diagram 4** on **page 62**. These values are normally lower for narrow seals.

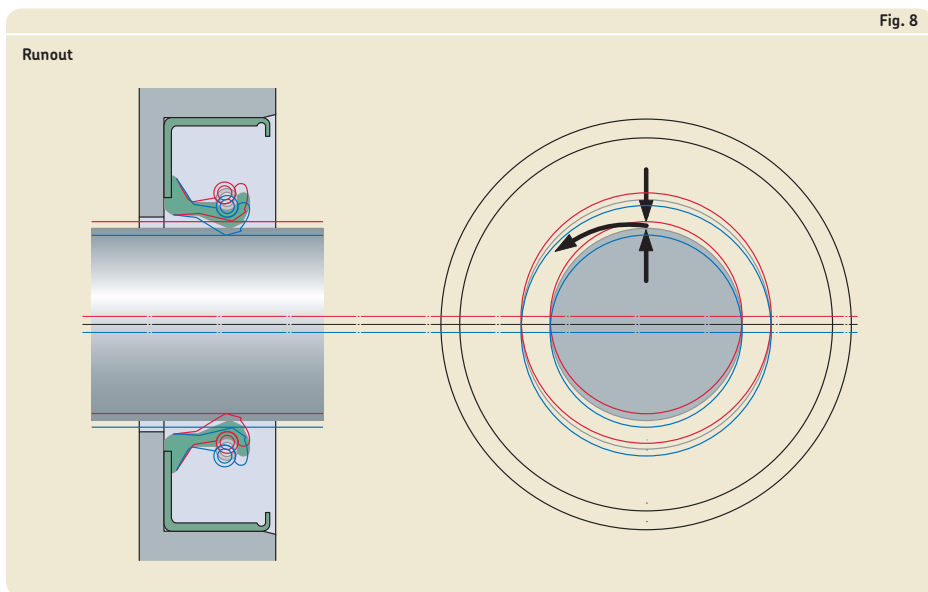

Maximum permissible runout as a function of rotational speed

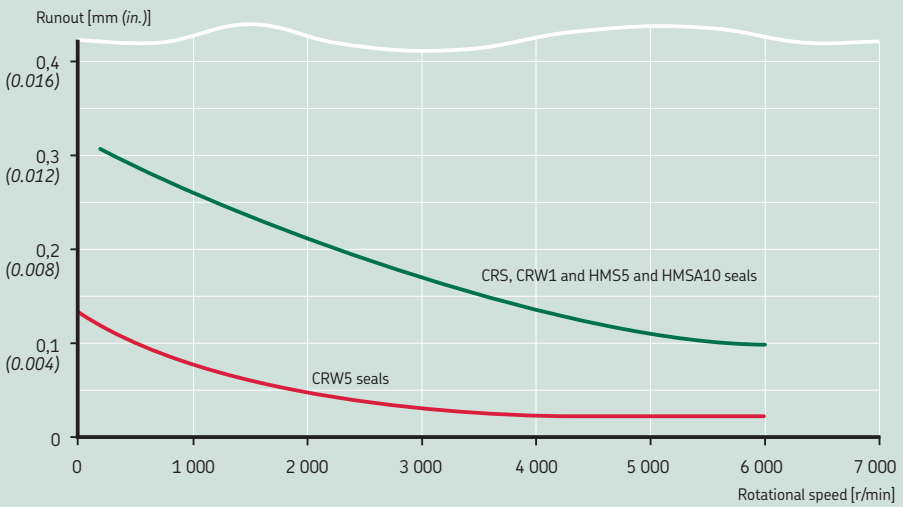
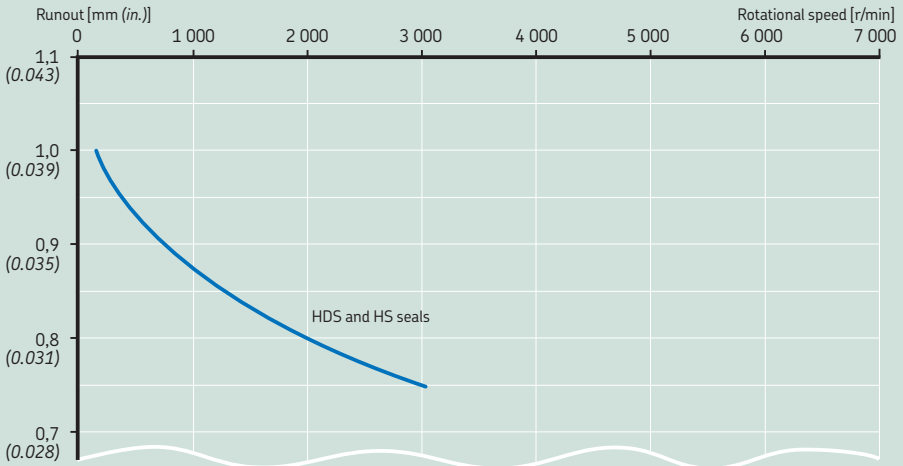

Axial movement

Small movements of the shaft relative to the housing in the axial direction do not affect seal performance, provided that the total counterface surface meets the same demands relative to hardness, accuracy and surface finish.

Permissible speeds

Guideline values for the permissible rotational and circumferential speeds for different seal designs are provided in the seal selection charts (**matrix 2** on **pages 202 to 205**). If the circumferential speeds provided in the matrix are not sufficient for a particular sealing position, **diagram 5** from DIN 3760 on **page 64** may be used. The diagram lists circumferential and rotational speeds related to the material of the sealing lip. The values are valid for spring-loaded sealing lips that are well-lubricated by a mineral oil, where adequate lubricant supply prevents heat build-up and where the pressure is the same on both sides of the seal (pressure differential = 0).

Diagram 5 shows that large diameter shafts can accommodate higher circumferential speeds than shafts with smaller diameters. This is because the cross section of the shaft does not increase linearly with the increase in diameter but by the square of the increase in diameter. Therefore, the heat dissipation of a large shaft is much better than that of a small shaft.

Generally, SKF WAVE seals can be operated at higher circumferential speeds than those obtained from **diagram 5** because of the hydrodynamic form of the lip.

The values obtained from **diagram 5** should be reduced if:

- radial shaft seals with an auxiliary, contacting lip are used
- lubrication is inadequate or grease lubrication is used, i.e. when underlip temperatures increase due to poor heat dissipation
- the counterface does not meet surface finish or running accuracy requirements
- there is a pressure differential across the seal

Radial shaft seals

Diagram 5

Permissible speeds for spring-loaded sealing lips where no pressure differential exists across seal in operation
 For permissible speeds for seals at shaft diameters > 200 mm, refer to seal selection chart starting on page 92.

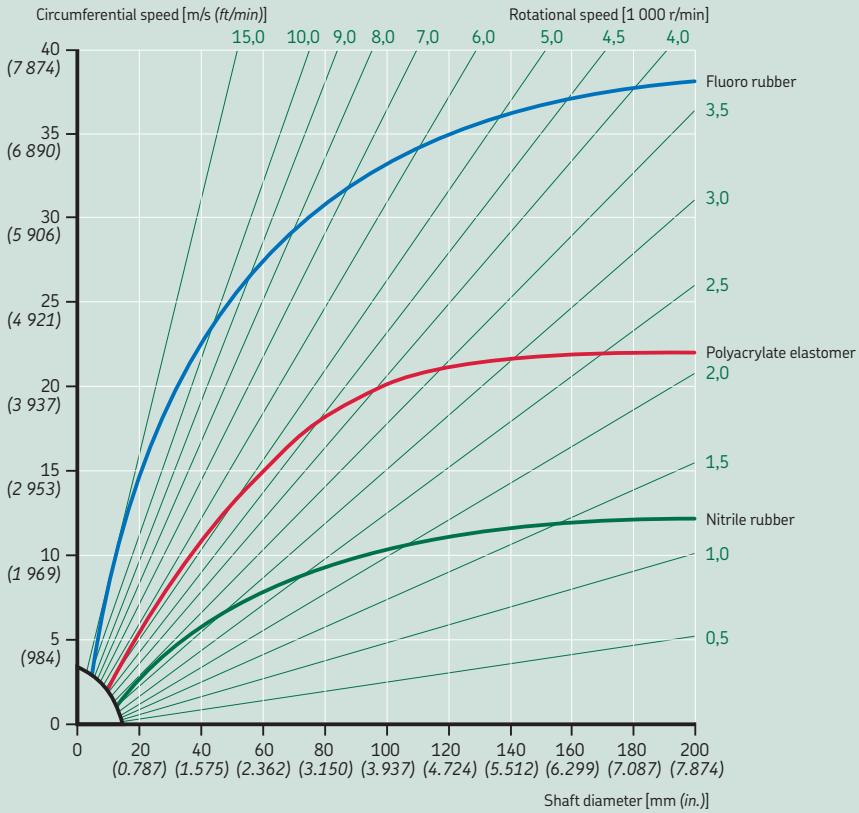

Source: DIN standard 3760

Lubrication

For a radial shaft seal to seal efficiently over a long period, the sealing lip must be lubricated. This reduces friction and wear to the sealing lip and shaft. Dry running of sealing lips made of standard materials should always be avoided. To prevent dry running, coat the counterface surface with a suitable lubricant prior to seal installation.

The lubricant must not only lubricate the sealing lip to reduce friction and wear, but also dissipate heat generated by the seal. To promote heat dissipation, a sufficient quantity of lubricant must be able to reach the sealing lip from start-up.

Some rolling bearings, such as angular contact ball bearings, tapered roller bearings and spherical roller thrust bearings, as well as gears, create a pumping action by virtue of their design. This means that the sealing lip can either be starved of lubricant, or subjected to excessive quantities of lubricant. In either case, steps must be taken during the design stage to make sure that the proper amount of lubricant reaches the sealing lip, as too much or too little can affect seal performance.

To prevent lubricant starvation, lubrication ducts can be provided. If the seal is subjected to excessive amounts of lubricant, a flinger can be installed between the bearing and seal.

In applications where the sealing lip is not exposed to a lubricant, for example when two seals are installed in tandem, grease or oil must be supplied separately to provide lip lubrication. In some cases, it may be sufficient to provide an initial grease fill between the two lips.

Lubrication of paired arrangements

When two radial shaft seals are installed back-to-back or in tandem, the space between the seals should be filled with a suitable lubricant to eliminate the risk of the sealing lip running dry.

To further prevent dry running, a spacing washer between the seals can also be used. This spacing washer should be provided with lubrication holes or an annular groove and lubrication holes so that grease can be supplied to the space between the seals via a grease fitting (→ fig. 9).

2

Fig. 9

Lubrication of a paired arrangement

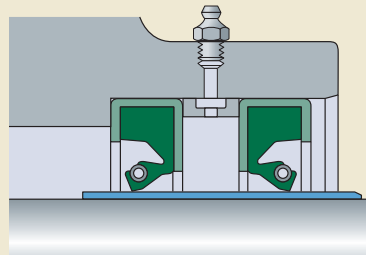

Friction

To be effective, the lip of a radial shaft seal must always exert a certain radial load on the counterface. The friction resulting from this radial load is only part of the total contact friction and power loss at the sealing position. Other contributing factors include:

- type of medium being sealed
- pressure differential across the seal
- circumferential speed
- ambient temperature
- lubricant and lubrication method
- condition of the counterface

Diagram 6 provides an indication of the friction losses that may be expected when a radial shaft seal with a conventional sealing lip is properly installed and fully lubricated.

The running-in phase of the sealing lip lasts a few hours. During this time, the friction losses are somewhat higher than during normal operation.

Seals intended for applications with high pressure differentials typically have greater losses than specified in the diagram. SKF WAVE seals, on the other hand, typically have losses lower than those indicated in the diagram.

Diagram 6

Friction losses of radial shaft seals as a function of rotational speed and shaft diameter

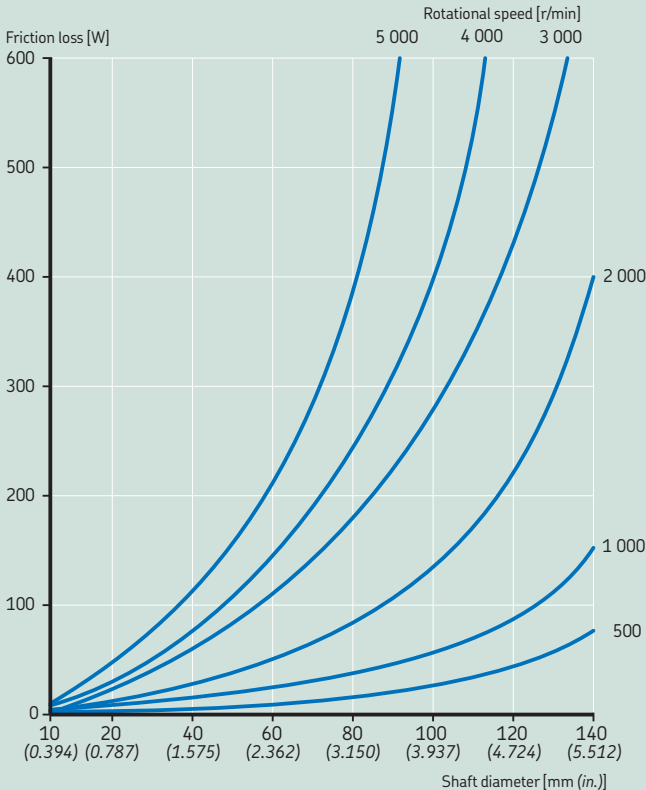

Chemical and thermal resistance

The most important factor when selecting the appropriate elastomer for a radial shaft seal is its chemical resistance to the medium to be sealed or excluded. The operating temperature is another important factor. Heat accelerates ageing of the elastomer and increases the reactivity and aggressiveness of the sealed medium.

Radial shaft seals are mainly used to seal lubricating oils and greases as well as hydraulic fluids (including non-flammable fluids). Guideline values are provided in **table 4** on **page 68** for the permissible operating temperatures, i.e. temperatures at which the SKF seals are still chemically resistant. The temperature range stated for a group of media means that the sealing material is resistant when continuously operated within this particular range.

The □ means that, within the group, there are some media that are compatible with the elastomer, but also some that have a detrimental effect on the elastomer.

The ■ means that the seal material is not resistant to media belonging to this group.

For the resistance of seal materials to media not listed in **table 4** on **page 68**, refer to the section *Chemical resistance* (→ **page 35**) or contact SKF.

Table 4

Chemical and thermal resistance, radial shaft seal lip materials

Medium to be sealed	Permissible operating temperatures (continuous) for SKF radial shaft seal lip materials ¹⁾							
	R (NBR)		P (ACM)		S (MVQ)		V (FKM)	
	°C	°F	°C	°F	°C	°F	°C	°F
–								
Mineral oil based lubricants								
Motor oils	100	210	130	270	150	300	170	340
Gear oils	80	175	120	250	130	250	150	300
Hypoid gear oils	80	175	120	250	■		150	300
Automatic transmission fluids (ATF oils)	100	210	130	270	□		170	340
Greases	90	195	□		□		□	
Hydraulic fluids	90	195	120	250	□		150	300
Fire resistant hydraulic fluids								
Oil in water emulsions and aqueous polymer solutions	70	160	■		60	140	□	
Anhydrous fluids	■		■		■		150	300
Other media								
Fuel oils EL and L	90	195	□		■		□	
Water	90	195	■		■		100	210
Alkaline washing solutions	90	195	■		■		100	210
Permissible temperature range for sealing lip								
min:	–40	–40	–40	–40	–60	–75	–40	–40
max:	+100	+210	+150	+300	+160	+320	+200	+390

- Lip material not resistant
- Lip material not resistant to some media in this group

¹⁾ R = nitrile rubber
P = polyacrylate elastomer
S = silicone rubber
V = fluoro rubber

Seals under pressure

When a seal is exposed to pressure, the radial load of the sealing lip increases. This in turn increases the actual sealing lip/shaft contact area, resulting in additional friction and elevated underlip temperatures. Therefore, the guideline values for speeds provided in **diagram 5** on **page 64** do not apply.

Diagram 7 shows an example of lip distortion of a conventional sealing lip design as sump pressure increases, resulting in reduced seal service life.

SKF CRW5 and CRWA5 pressure profile seals (\rightarrow **fig. 10**) are designed to withstand pressure differentials of 0,34 MPa (50 psi) at speeds up to 5 m/s (1 000 ft/min).

When there is a pressure differential across the seal, a shoulder or retaining ring should be used at the low-pressure side of the seal to prevent it from being pressed out of the housing bore (\rightarrow **fig. 11**).

Fig. 10

Pressure profile seals

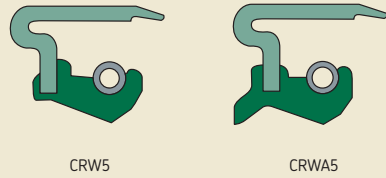

CRW5

CRWA5

Fig. 11

CRWA5 seal

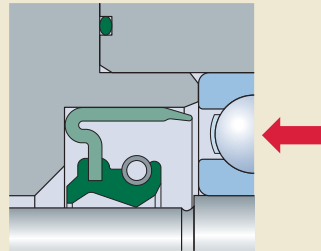
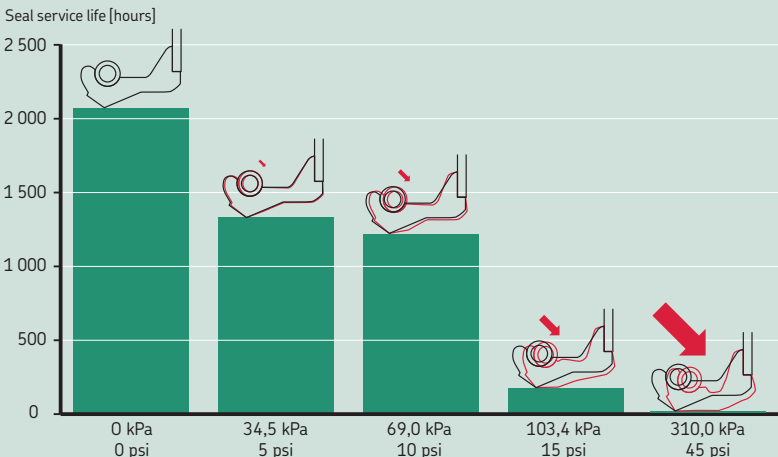

Diagram 7

Seals under pressure

Example of conventional sealing lip distortion as sump pressure increases, resulting in reduced seal service life.



Shaft requirements

General

To achieve reliable sealing performance and maximum service life, the counterface for a radial shaft seal should meet the requirements outlined below. The seal counterface must be able to accommodate all permissible deviations and movements – surface SL and an additional surface SL' – which may be required in the case of repairs or inspection (→ fig. 12).

In cases where a shaft cannot be machined to meet the requirements, SKF recommends the use of SKF SPEEDI-SLEEVE or a wear sleeve for heavy industrial applications (LDSL). Detailed information about sleeves is provided in the chapter *Wear sleeves* starting on page 331.

Tolerances

The diameter of the shaft d_1 at the counterface should be machined to the tolerances provided in table 6 for metric shafts and table 7 for inch-size shafts.

Out-of-roundness must be less than 0,005 mm (0.0002 in.) at a maximum of 2 lobes or less than 0,0025 mm (0.0001 in.) at a maximum of 7 lobes.

If components with an interference fit will pass over the counterface during installation, the shaft diameter should be reduced by 0,2 mm (0.008 in.). The seal that was originally chosen can still be used without adversely affecting seal performance.

Surface roughness

The surface roughness values of the counterface for radial shaft seals, calculated according to methods described in ISO 4288 (DIN 4768),

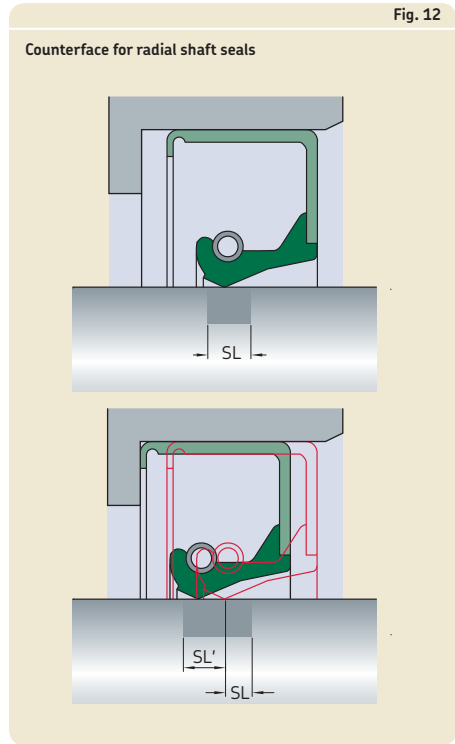

should be kept within the limits specified in RMA OS-1-1 (→ table 5).

The lower value for R_a is a minimum value. Using a lower value will adversely affect the lubricant supply to the sealing lip. The temperature rise caused by inadequate lubrication, particularly at high circumferential speeds, can lead to hardening and cracking of the sealing lip which will eventually lead to premature seal failure. If the counterface is too rough, there will be

Table 5

	ISO		DIN		RMA	
	μm	$\mu\text{in.}$	μm	$\mu\text{in.}$	μm	$\mu\text{in.}$
R_a	0,2–0,5	8–20	0,2–0,8	8–32	0,2–0,43	8–17
R_z	1,2–3	48–120	1–5	40–200	1,65–2,9	65–115
R_{pm}	N/A	N/A	N/A	N/A	0,5–1,5	20–50

Table 6

Counterface tolerances for metric shafts

Shaft diameter		Diameter tolerance (ISO h11) ¹⁾	
Nominal		Deviation	
d ₁		high	low
over	incl.		
mm		µm	
6	10	0	-90
10	18	0	-110
18	30	0	-130
30	50	0	-160
50	80	0	-190
80	120	0	-220
120	180	0	-250
180	250	0	-290
250	315	0	-320
315	400	0	-360
400	500	0	-400
500	630	0	-440
630	800	0	-500
800	1 000	0	-560
1 000	1 250	0	-660
1 250	1 600	0	-780
1 600	2 000	0	-920
2 000	2 500	0	-1 100
2 500	3 150	0	-1 350
3 150	4 000	0	-1 650
4 000	5 000	0	-2 000

¹⁾ For shaft diameters of 3 150 mm and above, refer to DIN 7172.

Table 7

Counterface tolerances for inch-size shafts

Shaft diameter		Diameter tolerance (RMA 05-4)	
Nominal		Deviation	
d ₁		high	low
over	incl.		
in.		in.	
	4	+0.003	-0.003
4	6	+0.004	-0.004
6	10	+0.005	-0.005
10		+0.006	-0.006

Radial shaft seals

excessive sealing lip wear and seal service life will be shortened. If the value R_{pm} is exceeded, the seal will leak or excessive sealing lip wear may occur.

Surface finish

Depending on the direction of rotation, directionality on the seal counterface may cause a seal to leak. Plunge grinding is the preferred machining method to minimize directionality ($0 \pm 0,05^\circ$) on the seal counterface. When plunge grinding, whole number ratios of the grinding wheel speed to the work piece speed should be avoided. Run the grinding wheel until it “sparks out” completely, i.e. until there are no more sparks flying from the wheel, to ensure that all lead is removed. The grinding wheel should be dressed using a cluster head dressing tool and the smallest possible lateral feed, or a profile dressing roll without lateral feed. The negative influence of directionality in any particular case can only be ascertained by test running under conditions of alternating rotation.

The seal counterface surface should be free of any damage, scratches, cracks, rust or burrs and should be properly protected until final installation.

Hardness and surface treatment

The surface hardness of the seal counterface should be at least 30 HRC (58 HRC for PTFE lip seals). If the counterface surface could be damaged during transport or installation, this value should be increased to 45 HRC (62 HRC for PTFE lip seals). Under certain conditions, where speeds are low, lubrication is good and contaminants are absent, counterface surfaces having a lower hardness may be suitable. Surfaces that are nitrided, phosphated or have a galvanized coating may also be suitable, but this must be determined for each specific case.

Lead-in chamfers

To install radial shaft seals without damaging the sealing lip, SKF recommends chamfering or rounding the shaft ends or shoulders (→ **table 8**).

If the direction of installation is Z, the values provided in **table 8** should be adhered to. If the direction of installation is Y, the shaft end should be rounded or chamfered.

To install a seal over a shaft shoulder or end that has not been rounded or chamfered, SKF recommends using an installation sleeve. See section *Seal installation, heavy industrial applications* on **page 79**.

Lead-in chamfers and radii

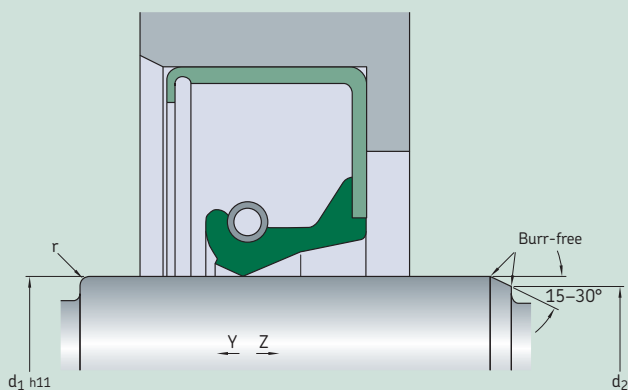

Shaft diameter Nominal				Diameter difference ¹⁾		Radii Seal without auxiliary lip		Seal with auxiliary lip	
d ₁ over	incl.	over	incl.	d ₁ - d ₂ min		r min		r min	
mm		in.		mm	in.	mm	in.	mm	in.
10	10		0.394	1,5	0.059	0,6	0.024	1	0.039
10	20	0.394	0.787	2	0.079	0,6	0.024	1	0.039
20	30	0.787	1.181	2,5	0.098	0,6	0.024	1	0.039
30	40	1.181	1.575	3	0.118	0,6	0.024	1	0.039
40	50	1.575	1.968	3,5	0.138	0,6	0.024	1	0.039
50	70	1.968	2.756	4	0.157	0,6	0.024	1	0.039
70	95	2.756	3.740	4,5	0.177	0,6	0.024	1	0.039
95	130	3.740	5.118	5,5	0.216	1	0.039	2	0.079
130	240	5.118	9.449	7	0.276	1	0.039	2	0.079
240	500	9.449	19.685	11	0.433	2	0.079	3	0.118
500		19.685		13	0.512	5	0.197	5	0.197

¹⁾ If the corner is blended rather than chamfered, the blended section should not be smaller than the difference in diameters $d_1 - d_2$.

Housing bore requirements

General

To reduce the risk of seal damage during installation, the housing bore should have a 15 to 30° lead-in chamfer. The chamfer should be free of burrs and the transition radius r between the seal seat and shoulder should be in accordance with the recommendations in **table 9**.

The depth of a metric housing bore B for metal-cased or metal-inserted seals should be at least 0,3 mm (0.012 in.) larger than the nominal seal width b (→ **fig. 13**). The corresponding values for an inch housing bore B are 0.016 in. (0,4 mm).

Seals without metal reinforcement are manufactured oversized relative to the housing bore diameter and depth to enable proper compression and stability. The actual seal width is approximately 0,4 to 0,8 mm (0.016 to 0.032 in.) wider than the bore depth B . For all-rubber HS seals, the bore depth tolerance should be $\pm 0,13$ mm (0.005 in.) and $\pm 0,10$ mm (0.004 in.) for fabric-reinforced HSF seals.

In order to facilitate seal removal, holes in the housing shoulder A can be incorporated during the design stage. See the illustration in **table 9**.

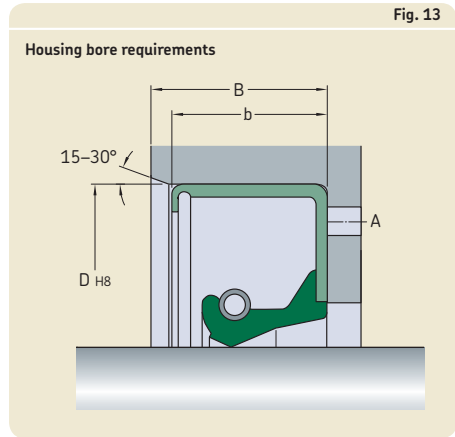

Housing bore tolerances

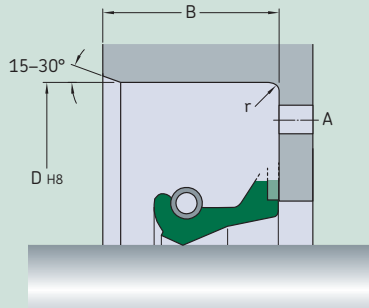

Housing bore for metric seals (ISO)

Nominal diameter D		Housing bore tolerance (ISO tolerance H8)		Fillet radii r max
over	incl.	high	low	
mm		µm		mm
3	3	+14	0	0,3
6	6	+18	0	0,3
	10	+22	0	0,3
10	18	+27	0	0,3
18	30	+33	0	0,3
30	50	+39	0	0,3
50	80	+46	0	0,4
80	120	+54	0	0,8
120	180	+63	0	0,8
180	250	+72	0	0,8
250	315	+81	0	0,8
315	400	+89	0	0,8
400	500	+97	0	0,8
500	630	+110	0	0,8
630	800	+125	0	0,8
800	1 000	+140	0	0,8
1 000	1 250	+165	0	0,8
1 250	1 600	+195	0	0,8
1 600	2 000	+230	0	0,8
2 000	2 500	+280	0	0,8
2 500	3 150	+330	0	0,8
3 150 ¹⁾	4 000	+410	0	0,8
4 000 ¹⁾	5 000	+500	0	0,8

Housing bore for inch-size seals (RMA)

Nominal diameter D		Housing bore tolerance		Fillet radii r max
over	incl.	high	low	
in.		in.		in.
3.000	3.000	+0.001	-0.001	0.031
7.000	7.000	+0.0015	-0.0015	0.031
	10.000	+0.002	-0.002	0.031
10.000 ²⁾	12.000	+0.002	-0.002	0.031
12.000 ²⁾	20.000	+0.003	-0.003	0.031
20.000 ²⁾	40.000	+0.004	-0.004	0.031
40.000 ²⁾	60.000	+0.006	-0.006	0.031

¹⁾ SKF recommended bore specifications not covered in ISO 286-2

²⁾ SKF recommended bore specifications not covered in RMA DS-4

Radial shaft seals

Tolerances

The housing bore diameter D should be machined to tolerance H8 (→ **table 9** on **page 75**). Depending on the operating conditions, out-of-roundness should be 1 to 2 tolerance grades better than H8.

Surface roughness

The surface roughness (to ISO 4288 or DIN 4768) of the housing bore should be kept within the limits specified in **table 10**.

Table 10

Recommended housing bore surface roughness values

	ISO ¹⁾		DIN		RMA ²⁾³⁾	
	μm	μin.	μm	μin.	μm	μin.
R _a	1,6–3,2	64–128	1,6–3,2	64–128	1–2,5	40–100
R _z	6,3–12,5	252–500	10–20	400–800	N/A	N/A
R _{max}	N/A	N/A	25	1 000	N/A	N/A

¹⁾ ISO – The housing bore surface roughness may require lower values when metal-cased seals are used, in which case they should be subject to agreement between the manufacturer and user.

²⁾ RMA – If the bore surface texture is greater than 2,5 μm (100 μin.) R_a, a sealant should be used.

³⁾ RMA – Turned bores, where a lubricant head of up to 0,20 bar (3.0 psi) is present at the seal. If this texture is maintained and tool removal marks or bore defects are present, no outside diameter leakage should occur.

Seal installation, general industrial applications

General

To provide effective sealing, radial shaft seals must be installed properly. An experienced installer with suitable tools, working in a clean environment, is recommended to provide proper installation. The shaft counterface surface and housing bore should meet the demands specified under *Shaft requirements* and *Housing bore requirements* on **pages 70 to 76**.

To facilitate seal installation and to achieve initial lubrication, prior to installation, SKF recommends wiping the shaft and seal with the lubricant that is going to be retained. While the outside diameter of metal-cased seals can be lightly lubricated to ease installation, the outside diameter of rubber covered seals should always be lubricated.

Seals with an auxiliary, contacting lip can also be filled with grease between the sealing lip and auxiliary lip to reduce frictional moment. This does not apply to silicone rubber seals and seals with hydrodynamic features, other than SKF WAVE lip designs.

SKF also recommends using a hydraulic press, with suitable tools, to install a seal in its housing bore. Pressure should be applied as close as possible to the outside diameter of the seal.

Seals that are designed to sit flush with the wall of the housing bore must be installed perpendicular to the housing bore axis. The outside diameter of the tool should be larger than the housing bore diameter (→ **fig. 14**).

When pressing seals up against a shoulder or retaining ring, it is advisable to use tools of the type shown in **figs. 15 and 16**. The necessary ring dimensions can be supplied on request.

Fig. 14

Preferred installation method

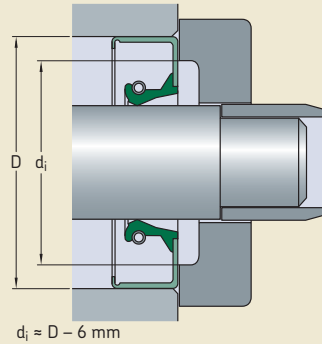

Fig. 15

Alternative installation method

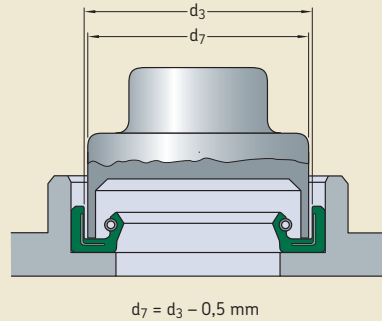
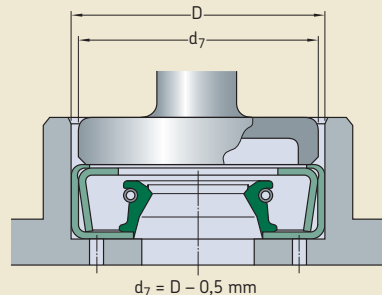

Fig. 16

Alternative installation method



Radial shaft seals

Fig. 17

Installation sleeve

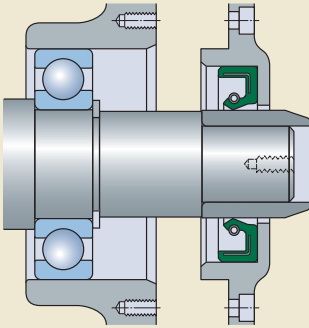

When installing seals on stepped shafts, where the shoulders do not have the recommended chamfer or rounded transition, an installation sleeve as shown in **fig. 17** must be used. If the sealing lip has to pass over grooves, threads or gearing, thin-walled installation sleeves, like those shown in **fig. 18**, can be used to prevent the lip from being damaged. The outside surface of the sleeve should be coated with the same lubricant that is used to lubricate the seal and counterface surface.

Radial shaft seals made of silicone rubber should always be installed using an installation sleeve.

The tools used to install a seal at a certain distance in a cylindrical opening in a housing are shown in **figs. 19** and **20**. Instructions for designing the tools can be supplied on request.

Fig. 18

Thin-walled installation sleeve

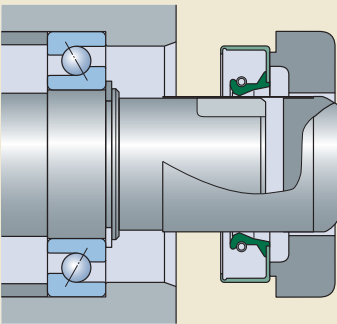
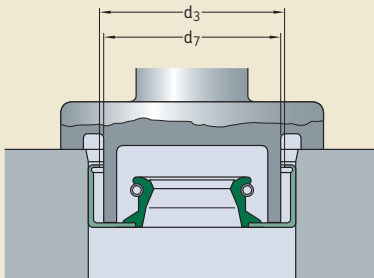

Fig. 19

Installation in a cylindrical opening



$$d_7 = d_3 - 0,5 \text{ mm}$$

Fig. 20

Installation in a cylindrical opening

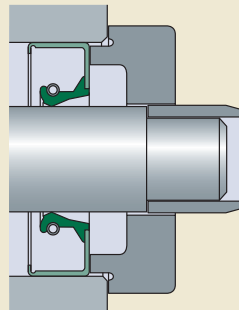

Seal installation, heavy industrial applications

Metal-reinforced seals

When installing metal-reinforced seals, the first step is to check the shaft and housing bore for proper specifications and condition. Next, coat both the seal and bore lightly with a lubricant, preferably the same one that will be used to lubricate the application. For large diameter seals, a special installation tool may not be practical. In these cases, do not hit the seal or seal case directly. Instead, use a wooden block, long enough to span the seal's outside diameter. When using this method, it is important to apply hammer-blows evenly and sequentially to the wood piece around the seal circumference to prevent the seal from tilting or skewing. SKF also recommends the use of a dead blow hammer for full energy transfer with less impact (→ **fig. 21**).

In some applications, the housing is designed for two seals in tandem, or a seal might have to be recessed further into the bore depth. In those cases, first set the seal flush with the housing using the method described above. Then, use a shorter piece of wood to drive the seal deeper into the bore utilizing a sequential pattern (→ **fig. 22**).

Fig. 21

Use a dead blow hammer

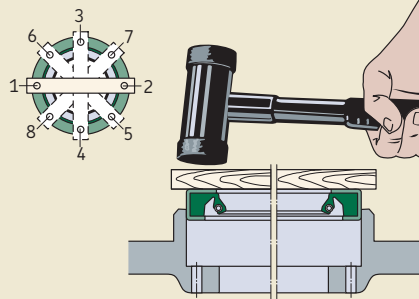

2

Fig. 22

Installation deeper into the bore

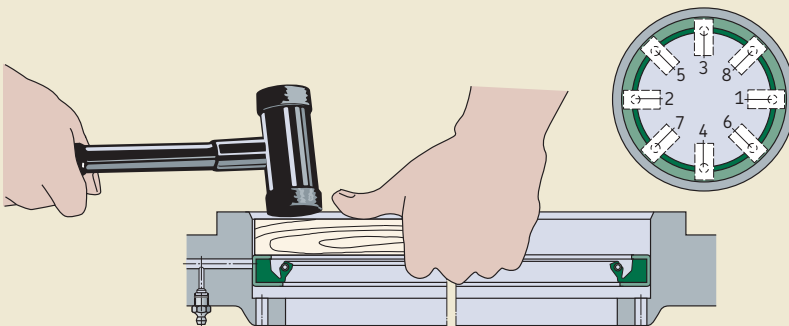

Radial shaft seals

Seals without metal reinforcement

Be sure that the shaft surface and housing bore are clean and that they meet the specifications listed in *Shaft requirements* and *Housing bore requirements* on **pages 70 to 76**. Special care must be taken to avoid nicks and burrs on the shaft and to make sure that the spring is retained in the spring groove.

HS seals are installed differently depending on whether their main purpose in a specific application is to retain lubricant or to exclude contaminants (→ **fig. 23**).

Split seals

Where appropriate, insert the spring in the SKF Springlock groove and position the spring connection, so that it is displaced with regard to the seal joint (→ **A** in **fig. 24**). This is standard with all HS8 seals. Put the seal in the correct position on the shaft.

Lightly coat both the seal and counterface surface with a lubricant, preferably the same lubricant that will be used to lubricate the application (**B**).

Join the ends of the garter spring by using the spring connector (**C**).

For threaded connectors, back-wind the spring a couple of turns before the ends are

brought together and allowed to thread into each other. When using a hook-and-eye connector, draw the ends of the spring together and insert the hook into the eye, taking care not to over-stretch the spring in the process, as this might impair seal performance. When using a control-wire connector, draw the seal ends together and insert the control wire into the centre of the spring coil.

Position the seal joint on the shaft so that it is at the 12 o'clock position and push both ends of the joint into the housing bore (**D**). Do not push only one joint and then work around the shaft as this will create an excess length, making installation difficult or impossible.

Continue at the 3 and 9 o'clock positions, push the rest of the seal into position (**E**) and finish simultaneously at the 6 and 12 o'clock positions. For shaft diameters $\geq 1\,200$ mm (47 in.), it is advisable to fix the seal at the 12, 3, 6 and 9 o'clock positions before locating the remaining sections of the seal.

Use a small block of wood to push the seal in the housing bore until it contacts the housing shoulder (**E**).

Check the seal condition, particularly at the joint, to make sure that it has been positioned properly.

Install the cover plate (see paragraph *Cover plates* on **page 82**) on the housing face. Tighten the bolts evenly until the end cover abuts the housing face (**F** and **G**).

Fig. 23

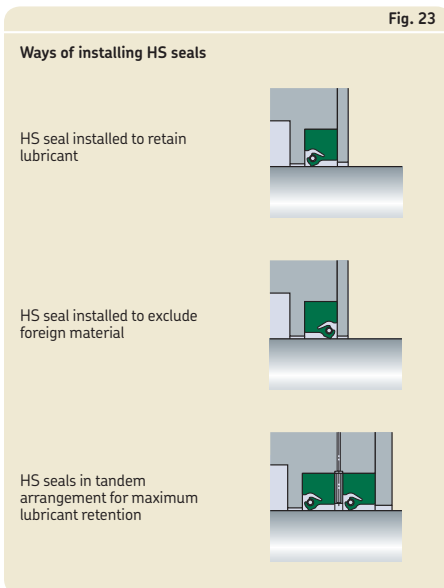

Installing a split seal

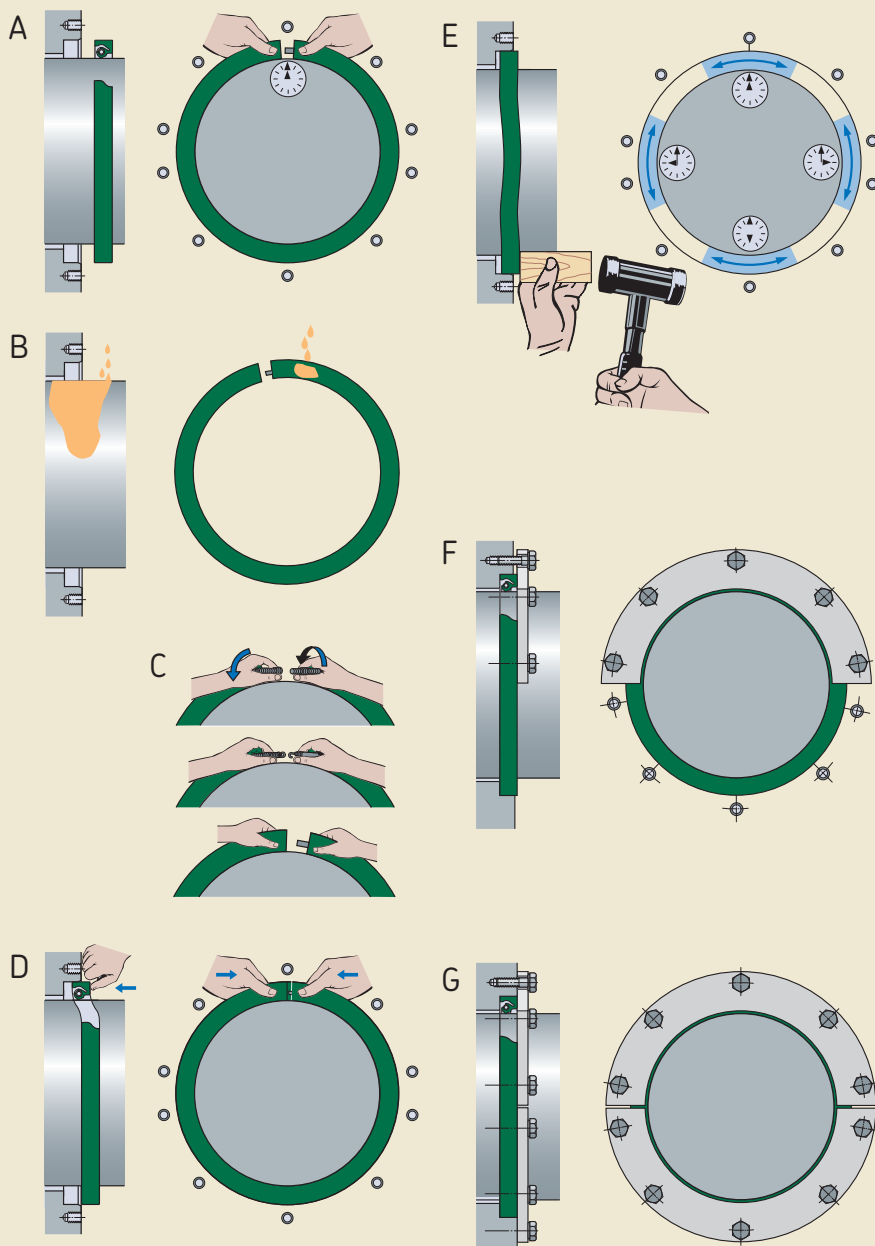

Radial shaft seals

Cover plates

All HS and HSF seals, split and solid, are manufactured oversized relative to the housing bore diameter and depth to enable proper compression and stability. A cover plate (→ **fig. 25**) provides axial compression of the seal and stabilizes it in the housing bore to achieve maximum seal performance. The cover plate must be dimensioned properly to obtain the required fit. It should be thick enough not to bend or distort. Generally, a thickness of 6,35 to 12,7 mm (0.25 to 0.50 in.) is sufficient.

The plate should be fastened with bolts, no more than 150 mm (6 in.) apart, on a bolt circle located as close to the seal housing bore as practical. The cover plate should be flat and the housing bore depth uniform. Splitting the cover plate at 180° will make seal replacement easier, particularly in confined areas.

To block surges of lubricant toward the seal from the inside and to protect the seal from damage from the outside, SKF recommends dimensioning the inside diameter of the cover plate so that it is approximately 6,35 mm (0.25 in.) greater than the shaft diameter to accommodate shaft-to-bore misalignment and runout.

In applications where supplementary sealing is necessary, and it is impractical to machine the original housing to provide a seal cavity, a seal cavity can be incorporated into a new plate that is bolted into place as illustrated in **fig. 26**.

Fig. 25

Cover plate recommendations

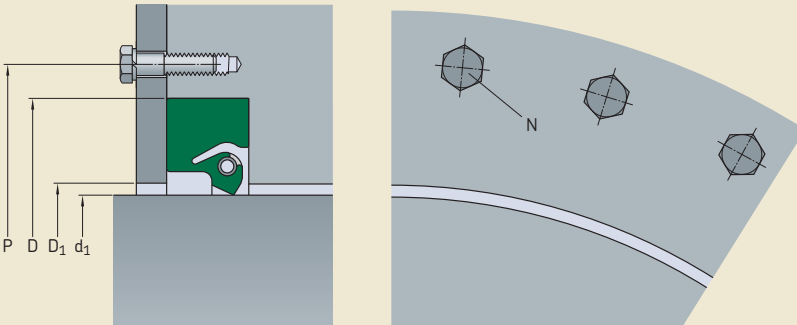

Inside diameter of cover: $D_1 = d_1 + 6 \dots 8$ [mm]
Pitch circle diameter of screws: $P = 1,1 D$ [mm]
No. of attachment screws: $N = 0,02 P$

Fig. 26

Cover plate

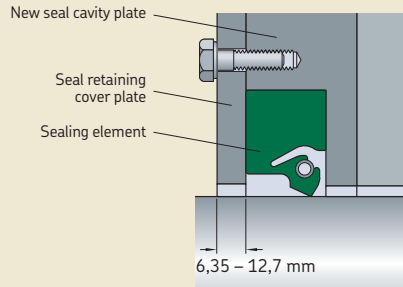

Fig. 27

Spacing washer

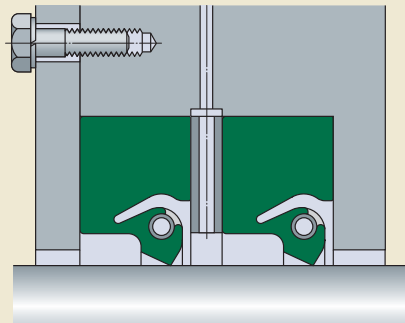
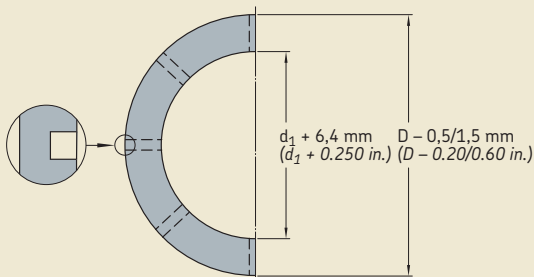

Fig. 28

Details of spacing washer for central lubrication

A separator between two seals can be a slotted washer to promote distribution of the lubricant.



Multiple HS seal installations

When installing two split all-rubber HS seals in one cavity, the locations of the split joints should be staggered by 30° to 60° to minimize the risk of leakage through the joints. The splits should be located toward the top of the bore. Grease the cavity between the seals to provide lubricant to the outer sealing lip.

When two HS seals, split or solid, are installed in the same housing bore, a spacing washer must be placed between the two seals (\rightarrow fig. 27). Suitable washer dimensions can be determined based on the shaft and housing bore diameters, d_1 and D , respectively:

washer inside diameter
 $= d_1 + 6 \text{ to } 10 \text{ mm } (0.25 \text{ to } 0.4 \text{ in.})$

washer outside diameter
 $= D - 0,5 \text{ to } 1,5 \text{ mm } (0.02 \text{ to } 0.06 \text{ in.})$

The width of the washer is determined by the application conditions. There should, however, always be sufficient room for lubrication holes to be provided in the circumference, or lubrication grooves in one side face (\rightarrow fig. 28). These lubrication provisions must enable grease to be supplied from the housing to the sealing lips via a drilled passage or grease fitting (\rightarrow fig. 29 on page 84). When determining what washer width is appropriate for the depth of a housing bore, it is necessary to consider the axial displacement required when clamping the seals.

Radial shaft seals

Multiple HDS seal installations

When installing two metal-cased radial shaft seals in the same housing bore, either in a tandem or back-to-back arrangement, care must be taken that neither of the sealing lips can run dry at any time. To reduce the risk of dry running, the space between the seals should be filled with a suitable grease.

To avoid dry running, SKF recommends using spacer lugs or a spacing washer between the two seals. The spacing washer should be provided with lubrication holes so that grease can be supplied to the space between the sealing lips via a grease fitting (→ **fig. 29**). No spacing washer is required when using seals that have spacer lugs built into the air side of the metal case (→ **fig. 30**). HDS and HDSE seals can be supplied from SKF with holes pre-drilled in the metal case to mate with corresponding passages in the housing bore.

Fig. 29

Spacing washer and grease fitting

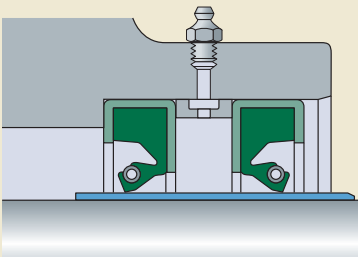
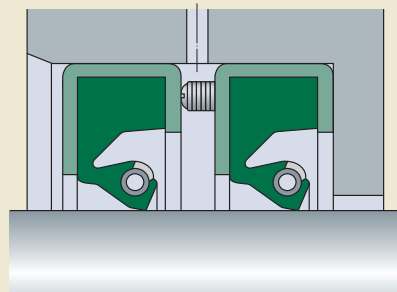

Fig. 30

Spacer lug



PTFE seals

In most cases, small diameter PTFE seals are shipped on a tube that maintains a nominal seal inside diameter (smaller than shaft diameter) during storage. Therefore, they should not be removed from the shipping tube until immediately prior to installation. Also, if quality inspections must be done, SKF recommends that the shipping tube remains in place. The seal inside diameter cannot be accurately measured anyway after manufacturing as the PTFE lip configuration changes over time as it relaxes.

PTFE formulations used for radial lip seals are generally more aggressive and abrasive to the shaft than standard elastomeric materials. Therefore, PTFE sealing lips require a surface hardness value of 58 to 62 HRC. An alternative to a hardened shaft surface is the use of an SKF wear sleeve, manufactured to the same high standards such as the inner rings of SKF needle roller bearings, offering an excellent sealing surface.

In applications where PTFE seals will be retaining a lubricant or be fully flooded with a fluid, the seals should be installed dry. In applications that run dry or will be starved for lubrication, the sealing lip should be pre-lubricated with a grease appropriate for the temperature conditions of the application.

WARNING: At temperatures above 300 °C (570 °F), all PTFE compounds give off dangerous fumes. For additional information, refer to **page 32**.

Radial shaft seals

Installation procedure

PTFE lips do not have the same elastic properties as rubber lips, which makes them more susceptible to damage. Therefore, special care must be taken during installation and handling to prevent damage and help ensure proper operation and function. Shaft features such as keyways and splines, as well as drill holes, ports and sharp-edged shaft steps have the potential to damage PTFE lips. Whenever possible, these obstructions can be covered by using thin-walled installation tools made from plastic or metal.

PTFE lip orientation during installation will determine the installation method. Installation is more difficult when the shaft is installed against the PTFE lip (→ **fig. 31, a and c**). This type of installation becomes even more complicated when the hardware is difficult to access or visually obstructed and may not be possible if an installation tool cannot be used. In any case, when the shaft is installed against the PTFE lip, SKF recommends the use of an installation cone or “bullet”. SKF can quote and manufacture

installation cones if detailed drawings of the shaft and sealing areas are provided. In lieu of installation cones, longer than normal lead-in chamfers on the shaft would be required. However, shaft features that could damage the seal (keyways, etc.) must still be covered, possibly with tape.

If the shaft is installed with the PTFE lip, a smooth, burr-free radius or chamfer on the shaft end is all that is required, provided that no damaging shaft features are present as noted above (→ **fig. 31, b and d**).

Some seals have two PTFE lips facing opposite directions. In this case, installation is always against one of the lips and an installation cone is recommended.

Fig. 31

Seals with a PTFE sealing lip

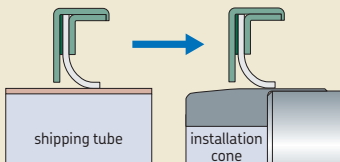

a) Installation against the PTFE lip

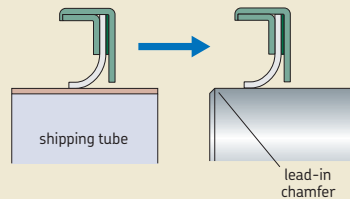

b) Installation with the PTFE lip

Seals with an elastomeric sealing lip and a PTFE auxiliary lip

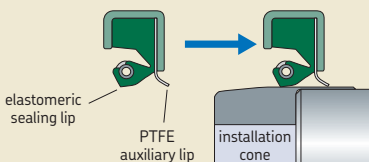

c) Installation against the PTFE lip

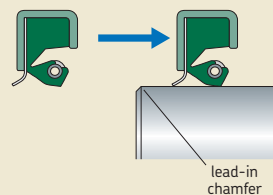

d) Installation with the PTFE lip

Protecting the counterface surface against corrosion

The seal counterface surface should be protected from corrosion until the machine is operational. Be sure to use a rust inhibitor that will last for a year, whether or not the shaft is exposed.

The protective coating should be soluble in the medium to be retained and must not cause any chemical separation as this can impair the sealing performance.

When machines are transported, stored under unfavourable conditions, or out of service for extended periods, special rust inhibitors should be used. These rust inhibitors should form a tough, pliable waxy film that can be removed using neutral solvents that leave an oily residue.

Removal

Because radial shaft seals should never be re-used, there is no need to worry about damaging the seal when removing it. However, prior to removal, it is advisable to note the direction in which the seal is installed so that the replacement seal can be installed in the same direction. Small seals can generally be removed using a screwdriver. The removal of large-size seals is made easier if holes have been provided in the housing shoulder (A), see picture in **table 9**, **page 75**, allowing access for a drift.

Replacement

The lip of the replacement seal should not run on the same path as the lip of the old seal. There are several ways to achieve this:

- Rework or replace the counterface (this may entail removing the shaft).
- Install a wear sleeve.
- Install a spacing ring in the housing bore between the housing shoulder and the seal (→ **fig. 32**).
- Press the new seal to a different depth in a cylindrical opening in the housing, i.e. toward the medium to be sealed.

When choosing a replacement seal, be sure that its design and material correspond to the original seal. In case of doubt, select a seal that meets the operating conditions of the application, and that the seal materials are compatible with the lubricant.

Seals made from a different material should only be used when absolutely necessary. In these cases, the recommendations provided in **table 11** should be followed. The order in which the materials are listed is an indication of their suitability.

If a seal of the same design is not available in the same width as the original, then a somewhat narrower seal can be used, or if the depth of the housing bore allows, a somewhat wider seal can be selected as the replacement.

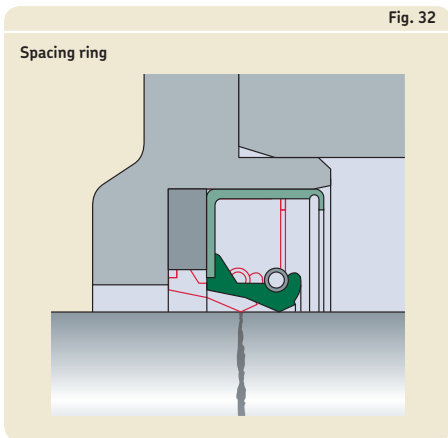

Fig. 32

Table 11

Replacement sealing lip materials

Original	Replacement
Felt	Nitrile rubber Polyacrylate elastomer Fluoro rubber
Leather	Nitrile rubber Fluoro rubber
Nitrile rubber	Polyacrylate elastomer Fluoro rubber Silicone rubber
Polyacrylate elastomer	Fluoro rubber Silicone rubber
Silicone rubber	Fluoro rubber

Designation system

Metric radial shaft seals

Designations of all SKF metric radial shaft seals are prefixed by the letters CR, followed by the shaft diameter, housing bore diameter and nominal seal width (bore depth for HSF and HS seals) in millimetres, design and the code of the sealing lip material (→ **table 12**).

Inch-size radial shaft seals

Inch-size SKF radial shaft seals are identified by their stock number that consists of four to seven digits, prefixed by the letters CR. The stock number provides an indication of seal size.

Four-figure numbers are used for radial shaft seals for

shaft diameters: $d_1 \leq 1$ in., e.g.
CR 3680 $d_1 = 0.375$ in.

Five-figure numbers are used for radial shaft seals for

shaft diameters: $d_1 \leq 10$ in., e.g.
CR 41287 $d_1 = 4.125$ in.
CR 97545 $d_1 = 9.750$ in.

Six- and seven-figure numbers are used for radial shaft seals for

shaft diameters: $d_1 \geq 10$ in., e.g.
CR 120061 $d_1 = 12$ in.
CR 1375242 $d_1 = 13.75$ in.

Assortment and availability

The SKF assortment of radial shaft seals comprises some 200 designs and executions for applications within basically all industries. The radial shaft seals described in this publication belong to the standard range and most of them are available in both metric and inch sizes. New seal designs and sizes are continually added. For additional information, contact SKF.

Designation system for metric radial shaft seals

	CR	55 × 72 × 8	HMSA10	RG	1
Prefix CR					
Dimensions 55 72 8		Shaft diameter Housing bore diameter Nominal seal width (bore depth for HSF and HS seals)			
Design HMSA10					
Lip material RG				Acrylonitrile-butadiene rubber, SKF developed, used for the HMS5 and HMSA10 seals	
Execution 1, 2 ...					Seals of the same size and design that differ in execution from the basic design are identified by a number e.g. R1

Radial shaft seals

Seals for general industrial applications, selected main designs

RG, R Nitrile rubber
 V Fluoro rubber
 T Polytetrafluoroethylene (PTFE)

Seal designs

Design

Outside diameter
 Configuration

Material
 code

Sealing lip
 Configuration

Material
 code

Auxiliary lip
 A = Contacting
 B = Non-contacting

			Rubber	RG, V	Straight	RG V	B (HMSA10)
HMS5	HMSA10						
			Rubber	R, V	Straight	R V	B (HMSA7)
HMS4	HMSA7						
			Metal	N/A	SKF WAVE	R V	N/A
CRW1	CRWH1						
			Metal	N/A	SKF WAVE	R V	B
CRWA1	CRWHA1						
			Metal	N/A	SKF WAVE	R V	A (CRWA5)
CRW5	CRWA5						
			Metal	N/A	Straight	R V	N/A
CRS1	CRSH1						
			Metal	N/A	Straight	R V	A
CRSA1	CRSHA1						
			Metal	N/A	Straight	R V	N/A
HM14							
			Rubber	R	Special	R	N/A
X15							
			Metal	N/A	Special	T	N/A
SL	SLX	SLS					
			Metal	N/A	Special	T	A (SLA, DLA)
SLA	DL	DLA					
			Fluoroplastic/ (rubber)	T (+ R, V)	Special	T	N/A
YSLE	YNSLE	YSL					

* PTFE designs are made to order to handle temperatures, pressures and speeds that may exceed those stated for rubber sealing lip designs.

Operating temperature range				Shaft-to-bore misalignment (STBM) TIR		Dynamic runout (DRO) TIR		Pressure differential		Maximum shaft surface speed	
from	to	from	to								
°C		°F		mm	in.	mm	in.	MPa	psi	m/s	ft/min
-40	100	-40	210	0,38	0.015	0,51	0.020	0,03	5	14,00	2 755
-40	200	-40	390								
-40	100	-40	210	0,38	0.015	0,51	0.020	0,03	5	14,00	2 755
-40	200	-40	390								
-40	100	-40	210	0,38	0.015	0,51	0.020	0,07	10	18	3 600
-40	200	-40	390								
-40	100	-40	210	0,38	0.015	0,51	0.020	0,07	10	18	3 600
-40	200	-40	390								
-40	100	-40	210	0,13	0.005	0,13	0.005	0,35	50	10	2 000
-40	200	-40	390								
-40	100	-40	210	0,38	0.015	0,51	0.020	0,07	10	18	3 600
-40	200	-40	390								
-40	100	-40	210	0,38	0.015	0,51	0.020	0,07	10	18	3 600
-40	200	-40	390								
-40	100	-40	210	0,13	0.005	0,08	0.003	0,07	10	10	2 000
-40	200	-40	390								
-40	100	-40	210	0,38	0.015	0,25	0.010	0,02	3	2,54	500
-70	250	-95	480	*	*	*	*	*	*	*	*
-70	250	-95	480	*	*	*	*	*	*	*	*
-70	250	-95	480	*	*	*	*	*	*	*	*

Seals for general industrial applications

HMS5 and HMSA10 seals

Main features

SKF metric rubber outside diameter radial shaft seals, HMS5 and HMSA10, are designed in accordance with ISO 6194-1 and DIN 3760 for use in a wide range of industrial applications. The available size range of HMS5 and HMSA10 seals includes a full coverage of the ISO 6194-1 and DIN 3760 dimensions for shaft diameters up to 250 mm (9.842 in.) as well as an extensive range of dimensions commonly used in the market. New dimensions are continually added. Main features include:

- optimized sealing lip material
- spring-loaded sealing lip
- optimally balanced sealing lip and flex section
- beaded outside diameter
- auxiliary lip (HMSA10 seals only)

Design

The rubber outside diameter provides optimized sealing ability in the housing, also at considerable surface roughness or in split housings. The beads on the outside diameter provide improved sealing ability and retention in the bore. They also prevent spring-back during installation.

The spring-loaded sealing lip contributes to a quick response in handling dynamic runout and maintaining the sealing performance, even when sealing lip wear is excessive.

Sealing lip and flex section are optimally balanced to withstand both high dynamic runout and shaft-to-bore misalignment.

The auxiliary lip on HMSA10 seals is non-contacting, which means that the seals normally can operate at the same speeds as the single-lip HMS5 seals.



Material

The optimized nitrile rubber compound used for the HMS5 and HMSA10 seals has the designation suffix RG. The compound is the result of long experience and the latest findings from the SKF seal material developments. Advantages of this material include:

- good resistance to ageing
- very good compatibility with synthetic oils
- very good pumping ability
- good wear resistance

Pumping ability is defined as the time it takes for the seal to return a certain amount of oil from the air side to the oil side. The microstructure of SKF's RG nitrile rubber compound promotes rapid pumping of the oil, (→ **table 13**). In **diagram 8**, results from endurance tests show the extended service life of seals made of the optimized nitrile compound.

The complete range of HMS5 and HMSA10 seals is also available in a fluoro rubber compound with a stainless steel garter spring. This rubber compound has the designation suffix V and is used in applications where temperatures exceed the limits of nitrile rubber.

Applications and operating conditions

HMS5 and HMSA10 seals are designed for oil or grease lubricated applications with operating temperatures ranging from -40 to $+100$ °C (-40 to $+210$ °F), short-term up to 120 °C (250 °F). These seals are also appropriate for sealing lubricants within a wide range of viscosities.

Circumferential speed: up to 14 m/s
($2\,755$ ft/min)

Operating pressure: max $0,03$ MPa (5 psi)

These values are the maximum value for each service condition and should not occur together. Consideration should be given as to how the operating conditions affect each other.

Table 13

Speed Rotating	Circum- ferential	Pumping time	
		Standard NBR	SKF compound RG
r/min	m/s	s	
1 000	3,1	–	117
1 500	4,7	280	69
2 000	6,3	186	50
2 500	7,9	130	40
3 000	9,4	102	31
3 500	11,0	82	25
4 000	12,6	68	21
4 500	14,1	57	18

Shaft diameter 60 mm, engine oil SAE 30

2

Diagram 8

Average seal life
(as a percentage of baseline, product A)

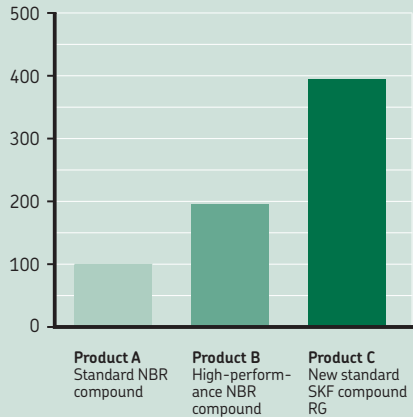

Radial shaft seals – HMS5 and HMSA10

d_1 6 – 30 mm

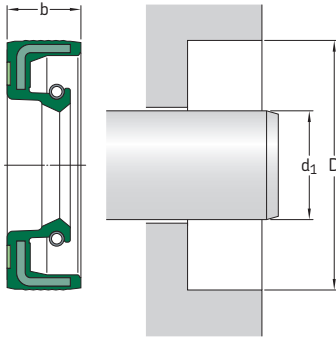

¹⁾ Designation to be followed by the design and material codes, indicating one of the four variants available for each dimension:

HMS5 RG without auxiliary lip, nitrile rubber
HMS5 V without auxiliary lip, fluoro rubber
HMSA10 RG with auxiliary lip, nitrile rubber
HMSA10 V with auxiliary lip, fluoro rubber
 Example: **CR 6x16x5 HMSA10 RG**

²⁾ Design execution differs from the basic design and is indicated by a number, see also **page 89**.

Please see **pages 74 to 76** for housing bore requirements.

Dimensions			Designation ¹⁾	ISO/DIN
Shaft	Bore	Nominal seal width		
d_1	D	b		
mm			–	–
6	16	5	CR 6x16x5	•
	16	7	CR 6x16x7	•
	22	7	CR 6x22x7	•
7	16	7	CR 7x16x7 ²⁾	•
	22	7	CR 7x22x7	•
8	18	5	CR 8x18x5	•
	18	7	CR 8x18x7	•
	22	7	CR 8x22x7	•
	24	7	CR 8x24x7	•
9	22	7	CR 9x22x7	•
10	19	7	CR 10x19x7 ²⁾	•
	20	6	CR 10x20x6	•
	20	7	CR 10x20x7	•
	22	7	CR 10x22x7	•
12	24	7	CR 10x24x7	•
	25	7	CR 10x25x7	•
	26	7	CR 10x26x7	•
	19	5	CR 12x19x5 ²⁾	•
	22	5	CR 12x22x5	•
	22	6	CR 12x22x6	•
13	22	7	CR 12x22x7	•
	24	7	CR 12x24x7	•
	25	7	CR 12x25x7	•
	28	7	CR 12x28x7	•
	30	7	CR 12x30x7	•
	32	7	CR 12x32x7	•
	26	7	CR 13x26x7	•
14	24	7	CR 14x24x7	•
	25	5	CR 14x25x5	•
	28	7	CR 14x28x7	•
	30	7	CR 14x30x7	•

Dimensions			Designation ¹⁾	ISO/DIN
Shaft	Bore	Nominal seal width		
d_1	D	b		
mm			–	–
15	24	7	CR 15x24x7 ²⁾	•
	25	5	CR 15x25x5	•
	25	6	CR 15x25x6	•
	26	7	CR 15x26x7	•
	30	7	CR 15x30x7	•
	32	7	CR 15x32x7	•
	35	7	CR 15x35x7	•
	40	10	CR 15x40x10	•
16	24	7	CR 16x24x7 ²⁾	•
	28	7	CR 16x28x7	•
	30	7	CR 16x30x7	•
	32	7	CR 16x32x7	•
	35	7	CR 16x35x7	•
17	28	7	CR 17x28x7	•
	29	5	CR 17x29x5	•
	30	7	CR 17x30x7	•
	32	7	CR 17x32x7	•
	35	7	CR 17x35x7	•
	40	7	CR 17x40x7	•
	40	10	CR 17x40x10	•
18	28	7	CR 18x28x7	•
	30	6	CR 18x30x6	•
	30	7	CR 18x30x7	•
	32	7	CR 18x32x7	•
	35	7	CR 18x35x7	•
	40	7	CR 18x40x7	•
19	30	7	CR 19x30x7	•
	30	8	CR 19x30x8	•
	32	7	CR 19x32x7	•
	42	6	CR 19x42x6	•

Dimensions			Designation ¹⁾	ISO/DIN	Dimensions			Designation ¹⁾	ISO/DIN		
Shaft	Bore	Nominal seal width			Shaft	Bore	Nominal seal width				
d ₁	D	b				b					
mm			–	–	mm		–	–			
20	30	5	CR 20×30×5		25	46	7	CR 25×46×7			
	30	7	CR 20×30×7	•		cont.	47	7	CR 25×47×7	•	
	32	6	CR 20×32×6				47	10	CR 25×47×10		
	32	7	CR 20×32×7								
	34	7	CR 20×34×7				50	10	CR 25×50×10		
							52	7	CR 25×52×7	•	
	35	6	CR 20×35×6				52	8	CR 25×52×8		
	35	7	CR 20×35×7	•			52	10	CR 25×52×10		
	35	8	CR 20×35×8								
	35	10	CR 20×35×10				62	7	CR 25×62×7		
							62	8	CR 25×62×8		
	36	7	CR 20×36×7				62	10	CR 25×62×10		
	38	7	CR 20×38×7				72	7	CR 25×72×7		
	40	7	CR 20×40×7	•		26	37	7	CR 26×37×7		
	40	10	CR 20×40×10					38	5	CR 26×38×5	
	42	7	CR 20×42×7					38	7	CR 26×38×7	
	42	10	CR 20×42×10								
47	7	CR 20×47×7			42		7	CR 26×42×7			
47	10	CR 20×47×10			47		7	CR 26×47×7			
	52	7	CR 20×52×7		27	37	7	CR 27×37×7			
	52	10	CR 20×52×10				42	10	CR 27×42×10		
							43	7	CR 27×43×7		
							47	10	CR 27×47×10		
21	35	7	CR 21×35×7		28	38	7	CR 28×38×7			
	40	7	CR 21×40×7				38	8	CR 28×38×8		
22	32	7	CR 22×32×7			40	7	CR 28×40×7	•		
	35	7	CR 22×35×7	•		40	8	CR 28×40×8			
	36	7	CR 22×36×7			42	7	CR 28×42×7			
	38	8	CR 22×38×8			42	8	CR 28×42×8			
	40	7	CR 22×40×7	•		44	6	CR 28×44×6			
	40	10	CR 22×40×10			45	8	CR 28×45×8			
	42	10	CR 22×42×10			47	7	CR 28×47×7	•		
	47	7	CR 22×47×7	•		47	10	CR 28×47×10			
23	40	10	CR 23×40×10			52	7	CR 28×52×7	•		
						52	10	CR 28×52×10			
24	35	7	CR 24×35×7		30	40	7	CR 30×40×7	•		
	37	7	CR 24×37×7				42	6	CR 30×42×6		
							42	7	CR 30×42×7	•	
						42	8	CR 30×42×8			
25	35	6	CR 25×35×6			44	7	CR 30×44×7			
	35	7	CR 25×35×7	•		45	7	CR 30×45×7			
						45	8	CR 30×45×8			
	37	5	CR 25×37×5			46	7	CR 30×46×7			
	37	6	CR 25×37×6								
	37	7	CR 25×37×7			47	6	CR 30×47×6			
	38	7	CR 25×38×7			47	7	CR 30×47×7	•		
						47	8	CR 30×47×8			
	40	5	CR 25×40×5			47	10	CR 30×47×10			
	40	7	CR 25×40×7	•		48	8	CR 30×48×8			
	40	8	CR 25×40×8								
	40	10	CR 25×40×10			50	7	CR 30×50×7			
						50	8	CR 30×50×8			
	42	6	CR 25×42×6			50	10	CR 30×50×10			
	42	7	CR 25×42×7								
42	10	CR 25×42×10			52	7	CR 30×52×7	•			
45	7	CR 25×45×7			52	8	CR 30×52×8				
45	8	CR 25×45×8			52	10	CR 30×52×10				
45	10	CR 25×45×10									
					55	7	CR 30×55×7				
					55	10	CR 30×55×10				



Radial shaft seals – HMS5 and HMSA10

d_1 30 – 52 mm

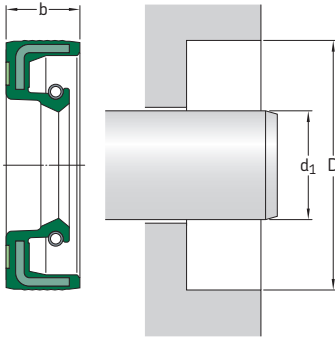

¹⁾ Designation to be followed by the design and material codes, indicating one of the four variants available for each dimension:

HMS5 RG without auxiliary lip, nitrile rubber
HMS5 V without auxiliary lip, fluoro rubber
HMSA10 RG with auxiliary lip, nitrile rubber
HMSA10 V with auxiliary lip, fluoro rubber
 Example: **CR 6x16x5 HMSA10 RG**

Please see **pages 74 to 76** for housing bore requirements.

Dimensions			Designation ¹⁾	ISO/DIN
Shaft	Bore	Nominal seal width		
d_1	D	b		
mm			–	–
30	62	7	CR 30x62x7	
cont.	62	10	CR 30x62x10	
	72	10	CR 30x72x10	
32	42	7	CR 32x42x7	
	43	7	CR 32x43x7	
	44	7	CR 32x44x7	
	45	7	CR 32x45x7	•
	45	8	CR 32x45x8	•
	47	6	CR 32x47x6	
	47	7	CR 32x47x7	•
	47	8	CR 32x47x8	•
	47	10	CR 32x47x10	
	48	8	CR 32x48x8	
	50	8	CR 32x50x8	
	50	10	CR 32x50x10	
	52	7	CR 32x52x7	•
	52	8	CR 32x52x8	•
	55	10	CR 32x55x10	
	62	10	CR 32x62x10	
	72	7	CR 32x72x7	
33	45	7	CR 33x45x7	
	50	6	CR 33x50x6	
34	44	8	CR 34x44x8	
	48	8	CR 34x48x8	
	52	8	CR 34x52x8	
	62	10	CR 34x62x10	
35	45	7	CR 35x45x7	
	47	6	CR 35x47x6	
	47	7	CR 35x47x7	•
	47	8	CR 35x47x8	•
	48	8	CR 35x48x8	
	49	6	CR 35x49x6	

Dimensions			Designation ¹⁾	ISO/DIN
Shaft	Bore	Nominal seal width		
d_1	D	b		
mm			–	–
35	50	7	CR 35x50x7	•
cont.	50	8	CR 35x50x8	•
	50	10	CR 35x50x10	
	52	7	CR 35x52x7	•
	52	8	CR 35x52x8	•
	52	10	CR 35x52x10	
	55	7	CR 35x55x7	•
	55	8	CR 35x55x8	•
	55	10	CR 35x55x10	
	56	10	CR 35x56x10	
	58	10	CR 35x58x10	
	60	10	CR 35x60x10	
	62	7	CR 35x62x7	
	62	8	CR 35x62x8	
	62	10	CR 35x62x10	
	72	10	CR 35x72x10	
	72	12	CR 35x72x12	
	80	12	CR 35x80x12	
36	47	7	CR 36x47x7	
	50	7	CR 36x50x7	
	52	7	CR 36x52x7	
	58	10	CR 36x58x10	
	62	7	CR 36x62x7	
37	50	6	CR 37x50x6	
38	50	7	CR 38x50x7	
	52	7	CR 38x52x7	
	52	8	CR 38x52x8	
	54	10	CR 38x54x10	
	55	7	CR 38x55x7	•
	55	8	CR 38x55x8	•
	55	10	CR 38x55x10	

Dimensions			Designation ¹⁾	ISO/DIN	Dimensions			Designation ¹⁾	ISO/DIN	
Shaft	Bore	Nominal seal width			Shaft	Bore	Nominal seal width			
d ₁	D	b								
mm			–	–	mm		–	–		
38 cont.	58	8	CR 38×58×8	•	45	55	7	CR 45×55×7		
	58	10	CR 38×58×10			58	7	CR 45×58×7		
	60	10	CR 38×60×10				60	7	CR 45×60×7	
	62	7	CR 38×62×7	•			60	8	CR 45×60×8	•
	62	8	CR 38×62×8	•			60	10	CR 45×60×10	
	62	10	CR 38×62×10				62	7	CR 45×62×7	
38,5	72	10	CR 38×72×10			62	8	CR 45×62×8	•	
	72	10	CR 38×72×10			62	10	CR 45×62×10		
40	58	7	CR 38,5×58×7			65	8	CR 45×65×8	•	
	50	8	CR 40×50×8			65	10	CR 45×65×10		
	52	6	CR 40×52×6			68	7	CR 45×68×7		
	52	7	CR 40×52×7	•		68	10	CR 45×68×10		
	52	8	CR 40×52×8	•		68	12	CR 45×68×12		
		55	7	CR 40×55×7	•		72	8	CR 45×72×8	
		55	8	CR 40×55×8	•		72	10	CR 45×72×10	
		56	8	CR 40×56×8			75	8	CR 45×75×8	
		58	7	CR 40×58×7			75	10	CR 45×75×10	
		58	8	CR 40×58×8			80	10	CR 45×80×10	
		58	10	CR 40×58×10			85	10	CR 45×85×10	
		60	8	CR 40×60×8			100	10	CR 45×100×10	
	60	10	CR 40×60×10		46	59	12	CR 46×59×12		
	62	6	CR 40×62×6			65	10	CR 46×65×10		
	62	7	CR 40×62×7	•	47	65	10	CR 47×65×10		
	62	8	CR 40×62×8	•		70	10	CR 47×70×10		
	62	10	CR 40×62×10		48	62	8	CR 48×62×8	•	
	65	10	CR 40×65×10			65	10	CR 48×65×10		
	65	12	CR 40×65×12			68	10	CR 48×68×10		
	68	8	CR 40×68×8			70	10	CR 48×70×10		
	68	10	CR 40×68×10			72	7	CR 48×72×7		
	70	8	CR 40×70×8			72	8	CR 48×72×8		
	72	7	CR 40×72×7			72	10	CR 48×72×10		
	72	10	CR 40×72×10		50	62	7	CR 50×62×7		
	80	10	CR 40×80×10			64	6	CR 50×64×6		
	80	12	CR 40×80×12			65	8	CR 50×65×8	•	
	90	10	CR 40×90×10		65	10	CR 50×65×10			
41	56	7	CR 41×56×7			68	7	CR 50×68×7		
						68	8	CR 50×68×8	•	
42	55	7	CR 42×55×7			68	10	CR 50×68×10		
	55	8	CR 42×55×8	•		70	10	CR 50×70×10		
	56	7	CR 42×56×7			72	8	CR 50×72×8	•	
	60	7	CR 42×60×7			72	10	CR 50×72×10		
	62	7	CR 42×62×7			72	12	CR 50×72×12		
	62	8	CR 42×62×8	•		75	10	CR 50×75×10		
	62	10	CR 42×62×10			80	8	CR 50×80×8		
	65	10	CR 42×65×10			80	10	CR 50×80×10		
	65	12	CR 42×65×12			85	10	CR 50×85×10		
	66	10	CR 42×66×10			90	10	CR 50×90×10		
	67	10	CR 42×67×10		52	63	8	CR 52×63×8		
		72	8	CR 42×72×8			65	8	CR 52×65×8	
	72	10	CR 42×72×10			68	8	CR 52×68×8		
43	62	8	CR 43×62×8			72	8	CR 52×72×8		
						72	10	CR 52×72×10		
44	60	10	CR 44×60×10							
	62	10	CR 44×62×10							
	65	10	CR 44×65×10							

Radial shaft seals – HMS5 and HMSA10

d_1 52 – 250 mm

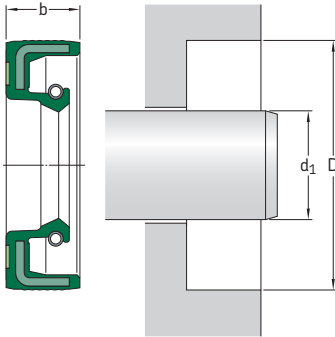

¹⁾ Designation to be followed by the design and material codes, indicating one of the four variants available for each dimension:

HMS5 RG without auxiliary lip, nitrile rubber
HMS5 V without auxiliary lip, fluoro rubber
HMSA10 RG with auxiliary lip, nitrile rubber
HMSA10 V with auxiliary lip, fluoro rubber
 Example: **CR 6x16x5 HMSA10 RG**

Please see **pages 74 to 76** for housing bore requirements.

Dimensions		Nominal seal width b	Designation ¹⁾	ISO/DIN
Shaft d_1	Bore D			
mm				
52	80	10	CR 52x80x10	
cont.	85	10	CR 52x85x10	
55	68	8	CR 55x68x8	
	70	8	CR 55x70x8	•
	70	10	CR 55x70x10	
	72	8	CR 55x72x8	•
	72	10	CR 55x72x10	
	75	10	CR 55x75x10	
	78	10	CR 55x78x10	
	78	12	CR 55x78x12	
	80	8	CR 55x80x8	•
	80	10	CR 55x80x10	
	85	8	CR 55x85x8	
	85	10	CR 55x85x10	
	90	10	CR 55x90x10	
	100	12	CR 55x100x12	
56	72	8	CR 56x72x8	
57	67	7	CR 57x67x7	
58	72	8	CR 58x72x8	
	80	8	CR 58x80x8	
	80	10	CR 58x80x10	
	80	12	CR 58x80x12	
60	72	8	CR 60x72x8	
	75	8	CR 60x75x8	•
	80	8	CR 60x80x8	•
	80	10	CR 60x80x10	
	82	12	CR 60x82x12	
	85	8	CR 60x85x8	•
	85	10	CR 60x85x10	

Dimensions		Nominal seal width b	Designation ¹⁾	ISO/DIN	
Shaft d_1	Bore D				
mm					
60	90	8	CR 60x90x8		
	cont.	90	10	CR 60x90x10	
		95	10	CR 60x95x10	
	100	10	CR 60x100x10		
	110	8	CR 60x110x8		
62	80	10	CR 62x80x10		
	85	10	CR 62x85x10		
	90	10	CR 62x90x10		
63	85	10	CR 63x85x10		
	90	10	CR 63x90x10		
64	80	8	CR 64x80x8		
	65	80	8	CR 65x80x8	
		85	8	CR 65x85x8	
85		10	CR 65x85x10	•	
	85	12	CR 65x85x12		
	88	12	CR 65x88x12		
	90	10	CR 65x90x10	•	
	95	10	CR 65x95x10		
	100	10	CR 65x100x10		
68	90	10	CR 68x90x10		
	70	85	8	CR 70x85x8	
90		10	CR 70x90x10	•	
90		12	CR 70x90x12		
92		12	CR 70x92x12		
95		10	CR 70x95x10	•	
	100	10	CR 70x100x10		
	110	10	CR 70x110x10		
	110	12	CR 70x110x12		
72	90	10	CR 72x90x10		
	95	10	CR 72x95x10		
	100	10	CR 72x100x10		

Dimensions			Designation ¹⁾	ISO/DIN	Dimensions			Designation ¹⁾	ISO/DIN				
Shaft	Bore	Nominal seal width			Shaft	Bore	Nominal seal width						
d ₁	D	b											
mm			–	–	mm		–	–					
75	90	10	CR 75×90×10		140	160	12	CR 140×160×12					
	95	10	CR 75×95×10	•		170	12	CR 140×170×12	•				
	95	12	CR 75×95×12			170	15	CR 140×170×15					
						180	12	CR 140×180×12					
	100	10	CR 75×100×10	•		145	175	15	CR 145×175×15	•			
	100	12	CR 75×100×12				148	170	15	CR 148×170×15			
	105	10	CR 75×105×10					150	180	12	CR 150×180×12		
110	12	CR 75×110×12		180	15				CR 150×180×15	•			
110	12	CR 75×110×12		155	180	15			CR 155×180×15				
120	12	CR 75×120×12			160	185	15		CR 160×185×15				
78	100	10	CR 78×100×10				190	15	CR 160×190×15	•			
	80	95	10			CR 80×95×10	•	165	190	15	CR 165×190×15		
		100	10	CR 80×100×10			170		200	15	CR 170×200×15	•	
		100	12	CR 80×100×12		180			210	15	CR 180×210×15	•	
		105	10	CR 80×105×10	•				190	220	15	CR 190×220×15	•
		110	10	CR 80×110×10	•					225	15	CR 190×225×15	
		110	12	CR 80×110×12						200	230	15	CR 200×230×15
115	12	CR 80×115×12		210	240			15			CR 210×240×15	•	
85	100	10	CR 85×100×10				220	250			15	CR 220×250×15	•
	105	12	CR 85×105×12			230		260			15	CR 230×260×15	•
	110	12	CR 85×110×12		•			240	270		15	CR 240×270×15	•
	115	12	CR 85×115×12						250		280	15	CR 250×280×15
	120	12	CR 85×120×12		•					285	15	CR 250×285×15	
	130	12	CR 85×130×12		100					120	10	CR 100×120×10	
90	110	10	CR 90×110×10				120			12	CR 100×120×12	•	
	110	12	CR 90×110×12	•		125	12			CR 100×125×12	•		
	115	12	CR 90×115×12			105	130	12		CR 100×130×12	•		
	120	12	CR 90×120×12	•			140	12	CR 100×140×12	•			
	95	115	12	CR 95×115×12			•	150	12	CR 100×150×12			
120		12	CR 95×120×12	•	110		130	12	CR 110×130×12	•			
125		12	CR 95×125×12	•			140	12	CR 110×140×12	•			
100		120	10	CR 100×120×10			150	12	CR 110×150×12				
	120	12	CR 100×120×12	•		115	140	12	CR 115×140×12	•			
	125	12	CR 100×125×12	•	150		12	CR 115×150×12					
105	130	12	CR 105×130×12	•	120		140	12	CR 120×140×12				
	140	12	CR 105×140×12			150	12	CR 120×150×12					
	110	130	12	CR 110×130×12		•	160	12	CR 120×160×12				
140		12	CR 110×140×12	•	125	150	12	CR 125×150×12	•				
150		12	CR 110×150×12			130	160	12	CR 130×160×12	•			
115	140	12	CR 115×140×12	•			160	15	CR 130×160×15				
	150	12	CR 115×150×12		135		170	12	CR 135×170×12	•			
	120	140	12	CR 120×140×12									
150		12	CR 120×150×12										
160		12	CR 120×160×12										
125	150	12	CR 125×150×12	•									
	130	160	12	CR 130×160×12	•								
160		15	CR 130×160×15										

Radial shaft seals

CRW1, CRWA1, CRWH1 and CRWHA1 seals

These radial shaft seals are low-friction seals with SKF WAVE lip design for reduced heat generation. See pages 57 and 58 for more information on SKF WAVE lip design. They have a metal outside diameter for easy installation and a firm and accurate fit in the housing bore.

The seals feature SKF Bore Tite Coating on the outside diameter, a non-hardening, water-based acrylic sealant that helps fill small imperfections in the housing bore.

They are primarily designed to retain lubricants but are also suitable for contaminant exclusion, especially the CRWA1 and CRWHA1 seals designed with an auxiliary lip.

CRW1: Seal with a single steel case, SKF WAVE lip and a carbon steel garter spring.

CRWH1: Seal with a double steel case, SKF WAVE lip and a carbon steel garter spring.

CRWA1: Seal with a single steel case, SKF WAVE lip, a carbon steel garter spring and an auxiliary, non-contacting lip.

CRWHA1: Seal with a double steel case, SKF WAVE lip, a carbon steel garter spring and an auxiliary, non-contacting lip.

All of these seals are available with sealing lips made of either nitrile rubber or the SKF developed fluoro rubber compound SKF Duralife. Other materials are also available on request.

See **matrix 1** on **pages 90** and **91** for permissible operating conditions.

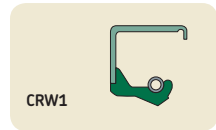

Radial shaft seals – CRW1, CRWA1, CRWH1 and CRWA1 – metric dimensions
 d_1 12 – 17 mm

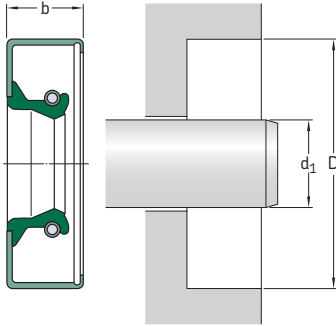

Please see pages 74 to 76 for housing bore requirements.

Dimensions Shaft	Bore	Nominal seal width	Design and lip material	Designation
d_1	D	b		
mm			–	–
12	22	7	CRW1 V	CR 12×22×7 CRW1 V
	22	7	CRW1 R	CR 12×22×7 CRW1 R
	25	7	CRW1 R	CR 12×25×7 CRW1 R
	26	7	CRW1 R	CR 12×26×7 CRW1 R
	28	7	CRW1 R	CR 12×28×7 CRW1 R
	28	7	CRW1 P	CR 12×28×7 CRW1 P
	32	7	CRW1 R	CR 12×32×7 CRW1 R
	32	7	CRW1 V	CR 12×32×7 CRW1 V
	35	7	CRW1 R	CR 12×35×7 CRW1 R
	14	26	7	CRW1 V
32		7	CRW1 R	CR 14×32×7 CRW1 R
15	25	7	CRW1 P	CR 15×25×7 CRW1 P
	28	7	CRW1 R	CR 15×28×7 CRW1 R
	32	7	CRW1 R	CR 15×32×7 CRW1 R
	32	7	CRW1 V	CR 15×32×7 CRW1 V
35	35	7	CRW1 R	CR 15×35×7 CRW1 R
	35	7	CRW1 P	CR 15×35×7 CRW1 P
16	28	7	CRW1 R	CR 16×28×7 CRW1 R
	30	7	CRW1 R	CR 16×30×7 CRW1 R
	32	7	CRW1 R	CR 16×32×7 CRW1 R
	35	7	CRW1 R	CR 16×35×7 CRW1 R
	40	7	CRW1 R	CR 16×40×7 CRW1 R
40	40	7	CRWA1 R	CR 16×40×7 CRWA1 R
	40	7	CRWA1 R	CR 16×40×7 CRWA1 R
17	27	6,35	CRW1 R	CR 17×27×6 CRW1 R
	28	7	CRW1 R	CR 17×28×7 CRW1 R
	28	7	CRW1 V	CR 17×28×7 CRW1 V
	30	7	CRW1 R	CR 17×30×7 CRW1 R
	32	7	CRW1 R	CR 17×32×7 CRW1 R
	35	7	CRW1 R	CR 17×35×7 CRW1 R
	35	7	CRW1 V	CR 17×35×7 CRW1 V
	40	7	CRW1 R	CR 17×40×7 CRW1 R
	47	7	CRW1 R	CR 17×47×7 CRW1 R

Radial shaft seals – CRW1, CRWA1, CRWH1 and CRWHA1 – metric dimensions
 d_1 18 – 28 mm

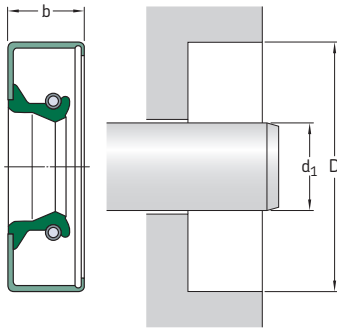

Please see **pages 74 to 76** for housing bore requirements.

Dimensions	Bore	Nominal seal width	Design and lip material	Designation
Shaft	D	b		
d_1				
mm			–	–
18	30 30 32 32	7 7 7 7	CRW1 R CRW1 V CRW1 R CRW1 V	CR 18×30×7 CRW1 R CR 18×30×7 CRW1 V CR 18×32×7 CRW1 R CR 18×32×7 CRW1 V
	35 40	7 7	CRW1 R CRW1 R	CR 18×35×7 CRW1 R CR 18×40×7 CRW1 R
19	35	7	CRW1 R	CR 19×35×7 CRW1 R
20	30 31 32	7 7 7	CRW1 R CRW1 R CRW1 R	CR 20×30×7 CRW1 R CR 20×31×7 CRW1 R CR 20×32×7 CRW1 R
	35 35 36 36	7 7 7 7	CRW1 R CRW1 V CRW1 R CRW1 V	CR 20×35×7 CRW1 R CR 20×35×7 CRW1 V CR 20×36×7 CRW1 R CR 20×36×7 CRW1 V
	37 38	7 7	CRW1 R CRW1 R	CR 20×37×7 CRW1 R CR 20×38×7 CRW1 R
	40 40 42 47	7 7 7 7	CRW1 R CRW1 V CRW1 R CRW1 R	CR 20×40×7 CRW1 R CR 20×40×7 CRW1 V CR 20×42×7 CRW1 R CR 20×47×7 CRW1 R
	52 52	7 7	CRW1 R CRW1 P	CR 20×52×7 CRW1 R CR 20×52×7 CRW1 P
21	35 35 40	7 7 8	CRW1 R CRW1 V CRW1 R	CR 21×35×7 CRW1 R CR 21×35×7 CRW1 V CR 21×40×8 CRW1 R

Dimensions Shaft	Bore	Nominal seal width b	Design and lip material	Designation
d ₁	D			
mm			–	–
22	31	7	CRW1 P	CR 22×31×7 CRW1 P
	32	7	CRW1 R	CR 22×32×7 CRW1 R
	35	7	CRW1 R	CR 22×35×7 CRW1 R
	35	7	CRW1 V	CR 22×35×7 CRW1 V
	38	7	CRW1 R	CR 22×38×7 CRW1 R
	38	7	CRW1 V	CR 22×38×7 CRW1 V
	38	7	CRW1 V	CR 22×38×7 CRW1 V
	40	6,35	CRW1 R	CR 22×40×6 CRW1 R
	40	6,35	CRW1 V	CR 22×40×6 CRW1 V
	42	7	CRW1 R	CR 22×42×7 CRW1 R
	47	8	CRW1 R	CR 22×47×8 CRW1 R
	50	8	CRW1 R	CR 22×50×8 CRW1 R
24	36	7	CRW1 V	CR 24×36×7 CRW1 V
	38	7	CRW1 V	CR 24×38×7 CRW1 V
	47	8	CRW1 R	CR 24×47×8 CRW1 R
25	35	7	CRW1 R	CR 25×35×7 CRW1 R
	35	7	CRW1 V	CR 25×35×7 CRW1 V
	36	7	CRW1 R	CR 25×36×7 CRW1 R
	37	7	CRW1 R	CR 25×37×7 CRW1 R
		7	CRW1 V	CR 25×37×7 CRW1 V
	38	7	CRW1 R	CR 25×38×7 CRW1 R
	38	7	CRW1 V	CR 25×38×7 CRW1 V
	40	7	CRW1 R	CR 25×40×7 CRW1 R
		7	CRW1 R	CR 25×40×7 CRW1 R
		7	CRW1 V	CR 25×40×7 CRW1 V
	42	8	CRW1 V	CR 25×42×8 CRW1 V
		8	CRW1 R	CR 25×42×8 CRW1 R
	45	7	CRW1 R	CR 25×45×7 CRW1 R
		6,35	CRW1 R	CR 25×47×6 CRW1 R
		8	CRW1 R	CR 25×48×8 CRW1 R
8		CRW1 V	CR 25×48×8 CRW1 V	
50	8	CRW1 R	CR 25×50×8 CRW1 R	
	8	CRW1 R	CR 25×52×8 CRW1 R	
	8	CRW1 V	CR 25×52×8 CRW1 V	
62	7	CRW1 R	CR 25×62×7 CRW1 R	
	7	CRW1 V	CR 25×62×7 CRW1 V	
27	42	7	CRW1 R	CR 27×42×7 CRW1 R
	42	7	CRW1 V	CR 27×42×7 CRW1 V
	43	8	CRW1 V	CR 27×43×8 CRW1 V
	45	8	CRW1 V	CR 27×45×8 CRW1 V
	52	8	CRW1 R	CR 27×52×8 CRW1 R
28	40	7	CRW1 R	CR 28×40×7 CRW1 R
	40	7	CRW1 V	CR 28×40×7 CRW1 V
	42	7	CRW1 R	CR 28×42×7 CRW1 R
		7	CRW1 V	CR 28×42×7 CRW1 V
	45	7	CRW1 V	CR 28×45×7 CRW1 V
	47	7	CRW1 V	CR 28×47×7 CRW1 V
		8	CRW1 R	CR 28×47×8 CRW1 R
		8	CRW1 R	CR 28×52×8 CRW1 R

Radial shaft seals – CRW1, CRWA1, CRWH1 and CRWA1 – metric dimensions
 d_1 30 – 36 mm

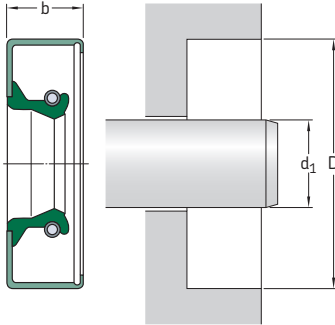

Please see **pages 74 to 76** for housing bore requirements.

Dimensions	Bore	Nominal seal width	Design and lip material	Designation
Shaft	D	b		
d_1				
mm			–	–
30	40	7	CRW1 R	CR 30x40x7 CRW1 R
	40	7	CRW1 V	CR 30x40x7 CRW1 V
	42	7	CRW1 R	CR 30x42x7 CRW1 R
	42	7	CRW1 V	CR 30x42x7 CRW1 V
	45	8	CRW1 R	CR 30x45x8 CRW1 R
	45	8	CRW1 P	CR 30x45x8 CRW1 P
	47	7	CRW1 R	CR 30x47x7 CRW1 R
	47	8	CRW1 V	CR 30x47x8 CRW1 V
	48	8	CRW1 R	CR 30x48x8 CRW1 R
	50	8	CRW1 R	CR 30x50x8 CRW1 R
	50	8	CRW1 V	CR 30x50x8 CRW1 V
	52	8	CRW1 R	CR 30x52x8 CRW1 R
	55	7	CRW1 R	CR 30x55x7 CRW1 R
	56	8	CRW1 R	CR 30x56x8 CRW1 R
	58	8	CRWA1 R	CR 30x58x8 CRWA1 R
	60	8	CRW1 R	CR 30x60x8 CRW1 R
	62	7	CRW1 R	CR 30x62x7 CRW1 R
	62	7	CRW1 V	CR 30x62x7 CRW1 V
	72	8	CRW1 R	CR 30x72x8 CRW1 R
	72	12	CRWA1 V	CR 30x72x12 CRWA1 V
32	42	7	CRW1 R	CR 32x42x7 CRW1 R
	42	7	CRW1 V	CR 32x42x7 CRW1 V
	45	8	CRW1 R	CR 32x45x8 CRW1 R
	47	8	CRW1 R	CR 32x47x8 CRW1 R
	47	8	CRW1 V	CR 32x47x8 CRW1 V
	48	8	CRW1 R	CR 32x48x8 CRW1 R
	48	8	CRW1 V	CR 32x48x8 CRW1 V
	50	8	CRW1 R	CR 32x50x8 CRW1 R
	50	8	CRW1 V	CR 32x50x8 CRW1 V
	52	8	CRW1 R	CR 32x52x8 CRW1 R
	52	8	CRW1 V	CR 32x52x8 CRW1 V

Dimensions Shaft	Bore	Nominal seal width b	Design and lip material	Designation	
d ₁	D				
mm			–	–	
32 cont.	56	8	CRW1 R	CR 32×56×8 CRW1 R	
	62	6,35	CRW1 R	CR 32×62×6 CRW1 R	
34	48	8	CRW1 R	CR 34×48×8 CRW1 R	
	48	8	CRW1 V	CR 34×48×8 CRW1 V	
	55	8	CRW1 R	CR 34×55×8 CRW1 R	
	56	8	CRW1 R	CR 34×56×8 CRW1 R	
	56	8	CRW1 V	CR 34×56×8 CRW1 V	
	62	8	CRW1 R	CR 34×62×8 CRW1 R	
	35	47	7	CRW1 R	CR 35×47×7 CRW1 R
		47	7	CRW1 V	CR 35×47×7 CRW1 V
		48	8	CRW1 R	CR 35×48×8 CRW1 R
		48	8	CRW1 V	CR 35×48×8 CRW1 V
50		8	CRW1 R	CR 35×50×8 CRW1 R	
50		8	CRW1 V	CR 35×50×8 CRW1 V	
52		8	CRWA1 P	CR 35×52×8 CRWA1 P	
52		8	CRW1 R	CR 35×52×8 CRW1 R	
52		8	CRWA1 R	CR 35×52×8 CRWA1 R	
54		7	CRW1 R	CR 35×54×7 CRW1 R	
54		8	CRW1 V	CR 35×54×8 CRW1 V	
55		8	CRW1 R	CR 35×55×8 CRW1 R	
55		8	CRW1 V	CR 35×55×8 CRW1 V ¹⁾	
56		8	CRW1 R	CR 35×56×8 CRW1 R	
56		8	CRW1 V	CR 35×56×8 CRW1 V	
62		8	CRW1 V	CR 35×62×8 CRW1 V	
62		8	CRW1 R	CR 35×62×8 CRW1 R	
64		8	CRW1 R	CR 35×64×8 CRW1 R	
65	8	CRW1 V	CR 35×65×8 CRW1 V		
68	8	CRW1 R	CR 35×68×8 CRW1 R		
68	8	CRW1 V	CR 35×68×8 CRW1 V		
69	8	CRW1 R	CR 35×69×8 CRW1 R		
72	8	CRW1 V	CR 35×72×8 CRW1 V		
72	8	CRW1 R	CR 35×72×8 CRW1 R		
72	8	CRWA1 R	CR 35×72×8 CRWA1 R		
78	8	CRW1 R	CR 35×78×8 CRW1 R		
80	8	CRW1 R	CR 35×80×8 CRW1 R		
36	50	7	CRW1 R	CR 36×50×7 CRW1 R	
	50	8	CRW1 R	CR 36×50×8 CRW1 R	
	52	8	CRW1 R	CR 36×52×8 CRW1 R	
	52	8	CRW1 V	CR 36×52×8 CRW1 V	
	54	8	CRW1 R	CR 36×54×8 CRW1 R	
	54	8	CRW1 V	CR 36×54×8 CRW1 V	
	58	8	CRW1 R	CR 36×58×8 CRW1 R	
	60	8	CRW1 R	CR 36×60×8 CRW1 R	
	60	8	CRW1 V	CR 36×60×8 CRW1 V	
	62	8	CRW1 R	CR 36×62×8 CRW1 R	
	65	8	CRW1 R	CR 36×65×8 CRW1 R	
	68	8	CRW1 R	CR 36×68×8 CRW1 R	

¹⁾ Without SKF Bore Tite Coating

Radial shaft seals – CRW1, CRWA1, CRWH1 and CRWHA1 – metric dimensions
 d_1 38 – 43 mm

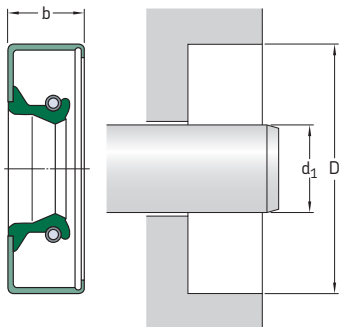

Please see **pages 74 to 76** for housing bore requirements.

Dimensions	Bore	Nominal seal width	Design and lip material	Designation
Shaft	D	b		
d_1				
mm			–	–
38	50	7	CRW1 R	CR 38×50×7 CRW1 R
	50	7	CRW1 V	CR 38×50×7 CRW1 V
	52	8	CRW1 R	CR 38×52×8 CRW1 R
	52	8	CRWA1 R	CR 38×52×8 CRWA1 R
	52	8	CRW1 V	CR 38×52×8 CRW1 V
	53	8	CRW1 R	CR 38×53×8 CRW1 R
	54	7	CRW1 P	CR 38×54×7 CRW1 P ¹⁾
	55	8	CRW1 R	CR 38×55×8 CRW1 R
	55	8	CRW1 V	CR 38×55×8 CRW1 V
	56	8	CRW1 V	CR 38×56×8 CRW1 V
	56	8	CRW1 R	CR 38×56×8 CRW1 R
	58	8	CRW1 R	CR 38×58×8 CRW1 R
	58	8	CRW1 V	CR 38×58×8 CRW1 V
	60	8	CRW1 R	CR 38×60×8 CRW1 R
	60	8	CRW1 V	CR 38×60×8 CRW1 V
	62	8	CRW1 R	CR 38×62×8 CRW1 R
	62	8	CRWA1 R	CR 38×62×8 CRWA1 R
	62	8	CRW1 V	CR 38×62×8 CRW1 V
	65	8	CRW1 R	CR 38×65×8 CRW1 R
	68	8	CRW1 R	CR 38×68×8 CRW1 R
	70	8	CRW1 R	CR 38×70×8 CRW1 R
	72	8	CRW1 R	CR 38×72×8 CRW1 R
	73	8	CRW1 R	CR 38×73×8 CRW1 R
	74	11	CRWA1 R	CR 38×74×11 CRWA1 R
	74	11	CRW1 V	CR 38×74×11 CRW1 V
	80	8	CRW1 R	CR 38×80×8 CRW1 R
	90	8	CRWA1 R	CR 38×90×8 CRWA1 R

¹⁾ Without SKF Bore Tite Coating

Dimensions Shaft	Bore	Nominal seal width b	Design and lip material	Designation
d ₁	D	b		
mm			–	–
40	52	7	CRW1 V	CR 40×52×7 CRW1 V
	52	7	CRW1 R	CR 40×52×7 CRW1 R
	54	7	CRW1 R	CR 40×54×7 CRW1 R
	55	8	CRW1 R	CR 40×55×8 CRW1 R
	55	8	CRW1 V	CR 40×55×8 CRW1 V
	56	7	CRW1 V	CR 40×56×7 CRW1 V
	56	8	CRW1 R	CR 40×56×8 CRW1 R
	57	8	CRW1 R	CR 40×57×8 CRW1 R
	58	8	CRW1 R	CR 40×58×8 CRW1 R
	58	8	CRW1 V	CR 40×58×8 CRW1 V
	60	8	CRW1 R	CR 40×60×8 CRW1 R
	60	8	CRW1 V	CR 40×60×8 CRW1 V
	62	8	CRW1 R	CR 40×62×8 CRW1 R
	62	8	CRW1 V	CR 40×62×8 CRW1 V
	65	8	CRW1 R	CR 40×65×8 CRW1 R
	68	8	CRW1 R	CR 40×68×8 CRW1 R
	70	8	CRW1 R	CR 40×70×8 CRW1 R
	72	8	CRW1 R	CR 40×72×8 CRW1 R
	74	8	CRW1 R	CR 40×74×8 CRW1 R
	75	8	CRW1 V	CR 40×75×8 CRW1 V
	80	8	CRW1 R	CR 40×80×8 CRW1 R
80	8	CRW1 V	CR 40×80×8 CRW1 V ¹⁾	
90	8	CRW1 R	CR 40×90×8 CRW1 R	
41	53	7	CRW1 R	CR 41×53×7 CRW1 R
	55	8	CRW1 R	CR 41×55×8 CRW1 R
	62	8	CRW1 R	CR 41×62×8 CRW1 R
42	55	8	CRW1 R	CR 42×55×8 CRW1 R
	55	8	CRW1 V	CR 42×55×8 CRW1 V
	56	7	CRW1 V	CR 42×56×7 CRW1 V
	56	8	CRW1 R	CR 42×56×8 CRW1 R
	58	8	CRW1 R	CR 42×58×8 CRW1 R
	58	8	CRW1 V	CR 42×58×8 CRW1 V
	60	8	CRW1 R	CR 42×60×8 CRW1 R
	60	8	CRW1 V	CR 42×60×8 CRW1 V
	62	8	CRW1 R	CR 42×62×8 CRW1 R
	62	8	CRW1 V	CR 42×62×8 CRW1 V
	65	8	CRW1 R	CR 42×65×8 CRW1 R
	65	8	CRW1 V	CR 42×65×8 CRW1 V
72	8	CRW1 V	CR 42×72×8 CRW1 V	
72	8	CRW1 R	CR 42×72×8 CRW1 R	
43	57	8	CRW1 R	CR 43×57×8 CRW1 R
	60	8	CRW1 R	CR 43×60×8 CRW1 R
	69	8	CRW1 R	CR 43×69×8 CRW1 R
	73	8	CRW1 R	CR 43×73×8 CRW1 R

¹⁾ Without SKF Bore Tite Coating

Radial shaft seals – CRW1, CRWA1, CRWH1 and CRWHA1 – metric dimensions
 d_1 44 – 54 mm

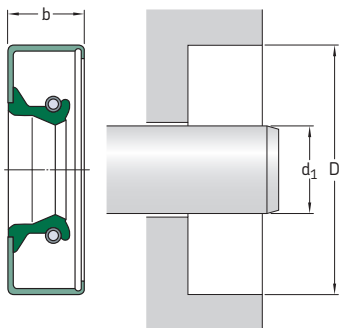

Please see pages 74 to 76 for housing bore requirements.

Dimensions Shaft	Bore	Nominal seal width b	Design and lip material	Designation
d_1	D	b		
mm			–	–
44	60	8	CRW1 R	CR 44×60×8 CRW1 R
	60	8	CRW1 V	CR 44×60×8 CRW1 V ¹⁾
	62	8	CRW1 R	CR 44×62×8 CRW1 R
	65	8	CRW1 R	CR 44×65×8 CRW1 R
	68	8	CRW1 V	CR 44×68×8 CRW1 V
	70	8	CRW1 R	CR 44×70×8 CRW1 R
45	72	8	CRW1 R	CR 44×72×8 CRW1 R
	60	8	CRW1 R	CR 45×60×8 CRW1 R
	60	8	CRW1 V	CR 45×60×8 CRW1 V
	62	8	CRWA1 V	CR 45×62×8 CRWA1 V
	62	8	CRW1 R	CR 45×62×8 CRW1 R
	65	8	CRW1 R	CR 45×65×8 CRW1 R
	65	8	CRW1 V	CR 45×65×8 CRW1 V
	68	8	CRW1 R	CR 45×68×8 CRW1 R
	68	8	CRW1 V	CR 45×68×8 CRW1 V
	68	8	CRWA1 R	CR 45×68×8 CRWA1 R
	72	8	CRW1 V	CR 45×72×8 CRW1 V
	72	8	CRW1 R	CR 45×72×8 CRW1 R
	75	8	CRW1 R	CR 45×75×8 CRW1 R
	75	8	CRW1 V	CR 45×75×8 CRW1 V
	80	8	CRW1 R	CR 45×80×8 CRW1 R
85	8	CRW1 R	CR 45×85×8 CRW1 R	
46	60	8	CRW1 R	CR 46×60×8 CRW1 R
	65	8	CRW1 R	CR 46×65×8 CRW1 R
	68	8	CRW1 R	CR 46×68×8 CRW1 R
	72	8	CRW1 R	CR 46×72×8 CRW1 R
	73	8	CRW1 R	CR 46×73×8 CRW1 R

Dimensions Shaft	Bore	Nominal seal width b	Design and lip material	Designation	
d ₁	D				
mm			–	–	
47	60	7	CRW1 R	CR 47×60×7 CRW1 R	
	62	8	CRW1 R	CR 47×62×8 CRW1 R	
	72	8	CRW1 R	CR 47×72×8 CRW1 R	
48	62	8	CRW1 R	CR 48×62×8 CRW1 R	
	62	8	CRW1 P	CR 48×62×8 CRW1 P	
	65	8	CRW1 R	CR 48×65×8 CRW1 R	
	65	8	CRW1 V	CR 48×65×8 CRW1 V	
	68	8	CRW1 V	CR 48×68×8 CRW1 V	
	70	8	CRW1 R	CR 48×70×8 CRW1 R	
	70	8	CRW1 V	CR 48×70×8 CRW1 V	
	72	8	CRW1 R	CR 48×72×8 CRW1 R	
	72	8	CRW1 V	CR 48×72×8 CRW1 V	
	80	8	CRW1 R	CR 48×80×8 CRW1 R	
	50	65	8	CRW1 R	CR 50×65×8 CRW1 R
		65	8	CRW1 V	CR 50×65×8 CRW1 V
68		8	CRW1 R	CR 50×68×8 CRW1 R	
68		8	CRW1 V	CR 50×68×8 CRW1 V	
70		8	CRW1 R	CR 50×70×8 CRW1 R	
70		8	CRW1 V	CR 50×70×8 CRW1 V	
72		8	CRW1 R	CR 50×72×8 CRW1 R	
72		8	CRW1 V	CR 50×72×8 CRW1 V	
75		8	CRWA1 R	CR 50×75×8 CRWA1 R	
80		8	CRW1 R	CR 50×80×8 CRW1 R	
80		8	CRW1 V	CR 50×80×8 CRW1 V	
82		8	CRWA1 R	CR 50×82×8 CRWA1 R	
85		8	CRW1 R	CR 50×85×8 CRW1 R	
90		8	CRW1 R	CR 50×90×8 CRW1 R	
90		8	CRW1 V	CR 50×90×8 CRW1 V	
51	65	7	CRWA1 R	CR 51×65×7 CRWA1 R	
	73	8	CRW1 R	CR 51×73×8 CRW1 R	
	80	9,53	CRW1 R	CR 51×80×10 CRW1 R	
	81	9,53	CRWH1 R	CR 51×81×10 CRWH1 R	
	81	9,53	CRWHA1 R	CR 51×81×10 CRWHA1 R	
	92	11,13	CRWH1 R	CR 51×92×11 CRWH1 R	
52	68	8	CRW1 R	CR 52×68×8 CRW1 R	
	68	8	CRW1 V	CR 52×68×8 CRW1 V	
	70	8	CRW1 R	CR 52×70×8 CRW1 R	
	72	8	CRWA1 V	CR 52×72×8 CRWA1 V	
	72	8	CRW1 R	CR 52×72×8 CRW1 R	
	72	8	CRW1 V	CR 52×72×8 CRW1 V	
	85	8	CRW1 R	CR 52×85×8 CRW1 R	
53	68	8	CRW1 V	CR 53×68×8 CRW1 V	
54	65	8	CRW1 R	CR 54×65×8 CRW1 R	
	65	8	CRW1 V	CR 54×65×8 CRW1 V	
	73	11,13	CRW1 R	CR 54×73×11 CRW1 R	
	73	11,13	CRWA1 R	CR 54×73×11 CRWA1 R	
	81	9,53	CRWA1 R	CR 54×81×10 CRWA1 R	

Radial shaft seals – CRW1, CRWA1, CRWH1 and CRWHA1 – metric dimensions
 d_1 55 – 70 mm

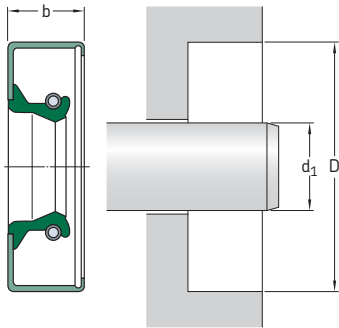

Please see **pages 74 to 76** for housing bore requirements.

Dimensions		Nominal seal width b	Design and lip material	Designation
Shaft	Bore			
d_1	D			
mm			–	–
55	70	8	CRW1 R	CR 55×70×8 CRW1 R
	70	8	CRW1 V	CR 55×70×8 CRW1 V
	72	8	CRW1 R	CR 55×72×8 CRW1 R
	72	8	CRW1 V	CR 55×72×8 CRW1 V
	73	8	CRW1 V	CR 55×73×8 CRW1 V
	75	8	CRW1 R	CR 55×75×8 CRW1 R
	75	8	CRW1 V	CR 55×75×8 CRW1 V
	80	8	CRW1 R	CR 55×80×8 CRW1 R
	80	8	CRW1 V	CR 55×80×8 CRW1 V
	85	8	CRW1 R	CR 55×85×8 CRW1 R
	90	8	CRW1 R	CR 55×90×8 CRW1 R
	100	8	CRW1 R	CR 55×100×8 CRW1 R
56	75	8	CRW1 R	CR 56×75×8 CRW1 R
57	81	11	CRW1 R	CR 57×81×11 CRW1 R
	81	11	CRWA1 P	CR 57×81×11 CRWA1 P
	92	11	CRWH1 R	CR 57×92×11 CRWH1 R
	92	11	CRWHA1 R	CR 57×92×11 CRWHA1 R
58	72	8	CRW1 R	CR 58×72×8 CRW1 R
	72	8	CRW1 S	CR 58×72×8 CRW1 S
	75	8	CRW1 R	CR 58×75×8 CRW1 R
	80	8	CRW1 R	CR 58×80×8 CRW1 R
	80	8	CRW1 V	CR 58×80×8 CRW1 V
	85	8	CRW1 R	CR 58×85×8 CRW1 R
	90	8	CRW1 R	CR 58×90×8 CRW1 R

Dimensions Shaft	Bore	Nominal seal width b	Design and lip material	Designation
d_1	D			
mm			–	–
60	75	8	CRW1 R	CR 60×75×8 CRW1 R
	75	8	CRW1 V	CR 60×75×8 CRW1 V
	80	8	CRW1 R	CR 60×80×8 CRW1 R
	80	8	CRW1 V	CR 60×80×8 CRW1 V
	82	8	CRWA1 R	CR 60×82×8 CRWA1 R
	85	8	CRW1 V	CR 60×85×8 CRW1 V
	85	8	CRW1 R	CR 60×85×8 CRW1 R
	90	8	CRW1 R	CR 60×90×8 CRW1 R
	105	8	CRW1 R	CR 60×105×8 CRW1 R
	110	8	CRW1 R	CR 60×110×8 CRW1 R
62	80	8	CRW1 V	CR 62×80×8 CRW1 V
	85	8	CRW1 R	CR 62×85×8 CRW1 R
	90	8	CRW1 R	CR 62×90×8 CRW1 R
	90	11,13	CRWH1 R	CR 62×90×11 CRWH1 R
63	78	8	CRW1 R	CR 63×78×8 CRW1 R
	80	8	CRW1 R	CR 63×80×8 CRW1 R
	85	8	CRW1 R	CR 63×85×8 CRW1 R
	88	8	CRW1 R	CR 63×88×8 CRW1 R
65	80	8	CRW1 R	CR 65×80×8 CRW1 R
	80	8	CRW1 V	CR 65×80×8 CRW1 V
	85	8	CRW1 R	CR 65×85×8 CRW1 R
	85	8	CRW1 V	CR 65×85×8 CRW1 V
	88	8	CRW1 R	CR 65×88×8 CRW1 R
	90	8	CRW1 R	CR 65×90×8 CRW1 R
	90	8	CRW1 V	CR 65×90×8 CRW1 V
	92	11,13	CRWH1 R	CR 65×92×11 CRWH1 R
	100	8	CRW1 R	CR 65×100×8 CRW1 R
	100	8	CRW1 V	CR 65×100×8 CRW1 V
110	10	CRW1 R	CR 65×110×10 CRW1 R	
120	8	CRW1 R	CR 65×120×8 CRW1 R	
68	85	8	CRW1 R	CR 68×85×8 CRW1 R
	88	8	CRW1 R	CR 68×88×8 CRW1 R
	90	8	CRW1 R	CR 68×90×8 CRW1 R
	90	8	CRW1 V	CR 68×90×8 CRW1 V
	95	10	CRW1 R	CR 68×95×10 CRW1 R
	95	10	CRW1 V	CR 68×95×10 CRW1 V
	100	10	CRW1 R	CR 68×100×10 CRW1 R
70	85	8	CRW1 R	CR 70×85×8 CRW1 R
	88	8	CRW1 R	CR 70×88×8 CRW1 R
	88	8	CRW1 V	CR 70×88×8 CRW1 V
	90	8	CRW1 R	CR 70×90×8 CRW1 R
	90	10	CRW1 V	CR 70×90×10 CRW1 V
	90	10	CRWHA1 P	CR 70×90×10 CRWHA1 P
	92	11	CRWH1 R	CR 70×92×11 CRWH1 R
	92	11	CRWH1 V	CR 70×92×11 CRWH1 V
	95	10	CRW1 R	CR 70×95×10 CRW1 R
	100	10	CRW1 R	CR 70×100×10 CRW1 R
105	10	CRW1 R	CR 70×105×10 CRW1 R	

Radial shaft seals – CRW1, CRWA1, CRWH1 and CRWA1 – metric dimensions
 d_1 70 – 110 mm

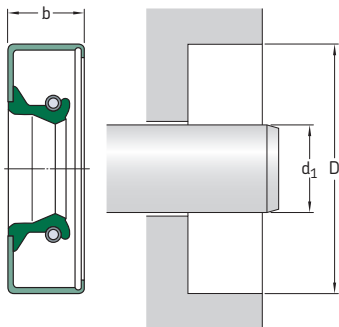

Please see **pages 74 to 76** for housing bore requirements.

Dimensions Shaft	Bore	Nominal seal width b	Design and lip material	Designation
d_1	D			
mm			–	–
70	110	10	CRW1 R	CR 70x110x10 CRW1 R
cont.	110	12,70	CRWHA1 R	CR 70x110x13 CRWHA1 R ¹⁾
72	88	8	CRW1 R	CR 72x88x8 CRW1 R
73	92	11,13	CRWH1 R	CR 73x92x11 CRWH1 R
	110	11,13	CRWA1 P	CR 73x110x11 CRWA1 P
75	90	8	CRW1 R	CR 75x90x8 CRW1 R
	95	10	CRW1 R	CR 75x95x10 CRW1 R
	95	10	CRW1 V	CR 75x95x10 CRW1 V
	100	10	CRW1 R	CR 75x100x10 CRW1 R
	100	10	CRW1 V	CR 75x100x10 CRW1 V
	105	10	CRW1 R	CR 75x105x10 CRW1 R
	110	10	CRW1 R	CR 75x110x10 CRW1 R
	115	12	CRW1 R	CR 75x115x12 CRW1 R
80	100	10	CRW1 R	CR 80x100x10 CRW1 R
	100	10	CRW1 V	CR 80x100x10 CRW1 V
	105	10	CRW1 R	CR 80x105x10 CRW1 R
	105	10	CRW1 V	CR 80x105x10 CRW1 V
	110	10	CRW1 R	CR 80x110x10 CRW1 R
	125	10	CRW1 R	CR 80x125x10 CRW1 R
	125	10	CRW1 V	CR 80x125x10 CRW1 V
	130	12	CRWA1 R	CR 80x130x12 CRWA1 R
	140	12	CRW1 R	CR 80x140x12 CRW1 R
84	127	11	CRWH1 R	CR 84x127x11 CRWH1 R

Dimensions Shaft d ₁	Bore D	Nominal seal width b	Design and lip material	Designation	
mm			–	–	
85	105	10	CRW1 R	CR 85×105×10 CRW1 R	
	105	10	CRW1 V	CR 85×105×10 CRW1 V	
	110	10	CRW1 R	CR 85×110×10 CRW1 R	
	110	10	CRWA1 V	CR 85×110×10 CRWA1 V	
	120	12	CRW1 R	CR 85×120×12 CRW1 R	
	130	12	CRW1 R	CR 85×130×12 CRW1 R	
89	127	11,13	CRWH1 R	CR 89×127×11 CRWH1 R	
90	110	12	CRW1 R	CR 90×110×12 CRW1 R	
	110	12	CRW1 V	CR 90×110×12 CRW1 V	
	115	12	CRWA1 R	CR 90×115×12 CRWA1 R	
	120	12	CRW1 R	CR 90×120×12 CRW1 R	
	120	12	CRW1 V	CR 90×120×12 CRW1 V	
	125	12	CRW1 R	CR 90×125×12 CRW1 R	
	125	12	CRW1 V	CR 90×125×12 CRW1 V	
	130	12	CRW1 R	CR 90×130×12 CRW1 R	
	140	12	CRWA1 R	CR 90×140×12 CRWA1 R	
	92	127	11	CRWHA1 R	CR 92×127×11 CRWHA1 R
127		11,13	CRWH1 R	CR 92×127×11 CRWH1 R	
95	110	10	CRW1 R	CR 95×110×10 CRW1 R	
	115	12	CRW1 R	CR 95×115×12 CRW1 R	
	115	12	CRW1 V	CR 95×115×12 CRW1 V	
	120	12	CRW1 R	CR 95×120×12 CRW1 R	
	120	12	CRW1 V	CR 95×120×12 CRW1 V	
	120	12	CRWA1 V	CR 95×120×12 CRWA1 V	
	125	12	CRW1 R	CR 95×125×12 CRW1 R	
	130	12	CRW1 R	CR 95×130×12 CRW1 R	
	130	12	CRW1 V	CR 95×130×12 CRW1 V	
	98	120	12	CRW1 V	CR 98×120×12 CRW1 V
120		12	CRW1 R	CR 98×120×12 CRW1 R	
100	120	12	CRW1 R	CR 100×120×12 CRW1 R	
	120	12	CRW1 V	CR 100×120×12 CRW1 V	
	125	12	CRW1 R	CR 100×125×12 CRW1 R	
	125	12	CRW1 V	CR 100×125×12 CRW1 V	
	127	11,13	CRWH1 R	CR 100×127×11 CRWH1 R	
	130	12	CRW1 R	CR 100×130×12 CRW1 R	
	135	12	CRWA1 R	CR 100×135×12 CRWA1 R	
	140	12	CRWA1 R	CR 100×140×12 CRWA1 R	
	105	127	11,13	CRWH1 R	CR 105×127×11 CRWH1 R
		130	12	CRW1 R	CR 105×130×12 CRW1 R
130		12	CRW1 V	CR 105×130×12 CRW1 V	
135		12	CRWA1 R	CR 105×135×12 CRWA1 R	
140		12	CRWA1 R	CR 105×140×12 CRWA1 R	
160		12	CRW1 R	CR 105×160×12 CRW1 R	
110	130	12	CRW1 R	CR 110×130×12 CRW1 R	
	130	12	CRW1 V	CR 110×130×12 CRW1 V	
	135	12	CRW1 V	CR 110×135×12 CRW1 V	
	140	12	CRW1 V	CR 110×140×12 CRW1 V	
	140	12	CRW1 R	CR 110×140×12 CRW1 R	
	145	12	CRW1 R	CR 110×145×12 CRW1 R	
160	12	CRWH1 R	CR 110×160×12 CRWH1 R		

Radial shaft seals – CRW1, CRWA1, CRWH1 and CRWA1 – metric dimensions
 d_1 115 – 280 mm

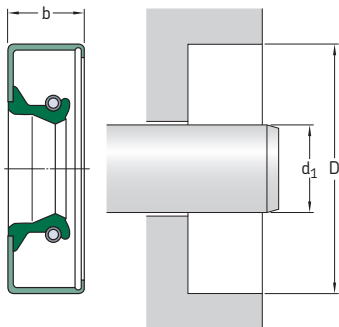

Please see pages 74 to 76 for housing bore requirements.

Dimensions		Nominal seal width b	Design and lip material	Designation
Shaft	Bore			
d_1	D			
mm			–	–
115	135	12	CRW1 R	CR 115×135×12 CRW1 R
	140	12	CRW1 R	CR 115×140×12 CRW1 R
	140	12	CRW1 R	CR 115×140×12 CRW1 R
	140	12	CRW1 V	CR 115×140×12 CRW1 V
	145	12	CRW1 R	CR 115×145×12 CRW1 R
	150	12	CRW1 R	CR 115×150×12 CRW1 R
	160	12	CRW1 R	CR 115×160×12 CRW1 R
120	140	12	CRWA1 R	CR 120×140×12 CRWA1 R
	145	12	CRW1 R	CR 120×145×12 CRW1 R
	150	12	CRW1 R	CR 120×150×12 CRW1 R
	160	12	CRWH1 R	CR 120×160×12 CRWH1 R
125	150	12	CRW1 R	CR 125×150×12 CRW1 R
	150	12	CRW1 V	CR 125×150×12 CRW1 V
	160	12	CRW1 R	CR 125×160×12 CRW1 R
130	160	12	CRW1 R	CR 130×160×12 CRW1 R
	160	12	CRW1 V	CR 130×160×12 CRW1 V
	170	12	CRW1 R	CR 130×170×12 CRW1 R
140	160	12	CRW1 R	CR 140×160×12 CRW1 R
	170	12	CRW1 R	CR 140×170×12 CRW1 R
	170	12	CRW1 V	CR 140×170×12 CRW1 V ¹⁾
143	181	12,70	CRWHA1 R	CR 143×181×13 CRWHA1 R
160	190	15	CRW1 V	CR 160×190×15 CRW1 V
162	200	14,30	CRWHA1 R	CR 162×200×14 CRWHA1 R
	200	15,88	CRWH1 R	CR 162×200×16 CRWH1 R
188	215	16	CRWH1 R	CR 188×215×16 CRWH1 R
203	254	15,88	CRWHA1 R	CR 203×254×16 CRWHA1 R ¹⁾

¹⁾ Without SKF Bore Tite Coating

Dimensions			Design and lip material	Designation
Shaft	Bore	Nominal seal width		
d_1	D	b		
mm			–	–
216	254	15,88	CRWH1 R	CR 216×254×16 CRWH1 R
220	250	16	CRWH1 R	CR 220×250×16 CRWH1 R
280	320	20	CRWA1 R	CR 280×320×20 CRWA1 R
	320	20	CRWA1 V	CR 280×320×20 CRWA1 V

2.2

Radial shaft seals – CRW1, CRWA1, CRWH1 and CRWA1 – inch dimensions

d_1 0.250 – 0.669 in.

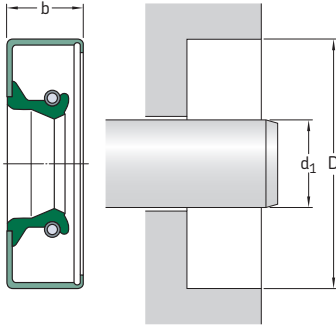

Please see pages 74 to 76 for housing bore requirements.

Dimensions Shaft	Bore	Nominal seal width b	Design and lip material	Designation	
d_1	D	b			
in.			–	–	
0.250	0.749	0.250	CRW1 V	CR 2513 ¹⁾	
	0.749	0.250	CRW1 R	CR 2514	
0.375	0.749	0.250	CRW1 R	CR 3687 ¹⁾	
	0.749	0.250	CRW1 V	CR 3688	
	0.750	0.250	CRWA1 R	CR 3680	
	0.836	0.188	CRW1 P	CR 3719	
	0.875	0.250	CRW1 R	CR 3725	
	0.999	0.250	CRW1 R	CR 3751 ¹⁾	
	0.999	0.250	CRW1 V	CR 3752	
	1.124	0.250	CRW1 R	CR 3806 ¹⁾	
	0.438	0.875	0.250	CRW1 P	CR 4249
		0.875	0.250	CRW1 R	CR 4251 ¹⁾
0.875		0.375	CRWA1 R	CR 4261 ¹⁾	
0.875		0.375	CRWA1 V	CR 4262	
0.999		0.250	CRW1 V	CR 4356	
0.999		0.375	CRW1 P	CR 4353	
0.999		0.375	CRW1 R	CR 4355	
1.124		0.250	CRW1 R	CR 4390	
0.500		0.875	0.250	CRW1 R	CR 4931
		0.875	0.250	CRW1 V	CR 4932
	0.875	0.250	CRWA1 V	CR 4933	
	0.875	0.250	CRWA1 V	CR 4935	
	0.875	0.250	CRW1 D	CR 4936	
	0.875	0.313	CRWA1 R	CR 4939	
	0.987	0.250	CRW1 R	CR 4943	
	0.999	0.250	CRW1 V	CR 4980	
	0.999	0.250	CRW1 R	CR 4984	
	0.999	0.250	CRWA1 R	CR 4985	
	1.124	0.250	CRW1 P	CR 5045	
	1.124	0.250	CRWA1 R	CR 5062	
	1.124	0.250	CRW1 V	CR 5066	

¹⁾ Without SKF Bore Tite Coating

Dimensions Shaft	Bore	Nominal seal width b	Design and lip material	Designation
d ₁	D			
in.			–	–
0.500	1.124	0.250	CRWA1 V	CR 5067
cont.	1.124	0.250	CRW1 R	CR 5068
	1.124	0.313	CRW1 P	CR 5046
	1.250	0.250	CRW1 R	CR 5133
	1.375	0.250	CRW1 R	CR 5150
	1.375	0.250	CRW1 V	CR 5151
0.531	0.999	0.250	CRWA1 S	CR 5321
0.546	0.875	0.250	CRW1 P	CR 5385¹⁾
0.554	0.999	0.250	CRW1 R	CR 5605
0.563	0.875	0.188	CRW1 D	CR 5523
	0.999	0.250	CRW1 R	CR 5541
	0.999	0.250	CRW1 V	CR 5542
	0.999	0.250	CRW1 R	CR 5543
	0.999	0.250	CRWA1 R	CR 5606
	1.124	0.250	CRW1 V	CR 5650
	1.124	0.250	CRW1 R	CR 5652
	1.124	0.250	CRWA1 R	CR 5662
	1.250	0.250	CRW1 R	CR 5707
	1.375	0.250	CRW1 R	CR 5756
0.594	1.124	0.313	CRW1 R	CR 5926
	1.124	0.313	CRW1 V	CR 5927
0.625	0.987	0.250	CRW1 R	CR 6134
	0.999	0.250	CRWA1 V	CR 6139
	0.999	0.250	CRWA1 R	CR 6141
	0.999	0.250	CRW1 R	CR 6143
	1.063	0.250	CRW1 R	CR 6157
	1.124	0.250	CRW1 R	CR 6903
	1.124	0.250	CRWA1 R	CR 6904
	1.124	0.250	CRW1 V	CR 6823
	1.124	0.250	CRWA1 V	CR 6825
	1.181	0.250	CRWA1 R	CR 6247
	1.181	0.256	CRWA1 V	CR 6248
	1.250	0.250	CRW1 V	CR 6909
	1.250	0.250	CRW1 R	CR 6925
	1.250	0.250	CRWA1 R	CR 6916
	1.375	0.250	CRW1 R	CR 6372
	1.375	0.250	CRWA1 R	CR 6373
	1.375	0.250	CRW1 V	CR 6379
	1.375	0.250	CRWA1 V	CR 6383
	1.377	0.250	CRWHA1 R	CR 6391
	1.499	0.250	CRW1 R	CR 6422
0.656	1.124	0.313	CRW1 R	CR 6521
	1.250	0.250	CRW1 R	CR 6541
	1.375	0.313	CRW1 R	CR 6556
	1.575	0.250	CRW1 R	CR 6582
0.669	0.999	0.188	CRW1 R	CR 6595
	1.064	0.250	CRW1 R	CR 6728
	1.064	0.250	CRW1 R	CR 6729
	1.573	0.281	CRW1 V	CR 6597¹⁾

¹⁾ Without SKF Bore Tite Coating

Radial shaft seals – CRW1, CRWA1, CRWH1 and CRWA1 – inch dimensions
 d_1 0.688 – 0.875 in.

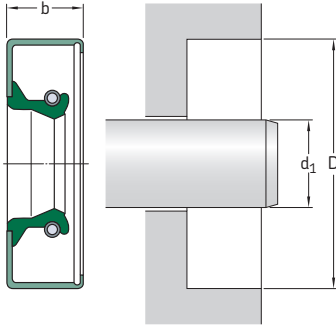

Please see pages 74 to 76 for housing bore requirements.

Dimensions Shaft	Bore	Nominal seal width b	Design and lip material	Designation	
d_1	D	b			
in.			–	–	
0.688	1.124	0.190	CRW1 R	CR 6738	
	1.124	0.250	CRW1 R	CR 6741	
	1.124	0.250	CRW1 R	CR 6743	
	1.124	0.250	CRW1 V	CR 6745	
	1.187	0.188	CRW1 V	CR 6770	
	1.188	0.188	CRW1 R	CR 6763	
	1.250	0.250	CRWA1 R	CR 6765	
	1.250	0.256	CRWA1 V	CR 6751	
	1.250	0.313	CRW1 R	CR 6767	
	1.250	0.313	CRW1 V	CR 6768	
	1.252	0.220	CRWH1 V	CR 6769	
	1.375	0.250	CRWA1 R	CR 6814	
	1.375	0.313	CRW1 R	CR 6816	
	1.375	0.313	CRW1 V	CR 6817	
	1.499	0.250	CRW1 R	CR 6935	
	1.624	0.250	CRWA1 R	CR 6990	
	0.750	1.124	0.188	CRW1 R	CR 7414
		1.124	0.188	CRW1 V	CR 7417
1.249		0.188	CRW1 V	CR 7467¹⁾	
1.250		0.188	CRW1 R	CR 7439	
1.250		0.188	CRW1 R	CR 7478¹⁾	
1.250		0.250	CRW1 R	CR 7438	
1.250		0.250	CRW1 R	CR 7440	
1.250		0.250	CRWA1 R	CR 7443	
1.250		0.250	CRW1 V	CR 7450	
1.250		0.250	CRWA1 V	CR 7453	
1.250		0.250	CRWA1 V	CR 7455	
1.252		0.188	CRW1 R	CR 7469	
1.260		0.250	CRW1 R	CR 7473	
1.312		0.250	CRW1 R	CR 7474	
1.312		0.250	CRWA1 R	CR 7475	
1.375		0.250	CRW1 R	CR 7512	

¹⁾ Without SKF Bore Tite Coating

Dimensions Shaft	Bore	Nominal seal width b	Design and lip material	Designation
d ₁	D			
in.			–	–
0.750	1.375	0.250	CRWA1 R	CR 7513
cont.	1.375	0.250	CRW1 V	CR 7515
	1.375	0.250	CRWA1 V	CR 7517
	1.375	0.250	CRWA1 P	CR 7533
	1.499	0.250	CRW1 V	CR 7567
	1.499	0.250	CRW1 R	CR 7572¹⁾
	1.499	0.250	CRWA1 R	CR 7573
	1.575	0.250	CRW1 R	CR 7591
	1.624	0.250	CRW1 V	CR 7623
	1.624	0.250	CRWA1 V	CR 7624
	1.624	0.250	CRW1 R	CR 7627
	1.624	0.250	CRWA1 R	CR 7628
	1.752	0.250	CRW1 R	CR 7636
	1.752	0.250	CRWA1 V	CR 7638
	1.828	0.250	CRW1 R	CR 7661
	1.874	0.250	CRW1 R	CR 7690
	2.047	0.313	CRW1 R	CR 7693
0.781	1.375	0.313	CRW1 V	CR 7824
	1.375	0.313	CRW1 R	CR 7829¹⁾
	1.499	0.313	CRW1 R	CR 7849
	1.624	0.313	CRW1 R	CR 7872
	1.828	0.250	CRW1 P	CR 7889
0.787	1.124	0.188	CRW1 R	CR 7740
0.813	1.187	0.313	CRWA1 V	CR 8013
	1.250	0.188	CRW1 R	CR 8017¹⁾
	1.250	0.188	CRW1 P	CR 8018
	1.312	0.250	CRW1 R	CR 8027
	1.375	0.375	CRW1 V	CR 8053
	1.375	0.375	CRW1 R	CR 8060
	1.499	0.250	CRW1 R	CR 8088¹⁾
	1.624	0.250	CRW1 V	CR 8178
	1.752	0.375	CRW1 R	CR 8215
0.875	1.250	0.188	CRW1 R	CR 8624
	1.250	0.250	CRW1 V	CR 8621
	1.308	0.250	CRW1 V	CR 8649
	1.375	0.250	CRW1 V	CR 8646
	1.375	0.250	CRW1 R	CR 8648
	1.437	0.250	CRW1 R	CR 8691
	1.499	0.250	CRW1 R	CR 8700
	1.499	0.250	CRWA1 R	CR 8702
	1.499	0.250	CRW1 V	CR 8704
	1.499	0.250	CRWA1 V	CR 8707
	1.499	0.313	CRW1 R	CR 8703¹⁾
	1.502	0.313	CRWA1 R	CR 8748
	1.575	0.250	CRW1 R	CR 8763
	1.624	0.250	CRWA1 R	CR 8782
	1.624	0.250	CRW1 V	CR 8795
	1.624	0.250	CRW1 R	CR 8796
	1.752	0.250	CRW1 R	CR 8821
	1.828	0.250	CRW1 R	CR 8842
	1.874	0.250	CRW1 R	CR 8860

¹⁾ Without SKF Bore Tite Coating

Radial shaft seals – CRW1, CRWA1, CRWH1 and CRWA1 – inch dimensions

d_1 0.875 – 1.063 in.

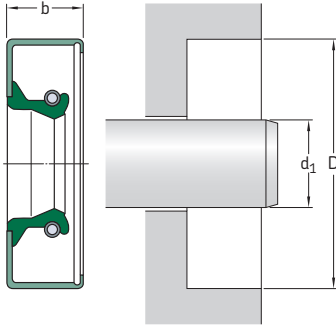

Please see pages 74 to 76 for housing bore requirements.

Dimensions Shaft	Bore	Nominal seal width b	Design and lip material	Designation
d_1	D			
in.			–	–
0.875 cont.	2.000 2.050	0.250 0.375	CRW1 R CRWH1 V	CR 8870 CR 8871
0.882	2.088	0.313	CRWA1 R	CR 9000
0.938	1.375 1.500 1.500	0.250 0.250 0.250	CRWA1 R CRW1 R CRW1 V	CR 9244 CR 9303 CR 9304
	1.624 1.624	0.250 0.250	CRW1 R CRW1 V	CR 9307 CR 9308
	1.752 1.828	0.250 0.250	CRW1 R CRW1 R	CR 9347 CR 9409
0.950	1.358	0.275	CRW1 P	CR 9520
0.969	1.406 1.499 1.499	0.250 0.313 0.313	CRWA1 P CRW1 V CRW1 R	CR 9604 CR 9611 CR 9613¹⁾
	1.624 1.624 1.686 1.686	0.250 0.250 0.313 0.313	CRW1 R CRW1 V CRWA1 R CRW1 R	CR 9646 CR 9647 CR 9663 CR 9664
	1.752 1.828	0.250 0.313	CRW1 R CRW1 R	CR 9667 CR 9681
0.981	1.376	0.313	CRW1 V	CR 9888¹⁾
0.984	1.499 1.749	0.250 0.375	CRW1 V CRWA1 V	CR 9686 CR 9803¹⁾
1.000	1.367 1.375 1.375	0.313 0.250 0.250	CRW1 R CRW1 P CRW1 V	CR 9822 CR 9826¹⁾ CR 9831

¹⁾ Without SKF Bore Tite Coating

Dimensions Shaft	Bore	Nominal seal width b	Design and lip material	Designation
d ₁	D			
in.			–	–
1.000	1.437	0.250	CRW1 V	CR 9833
cont.	1.437	0.250	CRW1 R	CR 9837
	1.437	0.250	CRWA1 R	CR 9838
	1.437	0.250	CRWA1 V	CR 9847
	1.496	0.390	CRW1 R	CR 9850
	1.499	0.250	CRW1 R	CR 9852
	1.499	0.250	CRW1 V	CR 9854
	1.499	0.250	CRW1 R	CR 9876
	1.499	0.250	CRWA1 R	CR 9878
	1.499	0.250	CRWA1 V	CR 9879
	1.499	0.315	CRWA1 V	CR 9862
	1.499	0.315	CRW1 V	CR 9892
	1.561	0.250	CRW1 R	CR 9894
	1.575	0.313	CRWA1 R	CR 9907
	1.624	0.250	CRW1 R	CR 9934
	1.624	0.250	CRWA1 R	CR 9935
	1.624	0.250	CRW1 V	CR 9937
	1.624	0.250	CRWA1 V	CR 9939
	1.686	0.250	CRW1 R	CR 9960
	1.752	0.250	CRW1 V	CR 9982
	1.752	0.250	CRWA1 V	CR 9983
	1.752	0.250	CRW1 R	CR 9997
	1.752	0.250	CRWA1 R	CR 9998
	1.828	0.250	CRW1 V	CR 10046
	1.828	0.250	CRW1 P	CR 10047
	1.828	0.250	CRW1 R	CR 10049
	1.828	0.250	CRWA1 R	CR 10050
	1.851	0.250	CRW1 R	CR 10071
	1.874	0.250	CRW1 R	CR 10075
	1.938	0.250	CRW1 R	CR 10104
	1.983	0.250	CRWA1 V	CR 10111
	1.983	0.313	CRWA1 R	CR 10114
	2.000	0.250	CRW1 R	CR 10123
	2.000	0.250	CRWA1 R	CR 10124
	2.000	0.250	CRWA1 R	CR 10127
	2.000	0.250	CRW1 V	CR 10128
	2.000	0.250	CRWA1 V	CR 10129
	2.047	0.250	CRWA1 R	CR 10157
	2.062	0.250	CRW1 R	CR 10158
	2.250	0.250	CRW1 R	CR 10169
1.063	1.499	0.250	CRW1 R	CR 10515
	1.499	0.250	CRW1 V	CR 10518
	1.512	0.256	CRW1 P	CR 532866
	1.561	0.250	CRW1 R	CR 10581
	1.577	0.250	CRW1 R	CR 10583
	1.624	0.250	CRW1 R	CR 10598
	1.686	0.250	CRW1 R	CR 10632
	1.752	0.250	CRW1 R	CR 10653
	1.828	0.250	CRW1 R	CR 10681
	1.828	0.250	CRW1 V	CR 10682
	1.874	0.250	CRW1 R	CR 10700
	1.979	0.250	CRW1 R	CR 10728
	1.983	0.250	CRW1 R	CR 10733

Radial shaft seals – CRW1, CRWA1, CRWH1 and CRWA1 – inch dimensions
 d_1 1.063 – 1.250 in.

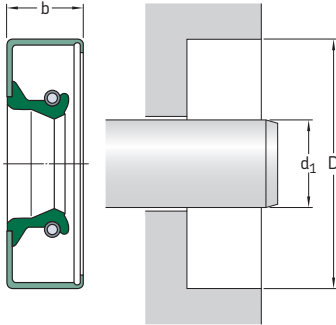

Please see pages 74 to 76 for housing bore requirements.

Dimensions Shaft	Bore	Nominal seal width b	Design and lip material	Designation
d_1	D	b		
in.			–	–
1.063	2.000	0.250	CRW1 R	CR 10740
cont.	2.062	0.250	CRW1 R	CR 10766
1.125	1.499	0.188	CRW1 V	CR 11059¹⁾
	1.499	0.188	CRW1 R	CR 11061¹⁾
	1.561	0.250	CRW1 P	CR 11066
	1.561	0.250	CRW1 R	CR 11067
	1.561	0.250	CRW1 V	CR 11071
	1.565	0.250	CRW1 R	CR 11082
	1.624	0.250	CRW1 P	CR 11111
	1.624	0.250	CRW1 R	CR 11123
	1.624	0.250	CRWA1 R	CR 11124
	1.624	0.250	CRW1 V	CR 11133
	1.624	0.250	CRWA1 V	CR 11134
	1.733	0.375	CRW1 R	CR 11137
	1.752	0.250	CRW1 R	CR 11138
	1.752	0.250	CRW1 V	CR 11144
	1.828	0.250	CRW1 R	CR 11170
	1.828	0.250	CRWA1 R	CR 11171
	1.828	0.250	CRW1 V	CR 11172
	1.828	0.250	CRWA1 V	CR 11175
	1.852	0.313	CRWH1 R	CR 11197
	1.852	0.313	CRWA1 R	CR 11200
	1.874	0.250	CRW1 V	CR 11207
	1.874	0.250	CRWA1 V	CR 11218
	1.874	0.250	CRW1 R	CR 11209
	1.874	0.250	CRWA1 R	CR 11223
	1.983	0.250	CRW1 R	CR 11299
	2.000	0.250	CRW1 R	CR 11340
	2.000	0.250	CRW1 V	CR 11344
	2.000	0.374	CRWA1 V	CR 12138
	2.000	0.375	CRWA1 R	CR 11343

¹⁾ Without SKF Bore Tite Coating

Dimensions Shaft	Bore	Nominal seal width b	Design and lip material	Designation
d ₁	D			
in.			–	–
1.125	2.047	0.313	CRWA1 R	CR 11353
cont.	2.062	0.250	CRWA1 V	CR 11368
	2.062	0.313	CRW1 R	CR 11366
	2.125	0.313	CRW1 R	CR 11372
	2.125	0.313	CRW1 V	CR 11373
	2.250	0.250	CRW1 R	CR 11378
	2.441	0.250	CRW1 R	CR 11392
1.126	1.575	0.236	CRWA1 R	CR 11086
1.156	1.686	0.250	CRWA1 R	CR 11518
	1.752	0.250	CRWA1 R	CR 11514
	1.874	0.250	CRW1 R	CR 11524
	1.875	0.375	CRWA1 R	CR 11536¹⁾
	2.000	0.250	CRW1 R	CR 11544
	2.000	0.250	CRWA1 R	CR 11545
	2.000	0.250	CRW1 V	CR 11550
	2.062	0.313	CRW1 R	CR 11557
1.175	2.031	0.500	CRW1 R	CR 11553
1.178	2.073	0.335	CRW1 S	CR 11650
1.188	1.561	0.313	CRW1 V	CR 11710¹⁾
	1.686	0.250	CRW1 P	CR 11728
	1.687	0.250	CRW1 R	CR 11730
	1.752	0.250	CRW1 R	CR 11734
	1.752	0.250	CRW1 V	CR 11736
	1.828	0.375	CRW1 R	CR 11740
	1.875	0.250	CRW1 P	CR 11763
	1.875	0.375	CRW1 R	CR 11585
	1.983	0.250	CRW1 R	CR 11776
	1.983	0.250	CRWA1 R	CR 11777
	2.000	0.250	CRW1 R	CR 11800
	2.000	0.250	CRWA1 R	CR 11801
	2.000	0.250	CRW1 V	CR 11806
	2.062	0.250	CRW1 R	CR 11878
	2.062	0.250	CRW1 P	CR 11879
	2.125	0.313	CRW1 R	CR 11907
	2.165	0.250	CRW1 R	CR 11911
	2.250	0.250	CRW1 R	CR 11914
	2.437	0.250	CRW1 R	CR 11923
	2.441	0.250	CRW1 R	CR 11930
1.190	2.125	0.313	CRWHA1 R	CR 11908
1.234	2.250	0.250	CRW1 R	CR 12590
1.250	1.625	0.188	CRW1 R	CR 12329
	1.687	0.250	CRW1 V	CR 12335
	1.687	0.250	CRW1 R	CR 12336
	1.687	0.250	CRWA1 V	CR 12337
	1.687	0.313	CRWA1 R	CR 12350

¹⁾ Without SKF Bore Tite Coating

Radial shaft seals – CRW1, CRWA1, CRWH1 and CRWA1 – inch dimensions
 d_1 1.250 – 1.375 in.

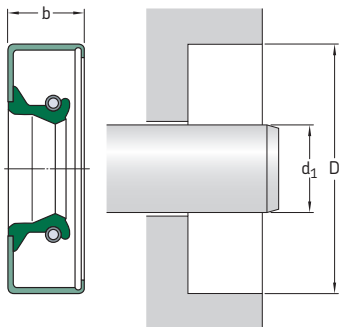

Please see **pages 74 to 76** for housing bore requirements.

Dimensions Shaft	Bore	Nominal seal width b	Design and lip material	Designation
d_1	D			
in.			–	–
1.250	1.752	0.250	CRW1 V	CR 12340
cont.	1.752	0.250	CRWA1 V	CR 12343
	1.752	0.250	CRW1 R	CR 12363
	1.752	0.250	CRWA1 R	CR 12364
	1.874	0.250	CRW1 P	CR 12382
	1.874	0.250	CRWA1 V	CR 12383
	1.874	0.250	CRW1 R	CR 12384
	1.874	0.250	CRWA1 R	CR 12386
	1.938	0.250	CRW1 R	CR 12391
	1.955	0.250	CRWA1 R	CR 12396
	1.983	0.250	CRW1 R	CR 12427
	1.983	0.250	CRWA1 R	CR 12428
	1.983	0.250	CRW1 V	CR 12432
	2.000	0.250	CRW1 V	CR 12445
	2.000	0.250	CRWA1 V	CR 12446
	2.000	0.250	CRW1 R	CR 12456
	2.000	0.250	CRWA1 R	CR 12458
	2.000	0.438	CRW1 P	CR 12483
	2.062	0.250	CRWA1 V	CR 12531
	2.062	0.433	CRWA1 V	CR 12533
	2.062	0.438	CRWH1 R	CR 12530
	2.125	0.250	CRW1 V	CR 12544
	2.125	0.250	CRW1 R	CR 12545
	2.125	0.250	CRWA1 R	CR 12551
	2.250	0.250	CRW1 R	CR 12577
	2.327	0.500	CRW1 R	CR 12610
	2.374	0.313	CRW1 R	CR 12613
	2.374	0.313	CRWA1 R	CR 12614
	2.374	0.315	CRW1 V	CR 12612
	2.437	0.250	CRW1 R	CR 12621
	2.441	0.250	CRW1 R	CR 12631
	2.500	0.310	CRW1 V	CR 12638
	2.502	0.313	CRW1 R	CR 12637

Dimensions Shaft	Bore	Nominal seal width b	Design and lip material	Designation
d ₁	D			
in.			–	–
1.301	2.046	0.492	CRWA1 R	CR 12907
1.313	1.828	0.375	CRW1 P	CR 13021
	2.062	0.313	CRW1 R	CR 13050
	2.062	0.313	CRWA1 R	CR 13052
	2.062	0.313	CRW1 V	CR 13054
	2.125	0.313	CRW1 R	CR 13092
	2.250	0.313	CRW1 R	CR 13112
	2.282	0.250	CRWA1 R	CR 13157
1.328	2.031	0.313	CRW1 R	CR 13415¹⁾
	2.061	0.313	CRW1 R	CR 13350
	2.227	0.313	CRW1 R	CR 13418
1.344	2.106	0.313	CRW1 R	CR 13421
	2.125	0.313	CRW1 R	CR 13437
1.365	1.956	0.438	CRW1 R	CR 13985
	2.081	0.313	CRW1 R	CR 13598
	2.261	0.313	CRW1 R	CR 13700
1.375	1.750	0.250	CRW1 R	CR 13514
	1.828	0.250	CRWA1 V	CR 13510
	1.828	0.313	CRW1 R	CR 13537
	1.835	0.250	CRW1 R	CR 13536
	1.873	0.313	CRW1 V	CR 13511
	1.874	0.250	CRW1 P	CR 13512
	1.874	0.250	CRW1 R	CR 13534
	1.874	0.250	CRW1 V	CR 13538
	1.874	0.313	CRWA1 R	CR 13535
	1.938	0.250	CRWA1 R	CR 13552
	1.955	0.433	CRWA1 P	CR 13527
	1.983	0.313	CRW1 P	CR 13557
	2.000	0.313	CRWA1 P	CR 13562
	2.000	0.313	CRW1 R	CR 13568
	2.000	0.313	CRWA1 R	CR 13569
	2.000	0.313	CRWH1 R	CR 13571
	2.000	0.313	CRW1 V	CR 13579
	2.000	0.313	CRWA1 V	CR 13581
	2.062	0.313	CRW1 V	CR 13582
	2.062	0.313	CRW1 R	CR 13585¹⁾
	2.062	0.313	CRWA1 P	CR 13588
	2.062	0.315	CRWA1 V	CR 13607
	2.106	0.313	CRWA1 R	CR 13602¹⁾
	2.106	0.313	CRW1 P	CR 13614
	2.125	0.313	CRW1 R	CR 13649
	2.125	0.313	CRWA1 R	CR 13650
	2.125	0.313	CRWA1 V	CR 13661
	2.125	0.313	CRW1 V	CR 13663
	2.250	0.250	CRWA1 R	CR 13698
	2.250	0.313	CRW1 R	CR 13671
	2.250	0.313	CRWA1 R	CR 13676
	2.250	0.313	CRW1 V	CR 13688
	2.250	0.313	CRWA1 V	CR 13691
	2.250	0.313	CRW1 P	CR 13869

¹⁾ Without SKF Bore Tite Coating

Radial shaft seals – CRW1, CRWA1, CRWH1 and CRWA1 – inch dimensions
d₁ 1.375 – 1.500 in.

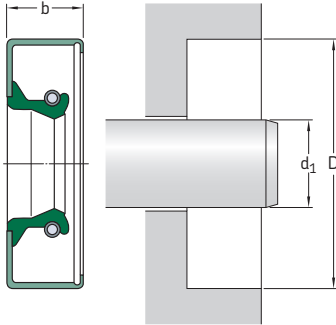

Please see **pages 74 to 76** for housing bore requirements.

Dimensions Shaft	Bore	Nominal seal width b	Design and lip material	Designation
d ₁	D			
in.			–	–
1.375	2.374	0.313	CRW1 V	CR 13734
cont.	2.374	0.313	CRW1 R	CR 13738
	2.374	0.313	CRWA1 R	CR 13739
	2.437	0.250	CRW1 R	CR 13797
	2.441	0.313	CRW1 R	CR 13810
	2.441	0.313	CRWA1 R	CR 13812
	2.502	0.313	CRW1 R	CR 13865
	2.502	0.313	CRW1 V	CR 13867
	2.502	0.374	CRWA1 V	CR 13856
	2.562	0.375	CRW1 R	CR 13875
	2.562	0.375	CRWA1 R	CR 13876
	2.562	0.375	CRWA1 V	CR 13878
	2.623	0.313	CRWA1 V	CR 13882
	2.686	0.500	CRW1 R	CR 13892
	2.716	0.313	CRW1 R	CR 13900
	2.812	0.375	CRWA1 R	CR 13912
	2.835	0.313	CRWA1 R	CR 13918
	2.835	0.313	CRW1 R	CR 13920
	2.835	0.313	CRWA1 P	CR 13925
	2.875	0.313	CRWA1 P	CR 13929
1.378	2.835	0.313	CRWA1 V	CR 13926
1.417	2.616	0.313	CRW1 R	CR 14092
1.438	2.062	0.313	CRW1 V	CR 14212¹⁾
	2.062	0.313	CRWA1 R	CR 14214
	2.125	0.313	CRW1 R	CR 14223
	2.125	0.313	CRWA1 V	CR 14225
	2.250	0.313	CRWA1 R	CR 14247
	2.250	0.313	CRWA1 V	CR 14259
	2.250	0.313	CRW1 V	CR 14260
	2.250	0.313	CRW1 R	CR 14262

¹⁾ Without SKF Bore Tite Coating

Dimensions Shaft	Bore	Nominal seal width b	Design and lip material	Designation
d ₁	D			
in.			–	–
1.438	2.374	0.313	CRW1 R	CR 14282
cont.	2.374	0.313	CRWA1 R	CR 14283
	2.437	0.313	CRW1 R	CR 14363
	2.502	0.313	CRW1 R	CR 14383
	2.623	0.313	CRW1 R	CR 14404
	2.686	0.313	CRW1 R	CR 14423
	2.750	0.313	CRW1 R	CR 14458
1.484	2.254	0.313	CRW1 R	CR 14907
1.494	2.060	0.270	CRW1 R	CR 14789
1.496	2.165	0.315	CRWA1 R	CR 550250
1.500	1.874	0.250	CRW1 R	CR 14807 ¹⁾
	1.918	0.250	CRW1 V	CR 14809 ¹⁾
	1.983	0.250	CRW1 V	CR 14821
	1.983	0.250	CRWA1 R	CR 14824
	1.983	0.313	CRW1 R	CR 14832
	2.000	0.313	CRWA1 R	CR 14846
	2.000	0.313	CRW1 R	CR 14855
	2.000	0.313	CRW1 V	CR 14861
	2.048	0.313	CRWA1 R	CR 14858
	2.062	0.313	CRW1 R	CR 14864
	2.062	0.313	CRW1 V	CR 14867
	2.125	0.313	CRW1 R	CR 14875
	2.125	0.313	CRWA1 R	CR 14876
	2.125	0.313	CRW1 V	CR 14886
	2.125	0.313	CRWA1 V	CR 14887
	2.222	0.313	CRW1 R	CR 14903
	2.250	0.313	CRW1 S	CR 14935
	2.250	0.313	CRW1 R	CR 14938
	2.250	0.313	CRWA1 R	CR 14939
	2.250	0.313	CRW1 V	CR 14940
	2.250	0.313	CRWA1 V	CR 14942
	2.260	0.406	CRW1 R	CR 14968
	2.374	0.313	CRW1 V	CR 14992
	2.374	0.313	CRWA1 V	CR 14994
	2.374	0.313	CRW1 R	CR 15004
	2.374	0.313	CRWA1 R	CR 15005
	2.374	0.500	CRWH1 R	CR 15039
	2.377	0.453	CRWA1 R	CR 15041
	2.437	0.313	CRW1 R	CR 15076
	2.441	0.313	CRW1 R	CR 15092 ¹⁾
	2.441	0.313	CRWA1 R	CR 15093
	2.441	0.313	CRW1 V	CR 15097
	2.502	0.313	CRW1 V	CR 15138
	2.502	0.313	CRW1 R	CR 15141
	2.502	0.313	CRWA1 R	CR 15142
	2.561	0.313	CRW1 R	CR 15176
	2.623	0.313	CRW1 R	CR 15194
	2.686	0.500	CRW1 R	CR 15207

¹⁾ Without SKF Bore Tite Coating

Radial shaft seals – CRW1, CRWA1, CRWH1 and CRWA1 – inch dimensions
 d_1 1.500 – 1.645 in.

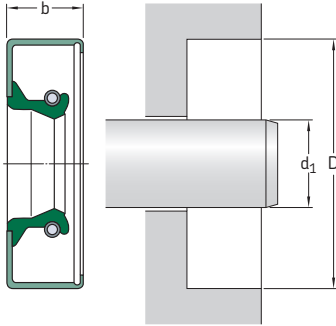

Please see **pages 74 to 76** for housing bore requirements.

Dimensions Shaft	Bore	Nominal seal width b	Design and lip material	Designation
d_1	D			
in.			–	–
1.500	2.716	0.438	CRW1 R	CR 15204
cont.	2.750	0.313	CRW1 R	CR 15214
	2.758	0.313	CRW1 R	CR 15230
	2.835	0.313	CRW1 R	CR 15234
	2.875	0.313	CRW1 R	CR 15235
1.552	2.502	0.500	CRWA1 R	CR 15450
	2.686	0.500	CRW1 R	CR 15460
	2.750	0.500	CRWHA1 P	CR 15462
1.563	2.062	0.250	CRW1 V	CR 15506
	2.062	0.250	CRW1 R	CR 15508
	2.125	0.313	CRW1 R	CR 15517¹⁾
	2.125	0.313	CRWA1 P	CR 15518
	2.250	0.313	CRW1 R	CR 15522
	2.374	0.313	CRW1 P	CR 15540¹⁾
	2.374	0.313	CRW1 R	CR 15542
	2.374	0.313	CRWA1 R	CR 15543
	2.374	0.313	CRWA1 V	CR 15549
	2.437	0.313	CRW1 R	CR 15592¹⁾
	2.441	0.500	CRWA1 R	CR 15620
	2.465	0.374	CRWA1 P	CR 15624
	2.502	0.313	CRWA1 R	CR 15635
	2.502	0.313	CRW1 R	CR 15655
	2.502	0.313	CRW1 V	CR 15656
	2.561	0.313	CRW1 R	CR 15677
	2.623	0.313	CRW1 R	CR 15699
	2.686	0.313	CRW1 R	CR 15707
	2.750	0.500	CRWH1 R	CR 15761
	2.875	0.313	CRW1 R	CR 15773
	2.875	0.313	CRWA1 P	CR 15779

¹⁾ Without SKF Bore Tite Coating

Dimensions Shaft	Bore	Nominal seal width b	Design and lip material	Designation
d ₁	D			
in.			–	–
1.578	2.082 2.408	0.250 0.313	CRW1 R CRWHA1 R	CR 15510 CR 15557
1.594	2.125 2.437 2.437	0.313 0.313 0.313	CRW1 P CRW1 P CRW1 R	CR 15915 CR 15940 CR 15955
	2.502 2.623 2.758	0.313 0.313 0.313	CRW1 R CRW1 R CRW1 R	CR 15960 CR 15968 CR 15975
1.618	2.531	0.438	CRWA1 R	CR 16449
1.625	2.000 2.000	0.250 0.250	CRW1 V CRW1 R	CR 16039 CR 16046 ¹⁾
	2.116 2.125 2.125	0.313 0.250 0.250	CRWA1 R CRW1 V CRW1 R	CR 16047 CR 16048 CR 16054
	2.248 2.250 2.250 2.250 2.282	0.313 0.313 0.313 0.375 0.313	CRWA1 R CRW1 R CRW1 V CRW1 P CRW1 R	CR 16062 CR 16061 CR 16078 ¹⁾ CR 16049 CR 16083
	2.374 2.374 2.374	0.250 0.313 0.313	CRW1 R CRWH1 R CRW1 V	CR 16094 ¹⁾ CR 16072 CR 16077
	2.374 2.374 2.374 2.374	0.313 0.313 0.313 0.500	CRW1 R CRWA1 R CRWA1 P CRWH1 R	CR 16084 CR 16085 CR 16091 ¹⁾ CR 16079
	2.437 2.437 2.437 2.437	0.313 0.313 0.313 0.313	CRW1 R CRWA1 R CRW1 V CRWA1 V	CR 16117 CR 16128 CR 16119 CR 16120
	2.441 2.441	0.313 0.313	CRW1 R CRWA1 R	CR 16180 CR 16201
	2.502 2.502 2.502	0.313 0.313 0.313	CRWA1 V CRW1 R CRWA1 R	CR 16243 CR 16245 CR 16246
	2.502 2.502 2.502 2.562	0.313 0.374 0.375 0.313	CRWA1 P CRWHA1 V CRWHA1 R CRWA1 V	CR 16247 ¹⁾ CR 16257 CR 16254 CR 16290
	2.623 2.623 2.623 2.686 2.686	0.313 0.313 0.313 0.313 0.313	CRW1 R CRWA1 R CRW1 V CRW1 R CRW1 V	CR 16314 CR 16315 CR 16316 CR 16337 CR 16338
	2.750 2.750 2.758	0.250 0.313 0.313	CRW1 R CRWH1 R CRW1 R	CR 16364 CR 16368 CR 16374
	2.875 3.000	0.313 0.313	CRW1 R CRWH1 R	CR 16406 CR 16422
1.645	2.656	0.313	CRWA1 P	CR 16500

¹⁾ Without SKF Bore Tite Coating

Radial shaft seals – CRW1, CRWA1, CRWH1 and CRWHA1 – inch dimensions

d_1 1.656 – 1.813 in.

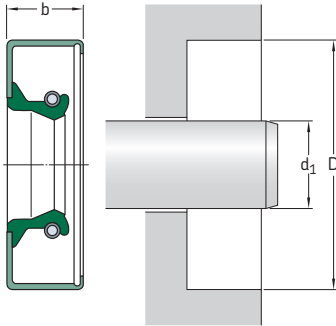

Please see pages 74 to 76 for housing bore requirements.

Dimensions Shaft	Bore	Nominal seal width b	Design and lip material	Designation
d_1	D	b		
in.			–	–
1.656	2.623 2.686	0.375 0.313	CRWA1 P CRW1 R	CR 16545 CR 16556
1.688	2.279 2.328	0.500 0.313	CRWH1 R CRWA1 R	CR 16650 CR 16657
	2.437 2.437 2.437 2.437	0.250 0.313 0.313 0.469	CRW1 S CRW1 R CRWA1 R CRW1 S	CR 16692 CR 16679 CR 16680 CR 16696
	2.502 2.623 2.623 2.623 2.686	0.313 0.313 0.500 0.500 0.313	CRW1 R CRWA1 R CRW1 R CRWA1 V CRW1 R	CR 16719 CR 16814 CR 16816 CR 16817 CR 16842
	2.716 2.750 2.750 2.875	0.313 0.313 0.375 0.313	CRW1 R CRW1 R CRWA1 R CRW1 R	CR 16854 CR 16900¹⁾ CR 16903 CR 16999
	3.061 3.125	0.375 0.375	CRW1 R CRWA1 R	CR 17035 CR 17038
1.704	3.034	0.500	CRWA1 R	CR 17100
1.719	2.561	0.315	CRWA1 R	CR 17144
1.750	2.250 2.250	0.313 0.313	CRW1 R CRW1 V	CR 17231 CR 17234
	2.374 2.374 2.374	0.313 0.313 0.313	CRWA1 V CRW1 R CRWA1 R	CR 17261 CR 17270 CR 17271
	2.411 2.437 2.437	0.375 0.313 0.313	CRW1 P CRW1 R CRW1 R	CR 17280 CR 17283 CR 17284

¹⁾ Without SKF Bore Tite Coating

Dimensions Shaft	Bore	Nominal seal width b	Design and lip material	Designation
d ₁	D			
in.			-	-
1.750	2.437	0.313	CRWA1 R	CR 17285
cont.	2.437	0.313	CRW1 V	CR 17292
	2.437	0.313	CRWA1 V	CR 17293
	2.441	0.313	CRW1 R	CR 17315
	2.441	0.313	CRWA1 R	CR 550154
	2.441	0.375	CRWA1 V	CR 17320
	2.502	0.313	CRW1 V	CR 17379
	2.502	0.313	CRWA1 V	CR 17381
	2.502	0.313	CRW1 R	CR 17386
	2.502	0.313	CRWA1 R	CR 17387
	2.502	0.375	CRWHA1 V	CR 17395
	2.502	0.375	CRW1 S	CR 17399
	2.561	0.313	CRW1 R	CR 17404
	2.565	0.313	CRWA1 R	CR 17413
	2.623	0.313	CRW1 R	CR 17442
	2.623	0.313	CRWA1 R	CR 17443
	2.623	0.313	CRW1 S	CR 17444
	2.623	0.313	CRWA1 V	CR 17448
	2.623	0.375	CRWH1 R	CR 17456
	2.686	0.313	CRW1 R	CR 17484¹⁾
	2.717	0.438	CRWA1 R	CR 17607
	2.750	0.313	CRWA1 R	CR 17523
	2.750	0.313	CRW1 R	CR 17557
	2.750	0.313	CRW1 V	CR 17558
	2.758	0.313	CRW1 R	CR 17605
	2.810	0.313	CRWA1 R	CR 17624¹⁾
	2.810	0.313	CRWA1 V	CR 17627
	2.875	0.313	CRW1 R	CR 17653
	2.875	0.313	CRW1 V	CR 17657
	2.875	0.375	CRWHA1 R	CR 17645
	2.981	0.438	CRWHA1 R	CR 17675¹⁾
	2.997	0.313	CRWHA1 R	CR 17678
	2.997	0.313	CRW1 R	CR 17695
	3.000	0.313	CRWA1 R	CR 17699
	3.000	0.313	CRW1 R	CR 17707
	3.000	0.313	CRW1 V	CR 17709
	3.061	0.313	CRW1 R	CR 17716
	3.061	0.375	CRWA1 R	CR 17718
	3.189	0.313	CRW1 R	CR 17746
	3.543	0.438	CRW1 R	CR 17756
	3.625	0.438	CRW1 R	CR 17761
1.768	2.363	0.313	CRWHA1 V	CR 17780
1.781	2.252	0.313	CRWA1 R	CR 17806
	2.502	0.313	CRWH1 R	CR 17810
	2.502	0.313	CRWH1 V	CR 17811
	2.623	0.313	CRW1 R	CR 17821
	2.686	0.313	CRW1 R	CR 17832¹⁾
1.812	2.623	0.374	CRWA1 V	CR 17949
1.813	2.279	0.313	CRW1 R	CR 18025
	2.437	0.313	CRW1 R	CR 18039
	2.562	0.313	CRWA1 V	CR 18049

¹⁾ Without SKF Bore Tite Coating

Radial shaft seals – CRW1, CRWA1, CRWH1 and CRWA1 – inch dimensions

d_1 **1.813 – 1.938 in.**

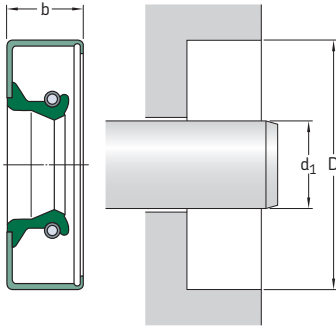

Please see **pages 74 to 76** for housing bore requirements.

Dimensions Shaft	Bore	Nominal seal width b	Design and lip material	Designation
d_1	D			
in.			–	–
1.813	2.623	0.313	CRW1 R	CR 18104
cont.	2.686	0.313	CRWA1 P	CR 18114
	2.750	0.313	CRW1 R	CR 18159
	2.875	0.313	CRW1 R	CR 18242
	3.000	0.375	CRWA1 P	CR 18264
1.844	2.623	0.313	CRW1 R	CR 18425
	2.750	0.313	CRW1 P	CR 18444
1.868	2.518	0.315	CRWA1 P	CR 18492
1.875	2.398	0.250	CRW1 R	CR 18549
	2.471	0.313	CRWA1 R	CR 18545
	2.500	0.313	CRW1 P	CR 18555
	2.502	0.313	CRW1 R	CR 18565
	2.562	0.313	CRWA1 V	CR 18546
	2.562	0.313	CRW1 P	CR 18562
	2.623	0.313	CRW1 R	CR 18580
	2.623	0.313	CRWA1 R	CR 18581
	2.623	0.313	CRW1 V	CR 18582
	2.623	0.313	CRWA1 V	CR 18584
	2.623	0.374	CRW1 S	CR 18592
	2.686	0.313	CRW1 R	CR 18626
	2.750	0.313	CRW1 V	CR 18652
	2.750	0.313	CRW1 R	CR 18657
	2.750	0.313	CRWA1 R	CR 18658
	2.750	0.313	CRW1 P	CR 18666
	2.758	0.313	CRW1 P	CR 18671
	2.758	0.313	CRW1 S	CR 18679
	2.782	0.438	CRWH1 R	CR 18693
	2.782	0.438	CRWA1 R	CR 18695
	2.875	0.313	CRW1 V	CR 18732
	2.875	0.313	CRW1 R	CR 18733
	2.875	0.313	CRWA1 R	CR 18734

Dimensions Shaft	Bore	Nominal seal width b	Design and lip material	Designation
d ₁	D			
in.			–	–
1.875	2.875	0.313	CRWA1 V	CR 18737
cont.	2.997	0.313	CRW1 R	CR 18785
	3.000	0.313	CRW1 R	CR 18817
	3.000	0.313	CRW1 V	CR 18818
	3.061	0.313	CRWA1 R	CR 18872
	3.105	0.500	CRWA1 R	CR 18880
	3.189	0.469	CRWH1 R	CR 18899
	3.249	0.484	CRWA1 R	CR 18922
	3.371	0.438	CRWH1 R	CR 18916
	3.496	0.438	CRWA1 R	CR 18924
	3.500	0.438	CRW1 R	CR 18926
1.893	2.434	0.250	CRW1 R	CR 19000¹⁾
1.906	2.752	0.375	CRWA1 P	CR 19017
1.915	2.533	0.250	CRW1 R	CR 19010
1.938	2.412	0.313	CRW1 R	CR 19215
	2.437	0.250	CRW1 R	CR 19210
	2.437	0.250	CRW1 R	CR 19212
	2.502	0.375	CRWA1 R	CR 19220
	2.563	0.313	CRW1 R	CR 19211
	2.623	0.313	CRW1 R	CR 19226
	2.623	0.313	CRWA1 V	CR 19227
	2.623	0.313	CRWA1 R	CR 19229
	2.686	0.300	CRW1 P	CR 19244
	2.686	0.313	CRWA1 P	CR 19234
	2.686	0.313	CRW1 R	CR 19236
	2.686	0.313	CRWA1 R	CR 19237
	2.686	0.313	CRWA1 V	CR 19243
	2.686	0.375	CRW1 S	CR 19240
	2.750	0.313	CRW1 R	CR 19264
	2.750	0.313	CRW1 V	CR 19267
	2.875	0.313	CRW1 R	CR 19300
	2.875	0.313	CRWA1 R	CR 19301
	2.875	0.313	CRWH1 V	CR 19304
	2.884	0.313	CRWA1 P	CR 19310
	2.997	0.313	CRW1 R	CR 19350
	3.000	0.313	CRW1 R	CR 19359
	3.000	0.313	CRWA1 R	CR 19360¹⁾
	3.000	0.313	CRWA1 V	CR 19368
	3.061	0.313	CRW1 R	CR 19380
	3.062	0.500	CRW1 S	CR 19438
	3.125	0.500	CRW1 R	CR 19400
	3.189	0.313	CRW1 R	CR 19407
	3.251	0.313	CRWA1 V	CR 19433
	3.251	0.313	CRW1 R	CR 19434
	3.350	0.469	CRWHA1 R	CR 19445
	3.543	0.313	CRW1 R	CR 19449

¹⁾ Without SKF Bore Tite Coating

Radial shaft seals – CRW1, CRWA1, CRWH1 and CRWHA1 – inch dimensions

d_1 1.969 – 2.125 in.

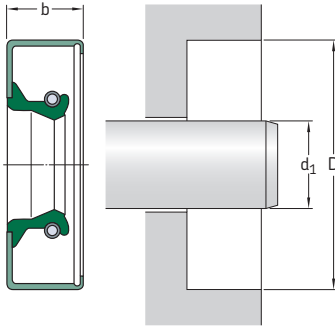

Please see pages 74 to 76 for housing bore requirements.

Dimensions Shaft	Bore	Nominal seal width	Design and lip material	Designation
d_1	D	b		
in.			–	–
1.969	2.623	0.313	CRWA1 R	CR 19607
2.000	2.500	0.438	CRW1 S	CR 19739
	2.502	0.313	CRW1 P	CR 19745
	2.623	0.313	CRW1 R	CR 19760
	2.623	0.313	CRWA1 R	CR 19762
	2.623	0.313	CRWA1 V	CR 19777
	2.623	0.313	CRWA1 V	CR 19782
	2.686	0.375	CRW1 R	CR 19778
	2.716	0.375	CRW1 R	CR 19785
	2.716	0.375	CRWA1 R	CR 19786
	2.746	0.375	CRW1 S	CR 19807
	2.750	0.313	CRW1 V	CR 19823
	2.750	0.313	CRW1 R	CR 19831
	2.750	0.313	CRWA1 R	CR 19832
	2.750	0.313	CRWA1 V	CR 19839
	2.750	0.313	CRW1 V	CR 19840
	2.835	0.469	CRWH1 R	CR 19848
	2.875	0.313	CRW1 V	CR 19884
	2.875	0.313	CRW1 R	CR 19886
	2.875	0.313	CRWA1 R	CR 19887
	2.875	0.375	CRWHA1 R	CR 19896
	2.875	0.500	CRWH1 R	CR 19900
	2.880	0.375	CRWA1 R	CR 19922
	2.880	0.375	CRWA1 P	CR 19923
	2.997	0.375	CRWH1 R	CR 19969
	2.997	0.375	CRWHA1 R	CR 19970
	2.997	0.375	CRWH1 V	CR 19979
	3.000	0.313	CRW1 R	CR 19992
	3.000	0.313	CRWA1 R	CR 19993
	3.000	0.313	CRWA1 V	CR 19995

Dimensions Shaft	Bore	Nominal seal width b	Design and lip material	Designation
d ₁	D			
in.			–	–
2.000	3.000	0.375	CRWH1 V	CR 20002
cont.	3.000	0.375	CRWH1 R	CR 20004
	3.000	0.375	CRWA1 R	CR 20005
	3.061	0.375	CRW1 R	CR 20045
	3.061	0.500	CRWH1 R	CR 20053
	3.061	0.500	CRWA1 R	CR 20054
	3.125	0.375	CRW1 R	CR 20070
	3.150	0.375	CRW1 R	CR 20079
	3.189	0.469	CRWH1 R	CR 20098
	3.189	0.469	CRWA1 R	CR 20100
	3.251	0.438	CRWH1 R	CR 20109
	3.371	0.438	CRW1 V	CR 20122
	3.371	0.438	CRWH1 R	CR 20124
	3.371	0.438	CRWA1 R	CR 20125
	3.371	0.438	CRWH1 V	CR 20127 ¹⁾
	3.543	0.438	CRWH1 R	CR 20140
	3.623	0.438	CRWH1 R	CR 20144
	4.003	0.438	CRWH1 R	CR 20158
2.047	2.561	0.315	CRW1 R	CR 20420
2.063	2.561	0.313	CRW1 V	CR 20520
	2.750	0.313	CRWH1 R	CR 20530 ¹⁾
	2.842	0.438	CRWH1 R	CR 20538
	2.875	0.438	CRWH1 R	CR 20554
	2.997	0.438	CRWH1 R	CR 20586
	3.000	0.375	CRW1 R	CR 20594
	3.000	0.375	CRWA1 V	CR 20599
	3.061	0.313	CRWH1 R	CR 20643
	3.125	0.375	CRW1 R	CR 20659
	3.189	0.375	CRW1 R	CR 20702
	3.251	0.438	CRWA1 R	CR 20747
	3.251	0.438	CRWH1 R	CR 20749
2.125	2.750	0.375	CRW1 V	CR 21063 ¹⁾
	2.750	0.500	CRWA1 R	CR 21061
	2.763	0.250	CRW1 R	CR 21069
	2.875	0.375	CRW1 S	CR 21103
	2.875	0.438	CRW1 V	CR 21091
	2.875	0.438	CRW1 R	CR 21098
	2.875	0.438	CRWA1 R	CR 21100
	2.875	0.438	CRWA1 R	CR 21108
	2.997	0.438	CRWH1 R	CR 21134
	2.997	0.438	CRWA1 R	CR 21136
	3.000	0.313	CRWA1 V	CR 21167
	3.000	0.375	CRW1 R	CR 21163
	3.000	0.375	CRWA1 R	CR 21164
	3.000	0.438	CRWH1 V	CR 21171
	3.000	0.438	CRWH1 R	CR 21172
	3.000	0.438	CRWA1 R	CR 21173

¹⁾ Without SKF Bore Tite Coating

Radial shaft seals – CRW1, CRWA1, CRWH1 and CRWA1 – inch dimensions
 d_1 2.125 – 2.328 in.

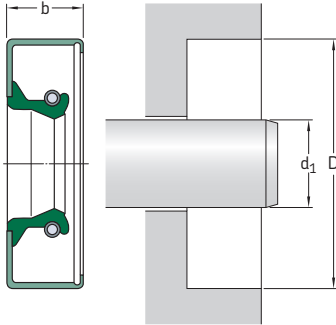

Please see **pages 74 to 76** for housing bore requirements.

Dimensions Shaft	Bore	Nominal seal width b	Design and lip material	Designation
d_1	D	b		
in.			–	–
2.125	3.061	0.438	CRWH1 V	CR 21203
cont.	3.061	0.500	CRW1 R	CR 21210
	3.061	0.500	CRWA1 R	CR 21211¹⁾
	3.061	0.500	CRWA1 R	CR 21213
	3.125	0.438	CRWH1 R	CR 21234
	3.125	0.438	CRWA1 P	CR 21245
	3.189	0.375	CRWA1 R	CR 21267
	3.189	0.375	CRWA1 V	CR 21269
	3.189	0.469	CRWA1 S	CR 21270
	3.251	0.438	CRWH1 R	CR 21302
	3.350	0.438	CRWH1 R	CR 21336
	3.371	0.375	CRWA1 R	CR 21352
	3.371	0.438	CRWH1 R	CR 21353
	3.543	0.438	CRWH1 R	CR 21358
2.188	2.875	0.438	CRWH1 R	CR 21736
	2.997	0.438	CRWH1 R	CR 21749
	3.000	0.375	CRWA1 R	CR 21759
	3.000	0.375	CRWA1 V	CR 21763
	3.000	0.500	CRWH1 R	CR 21764
	3.061	0.500	CRWH1 R	CR 21775
	3.251	0.438	CRWH1 R	CR 21840
	3.350	0.438	CRWH1 R	CR 21890
	3.371	0.438	CRWH1 R	CR 21910
2.250	2.875	0.313	CRWA1 R	CR 22328
	2.891	0.563	CRWA1 R	CR 22319
	2.997	0.438	CRWH1 R	CR 22338
	2.997	0.438	CRWA1 R	CR 22340
	3.000	0.375	CRW1 R	CR 22353
	3.000	0.375	CRWA1 R	CR 22354
	3.000	0.375	CRWA1 V	CR 22361
	3.000	0.375	CRW1 V	CR 22363

¹⁾ Without SKF Bore Tite Coating

Dimensions Shaft	Bore	Nominal seal width b	Design and lip material	Designation
d ₁	D			
in.			–	–
2.250	3.000	0.438	CRWH1 R	CR 22358
cont.	3.000	0.438	CRWHA1 R	CR 22359
	3.000	0.438	CRWH1 V	CR 22367
	3.061	0.375	CRW1 R	CR 22382
	3.061	0.438	CRWH1 R	CR 22390
	3.061	0.438	CRWHA1 R	CR 22391
	3.061	0.438	CRWHA1 S	CR 22394
	3.125	0.375	CRWA1 R	CR 22400
	3.125	0.375	CRWA1 V	CR 22405
	3.125	0.500	CRWH1 R	CR 22407 ¹⁾
	3.189	0.438	CRW1 R	CR 22424
	3.189	0.438	CRWA1 P	CR 22425
	3.251	0.375	CRW1 R	CR 22440
	3.251	0.375	CRWA1 R	CR 22441
	3.251	0.438	CRWH1 R	CR 22446
	3.251	0.438	CRWHA1 R	CR 22448
	3.251	0.438	CRWH1 V	CR 22449
	3.350	0.375	CRW1 P	CR 22484
	3.350	0.438	CRWH1 R	CR 22492 ¹⁾
	3.350	0.438	CRWHA1 R	CR 22493
	3.350	0.438	CRWH1 V	CR 22495
	3.371	0.438	CRWHA1 R	CR 22532
	3.371	0.438	CRWH1 R	CR 22558
	3.371	0.438	CRWH1 V	CR 22561
	3.500	0.438	CRWHA1 R	CR 22582
	3.500	0.438	CRWH1 R	CR 22583
	3.500	0.438	CRWHA1 V	CR 22590
	3.565	0.438	CRWA1 R	CR 22610
	3.623	0.438	CRWH1 R	CR 22618
	3.623	0.438	CRWHA1 R	CR 22619
	3.751	0.438	CRWH1 R	CR 22626
	3.876	0.438	CRWH1 R	CR 22644
	4.003	0.438	CRWH1 R	CR 22647
2.313	2.997	0.375	CRW1 R	CR 23030
	3.000	0.438	CRWH1 V	CR 23040
	3.061	0.313	CRW1 R	CR 23046
	3.125	0.375	CRW1 R	CR 23061
	3.125	0.375	CRWA1 V	CR 23063
	3.251	0.438	CRWH1 R	CR 23093
	3.251	0.438	CRWHA1 V	CR 23099 ¹⁾
	3.350	0.438	CRWH1 R	CR 23152
	3.371	0.438	CRW1 R	CR 23167
	3.374	0.438	CRWHA1 R	CR 23169
	3.500	0.313	CRW1 R	CR 23184 ¹⁾
	3.751	0.500	CRW1 R	CR 23277
2.328	3.000	0.395	CRW1 P	CR 23300

¹⁾ Without SKF Bore Tite Coating

Radial shaft seals – CRW1, CRWA1, CRWH1 and CRWA1 – inch dimensions
 d_1 2.375 – 2.500 in.

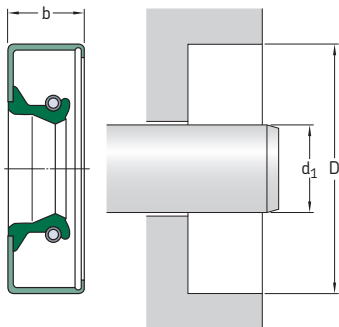

Please see pages 74 to 76 for housing bore requirements.

Dimensions Shaft	Bore	Nominal seal width b	Design and lip material	Designation
d_1	D	b		
in.			–	–
2.375	2.997	0.438	CRWH1 R	CR 23632
cont.	3.000	0.375	CRW1 V	CR 23641
	3.061	0.438	CRWH1 R	CR 23644
	3.061	0.438	CRWH1 P	CR 23645
	3.061	0.438	CRWH1 V	CR 23655
	3.125	0.375	CRW1 R	CR 23646
	3.125	0.438	CRWH1 R	CR 23652
	3.125	0.438	CRWHA1 R	CR 23654
	3.125	0.438	CRWHA1 V	CR 23656
	3.189	0.438	CRWH1 R	CR 23666
	3.251	0.438	CRWHA1 V	CR 23678
	3.251	0.453	CRW1 P	CR 23685
	3.350	0.375	CRW1 R	CR 23701
	3.350	0.375	CRWA1 R	CR 23702
	3.350	0.375	CRW1 P	CR 23703
	3.350	0.375	CRW1 S	CR 23706
	3.350	0.438	CRWH1 R	CR 23708
	3.350	0.438	CRWHA1 R	CR 23710
	3.371	0.438	CRWH1 R	CR 23742
	3.371	0.438	CRWH1 V	CR 23746
	3.481	0.438	CRWH1 R	CR 23755
	3.481	0.438	CRWHA1 R	CR 23756¹⁾
	3.500	0.375	CRWA1 P	CR 23770
	3.500	0.375	CRWH1 V	CR 23771
	3.500	0.375	CRWH1 R	CR 23779
	3.500	0.438	CRWHA1 R	CR 23782
	3.543	0.438	CRWH1 R	CR 23808
	3.543	0.438	CRWHA1 V	CR 23809
	3.601	0.438	CRW1 R	CR 23820
	3.623	0.438	CRWH1 R	CR 23839

¹⁾ Without SKF Bore Tite Coating

Dimensions Shaft	Bore	Nominal seal width b	Design and lip material	Designation	
d ₁	D				
in.			–	–	
2.375 cont.	3.623	0.438	CRWHA1 P	CR 23841	
	3.623	0.438	CRWHA1 V	CR 23843	
	3.876	0.438	CRWH1 R	CR 23844	
2.438	3.125	0.500	CRWH1 R	CR 24255	
	3.251	0.438	CRWH1 R	CR 24263	
	3.350	0.375	CRW1 R	CR 24286	
	3.350	0.375	CRWA1 R	CR 24287	
	3.371	0.438	CRWH1 R	CR 24320	
	3.481	0.438	CRWH1 R	CR 24340	
	3.500	0.438	CRWH1 R	CR 24370	
	3.500	0.438	CRWH1 V	CR 24372	
	3.543	0.438	CRWH1 R	CR 24445	
	2.500	3.189	0.438	CRWH1 R	CR 24881
		3.189	0.438	CRWH1 V	CR 24883
		3.245	0.438	CRWH1 R	CR 24889
3.251		0.375	CRW1 R	CR 24897	
3.251		0.375	CRWA1 R	CR 24898	
3.251		0.375	CRWA1 V	CR 24899	
3.251		0.438	CRWH1 R	CR 24910	
3.251		0.438	CRWHA1 R	CR 24911	
3.251		0.438	CRWH1 V	CR 24914	
3.251		0.438	CRWHA1 V	CR 24916	
3.251		0.500	CRW1 V	CR 24913	
3.350		0.438	CRWH1 R	CR 24931	
3.350		0.438	CRWHA1 R	CR 24932	
3.371		0.375	CRWHA1 R	CR 24934 ¹⁾	
3.371		0.438	CRWHA1 V	CR 24936	
3.371		0.438	CRWH1 R	CR 24954	
3.428		0.375	CRWA1 P	CR 24949	
3.428		0.375	CRWA1 R	CR 24951	
3.500		0.375	CRWA1 V	CR 24971	
3.500		0.438	CRW1 R	CR 24980	
3.500		0.438	CRWA1 R	CR 24982	
3.500		0.438	CRWH1 V	CR 24984	
3.500		0.438	CRWH1 R	CR 24986	
3.500		0.438	CRWHA1 R	CR 24988	
3.500		0.438	CRWH1 P	CR 24989	
3.500		0.438	CRWHA1 V	CR 24990	
3.502		0.406	CRW1 S	CR 25082	
3.543		0.438	CRWH1 R	CR 25043	
3.543	0.438	CRWHA1 P	CR 25065 ¹⁾		
3.544	0.433	CRWA1 V	CR 25037		
3.623	0.375	CRW1 R	CR 25074		
3.623	0.375	CRWA1 R	CR 25075		
3.623	0.375	CRWA1 V	CR 25076		
3.623	0.438	CRWH1 R	CR 25071 ¹⁾		
3.751	0.438	CRWH1 R	CR 25091 ¹⁾		
3.876	0.438	CRWH1 R	CR 25100		
3.876	0.469	CRWHA1 P	CR 25102		
4.003	0.375	CRWA1 R	CR 25108		
4.003	0.375	CRWA1 V	CR 25110		

¹⁾ Without SKF Bore Tite Coating

Radial shaft seals – CRW1, CRWA1, CRWH1 and CRWHA1 – inch dimensions
 d_1 2.563 – 2.750 in.

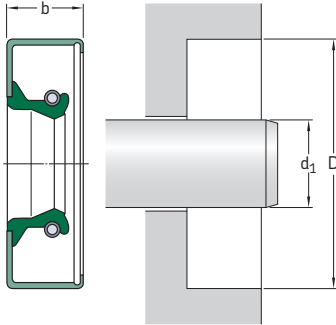

Please see **pages 74 to 76** for housing bore requirements.

Dimensions Shaft	Bore	Nominal seal width b	Design and lip material	Designation
d_1	D			
in.			–	–
2.563	3.481 3.500	0.500 0.438	CRWHA1 R CRWH1 R	CR 25561 CR 25577
	3.623 3.623	0.438 0.469	CRWH1 R CRWA1 P	CR 25641 CR 25661
	3.751 3.751 3.751	0.438 0.438 0.438	CRWH1 R CRWHA1 R CRWH1 V	CR 25713 CR 25714 CR 25725
	3.873 3.876	0.438 0.438	CRWHA1 R CRWH1 R	CR 25745¹⁾ CR 25748
2.598	3.481	0.438	CRWHA1 P	CR 25970
2.607	3.350	0.375	CRWH1 P	CR 25950
2.625	3.251 3.350 3.350 3.350 3.350	0.438 0.375 0.375 0.375 0.438	CRWH1 R CRW1 V CRW1 R CRWA1 R CRW1 R	CR 26110 CR 26122 CR 26123 CR 26124 CR 26128¹⁾
	3.371 3.374 3.481	0.438 0.438 0.438	CRWHA1 R CRWHA1 R CRWH1 R	CR 26153 CR 26141 CR 26163
	3.500 3.500 3.500 3.500	0.375 0.375 0.438 0.438	CRW1 V CRWA1 R CRWH1 R CRWHA1 R	CR 26177 CR 26186 CR 26189 CR 26190
	3.500 3.543	0.438 0.438	CRWA1 P CRWH1 R	CR 26191 CR 26194
	3.623 3.623 3.623	0.375 0.375 0.375	CRW1 V CRWA1 P CRW1 R	CR 26204 CR 26220 CR 26237

¹⁾ Without SKF Bore Tite Coating

Dimensions Shaft	Bore	Nominal seal width b	Design and lip material	Designation
d ₁	D			
in.			–	–
2.625 cont.	3.623 3.623 3.623 3.623	0.375 0.438 0.438 0.438	CRWA1 R CRWH1 V CRWH1 R CRWHA1 R	CR 26238 CR 26208 CR 26209 CR 26211
	3.751 3.751	0.375 0.438	CRWA1 R CRWH1 R	CR 26284 CR 26297
	3.751 3.751	0.438 0.438	CRWHA1 R CRWHA1 V	CR 26298 CR 26299
	3.876 3.936	0.438 0.438	CRWH1 R CRWH1 R	CR 26328 CR 26346
	4.003 4.003	0.375 0.438	CRWA1 R CRWH1 R	CR 26354 CR 26356
	4.370 4.438	0.438 0.438	CRWHA1 R CRWH1 R	CR 26359 CR 26368
2.688	3.751 3.876 4.003	0.438 0.438 0.469	CRWH1 R CRWH1 R CRWH1 R	CR 26761 CR 26921 CR 26975
2.750	3.481 3.500	0.438 0.375	CRW1 R CRW1 R	CR 27251 ¹⁾ CR 27268
	3.500 3.500 3.500 3.538	0.375 0.375 0.438 0.438	CRWA1 R CRWA1 V CRWH1 R CRWH1 R	CR 27269 CR 27272 CR 27280 CR 27284
	3.543 3.543 3.543	0.438 0.438 0.438	CRWH1 P CRWH1 V CRWHA1 P	CR 27292 CR 27293 CR 27295
	3.623 3.623	0.438 0.438	CRWH1 V CRWH1 R	CR 27324 CR 27334
	3.751 3.751 3.751	0.438 0.438 0.438	CRW1 R CRWA1 R CRWH1 V	CR 27361 CR 27362 CR 27365
	3.751 3.751 3.751 3.765	0.438 0.438 0.438 0.438	CRWH1 R CRWHA1 R CRWA1 P CRWH1 R	CR 27368 CR 27370 CR 27377 CR 27426
	3.876 3.876 3.876 3.876	0.433 0.438 0.438 0.438	CRWHA1 P CRWA1 R CRWH1 R CRWHA1 R	CR 27452 CR 27467 CR 27470 CR 27471
	3.936 3.937	0.438 0.438	CRWH1 R CRWA1 P	CR 27525 CR 27526
	4.003 4.003 4.003	0.375 0.438 0.438	CRWA1 V CRWH1 R CRWHA1 P	CR 27539 CR 27541 CR 27565 ¹⁾
	4.249 4.249	0.438 0.438	CRWH1 R CRWHA1 P	CR 27600 CR 27601
	4.331 4.500	0.500 0.469	CRWHA1 R CRWH1 R	CR 27625 CR 28848

¹⁾ Without SKF Bore Tite Coating

Radial shaft seals – CRW1, CRWA1, CRWH1 and CRWA1 – inch dimensions
 d_1 2.813 – 3.125 in.

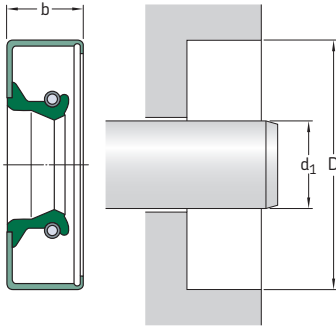

Please see pages 74 to 76 for housing bore requirements.

Dimensions	Bore	Nominal seal width	Design and lip material	Designation
Shaft		b		
d_1	D			
in.			–	–
2.813	3.751 3.876	0.438 0.438	CRWH1 R CRWH1 R	CR 28035 CR 28116
	4.003 4.249 4.249 4.250	0.438 0.313 0.438 0.438	CRWH1 R CRW1 R CRWH1 R CRWH1 P	CR 28175 CR 28270 CR 28275 CR 28276
2.844	3.939 3.939	0.500 0.550	CRWA1 R CRWA1 R	CR 28425 CR 28426
	4.003 4.003	0.438 0.500	CRWH1 R CRWH1 V	CR 28464 CR 28474
2.875	3.623 3.623	0.438 0.438	CRWH1 R CRWA1 R	CR 28654 CR 28655
	3.751 3.751 3.751	0.375 0.375 0.438	CRWA1 R CRWA1 V CRWH1 R	CR 28669 CR 28670 CR 28686
	3.751 3.751 3.751 3.751	0.438 0.438 0.438 0.438	CRWA1 R CRWH1 P CRWH1 V CRWA1 V	CR 28687 CR 28697 CR 28698 CR 28699
	3.876 3.876 3.876	0.438 0.438 0.438	CRWH1 R CRWA1 R CRWA1 V	CR 28745 CR 28746 CR 28748
	4.003 4.003 4.003 4.003	0.375 0.375 0.438 0.438	CRWA1 R CRWA1 V CRWH1 R CRWA1 R	CR 28778 CR 28779 CR 28760 CR 28761
	4.125 4.331	0.375 0.438	CRWH1 R CRWA1 P	CR 28817 CR 28841

Dimensions Shaft	Bore	Nominal seal width b	Design and lip material	Designation	
d ₁	D				
in.			–	–	
2.938	3.623	0.375	CRW1 R	CR 29218	
	3.751	0.375	CRW1 R	CR 29223	
	3.751	0.375	CRWA1 R	CR 29224	
	3.751	0.375	CRWA1 V	CR 29226	
	3.876	0.375	CRWHA1 R	CR 29263 ¹⁾	
	3.876	0.375	CRWHA1 V	CR 29262	
	3.937	0.438	CRWA1 P	CR 29273	
	4.003	0.438	CRWH1 R	CR 29316	
	4.003	0.438	CRWHA1 R	CR 29317 ¹⁾	
	4.003	0.438	CRWA1 P	CR 29322	
	4.004	0.433	CRWHA1 V	CR 29383	
	4.125	0.375	CRWH1 R	CR 29184	
	4.125	0.375	CRWHA1 R	CR 29385	
	4.501	0.438	CRWH1 R	CR 29465	
	3.000	3.500	0.375	CRW1 V	CR 29841
		3.751	0.375	CRW1 R	CR 29865 ¹⁾
		3.751	0.375	CRWA1 R	CR 29866
		3.751	0.375	CRWA1 P	CR 29867
		3.751	0.375	CRW1 V	CR 29868
		3.751	0.375	CRWA1 V	CR 29870
3.751		0.438	CRWH1 R	CR 29871	
3.751		0.438	CRWHA1 R	CR 29872	
3.876		0.313	CRW1 V	CR 29877	
3.876		0.438	CRWH1 R	CR 29887	
3.876		0.469	CRWH1 V	CR 29891	
4.003		0.375	CRW1 R	CR 29906	
4.003		0.375	CRWA1 R	CR 29907	
4.003		0.375	CRWA1 V	CR 29912	
4.003		0.375	CRWH1 P	CR 29950	
4.003		0.438	CRWHA1 P	CR 29925 ¹⁾	
4.003		0.438	CRWH1 R	CR 29951 ¹⁾	
4.003		0.438	CRWHA1 R	CR 29952	
4.003		0.438	CRWH1 V	CR 29958	
4.125		0.438	CRWH1 R	CR 30000	
4.125	0.438	CRWH1 V	CR 30003		
4.249	0.438	CRWH1 R	CR 30033 ¹⁾		
4.249	0.438	CRWHA1 P	CR 30055		
4.331	0.438	CRWH1 R	CR 30060		
4.376	0.438	CRWH1 R	CR 30070		
4.500	0.438	CRWH1 R	CR 30087		
4.500	0.438	CRWHA1 R	CR 30095		
4.501	0.438	CRWH1 V	CR 30098		
4.999	0.438	CRWH1 R	CR 30125		
3.125	3.811	0.355	CRW1 V	CR 31132	
	3.811	0.355	CRW1 R	CR 31135	
	4.003	0.375	CRWA1 R	CR 31139	
	4.003	0.375	CRWHA1 V	CR 31152	
	4.003	0.438	CRWH1 R	CR 31147	
	4.003	0.438	CRWHA1 R	CR 31148	

¹⁾ Without SKF Bore Tite Coating

Radial shaft seals – CRW1, CRWA1, CRWH1 and CRWA1 – inch dimensions
 d_1 3.125 – 3.500 in.

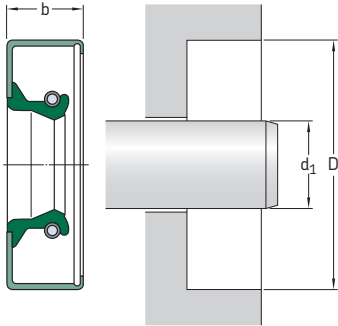

Please see **pages 74 to 76** for housing bore requirements.

Dimensions Shaft	Bore	Nominal seal width b	Design and lip material	Designation
d_1	D			
in.			–	–
3.125	4.125	0.375	CRW1 R	CR 31177
cont.	4.125	0.375	CRWA1 V	CR 31179
	4.125	0.438	CRWA1 P	CR 31173
	4.125	0.438	CRWA1 S	CR 31185
	4.125	0.438	CRWH1 R	CR 31189¹⁾
	4.249	0.438	CRWH1 R	CR 31227
	4.249	0.438	CRWA1 R	CR 31228
	4.249	0.438	CRWA1 V	CR 31237
	4.376	0.438	CRWH1 R	CR 31250
	4.376	0.438	CRWA1 P	CR 31261
	4.501	0.438	CRWH1 R	CR 31269
	4.626	0.438	CRWH1 R	CR 31299
	4.751	0.438	CRWH1 R	CR 31316
	4.999	0.438	CRWH1 R	CR 31333
	5.251	0.438	CRWH1 R	CR 31353
3.150	3.946	0.394	CRW1 V	CR 31511
3.188	4.249	0.438	CRWH1 R	CR 31758
	4.376	0.438	CRWH1 R	CR 31825
	4.501	0.438	CRWH1 R	CR 31855
	4.626	0.438	CRWH1 R	CR 31870
	4.999	0.438	CRWH1 R	CR 31955
3.250	3.876	0.375	CRW1 P	CR 32330
	4.003	0.375	CRW1 R	CR 32344
	4.003	0.375	CRWA1 P	CR 32347
	4.249	0.375	CRWA1 V	CR 32392
	4.249	0.375	CRW1 R	CR 32393
	4.249	0.375	CRWA1 R	CR 32395
	4.249	0.438	CRWH1 P	CR 32380¹⁾
	4.249	0.438	CRWA1 P	CR 32385
	4.249	0.438	CRWH1 R	CR 32396
	4.249	0.438	CRWA1 R	CR 32397
	4.249	0.438	CRWH1 V	CR 32403

¹⁾ Without SKF Bore Tite Coating

Dimensions Shaft	Bore	Nominal seal width b	Design and lip material	Designation
d ₁	D			
in.			–	–
3.250	4.376	0.438	CRWH1 R	CR 32424
cont.	4.500	0.438	CRWA1 P	CR 32448
	4.501	0.375	CRW1 R	CR 32477
	4.501	0.438	CRWH1 R	CR 32501
	4.501	0.438	CRWHA1 R	CR 32502
	4.626	0.433	CRWHA1 R	CR 32514¹⁾
	4.626	0.438	CRWH1 R	CR 32540
	4.718	0.438	CRWH1 R	CR 32555
	4.751	0.438	CRWH1 R	CR 32560
	4.999	0.438	CRWH1 R	CR 32582
	4.999	0.438	CRWHA1 R	CR 32583
3.313	4.125	0.438	CRWH1 R	CR 33033
	4.249	0.438	CRWH1 R	CR 33073
	4.500	0.438	CRWH1 R	CR 33136
	4.999	0.438	CRWH1 R	CR 33306
3.375	4.125	0.375	CRW1 R	CR 33645
	4.125	0.375	CRWA1 V	CR 34647
	4.249	0.438	CRWHA1 R	CR 33665
	4.280	0.406	CRWA1 S	CR 33654
	4.376	0.375	CRWA1 V	CR 33699
	4.376	0.375	CRW1 R	CR 33700
	4.376	0.375	CRWA1 R	CR 33701
	4.376	0.438	CRWH1 R	CR 33711
	4.376	0.438	CRWHA1 R	CR 33712
	4.501	0.438	CRWA1 V	CR 33733
	4.501	0.438	CRWH1 R	CR 33735
	4.626	0.438	CRWH1 R	CR 33772
	4.626	0.438	CRWHA1 R	CR 33773
	4.626	0.438	CRWHA1 V	CR 33775
	4.686	0.438	CRWH1 R	CR 33807¹⁾
	4.999	0.438	CRWH1 R	CR 33837¹⁾
	5.251	0.438	CRWHA1 R	CR 33866
3.438	4.249	0.375	CRW1 R	CR 34256
	4.501	0.375	CRWA1 R	CR 34279
	4.501	0.438	CRWH1 R	CR 34282
	4.501	0.438	CRWHA1 R	CR 34283
	4.626	0.438	CRWH1 R	CR 34336
	4.626	0.438	CRWHA1 R	CR 34338
	4.751	0.438	CRWA1 R	CR 34379
	4.756	0.438	CRWH1 R	CR 34383
	4.876	0.438	CRWH1 R	CR 34398
	4.999	0.438	CRWH1 R	CR 34407
	4.999	0.438	CRWHA1 R	CR 34408
3.500	4.249	0.438	CRWHA1 V	CR 34857
	4.376	0.375	CRW1 R	CR 34860
	4.376	0.375	CRWA1 R	CR 34861
	4.376	0.375	CRWA1 V	CR 34866
	4.376	0.433	CRWHA1 V	CR 34869
	4.376	0.438	CRWH1 R	CR 34867
	4.376	0.438	CRWHA1 R	CR 34868

¹⁾ Without SKF Bore Tite Coating

Radial shaft seals – CRW1, CRWA1, CRWH1 and CRWA1 – inch dimensions
 d_1 3.500 – 3.875 in.

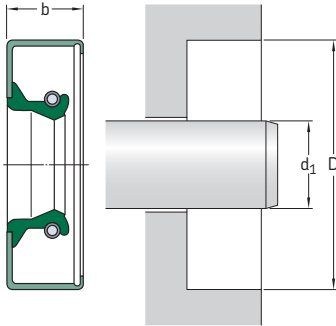

Please see **pages 74 to 76** for housing bore requirements.

Dimensions Shaft	Bore	Nominal seal width b	Design and lip material	Designation
d_1	D			
in.			–	–
3.500	4.501	0.375	CRWA1 V	CR 34883
cont.	4.501	0.375	CRW1 R	CR 34886
	4.501	0.375	CRWA1 R	CR 34887
	4.501	0.438	CRWH1 R	CR 34888
	4.501	0.438	CRWA1 R	CR 34889
	4.501	0.438	CRWHA1 P	CR 34891¹⁾
	4.501	0.438	CRWH1 V	CR 34892
	4.626	0.438	CRWH1 R	CR 34985
	4.751	0.375	CRWA1 V	CR 35039
	4.751	0.375	CRWA1 P	CR 35040
	4.751	0.438	CRWH1 R	CR 35012
	4.751	0.438	CRWHA1 R	CR 35020
	4.751	0.625	CRWH1 R	CR 35029
	4.999	0.438	CRWA1 V	CR 35080
	4.999	0.438	CRWH1 R	CR 35082
	4.999	0.438	CRWHA1 P	CR 35083
	5.126	0.438	CRWH1 R	CR 35086
	5.126	0.438	CRWHA1 R	CR 35095
	5.251	0.438	CRWH1 R	CR 35096
	5.251	0.750	CRWHA11 P	CR 35098
3.563	4.501	0.438	CRWH1 R	CR 35556
	4.626	0.438	CRWH1 R	CR 35593
	4.751	0.438	CRWH1 R	CR 35649
	4.876	0.438	CRWH1 R	CR 35676
	4.999	0.438	CRWH1 R	CR 35716
3.625	4.376	0.375	CRWA1 V	CR 36153
	4.376	0.375	CRWA1 R	CR 36155
	4.376	0.375	CRWH1 R	CR 36157
	4.376	0.375	CRWH1 P	CR 36158
	4.501	0.375	CRW1 R	CR 36166

¹⁾ Without SKF Bore Tite Coating

Dimensions Shaft	Bore	Nominal seal width b	Design and lip material	Designation
d ₁	D			
in.			–	–
3.625 cont.	4.626	0.375	CRW1 R	CR 36177
	4.626	0.375	CRWA1 V	CR 36179
	4.626	0.438	CRWH1 R	CR 36185
	4.626	0.438	CRWHA1 R	CR 36186
	4.751	0.438	CRWH1 R	CR 36220
	4.751	0.500	CRWA1 S	CR 36234
	4.876	0.438	CRWH1 R	CR 36314
	4.999	0.375	CRWA1 V	CR 36359
	4.999	0.375	CRWA1 R	CR 36361
	4.999	0.438	CRWH1 R	CR 36363
	4.999	0.438	CRWHA1 R	CR 36364
	5.251	0.375	CRWA1 R	CR 36382
	5.375	0.438	CRWHA1 R	CR 36391
3.688	4.501	0.438	CRWHA1 R	CR 36740
	4.751	0.438	CRWH1 R	CR 36770
	4.999	0.438	CRWH1 R	CR 36880
	5.126	0.438	CRWA1 R	CR 36895
	5.626	0.438	CRWA1 R	CR 36910
3.750	4.501	0.375	CRW1 R	CR 37327 ¹⁾
	4.501	0.375	CRW1 V	CR 37328
	4.501	0.469	CRWHA1 P	CR 37330
	4.502	0.469	CRWHA1 V	CR 37332
	4.750	0.438	CRWHA1 P	CR 37403
	4.751	0.375	CRW1 P	CR 37387
	4.751	0.375	CRW1 R	CR 37388
	4.751	0.375	CRWA1 R	CR 37389
	4.751	0.438	CRWA1 P	CR 37390
	4.751	0.438	CRWHA1 S	CR 37395
	4.751	0.438	CRWH1 R	CR 37396
	4.751	0.438	CRWH1 V	CR 37405
	4.876	0.438	CRWH1 R	CR 37433
	4.999	0.375	CRW1 V	CR 37524
	4.999	0.375	CRW1 R	CR 37525
	4.999	0.375	CRWA1 R	CR 37526
	4.999	0.438	CRWH1 R	CR 37532
	4.999	0.438	CRWHA1 R	CR 37533
	5.251	0.438	CRWH1 R	CR 37574
	5.251	0.438	CRWH1 V	CR 37577
3.875	4.751	0.375	CRW1 R	CR 38646
	4.751	0.375	CRWA1 R	CR 38647
	4.751	0.375	CRWA1 V	CR 38649
	4.751	0.438	CRWH1 R	CR 38653
	4.876	0.438	CRWHA1 R	CR 38673
	4.876	0.500	CRWH1 R	CR 38669
	4.876	0.500	CRWHA1 V	CR 38678
	4.999	0.375	CRW1 R	CR 38691
	4.999	0.375	CRWA1 R	CR 38692
	4.999	0.375	CRWA1 V	CR 38694
	5.126	0.438	CRWHA1 V	CR 38702
	5.126	0.438	CRWH1 R	CR 38703
	5.126	0.438	CRWHA1 R	CR 38713

¹⁾ Without SKF Bore Tite Coating

Radial shaft seals – CRW1, CRWA1, CRWH1 and CRWA1 – inch dimensions
 d_1 3.875 – 4.477 in.

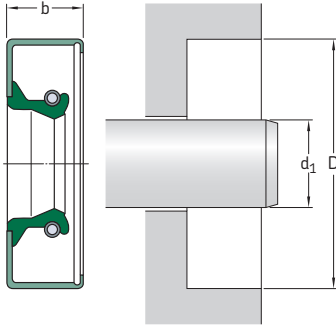

Please see pages 74 to 76 for housing bore requirements.

Dimensions Shaft	Bore	Nominal seal width b	Design and lip material	Designation
d_1	D			
in.			–	–
3.875	5.251	0.438	CRWH1 R	CR 38730
cont.	5.251	0.438	CRWA1 R	CR 38731
	5.251	0.438	CRWA1 P	CR 38739
	5.376	0.438	CRWH1 R	CR 38745
	5.626	0.433	CRWA1 R	CR 38758
	5.690	0.500	CRWH1 R	CR 38774
3.938	4.876	0.438	CRWH1 R	CR 39245
	4.999	0.438	CRWH1 R	CR 39275
	4.999	0.438	CRWH1 V	CR 39276
	4.999	0.438	CRWH1 R	CR 39277
	5.126	0.472	CRWA1 V	CR 39304
	5.251	0.438	CRWH1 R	CR 39320
	5.375	0.438	CRWH1 R	CR 39350
	5.501	0.438	CRWH1 R	CR 39423
4.000	4.876	0.438	CRW1 R	CR 39851
	4.999	0.375	CRW1 P	CR 39895
	4.999	0.375	CRWA1 V	CR 39921
	4.999	0.375	CRW1 R	CR 39922
	4.999	0.375	CRWA1 R	CR 39923
	4.999	0.438	CRWA1 P	CR 39930
	4.999	0.438	CRWH1 V	CR 39932
	4.999	0.438	CRWH1 R	CR 39933
	4.999	0.438	CRWA1 R	CR 39934
	4.999	0.438	CRWH1 S	CR 39935
	5.126	0.438	CRWH1 R	CR 39975
	5.251	0.438	CRWH1 V	CR 39996
	5.251	0.438	CRWH1 R	CR 39997
	5.251	0.438	CRWA1 R	CR 40000
	5.310	0.500	CRWA1 R	CR 40020
	5.376	0.438	CRWH1 R	CR 40036
	5.501	0.438	CRWH1 R	CR 40049

Dimensions Shaft	Bore	Nominal seal width b	Design and lip material	Designation
d ₁	D			
in.			–	–
4.000 cont.	5.626	0.375	CRWA1 R	CR 40077
	5.626	0.438	CRWH1 R	CR 40078
	5.751	0.438	CRWH1 R	CR 40108
	6.001	0.500	CRWH1 R	CR 40138
	6.250	0.500	CRWH1 R	CR 40158
4.125	4.999	0.438	CRWH1 R	CR 41125
	4.999	0.438	CRWH1 V	CR 41126 ¹⁾
	5.126	0.438	CRWH1 R	CR 41170
	5.126	0.438	CRWH1 V	CR 41171
	5.251	0.438	CRWH1 R	CR 41185
	5.251	0.438	CRWH1 V	CR 41186
	5.501	0.438	CRWH1 R	CR 41265
	5.501	0.438	CRWH1 V	CR 41266
	5.751	0.438	CRWH1 R	CR 41287
	6.001	0.438	CRWH1 R	CR 41305
	6.001	0.438	CRWH1 V	CR 41307
4.250	5.251	0.375	CRWA1 R	CR 42419
	5.251	0.375	CRW1 S	CR 42422
	5.251	0.438	CRWH1 R	CR 42426
	5.251	0.438	CRWHA1 R	CR 42427
	5.251	0.438	CRWH1 V	CR 42433
	5.373	0.438	CRWA1 V	CR 42474
	5.376	0.438	CRWH1 R	CR 42475
	5.501	0.438	CRWH1 R	CR 42528
	5.626	0.438	CRWA1 R	CR 42557
	5.751	0.438	CRWH1 R	CR 42573
	5.876	0.500	CRWH1 V	CR 42592
	6.001	0.500	CRWH1 R	CR 42616
	6.126	0.500	CRWH1 R	CR 42635
	6.250	0.500	CRWH1 R	CR 42644
	5.501	0.433	CRWHA1 P	CR 43072
4.313	5.501	0.438	CRWHA1 R	CR 43073
	5.626	0.472	CRWHA1 V	CR 43345
4.331	5.626	0.472	CRWHA1 V	CR 43345
4.375	5.376	0.438	CRWH1 R	CR 43650
	5.501	0.438	CRWH1 R	CR 43691
	5.751	0.438	CRWH1 R	CR 43751
	6.001	0.500	CRWH1 R	CR 43771
	6.063	0.500	CRWH1 R	CR 541974 ¹⁾
	6.250	0.500	CRWH1 R	CR 43820
4.438	5.501	0.500	CRWH1 R	CR 44275
	5.501	0.500	CRWH1 V	CR 44276
	5.751	0.500	CRWH1 R	CR 44295
	6.001	0.500	CRWH1 R	CR 44320
	6.250	0.500	CRWH1 R	CR 44350
4.477	6.250	0.500	CRWH1 R	CR 44630

¹⁾ Without SKF Bore Tite Coating

Radial shaft seals – CRW1, CRWA1, CRWH1 and CRWA1 – inch dimensions

d_1 4.500 – 5.125 in.

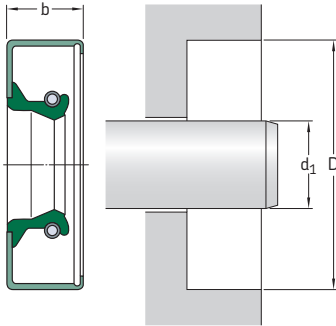

Please see pages 74 to 76 for housing bore requirements.

Dimensions Shaft	Bore	Nominal seal width	Design and lip material	Designation
d_1	D	b		
in.			–	–
4.500	5.251	0.438	CRWH1 R	CR 44913
	5.251	0.438	CRWA1 V	CR 44917
	5.376	0.438	CRWH1 R	CR 44920
	5.376	0.438	CRWA1 V	CR 44926
	5.501	0.375	CRW1 R	CR 44959
	5.501	0.375	CRWA1 R	CR 44960
	5.501	0.435	CRWH1 V	CR 44980
	5.501	0.438	CRWH1 R	CR 44967
	5.501	0.438	CRWA1 R	CR 44968
	5.501	0.438	CRWH1 V	CR 44973
	5.626	0.438	CRWH1 R	CR 45032
	5.626	0.438	CRWA1 V	CR 45033
	5.751	0.375	CRWA1 V	CR 45064
	5.751	0.438	CRWH1 R	CR 45069
	5.751	0.438	CRWA1 R	CR 45070
	6.001	0.500	CRWH1 R	CR 45110
	6.001	0.500	CRWA1 R	CR 45111
	6.001	0.500	CRWA1 V	CR 45112
	6.126	0.563	CRWH1 R	CR 45140
	6.250	0.500	CRWH1 R	CR 45150
4.625	5.626	0.500	CRWH1 R	CR 46144
	5.626	0.500	CRWH1 V	CR 46155
	5.751	0.500	CRWH1 R	CR 46200
	5.751	0.500	CRWH1 S	CR 46208
	6.001	0.500	CRWH1 R	CR 46285
	6.250	0.500	CRWH1 R	CR 46324
4.688	5.751	0.512	CRWH1 S	CR 46790
	5.751	0.512	CRWH1 R	CR 46800
	6.250	0.500	CRWH1 R	CR 46950

Dimensions Shaft d ₁	Bore D	Nominal seal width b	Design and lip material	Designation
in.			–	–
4.750	5.749	0.438	CRW1 P	CR 47375
	5.751	0.500	CRW1 V	CR 47379
	5.751	0.500	CRWA1 V	CR 47382
	5.751	0.500	CRW1 R	CR 47383
	5.751	0.500	CRWH1 R	CR 47394
	5.751	0.500	CRWA1 R	CR 47395
	5.875	0.500	CRWH1 R	CR 47441
	6.001	0.500	CRWH1 R	CR 47474
	6.001	0.500	CRWA1 R	CR 47475
	6.001	0.500	CRW1 V	CR 47481
	6.250	0.500	CRWH1 R	CR 47583
	6.250	0.500	CRWA1 V	CR 47586
4.813	5.751	0.563	CRWH1 P	CR 48060
	5.751	0.563	CRWH1 V	CR 48062
	5.751	0.563	CRWH1 S	CR 48065
4.875	6.001	0.500	CRWH1 V	CR 48692
	6.001	0.500	CRWH1 R	CR 48693
	6.126	0.500	CRWH1 R	CR 48726
	6.250	0.500	CRWA1 R	CR 48768
	6.250	0.500	CRWH1 R	CR 48769
	6.250	0.500	CRWH1 V	CR 48772
4.921	6.375	0.500	CRWA1 V	CR 49274
4.938	6.001	0.500	CRWH1 R	CR 49251
	6.250	0.500	CRWH1 R	CR 49301
5.000	6.001	0.500	CRWA1 V	CR 49927
	6.001	0.500	CRWH1 R	CR 49928
	6.001	0.500	CRWA1 R	CR 49929
	6.126	0.500	CRW1 V	CR 49960
	6.250	0.500	CRWH1 R	CR 49966
	6.250	0.500	CRW1 R	CR 49984
	6.250	0.500	CRWA1 R	CR 49985
	6.250	0.500	CRWH1 P	CR 49990 ¹⁾
	6.250	0.500	CRWH1 V	CR 49991
	6.250	0.500	CRWA1 R	CR 49998
	6.375	0.500	CRWH1 R	CR 50130
	6.375	0.500	CRWA1 R	CR 50138
6.500	6.500	0.500	CRWH1 R	CR 50148
	6.500	0.500	CRWH1 V	CR 50151
6.750	6.750	0.500	CRWH1 R	CR 50168
	6.750	0.500	CRWA1 R	CR 50172
5.063	6.126	0.500	CRWH1 R	CR 50618
	6.375	0.500	CRWH1 R	CR 50650
5.125	6.126	0.500	CRWA1 R	CR 51240
	6.126	0.500	CRW1 V	CR 51243
	6.126	0.500	CRW1 R	CR 51247
	6.250	0.500	CRWA1 R	CR 51252
	6.250	0.500	CRWA1 V	CR 51253
	6.375	0.500	CRWH1 R	CR 51248 ¹⁾
6.375	0.500	CRWH1 V	CR 51255	

¹⁾ Without SKF Bore Tite Coating

Radial shaft seals – CRW1, CRWA1, CRWH1 and CRWA1 – inch dimensions
 d_1 5.188 – 7.000 in.

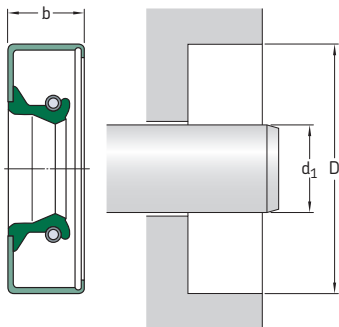

Please see **pages 74 to 76** for housing bore requirements.

Dimensions Shaft	Bore	Nominal seal width b	Design and lip material	Designation
d_1	D	b		
in.			–	–
5.188	6.501	0.625	CRWH1 V	CR 51852
5.250	6.001	0.375	CRW1 R	CR 52440
	6.001	0.500	CRWH1 V	CR 52443
	6.250	0.500	CRWH1 R	CR 52445
	6.250	0.500	CRWH1 V	CR 52447
	6.500	0.500	CRWH1 R	CR 52488
	6.500	0.500	CRWH1 V	CR 52489
	6.750	0.500	CRWH1 R	CR 52648
	6.750	0.500	CRWH1 V	CR 52649
5.375	6.625	0.500	CRWH1 R	CR 53701
	6.625	0.500	CRWH1 V	CR 53702
	6.750	0.500	CRWH1 V	CR 53771
	6.750	0.500	CRWH1 R	CR 53775
5.500	6.250	0.500	CRWA1 R	CR 54925
	6.500	0.500	CRWH1 R	CR 54931
	6.500	0.500	CRWH1 V	CR 54934
	6.500	0.500	CRWH1 P	CR 54936
	6.750	0.500	CRW1 R	CR 54959
	6.750	0.500	CRWA1 R	CR 54960
	6.750	0.500	CRWA1 R	CR 54971
	6.750	0.500	CRWA1 R	CR 54972
	6.750	0.500	CRWH1 V	CR 54974
5.512	6.693	0.472	CRWH1 V	CR 546747¹⁾
5.625	6.625	0.500	CRWH1 R	CR 56101
	6.625	0.500	CRWH1 V	CR 56102
	6.875	0.500	CRWH1 R	CR 56136
	6.875	0.500	CRWH1 V	CR 56137

¹⁾ Without SKF Bore Tite Coating

Dimensions Shaft d ₁	Bore D	Nominal seal width b	Design and lip material	Designation
in.			–	–
5.625 cont.	7.125 7.125	0.500 0.500	CRWHA1 R CRWHA1 V	CR 56160 CR 56161
5.750	6.625 6.625	0.500 0.500	CRWH1 R CRW1 V	CR 57505 CR 57506
	6.750 6.750 6.751	0.500 0.500 0.500	CRWH1 R CRWH1 V CRWHA1 R	CR 57510 CR 57522 CR 57509¹⁾
	7.000 7.000 7.000	0.500 0.500 0.500	CRWH1 R CRWH1 V CRWHA1 R	CR 57521 CR 57523 CR 57531
5.875	7.125 7.125 7.125	0.500 0.500 0.500	CRWH1 R CRWH1 V CRWHA1 R	CR 58716 CR 58717 CR 58741
	7.500	0.500	CRWH1 R	CR 58760
6.000	6.750 6.750	0.500 0.500	CRWA1 V CRW1 V	CR 59999 CR 60000
	7.500 7.500 7.500	0.500 0.500 0.500	CRWA1 R CRWHA1 V CRWHA1 R	CR 60016 CR 60026 CR 60028
6.125	7.125 7.625 7.625	0.625 0.625 0.625	CRWH1 R CRWH1 R CRWH1 P	CR 61210¹⁾ CR 61255¹⁾ CR 61256¹⁾
6.250	7.252 7.500 7.500	0.500 0.500 0.500	CRWH1 R CRWH1 R CRWH1 V	CR 62482¹⁾ CR 62495¹⁾ CR 62497
	7.750 7.875	0.500 0.625	CRWH1 R CRWH1 R	CR 62535 CR 62572
6.375	7.375	0.625	CRWH1 R	CR 63700
	7.875 7.875	0.563 0.625	CRWHA1 R CRWH1 R	CR 63734 CR 63733¹⁾
6.500	7.500 7.500 7.500	0.500 0.500 0.500	CRWA1 R CRWH1 R CRWH1 V	CR 64993 CR 64994¹⁾ CR 64998
	8.000 8.000	0.500 0.500	CRW1 R CRWHA1 R	CR 65021 CR 65037¹⁾
6.625	8.125	0.500	CRWH1 R	CR 66241¹⁾
6.750	8.000 8.250	0.500 0.500	CRWH1 R CRWH1 R	CR 67515 CR 67533¹⁾
6.875	8.375	0.500	CRWH1 R	CR 68745¹⁾
7.000	8.000 8.250	0.630 0.625	CRWH1 R CRWH1 R	CR 70016 CR 70028¹⁾
	8.500 8.500 8.500 8.500	0.500 0.625 0.625 0.625	CRWA1 R CRWH1 R CRWHA1 R CRWHA1 V	CR 70080 CR 70052 CR 70053 CR 70054

¹⁾ Without SKF Bore Tite Coating

Radial shaft seals – CRW1, CRWA1, CRWH1 and CRWA1 – inch dimensions
 d_1 7.125 – 12.250 in.

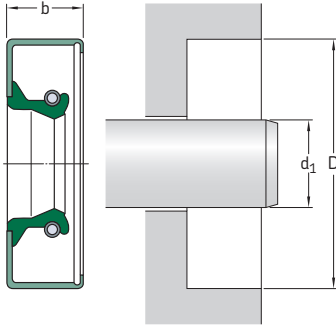

Please see **pages 74 to 76** for housing bore requirements.

Dimensions Shaft	Bore D	Nominal seal width b	Design and lip material	Designation
d_1	D	b		
in.			–	–
7.125	8.625	0.625	CRWH1 R	CR 71245¹⁾
7.250	8.250	0.625	CRW1 R	CR 72515¹⁾
	8.750	0.625	CRWA1 R	CR 72539
	8.750	0.750	CRWH1 P	CR 72542¹⁾
	9.055	0.625	CRWA1 R	CR 72570
7.375	8.875	0.625	CRWH1 R	CR 73745¹⁾
7.500	8.500	0.625	CRWH1 R	CR 75030¹⁾
	9.000	0.625	CRWH1 R	CR 75050
	9.000	0.625	CRWA1 P	CR 75052
7.625	8.625	0.563	CRWH1 R	CR 76215¹⁾
	9.125	0.625	CRWH1 R	CR 76255¹⁾
7.750	9.250	0.625	CRWH1 R	CR 77540¹⁾
7.875	9.250	1.000	CRWA1 R	CR 78725¹⁾
	9.375	0.625	CRWH1 R	CR 78738¹⁾
8.000	9.000	0.625	CRWH1 R	CR 79960¹⁾
	9.000	0.625	CRWA1 R	CR 79961¹⁾
	9.250	0.625	CRWH1 R	CR 79997¹⁾
	9.250	0.625	CRWA1 R	CR 79998
	9.500	0.625	CRWH1 R	CR 80010
8.125	10.000	0.625	CRWA1 R	CR 80038¹⁾
	10.125	0.625	CRWH1 R	CR 81245¹⁾
	10.125	0.625	CRWA1 R	CR 81246¹⁾
	10.125	0.625	CRWH1 R	CR 81246¹⁾
8.250	9.250	0.625	CRWH1 R	CR 82510¹⁾
	9.252	0.500	CRWH1 R	CR 82512
	9.500	0.578	CRW1 R	CR 82521¹⁾
	10.250	0.625	CRWH1 R	CR 82560¹⁾
	10.250	0.625	CRWH1 R	CR 82560¹⁾

¹⁾ Without SKF Bore Tite Coating

Dimensions Shaft	Bore	Nominal seal width b	Design and lip material	Designation
d ₁	D			
in.			–	–
8.500	9.750	0.625	CRWH1 R	CR 85002
	10.000	0.625	CRWH1 R	CR 85009¹⁾
	10.500	0.625	CRWH1 R	CR 85015¹⁾
	10.625	0.625	CRWHA1 R	CR 85085¹⁾
8.625	10.625	0.625	CRWH1 R	CR 86260¹⁾
8.750	10.750	0.625	CRWH1 R	CR 87541¹⁾
8.875	10.125	0.625	CRWH1 R	CR 88710¹⁾
	10.875	0.625	CRWH1 R	CR 88760¹⁾
9.000	10.000	0.625	CRWH1 R	CR 90006¹⁾
	11.000	0.625	CRWH1 R	CR 90036¹⁾
9.250	11.250	0.625	CRWHA1 R	CR 92536
	12.750	0.625	CRWHA1 R	CR 92570¹⁾
	12.750	1.250	CRWHA1 R	CR 92574¹⁾
9.500	10.500	0.438	CRW1 R	CR 95048
	11.500	0.625	CRW1 R	CR 95062
9.625	11.625	0.625	CRWH1 R	CR 96245¹⁾
	11.125	0.625	CRWH1 R	CR 97542¹⁾
	11.250	0.625	CRWH1 R	CR 97545¹⁾
	11.750	0.625	CRWH1 R	CR 97550¹⁾
10.000	11.252	0.625	CRWHA1 R	CR 100044¹⁾
	12.000	0.625	CRWH1 R	CR 100051¹⁾
	12.000	0.625	CRWA1 R	CR 100075
10.250	11.250	0.563	CRWH1 R	CR 102520¹⁾
	12.250	0.625	CRWH1 R	CR 102540¹⁾
10.500	11.750	0.625	CRWH1 R	CR 105010¹⁾
	12.500	0.625	CRWH1 R	CR 105051¹⁾
10.750	12.750	0.625	CRWH1 R	CR 107551¹⁾
11.000	12.250	0.625	CRWHA1 R	CR 110030¹⁾
	13.000	0.625	CRWH1 R	CR 110051¹⁾
11.375	13.000	0.625	CRW1 R	CR 113740¹⁾
11.500	13.000	0.625	CRWH1 R	CR 115021¹⁾
	13.500	0.625	CRWH1 R	CR 115041¹⁾
12.000	14.000	0.625	CRW1 R	CR 120060¹⁾
12.250	13.375	0.625	CRWH1 R	CR 122555¹⁾
	13.813	0.625	CRW1 R	CR 122580¹⁾
	14.250	1.000	CRWHA1 R	CR 122590¹⁾

¹⁾ Without SKF Bore Tite Coating

Radial shaft seals

CRW5 and CRWA5 seals

CRW5 and CRWA5 seals are designed to withstand moderate pressure differentials. They have an SKF WAVE lip to reduce heat generation and a metal outside diameter for easy installation and a firm and accurate fit in the housing bore. See **pages 57** and **58** for more information on SKF WAVE lip design. Most of them have SKF Bore Tite Coating on the outside diameter. The CRWA5 seals have an auxiliary lip, providing additional contaminant exclusion ability. A shoulder or retaining ring should be used at the low-pressure side of the seal to prevent it from being pressed out of the housing bore.

CRW5: Seal with one steel case, SKF WAVE lip and a carbon steel garter spring.

CRWA5: Seal with one steel case, SKF WAVE lip, a carbon steel garter spring and an auxiliary, contacting lip.

The CRW5 and CRWA5 seals are available in inch sizes with sealing lips made of either nitrile rubber or the SKF fluoro rubber compound SKF Duralife. Other materials are also available on request.

See **matrix 1** on **pages 90** and **91** for permissible operating conditions.



Radial shaft seals – CRW5 and CRWA5 – inch dimensions

d_1 0.313 – 0.875 in.

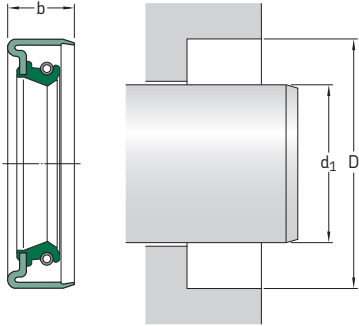

2.3

Please see pages 74 to 76 for housing bore requirements.

Dimensions Shaft	Bore	Nominal seal width b	Design and lip material	Designation
d_1	D	b		
in.			–	–
0.313	0.686	0.313	CRWA5 R	CR 3094 ¹⁾
	0.749	0.250	CRWA5 R	CR 3101 ¹⁾
	0.749	0.250	CRWA5 V	CR 3103 ¹⁾
	0.999	0.313	CRWA5 R	CR 3171 ¹⁾
0.375	0.749	0.250	CRW5 R	CR 3689 ¹⁾
	1.124	0.375	CRW5 V	CR 3807
0.500	0.875	0.313	CRWA5 R	CR 4940
	0.875	0.313	CRWA5 V	CR 4941
	0.999	0.250	CRWA5 V	CR 4991
	0.999	0.313	CRWA5 R	CR 4996
	1.124	0.250	CRWA5 R	CR 5069
	1.124	0.250	CRWA5 V	CR 5072
0.625	0.999	0.250	CRWA5 R	CR 6151
	1.124	0.250	CRW5 R	CR 6191
	1.124	0.374	CRWA5 V	CR 6231
	1.124	0.375	CRWA5 R	CR 6229
	1.126	0.250	CRW5 R	CR 6232
	1.250	0.313	CRWA5 R	CR 6280 ¹⁾
	1.250	0.313	CRWA5 V	CR 6285 ¹⁾
	1.375	0.250	CRW5 P	CR 6371
	1.375	0.375	CRWA5 R	CR 6388
	1.500	0.313	CRW5 V	CR 6393
0.750	1.250	0.250	CRWA5 R	CR 7434
	1.250	0.375	CRWA5 R	CR 7449
	1.375	0.250	CRWA5 V	CR 7509
0.875	1.250	0.250	CRWA5 V	CR 8634
	1.375	0.250	CRWA5 R	CR 8660
	1.375	0.250	CRWA5 V	CR 8665
	1.497	0.313	CRWA5 V	CR 8694

¹⁾ Without SKF Bore Tite Coating

Radial shaft seals – CRW5 and CRWA5 – inch dimensions

d_1 0.984 – 2.500 in.

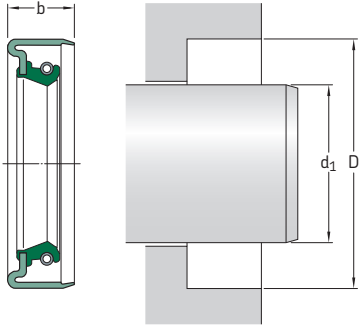

Please see pages 74 to 76 for housing bore requirements.

Dimensions Shaft	Bore	Nominal seal width b	Design and lip material	Designation
d_1	D	b		
in.			–	–
0.984	1.596 1.752	0.250 0.313	CRWA5 R CRWA5 V	CR 9700 CR 9805
1.000	1.375 1.499 1.499 1.499	0.250 0.250 0.250 0.250	CRWA5 R CRWA5 R CRW5 R CRWA5 V	CR 9814 CR 9843 CR 9855¹⁾ CR 9858
	1.500 1.752 2.000	0.250 0.313 0.313	CRWA5 R CRWA5 R CRWA5 R	CR 9863 CR 9967 CR 10131
1.125	1.626	0.250	CRWA5 V	CR 11139
1.250	1.687 1.750 1.750	0.313 0.250 0.250	CRWA5 R CRWA5 V CRWA5 R	CR 12333 CR 12339 CR 12360
	1.997 2.328 2.502	0.438 0.500 0.500	CRWA5 V CRWA5 R CRWA5 R	CR 12438 CR 12609 CR 12640
1.500	1.997 2.064 2.311 2.328	0.250 0.375 0.500 0.500	CRWA5 V CRWA5 V CRWA5 V CRWA5 R	CR 14844 CR 14868 CR 14979 CR 14977
1.750	2.502	0.500	CRWA5 R	CR 17374
1.938	2.675 2.835	0.250 0.250	CRWA5 R CRWA5 R	CR 19213 CR 19278
2.500	3.251	0.350	CRWA5 R	CR 24892

¹⁾ Without SKF Bore Tite Coating

Radial shaft seals

HDW1 seals

HDW1 seals are heavy-duty SKF WAVE lip seals, designed for use in grease or oil lubricated applications. The seals are produced standard with a heavy-duty seal body, SKF Bore Tite Coating on the metal outside diameter, SKF WAVE lip in nitrile rubber, and a carbon steel garter spring.

The rigid seal body can withstand operating pressures up to 0,24 MPa (35 *psi*), dynamic, and 0,34 MPa (50 *psi*), static, while withstanding shaft speeds up to 25 m/s (4 900 *ft/min*) at shaft diameters < 203 mm (8 *in.*).

The HDW1 seals are available in inch sizes.



Radial shaft seals – HDW1 – inch dimensions

d_1 5.000 – 7.938 in.

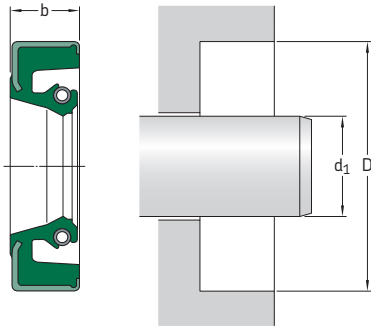

Please see pages 74 to 76 for housing bore requirements.

Dimensions			Design and lip material	Designation
Shaft	Bore	Nominal seal width		
d_1	D	b		
in.			–	–
5.000	6.125 7.125	0.500 0.500	HDW1 R HDW1 R	CR 49951 CR 50186
5.063	6.125	0.500	HDW1 R	CR 50620
5.125	6.625 7.000	0.500 0.500	HDW1 R HDW1 R	CR 51277 CR 51330
5.188	6.250	0.500	HDW1 R	CR 51800
5.250	6.750 7.125	0.500 0.500	HDW1 R HDW1 R	CR 52651 CR 52655
5.313	6.375	0.500	HDW1 R	CR 53100
5.438	6.625	0.500	HDW1 R	CR 54300
5.875	6.875 7.000	0.500 0.500	HDW1 R HDW1 R	CR 58709¹⁾ CR 58710
5.938	7.000	0.500	HDW1 R	CR 59300
6,000	7.250	0.500	HDW1 R	CR 60009
6.063	7.500	0.500	HDW1 R	CR 60650
6.125	7.125 7.250 7.375	0.500 0.500 0.500	HDW1 R HDW1 R HDW1 R	CR 61215 CR 61230 CR 61235
6.250	7.250	0.500	HDW1 R	CR 62480
6.375	7.500	0.500	HDW1 R	CR 63717
6.438	7.500	0.500	HDW1 R	CR 64330

Dimensions			Design and lip material	Designation
Shaft	Bore	Nominal seal width		
d_1	D	b		
in.			–	–
6.625	7.625 7.750 7.875 8.000	0.500 0.500 0.500 0.500	HDW1 R HDW1 R HDW1 R HDW1 R	CR 66217 CR 66219 CR 66222 CR 66230
6.750	7.750 8.750	0.500 0.500	HDW1 R HDW1 R	CR 67510 CR 67600
6.875	8.250 8.500	0.500 0.500	HDW1 R HDW1 R	CR 68730 CR 68760
7.125	8.250	0.500	HDW1 R	CR 71220
7.375	8.375 8.500	0.500 0.500	HDW1 R HDW1 R	CR 73720 CR 73730
7.500	8.750 9.250	0.500 0.500	HDW1 R HDW1 R	CR 75046 CR 75069
7.625	8.875	0.500	HDW1 R	CR 76225
7.750	8.750	0.500	HDW1 R	CR 77506
7.875	8.875	0.500	HDW1 R	CR 78710
7.938	9.125	0.500	HDW1 R	CR 79620

¹⁾ Stainless steel garter spring

Radial shaft seals

HMS4 and HMSA7 seals

HMS4 and HMSA7 seals are primarily available in inch sizes but are also available in a very limited number of metric sizes that are in the process of being replaced by the HMS5 and HMSA10 seals. Contact your SKF representative for updated information on availability of metric sizes.

HMS4: Seal with rubber outside diameter, a carbon steel reinforcement ring and either a carbon or stainless steel garter spring.

HMSA7: Seal with rubber outside diameter, a carbon steel reinforcement ring, an auxiliary, contacting lip and either a carbon or stainless steel garter spring.

HMS4 and HMSA7 seals are available in nitrile rubber for general-purpose applications and in fluoro rubber, providing improved high-temperature and chemical resistance.

See **matrix 1** on **pages 90** and **91** for permissible operating conditions.



Radial shaft seals – HMS4 and HMSA7 seals – metric dimensions

d_1 10 – 230 mm

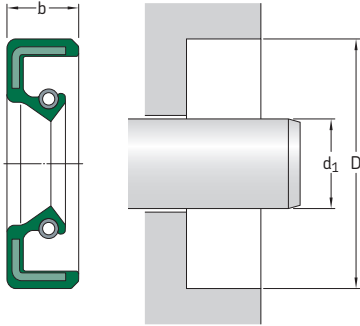

Please see **pages 74 to 76** for housing bore requirements.

Dimensions		Nominal seal width b	Design and lip material	Designation
Shaft	Bore			
d_1	D			
mm			–	–
10	24 26	7	HMS4 R HMS4 R	CR 10x24x7 HMS4 R CR 10x26x7 HMS4 R
12	24	7	HMS4 R	CR 12x24x7 HMS4 R
17	28 40	7 10	HMS4 R HMS4 R	CR 17x28x7 HMS4 R CR 17x40x10 HMS4 R
19	32	7	HMS4 R	CR 19x32x7 HMS4 R
25	52 52	8 10	HMS4 R HMS4 R	CR 25x52x8 HMS4 R CR 25x52x10 HMS4 R
27	42	10	HMS4 R	CR 27x42x10 HMS4 R
28	40	7	HMS4 R	CR 28x40x7 HMS4 R
30	47 62	7 10	HMSA7 V HMS4 R	CR 30x47x7 HMSA7 V CR 30x62x10 HMS4 R
33	50	6	HMSA7 R	CR 33x50x6 HMSA7 R
42	72	8	HMS4 R	CR 42x72x8 HMS4 R
45	85	10	HMS4 R	CR 45x85x10 HMS4 R
65	95	10	HMS4 R	CR 65x95x10 HMS4 R
80	110	12	HMS4 R	CR 80x110x12 HMS4 R
85	110	12	HMS4 R	CR 85x110x12 HMS4 R
120	150	12	HMS4 V	CR 120x150x12 HMS4 V
140	160	13	HMS4 R	CR 140x160x13 HMS4 R
230	260	15	HMS4 R	CR 230x260x15 HMS4 R

The metric range of HMS4 and HMSA7 seals are in the process of being replaced by the HMS5 and HMSA10 seals. Contact your SKF representative for updated information on availability of metric sizes.

Radial shaft seals – HMS4 and HMSA7 seals – inch dimensions

d_1 0.370 – 1.594 in.

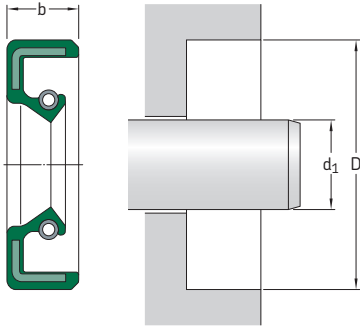

Please see pages 74 to 76 for housing bore requirements.

Dimensions Shaft	Bore	Nominal seal width	Design and lip material	Designation
d_1	D	b		
in.			–	–
0.370	0.606	0.310	HMSA76 R	CR 3626
0.500	1.010	0.204	HMSA7 V	CR 5008
0.685	1.181	0.276	HMSA7 R	CR 6757
0.736	1.378	0.276	HMSA7 R	CR 7400
0.748	1.496	0.300	HMSA7 R	CR 7251
0.813	1.250	0.375	HMS4 R	CR 8019
0.906	1.338	0.315	HMSA7 R	CR 9065
	1.339	0.256	HMS4 R	CR 9006
	1.383	0.250	HMS4 P	CR 9010
	1.575	0.276	HMSA7 P	CR 9068
0.984	1.496	0.236	HMSA7 V	CR 9701
1.000	2.441	0.375	HMSA7 R	CR 10178
1.063	1.575	0.315	HMSA7 V	CR 10584
	1.693	0.355	HMSA7 P	CR 10634
1.102	1.614	0.276	HMSA7 P	CR 10944
	1.693	0.276	HMSA7 P	CR 10494
	1.693	0.315	HMSA7 R	CR 10927
1.125	1.630	0.313	HMS4N R	CR 11143
1.142	1.693	0.315	HMSA7 P	CR 11422
	1.772	0.315	HMSA7 V	CR 11429
	2.047	0.433	HMSA7 R	CR 14116
1.181	1.693	0.315	HMSA7 V	CR 11672
	1.732	0.276	HMSA7 P	CR 11612
	1.772	0.276	HMS47 R	CR 11691
	1.772	0.276	HMSA7 P	CR 11589
	2.126	0.354	HMSA7 P	CR 11673
	2.126	0.354	HMSA7 R	CR 11674

Dimensions Shaft	Bore	Nominal seal width b	Design and lip material	Designation
d ₁	D			
in.			–	–
1.221	1.811	0.315	HMSA7 S	CR 12301
1.250	1.752 1.752 2.835	0.313 0.391 0.375	HMS4 R HMSA7 R HMSA7 R	CR 12371 CR 12355 CR 12668
1.260	1.732 1.811 2.087	0.236 0.236 0.276	HMSA7 P HMSA7SP P HMSA7 P	CR 12706 CR 12718 CR 12747
1.281	2.000	0.375	HMSA7 R	CR 12830
1.299	1.810 1.850	0.276 0.313	HMSA7 R HMSA7 P	CR 12812 CR 12886
1.301	1.969	0.469	HMSA7 R	CR 12900
1.339	1.929 2.087	0.315 0.315	HMSA7 P HMSA7 R	CR 13427 CR 13435
1.375	2.063	0.374	HMS4 R	CR 13596
1.378	1.614 1.851 1.929 1.969	0.359 0.276 0.236 0.275	HMS41 R HMSA7 R HMSA7 R HMS4 S	CR 13911 CR 555364 CR 13857 CR 13943
	2.097 2.165	0.313 0.433	HMSA7 P HMSA7 R	CR 13953 CR 550233
1.417	1.732 1.811 1.929 3.543	0.197 0.394 0.276 0.394	HMSA7 R HMSA7 P HMSA7 P HMSA7SP R	CR 14058 CR 14033 CR 14008 CR 14087
1.418	2.521	0.512	HMSA7 R	CR 550218
1.437	2.012	0.312	HMSA7SP V	CR 14215
1.457	1.987 2.000 2.205 3.071	0.276 0.276 0.354 0.472	HMSA7 P HMSA7 R HMS4 R HMS4SPL R	CR 14477 CR 14601 CR 14566 CR 14484
1.496	1.969 2.087 2.362	0.315 0.304 0.433	HMSA7 S HMSA7 V HMSA7SP S	CR 14713 CR 14759 CR 14756
1.504	1.937	0.475	HMSA76 P	CR 15270
1.515	2.087	0.315	HMSA7 P	CR 15500
1.535	1.969 2.047	0.276 0.276	HMSA7 V HMSA7 P	CR 15451 CR 15300
1.552	2.447	0.500	HMSA78 RT	CR 15440
1.575	2.047 2.126 2.165	0.276 0.394 0.236	HMSA7 V HMSA7 P HMSA7 V	CR 15800 CR 15881 CR 15818
	2.205 2.283 2.461	0.276 0.236 0.433	HMS4 R HMSA7 P HMSA7 R	CR 550259 CR 15736 CR 15558
1.594	2.067 2.283	0.236 0.315	HMSA7 P HMSA7 P	CR 15910 CR 15920

Radial shaft seals – HMS4 and HMSA7 seals – inch dimensions

d_1 1.614 – 3.465 in.

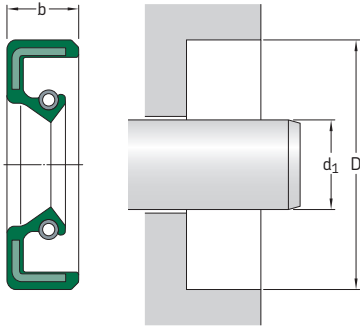

Please see **pages 74 to 76** for housing bore requirements.

Dimensions Shaft	Bore	Nominal seal width	Design and lip material	Designation
d_1	D	b		
in.			–	–
1.614	2.126 2.323	0.236 0.315	HMSA7 P HMS4 R	CR 16003 CR 16023
1.654	2.323 2.362 2.480	0.303 0.335 0.276	HMS4 R HMSA7 V HMS4 R	CR 16536 CR 16533 CR 550253
1.685	2.165	0.433	HMSA7 R	CR 16620
1.688	2.551	0.470	HMSA7 R	CR 16735
1.693	2.146 2.165	0.236 0.315	HMSA7 V HMSA7 V	CR 16889 CR 16893
1.732	2.165 2.320 2.362 3.622	0.236 0.260 0.394 0.748	HMSA7 P HMS4 R HMSA7 V HMSA7SP R	CR 17122 CR 17134 CR 17330 CR 17193
1.772	2.638 2.638 2.638 3.130	0.315 0.394 0.472 0.571	HMSA7 V HMSA7 V HMSA7S V HMSA7S V	CR 17907 CR 17921 CR 17916 CR 17683
1.811	2.283 2.480 3.543	0.276 0.300 0.630	HMSA7 R HMS4 P HMSA7SP P	CR 17897 CR 18014 CR 18000
1.875	2.716 2.830	0.394 0.391	HMSA7 P HMS4 R	CR 18623 CR 550185
1.890	2.362 2.624	0.276 0.315	HMSA7 P HMS4 S	CR 18897 CR 18895
1.929	2.441	0.441	HMSA7 P	CR 19097
2.045	2.835	0.618	HMSA7SP P	CR 20445
2.047	2.677	0.512	HMSA7SP R	CR 20428
2.063	2.661	0.188	HMS4 R	CR 20525

Dimensions Shaft d ₁	Bore D	Nominal seal width b	Design and lip material	Designation
in.			–	–
2.086	2.685	0.276	HMSA7 R	CR 20906
2.125	2.953	0.472	HMSA7 P	CR 21128
2.205	2.843 2.953	0.315 0.433	HMS4SPL P HMSA7SP R	CR 22024 CR 22031
2.244	2.638	0.236	HMSA7 R	CR 22225
2.283	2.910 2.953 3.197	0.390 0.276 0.197	HMSA7 P HMS4SPL P HMS4 S	CR 22842 CR 22840 CR 22837
2.323	3.937	0.394	HMSA7SP P	CR 23286
2.362	3.228	0.472	HMSA7 S	CR 23446
2.519	5.236	0.511	HMSA7SP R	CR 25190
2.520	3.150	0.315	HMS4 S	CR 25171
2.559	3.189 3.307	0.276 0.354	HMSA7 P HMSA7 S	CR 25518 CR 25419
2.638	3.503	0.354	HMSA7 P	CR 26387
2.677	3.307	0.335	HMSA7 S	CR 26625
2.717	3.380 3.386	0.310 0.315	HMSA7 V HMSA7 P	CR 26749 CR 26748
2.756	3.425 3.844	0.335 0.315	HMSA7 S HMSA7 R	CR 27723 CR 27764
2.832	3.622	0.374	HMSA7 V	CR 28332
2.835	3.780	0.354	HMSA7 P	CR 28308
2.913	3.858	0.472	HMSA7 P	CR 29112
2.992	3.623 3.858	0.385 0.472	HMSA7 V HMSA7 S	CR 29862 CR 29685
3.040	3.937	0.250	HMS4 R	CR 30360
3.071	6.417	0.630	HMSA7SP R	CR 30771
3.150	3.780 3.858	0.354 0.393	HMSA7 V HMSA7 V	CR 31506 CR 31507
3.228	3.791 3.920 3.937	0.315 0.500 0.354	HMSA7 P HMSA7 V HMSA7 V	CR 32283 CR 32289 CR 32715
3.307	4.094	0.433	HMSA7 R	CR 33405
3.346	4.094	0.354	HMSA7 P	CR 33454
3.375	3.948	0.375	HMSA7 P	CR 33628
3.386	4.055	0.315	HMSA7 V	CR 33861
3.425	3.937 3.937	0.295 0.315	HMSA7 V HMSA7 S	CR 34115 CR 34120
3.465	4.252 4.252	0.427 0.453	HMS4 V HMSA7 V	CR 34611 CR 34116

Radial shaft seals – HMS4 and HMSA7 seals – inch dimensions
 d_1 3.543 – 12.750 in.

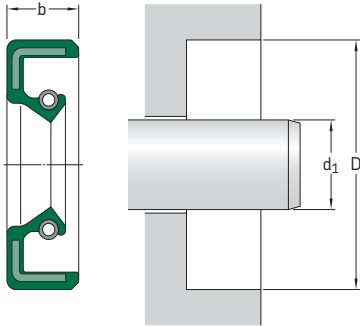

Please see **pages 74 to 76** for housing bore requirements.

Dimensions Shaft	Bore	Nominal seal width	Design and lip material	Designation
d_1	D	b		
in.			–	–
3.543	4.134 4.331 4.528	0.394 0.354 0.512	HMSA7 V HMSA7 S HMSA7 P	CR 35405 CR 35409 CR 35422
3.583	4.370	0.410	HMSA7 V	CR 35910
3.622	4.331	0.374	HMSA7 V	CR 36005
3.625	4.240	0.380	HMSA7 V	CR 36147
3.661	4.252 4.331 4.488	0.394 0.276 0.551	HMSA7 P HMSA7 V HMSA7 V	CR 36660 CR 36658 CR 36601
3.740	4.646	0.394	HMSA7 S	CR 37030
3.750	4.500 4.501 4.501 4.501	0.381 0.376 0.380 0.380	HMSA7 P HMS4 V HMS4 S HMSA7 V	CR 37338 CR 37341 CR 37340 CR 37342
3.778	4.567	0.354	HMSA7 V	CR 37570
3.780	4.606	0.472	HMSA7 S	CR 37825
3.898	4.331	0.276	HMSA7 V	CR 38883
4.134	4.724	0.433	HMSA7 V	CR 41401
4.400	5.230	0.375	HMSA7 P	CR 44000
4.811	5.543	0.472	HMSA7 V	CR 48046
10.000	11.000	0.375	HMS4 R	CR 100042
12.750	13.625	0.563	HMSA7 R	CR 127540

Radial shaft seals

CRS1, CRSH1, CRSA1 and CRSHA1 seals

All CRS seals are designed with a metal case and a conventional spring-loaded sealing lip. Some of them have a sealant on the outside diameter to compensate for imperfections in the housing bore.

CRS1: Seal with a single steel case, a conventional sealing lip and a carbon steel garter spring.

CRSA1: Seal with a single steel case, a conventional sealing lip, a carbon steel garter spring and an auxiliary, contacting lip.

CRSH1: Seal with a double steel case, a conventional sealing lip and a carbon steel garter spring.

CRSHA1: Seal with a double steel case, a conventional sealing lip, a carbon steel garter spring and an auxiliary, contacting lip.

CRS seals are available with sealing lips made of nitrile rubber for general-purpose applications and of fluoro rubber, providing improved high temperature and chemical resistance.

See **matrix 1** on **pages 90** and **91** for permissible operating conditions.

CRS1



CRSH1



CRSA1



CRSHA1



Radial shaft seals – CRS1, CRSH1, CRSA1 and CRSHA1 – metric dimensions
 d_1 12 – 37 mm

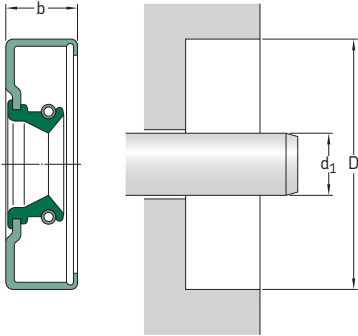

Please see pages 74 to 76 for housing bore requirements.

Dimensions Shaft	Bore	Nominal seal width	Design and lip material	Designation
d_1	D	b		
mm.			–	–
12	20	5	CRSA1 R	CR 12×20×5 CRSA1 R
13	28	7	CRS1 R	CR 13×28×7 CRS1 R
19	37	10	CRS1 V	CR 19×37×10 CRS1 V
20	30	5	CRS1 R	CR 20×30×5 CRS1 R
	30	7	CRS1 V	CR 20×30×7 CRS1 V
	32	7	CRS1 V	CR 20×32×7 CRS1 V
	42	7	CRS1 V	CR 20×42×7 CRS1 V
22	32	7	CRS1 V	CR 22×32×7 CRS1 V
24	38	10	CRS1 R	CR 24×38×10 CRS1 R
25	32	7	CRSA1 R	CR 25×32×7 CRSA1 R
	47	10	CRSA1 V	CR 25×47×10 CRSA1 V
	52	7	CRS1 R	CR 25×52×7 CRS1 R
26	35	7	CRS1 R	CR 26×35×7 CRS1 R
	42	8	CRS1 R	CR 26×42×8 CRS1 R
27	37	7	CRS1 V	CR 27×37×7 CRS1 V
	41	10	CRSH1 R	CR 27×41×10 CRSH1 R
28	62	12	CRSH1 R	CR 28×62×12 CRSH1 R
30	45	8	CRS1 V	CR 30×45×8 CRS1 V
	52	9	CRSH1 R	CR 30×52×9 CRSH1 R
32	46	8	CRS1 R	CR 32×46×8 CRS1 R
34	52	10	CRS1 R	CR 34×52×10 CRS1 R
	54	11	CRS1 R	CR 34×54×11 CRS1 R
35	64	8	CRSA1 P	CR 35×64×8 CRSA1 P
	65	12	CRSA1 R	CR 35×65×12 CRSA1 R
36	46	9	CRS1 R	CR 36×46×9 CRS1 R
	56	10	CRS1 R	CR 36×56×10 CRS1 R
37	55	10	CRSH1 R	CR 37×55×10 CRSH1 R

Radial shaft seals – CRS1, CRSH1, CRSA1 and CRSHA1 – metric dimensions d₁ 40 – 260 mm

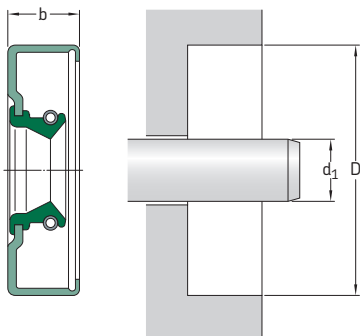

Please see **pages 74 to 76** for housing bore requirements.

Dimensions		Nominal seal width b	Design and lip material	Designation
Shaft	Bore			
d ₁	D			
mm			–	–
40	55	10	CRS1 R	CR 40×55×10 CRS1 R
	60	10	CRSA1 R	CR 40×60×10 CRSA1 R
42	62	10	CRS1 R	CR 42×62×10 CRS1 R
43	62	10	CRSH1 R	CR 43×62×10 CRSH1 R
45	58	9	CRSA1 R	CR 45×58×9 CRSA1 R
	62	7	CRSA1 R	CR 45×62×7 CRSA1 R
48	70	9	CRSA1 R	CR 48×70×9 CRSA1 R
50	62	7	CRS1 R	CR 50×62×7 CRS1 R
	62	10	CRS1 R	CR 50×62×10 CRS1 R
	85	13	CRSH1 R	CR 50×85×13 CRSH1 R
54	72	10	CRSA1 R	CR 54×72×10 CRSA1 R
	80	10	CRSH1 R	CR 54×80×10 CRSH1 R
57	72	10	CRSH1 R	CR 57×72×10 CRSH1 R
58	85	13	CRSH1 R	CR 58×85×13 CRSH1 R
59	75	10	CRSA1 R	CR 59×75×10 CRSA1 R
60	70	7	CRS1 R	CR 60×70×7 CRS1 R
	78	9	CRS1 R	CR 60×78×9 CRS1 R ¹⁾
	80	10	CRSHA1 R	CR 60×80×10 CRSHA1 R
	90	10	CRSH1 R	CR 60×90×10 CRSH1 R
62	75	10	CRS1 R	CR 62×75×10 CRS1 R
66	80	8,9	CRSHA1 R	CR 66×80×9 CRSHA1 R
	85	10	CRSHA1 R	CR 66×85×10 CRSHA1 R
	90	13	CRSH1 R	CR 66×90×13 CRSH1 R
68	85	10	CRS1 R	CR 68×85×10 CRS1 R
74	100	13	CRSH1 R	CR 74×100×13 CRSH1 R

¹⁾ Sealant on outside diameter

Dimensions Shaft d_1	Bore D	Nominal seal width b	Design and lip material	Designation
mm			–	–
75	115	13	CRSH1 R	CR 75×115×13 CRSH1 R
80	100 125	13 13	CRSA1 R CRSH1 R	CR 80×100×13 CRSA1 R CR 80×125×13 CRSH1 R
85	100	9	CRS1 R	CR 85×100×9 CRS1 R
88	110	13	CRSH1 R	CR 88×110×13 CRSH1 R
90	125	13	CRSH1 R	CR 90×125×13 CRSH1 R
95	110	9	CRS1 R	CR 95×110×9 CRS1 R
100	120	13	CRSH1 R	CR 100×120×13 CRSH1 R
105	125	12	CRS1 R	CR 105×125×12 CRS1 R
107	123	11	CRSA1 R	CR 107×123×11 CRSA1 R
108	130	13	CRSH1 R	CR 108×130×13 CRSH1 R
113	140	13	CRSH1 R	CR 113×140×13 CRSH1 R
115	160	15	CRSH1 R	CR 115×160×15 CRSH1 R
120	150	15	CRSH1 R	CR 120×150×15 CRSH1 R
125	146	14	CRSA1 P	CR 125×146×14 CRSA1 P
126	147	11	CRSA1 R	CR 126×147×11 CRSA1 R
130	150 150 155 160 160 165	10 14 10 13 13 13	CRSA1 R CRSA1 R CRSH1 R CRS1 R CRSA1 R CRSH1 R	CR 130×150×10 CRSA1 R CR 130×150×14 CRSA1 R CR 130×155×10 CRSH1 R CR 130×160×13 CRS1 R CR 130×160×13 CRSA1 R CR 130×165×13 CRSH1 R
135	160 170	13 15	CRSH1 R CRSH1 R	CR 135×160×13 CRSH1 R CR 135×170×15 CRSH1 R
138	152	12	CRSA1 R	CR 138×152×12 CRSA1 R
145	164 175	14 14	CRSA1 R CRS1 R	CR 145×164×14 CRSA1 R CR 145×175×14 CRS1 R
150	170 180 200	15 13 15	CRSH1 R CRSH1 R CRSH1 R	CR 150×170×15 CRSH1 R CR 150×180×13 CRSH1 R CR 150×200×15 CRSH1 R
154	175	13	CRSA1 R	CR 154×175×13 CRSA1 R
160	185	13	CRSA1 V	CR 160×185×13 CRSA1 V
168	200	15	CRSH1 R	CR 168×200×15 CRSH1 R
170	190	15	CRSH1 R	CR 170×190×15 CRSH1 R
180	200 215 220	12 16 16	CRS1 R CRS1 R CRSA1 R	CR 180×200×12 CRS1 R CR 180×215×16 CRS1 R CR 180×220×16 CRSA1 R
190	215	16	CRSH1 R	CR 190×215×16 CRSH1 R
195	230	15	CRSH1 R	CR 195×230×15 CRSH1 R
200	250	15	CRSH1 R	CR 200×250×15 CRSH1 R
260	300	20	CRS1 R	CR 260×300×20 CRS1 R

Radial shaft seals – CRS1, CRSH1, CRSA1 and CRSHA1 – inch dimensions

d_1 0.531 – 2.008 in.

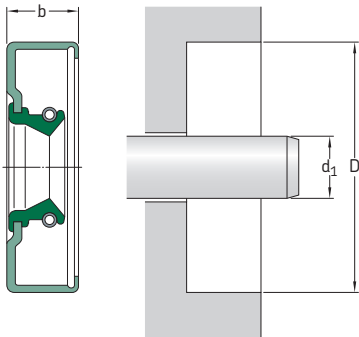

Please see pages 74 to 76 for housing bore requirements.

Dimensions Shaft	Bore	Nominal seal width	Design and lip material	Designation
d_1	D	b		
in.			–	–
0.531	1.124	0.313	CRSA1 R	CR 5334
0.594	1.250 1.375	0.313 0.313	CRSA1 R CRSA1 R	CR 5950 CR 5966¹⁾
0.669	1.339	0.311	CRSA1 P	CR 6992
0.709	1.339	0.315	CRSA1 P	CR 7089
0.781	1.752	0.313	CRSHA1 R	CR 8213
0.844	1.828	0.313	CRSA1 R	CR 8485
0.945	1.575	0.315	CRS1 R	CR 9515
0.969	2.048	0.375	CRS1 R	CR 9688¹⁾
1.125	2.835 2.875	0.375 0.469	CRSA1 R CRSH1 R	CR 11405¹⁾ CR 11410¹⁾
1.156	2.125	0.438	CRSH1 R	CR 11566¹⁾
1.219	2.000	0.438	CRSH1 R	CR 12131¹⁾
1.250	2.561 2.713 3.156	0.500 0.469 0.500	CRSH1 R CRSH1 R CRSH1 R	CR 12655 CR 12660¹⁾ CR 12678
1.301	2.000	0.438	CRSA1 P	CR 12905
1.313	1.874 2.000 2.106 2.996	0.375 0.313 0.375 0.500	CRSA1 R CRSA1 R CRSA1 R CRSH1 R	CR 13027¹⁾ CR 13037¹⁾ CR 13084¹⁾ CR 13275¹⁾
1.328	2.312	0.433	CRS1 R	CR 13419¹⁾
1.362	2.191	0.250	CRS1 P	CR 13500

¹⁾ Sealant on outside diameter

Dimensions Shaft d ₁	Bore D	Nominal seal width b	Design and lip material	Designation
in.			–	–
1.375	2.750 3.000 3.125 3.350	0.500 0.500 0.500 0.469	CRSH1 R CRSHA1 R CRSH1 R CRSH1 R	CR 13906¹⁾ CR 13937 CR 13936 CR 13934¹⁾
1.399	2.292 2.292	0.469 0.500	CRSA1 R CRSA1 R	CR 13992¹⁾ CR 13990¹⁾
1.414	2.250	0.250	CRSHA1 R	CR 14035¹⁾
1.469	2.374	0.375	CRSA1 R	CR 14641¹⁾
1.491	2.191	0.250	CRSA1 R	CR 14780
1.500	2.996 3.000	0.500 0.375	CRSH1 R CRSA1 R	CR 15240 CR 15241
1.524	2.374	0.500	CRSH1 R	CR 15343
1.563	2.716	0.469	CRSH1 R	CR 15748¹⁾
1.618	2.575	0.500	CRSA1 R	CR 16404¹⁾
1.625	2.437 2.835 3.062 3.251	0.469 0.469 0.500 0.500	CRSHA1 R CRSH1 R CRSH1 R CRSH1 R	CR 16121 CR 16386 CR 16431¹⁾ CR 16440¹⁾
1.656	2.502	0.500	CRSH1 R	CR 16532¹⁾
1.688	2.374 2.835	0.313 0.469	CRSA1 R CRSA1 R	CR 16669 CR 16960
1.705	3.084	0.500	CRS1 R	CR 17053
1.719	2.623	0.500	CRSH1 R	CR 17136¹⁾
1.750	2.328 3.154 3.937	0.438 0.313 0.313	CRS1 R CRS1 R CRSA1 R	CR 17257 CR 17726 CR 17771¹⁾
1.781	2.750 2.758	0.500 0.500	CRSH1 R CRSH1 R	CR 17847 CR 17851¹⁾
1.844	2.502 2.750	0.375 0.375	CRSA1 R CRSA1 R	CR 18412¹⁾ CR 18446¹⁾
1.875	3.125	0.313	CRSA1 R	CR 18879¹⁾
1.889	3.110	0.688	CRSA1 P	CR 18983
1.890	2.874	0.276	CRSA1 P	CR 18979
1.906	3.189	0.313	CRSA1 P	CR 19062
1.938	2.762 2.825 3.751	0.500 0.500 0.500	CRSA1 R CRSH1 P CRSH1 R	CR 19273¹⁾ CR 19274 CR 19466¹⁾
1.969	2.638 2.686 2.742 2.875	0.354 0.500 0.500 0.469	CRSA1 R CRSH1 R CRSH1 P CRSH1 R	CR 19628 CR 19615 CR 19620 CR 19643
2.008	2.953	0.354	CRSA1 P	CR 20012

¹⁾ Sealant on outside diameter

Radial shaft seals – CRS1, CRSH1, CRSA1 and CRSHA1 – inch dimensions
 d_1 2.063 – 7.000 in.

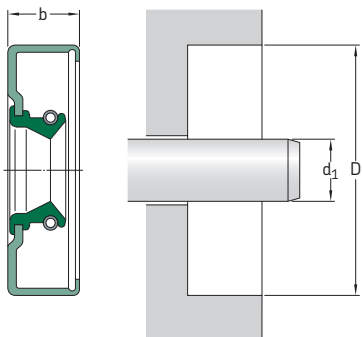

Please see **pages 74 to 76** for housing bore requirements.

Dimensions Shaft	Bore	Nominal seal width b	Design and lip material	Designation
d_1	D			
in.			–	–
2.063	2.875	0.375	CRSA1 R	CR 550085¹⁾
2.125	3.623	0.469	CRSA1 P	CR 21379
2.145	3.188	0.469	CRSH1 R	CR 21538
2.188	3.623	0.500	CRSHA1 R	CR 21950
2.432	3.070	0.227	CRSA1 P	CR 24110
2.563	3.500	0.500	CRSHA1 P	CR 25587
2.648	3.812	0.500	CRS1 R	CR 26877
2.750	4.125 4.125	0.438 0.563	CRS1 P CRSA1 R	CR 27576¹⁾ CR 27577
2.875	3.434	0.294	CRSA1 R	CR 28646¹⁾
2.913	3.543	0.394	CRS1 P	CR 29105
3.125	3.936	0.512	CRSA1 V	CR 31144¹⁾
3.250	3.876 4.125	0.375 0.563	CRSA1 V CRSH1 R	CR 32332¹⁾ CR 32362¹⁾
3.298	4.125	0.563	CRSA1 R	CR 32815¹⁾
3.469	4.626	0.625	CRSA1 R	CR 34700
3.500	5.751	0.563	CRSH1 R	CR 35111¹⁾
3.504	4.173	0.354	CRSA1 V	CR 35120
3.813	4.999 5.251	0.469 0.469	CRSH1 R CRSH1 R	CR 38160 CR 38220¹⁾
3.875	5.501 5.751	0.500 0.563	CRSHA1 R CRSH1 R	CR 38749¹⁾ CR 38810

¹⁾ Sealant on outside diameter

Dimensions Shaft d_1	Bore D	Nominal seal width b	Design and lip material	Designation
in.			–	–
3.898	4.680	0.370	CRSA1 VR	CR 38880
4.188	4.999 5.251 5.751	0.469 0.469 0.500	CRSHA1 R CRSH1 R CRSHA1 R	CR 41751 CR 41761 CR 41833
4.313	5.751	0.500	CRSH1 R	CR 43231
4.563	5.751 6.250	0.500 0.500	CRSHA1 R CRSH1 R	CR 45550 CR 45560
5.000	7.000 7.500	0.500 0.500	CRSHA1 R CRSHA1 R	CR 50185 CR 50195
5.125	6.500	0.500	CRSHA1 R	CR 51276
5.313	6.500	0.500	CRSHA1 R	CR 53151
5.375	6.374 6.499	0.500 0.563	CRSHA1 R CRSH1 R	CR 53688¹⁾ CR 53692
5.500	6.626 6.876 7.501	0.563 0.563 0.563	CRSHA1 R CRSHA1 R CRSH1 R	CR 54949 CR 55157 CR 55179
5.750	6.876 7.126 7.502	0.563 0.563 0.563	CRSHA1 R CRSHA1 R CRSHA1 R	CR 57519 CR 57578 CR 57584
6.000	7.002	0.500	CRSHA1 R	CR 60006¹⁾
6.062	6.772	0.551	CRSA1 R	CR 60620
6.125	7.502	0.563	CRSHA1 R	CR 61248¹⁾
6.188	7.500	0.563	CRSH1 P	CR 61740
7.000	8.375	0.625	CRSHA1 R	CR 70034

¹⁾ Sealant on outside diameter

Radial shaft seals

PTFE radial shaft seals

Radial shaft seals with one or more PTFE sealing lip(s) are designed to withstand aggressive environments, high temperatures, high pressures and dry running that traditional radial shaft seals made of elastomeric sealing lip materials cannot withstand. Many of the PTFE compounds are FDA approved. Main advantages of PTFE seals include:

- High chemical resistance
- Withstand speeds up to 30 m/s (5 900 ft/min)
- Wide operating temperature range, -70 to +250 °C (-95 to +480 °F)
- Withstand pressures up to 3,5 MPa (500 psi)
- Withstand dry running

Assortment

The profiles shown below are a selection of the most commonly used SKF seal designs with sealing lips made of PTFE. They can be installed in existing housing grooves where traditional radial seals are used, provided that the grooves are manufactured in accordance with international standards.

There are two main executions of PTFE seals: those with a metal case and those without a metal case. The metal case can be made of steel, aluminium or any of the stainless steel materials SS 304, SS 316 and SS 316 TI. The PTFE material should be selected based on the needs of the application.

PTFE seals without a metal case can be designed with an O-ring in the outside diameter groove to provide static sealing ability. Both the PTFE and O-ring material can be selected to meet the demands of different operating conditions, e.g. in the food industry to enable disassembly of the equipment for cleaning.

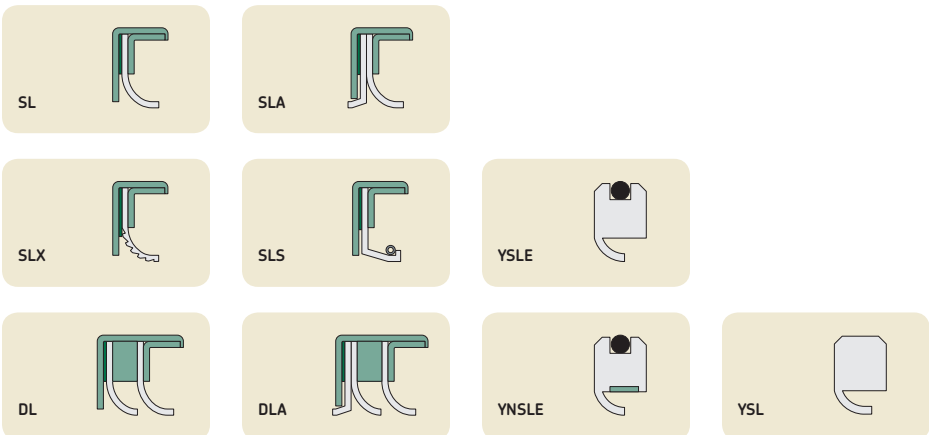

PTFE materials

The selection of seal materials typically requires a compromise between advantages and disadvantages. There are hundreds of different PTFE materials with a variety of fillers. Common fillers include glass fibre, carbon, graphite, molybdenum disulphide, metal oxides and various polymers. Each possesses different properties, appropriate for different applications and service conditions. Common to all filled PTFE materials are their improved resistance to wear and deformation.

Unfilled PTFE provides, in most cases, a lower coefficient of friction than a filled PTFE material and the lowest degree of wear of the seal counterface. However, a sealing lip made of an unfilled PTFE material has limited resistance to wear and deformation under load.

The PTFE materials that SKF most often recommends are listed in **table 14** on **page 180**. In addition to PTFE-based compounds, SKF also offers radial shaft seals in other modified plastics, some of which are listed in **table 15** on **page 181**.

Selecting the appropriate material for the metal case and the O-ring(s) is also of significant importance to achieving satisfactory sealing performance. Contact SKF for more information.

Installation

Special care must be taken during handling and installation of PTFE seals. For more information, refer to **pages 85** and **86**.

Size range and availability

The majority of PTFE radial shaft seals from SKF are made to order to meet the demands of each application. There are, however, certain standard sizes within the ranges of approximately 6 to 200 mm (*0.250 to 8 in.*) shaft diameter and approximately 16 to 230 mm (*0.630 to 9 in.*) bore diameter. Contact SKF for more information regarding designs and sizes.

Radial shaft seals

Table 14

Material family	Description	Shaft hardness recommended ¹⁾
PTFE, unfilled	"Virgin" PTFE. FDA approved. Low-friction material. Used for general non-pressure applications on shafts with low hardness value. Excellent for cryogenics.	A
PTFE + glass	FDA approved. Glass can be in the form of beads or fibres. Glass is exceptionally strong and prolongs the life of the base PTFE. Due to its inherent hardness, it also adds an abrasive property and is not recommended on low-hardness shafts.	C
PTFE + MoS₂	Molybdenum disulphide (MoS ₂) adds wear resistance to the base PTFE. Not as abrasive as glass.	C
PTFE + glass + MoS₂	Improved elongation characteristics and less abrasive to running surfaces compared to PTFE + glass.	C
PTFE + carbon	Carbon can be in the form of various grades of fibres or graphite powder, either natural or synthetic. Carbon is an excellent natural lubricant and provides wear resistance to enhance the low-friction base PTFE material. Increased percentage of carbon will increase the wear, creep, and extrusion resistance and improve performance in steam and chemical service at elevated temperatures and pressures.	A, B, C
PTFE + carbon + MoS₂	Excellent wear rate in non-lubricated services at high temperatures.	B, C
PTFE + bronze	Suitable for high-speed dynamic sealing of hydraulic media. Should not be used in chemical service, which could attack the bronze.	
PTFE + bronze + MoS₂	High degree of wear and extrusion resistance in high-pressure applications.	
PTFE + polymer	Polymers, such as polyoxybenzoate, polyimide and many others improve creep and wear resistance.	A, B, C
PTFE + organic pigment	FDA and/or USDA 3A approved.	

¹⁾ Material selection recommendations for counterface hardness ratings (Rockwell C scale) combined with surface speed. For material selection, please see **table 16**

Table 15

Modified plastic materials

UHMWPE	Ultra-high molecular weight polyethylene. Significantly improved wear and abrasion resistance over PTFE-based materials in non-lubricated or abrasive media. FDA and USDA 3A approved. Fair media compatibility, limited to approximately 90 °C (195 °F).
Nylon	Improved strength, limited media compatibility and temperature resistance. Hydroscopic. Used for plain bearings, bushings, back-up rings and some seals.
POM	Polyoxymethylene (a.k.a. polyacetal or just acetal). Similar to nylon but with significantly reduced water-absorption properties. Some grades are FDA and USDA 3A compliant. Typically used for plain bearings, bushings, and back-up rings.
Ertalylte	Similar to POM but offers improved media compatibility and improved wear resistance.
PEEK	Polyetheretherketone. Similar strength properties as nylon and POM but with very good media compatibility and significantly better temperature properties. Some grades are FDA and USDA 3A compliant. Used for plain bearings, bushings, back-up rings and some seals.
PPS	Polyphenylene sulphide. Similar strength properties and chemical compatibility as PEEK-based compounds but offers improved wear resistance. Has better temperature capabilities than nylon or POM materials but not as good as PEEK. Adding fillers can create a "bearing-grade" PPS for high-performance applications.
PA	Polyamide. Exceptional mechanical, thermal and chemical resistance properties.



Table 16

Material selection with shaft hardness + velocity

Surface speed	< 30 HRC	45 HRC	≥ 58 HRC
Low	A or B	A, B, C	A, B, C
Medium	A	A, B	A, B, C
High	A	A, B	A, B

Radial shaft seals

HM and TL seals for grease lubricated applications

SKF offers an extensive assortment of radial shaft seals for less demanding grease lubricated applications operating at moderate speeds. The majority of these seals are designed without a spring. The seals are generally installed with the sealing lip facing outward to provide maximum exclusion ability. Typical applications are grease lubricated agriculture machinery. The illustrations below show the most commonly used designs within this assortment from SKF. Contact SKF for more information on available designs.

See **matrix 1** on **pages 90** and **91** for permissible operating conditions, valid for both HM and TL seals.



Radial shaft seals – HM and TL seals – metric dimensions

d_1 6 – 22 mm

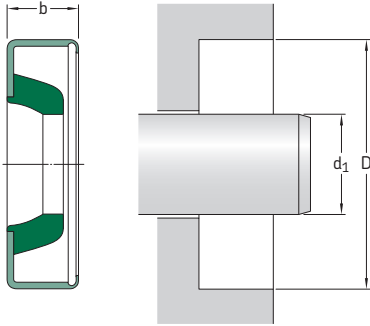

2.7

Please see pages 74 to 76 for housing bore requirements.

Dimensions Shaft	Bore	Nominal seal width	Design and lip material	Designation
d_1	D	b		
mm			–	–
6	12	2	HM3 R	CR 6×12×2 HM3 R
8	12	3	HM4 R	CR 8×12×3 HM4 R
9	13	3	HM4 R	CR 9×13×3 HM4 R
10	14	3	HM4 R	CR 10×14×3 HM4 R
	16	4	HM102 R	CR 10×16×4 HM102 R
12	16	3	HM4 R	CR 12×16×3 HM4 R
	18	3	HM4 R	CR 12×18×3 HM4 R
	19	3	HM4 R	CR 12×19×3 HM4 R
	22	4	HM4 R	CR 12×22×4 HM4 R
14	20	3	HM4 R	CR 14×20×3 HM4 R
	22	3	HM4 R	CR 14×22×3 HM4 R
15	21	3	HM4 R	CR 15×21×3 HM4 R
	23	3	HM4 R	CR 15×23×3 HM4 R
	25	5	HMA10 R	CR 15×25×5 HMA10 R
16	22	3	HM4 R	CR 16×22×3 HM4 R
	22	4	HM4 R	CR 16×22×4 HM4 R
	24	4	HM102 R	CR 16×24×4 HM102 R
17	23	3	HM4 R	CR 17×23×3 HM4 R
18	24	3	HM4 R	CR 18×24×3 HM4 R
	26	4	HMA1 R	CR 18×26×4 HMA1 R
19	27	4	HM4 R	CR 19×27×4 HM4 R
20	26	4	HM4 R	CR 20×26×4 HM4 R
	28	4	HM4 R	CR 20×28×4 HM4 R
22	28	4	HM1 R	CR 22×28×4 HM1 R
	28	4	HMA10 R	CR 22×28×4 HM10 R
	30	4	HM4 R	CR 22×30×4 HM4 R
	35	5	HM14 R	CR 22×35×5 HM14 R

Radial shaft seals – HM and TL seals – metric dimensions

d_1 23 – 65 mm

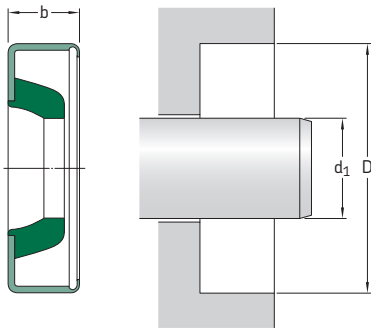

Please see **pages 74 to 76** for housing bore requirements.

Dimensions Shaft	Bore	Nominal seal width b	Design and lip material	Designation
d_1	D	b		
mm			–	–
23	32 35	5,50 6	HM1 R HMA10 R	CR 23x32x6 HM1 R CR 23x35x6 HMA10 R
24	32	4	HM4 R	CR 24x32x4 HM4 R
25	32 33 35	4 4 4	HM4 R HM4 R HM4 R	CR 25x32x4 HM4 R CR 25x33x4 HM4 R CR 25x35x4 HM4 R
26	34	4	HM4 R	CR 26x34x4 HM4 R
28	35 35 37	4 6 4	HM4 R HM102 R HM4 R	CR 28x35x4 HM4 R CR 28x35x6 HM102 R CR 28x37x4 HM4 R
30	37 40	4 4	HM4 R HM4 R	CR 30x37x4 HM4 R CR 30x40x4 HM4 R
32	42	4	HM4 R	CR 32x42x4 HM4 R
35	42 45 47	4 4 5	HM4 R HM4 R HM4 R	CR 35x42x4 HM4 R CR 35x45x4 HM4 R CR 35x47x5 HM4 R
37	47	4	HM4 R	CR 37x47x4 HM4 R
38	48	4	HM4 R	CR 38x48x4 HM4 R
40	47 50 52 53 62	4 4 5 5 10	HM4 R HM4 R HM4 R HMA76 R HMA10 R	CR 40x47x4 HM4 R CR 40x50x4 HM4 R CR 40x52x5 HM4 R CR 40x53x5 HMA76 R CR 40x62x10 HMA10 R
42	52 55 64	4 6 6	HM4 R HM1 R HMA1 R	CR 42x52x4 HM4 R CR 42x55x6 HM1 R CR 42x64x6 HMA1 R

Dimensions			Design and lip material	Designation
Shaft	Bore	Nominal seal width		
d_1	D	b		
mm			–	–
45	52	4	HM4 R	CR 45×52×4 HM4 R
	55	4	HM4 R	CR 45×55×4 HM4 R
	72	8	HMA22 R	CR 45×72×8 HMA22 R
47	72	6	HMA85 R	CR 47×72×6 HMA85 R
48	58	4	HM4 R	CR 48×58×4 HM4 R
50	60	6	HMA10 R	CR 50×60×6 HMA10 R
	62	5	HM4 R	CR 50×62×5 HM4 R
62	78	7	HMA8 R	CR 62×78×7 HMA8 R
65	75	8	HM102 R	CR 65×75×8 HM102 R

Radial shaft seals – HM and TL seals – inch dimensions

d_1 0.188 – 0.750 in.

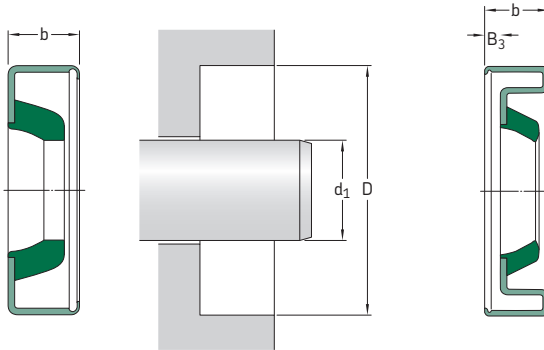

Please see pages 74 to 76 for housing bore requirements.

Dimensions Shaft	Bore	Nominal seal width b	Clearance	Design and lip material	Designation	
d_1	D	b	B_3			
in.				–	–	
0.188	0.500	0.125		HM14 R	CR 1850	
0.250	0.499	0.188		HM14 R	CR 2450	
	0.499	0.188		HMA14 V	CR 2452	
	0.562	0.188		HM14 R	CR 2470¹⁾	
	0.626	0.250		HM14 R	CR 2490	
	0.749	0.188		HM14 R	CR 2560	
0.313	0.500	0.125		HM4 R	CR 3044	
	0.626	0.156		HM14 R	CR 3060¹⁾	
	0.626	0.156		HM14 V	CR 3061	
	0.626	0.203		HM1 R	CR 3050¹⁾	
	0.633	0.141		HM14 R	CR 3080	
	0.749	0.250		HM14 R	CR 3140	
	0.750	0.250		HM3 R	CR 3141	
	0.862	0.250		HM14 R	CR 3086	
	0.375	0.562	0.093		HM3 V	CR 535835
		0.563	0.094		HM3 R	CR 3621
0.628		0.197		HMA10 P	CR 3632	
0.687		0.156		HM14 R	CR 3645¹⁾	
0.749		0.250		HM14 R	CR 3683	
0.875		0.250		HM14 R	CR 3727	
0.404	0.620	0.188		HM14 R	CR 4010	
	0.862	0.250		HM14 R	CR 4012	
0.438	0.836	0.188		HM14 R	CR 4231	
	0.879	0.180		HM8 R	CR 4256	
	0.999	0.250		HM14 R	CR 4340	
0.469	0.836	0.188		HM14 P	CR 4623	
	0.875	0.219		HM14 R	CR 4628	
0.500	0.687	0.093		HM3 V	CR 538545	
	0.688	0.094		HM3 R	CR 4911	
	0.750	0.125		HM14 R	CR 4912¹⁾	

¹⁾ SKF Bore Tite Coating

Dimensions Shaft	Bore	Nominal seal width b	Clearance B ₃	Design and lip material	Designation
d ₁	D				
in.				–	–
0.500 cont.	0.820	0.156		HM14 R	CR 4914 ¹⁾
	0.843	0.250		HM14 R	CR 4923 ¹⁾
	0.875	0.125		HM14 R	CR 4925
	0.875	0.250		HM14 R	CR 4938
	0.999	0.188		HM14 R	CR 4950 ¹⁾
	0.999	0.250		HM14 R	CR 4990 ¹⁾
	1.124	0.250		HM14 R	CR 5085 ¹⁾
0.551	1.124	0.203		HM21 R	CR 5399 ¹⁾
0.563	0.750	0.094		HM3 R	CR 5500
	0.875	0.188		HM14 R	CR 5522 ¹⁾
	0.999	0.219		HM14 R	CR 5569 ¹⁾
	1.124	0.250		HM14 R	CR 5685
0.594	1.124	0.250		HM14 R	CR 5946 ¹⁾
0.624	1.131	0.188		HM14 R	CR 6243 ¹⁾
0.625	0.812	0.094		HM3 R	CR 6105
	0.813	0.094		HM3 V	CR 6106
	0.875	0.125		HM R	CR 532444
	0.933	0.188		HM14 R	CR 6125 ¹⁾
	0.933	0.188		HM14 V	CR 6126 ¹⁾
	0.937	0.188		HM14 R	CR 6130 ¹⁾
	1.000	0.125		HM14 P	CR 6152 ¹⁾
	1.000	0.125		HM14 R	CR 6153
	1.063	0.250		HM14 R	CR 6158 ¹⁾
	1.124	0.250		HM14 R	CR 6225 ¹⁾
	1.125	0.250		HM14 R	CR 531074 ²⁾
	1.250	0.250		HM14 R	CR 6323 ¹⁾
	1.259	0.250		HM14 R	CR 6330 ¹⁾
	1.375	0.250		HM14 R	CR 6370 ¹⁾
0.669	1.250	0.250		HM14 R	CR 6806 ¹⁾
0.688	0.999	0.188		HM14 R	CR 6720 ¹⁾
	1.124	0.250		HM14 R	CR 6759 ¹⁾
	1.187	0.125		HM14 R	CR 6762 ¹⁾
	1.375	0.125		HM14 R	CR 6915 ¹⁾
	1.375	0.250		HM14 R	CR 6920 ¹⁾
0.750	0.999	0.125		HM14 R	CR 7410
	1.000	0.125		HM14 D	CR 7408 ¹⁾
	1.000	0.125		HM3 V	CR 535909
	1.004	0.156		HM8 R	CR 7409
	1.006	0.125		HM14 R	CR 7411 ¹⁾
	1.012	0.226		HMA3SPL R	CR 7535
	1.031	0.313		HMA6 R	CR 7412
	1.062	0.188		HM14 R	CR 7413
	1.124	0.156		HM14 R	CR 7415 ¹⁾
	1.187	0.156		HM14 R	CR 7421
	1.249	0.250		HM14 R	CR 530716 ³⁾
	1.250	0.250		HM14 R	CR 7464 ¹⁾
	1.259	0.250		HM14 R	CR 7477 ¹⁾

1) SKF Bore Tite Coating

2) Stainless steel spring

3) Stainless steel case

Radial shaft seals – HM and TL seals – inch dimensions

d_1 0.750 – 1.250 in.

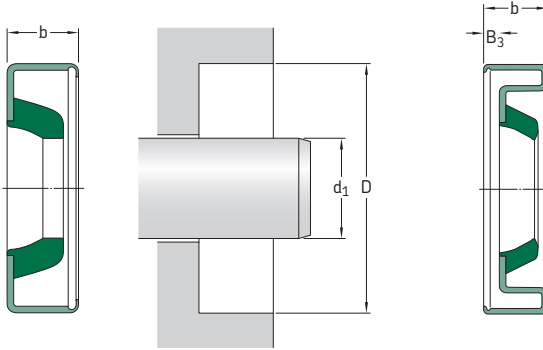

Please see pages 74 to 76 for housing bore requirements.

Dimensions		Nominal seal width b	Clearance B_3	Design and lip material	Designation
Shaft d_1	Bore D				
in.				–	–
0.750	1.375	0.250		HM14 R	CR 7536
	1.375	0.250		HM14 P	CR 7537
	1.437	0.250		HM14 R	CR 7550¹⁾
	1.499	0.250		HM14 R	CR 7571¹⁾
0.781	1.375	0.197		HM14 R	CR 7831¹⁾
0.813	1.063	0.125		HM3 R	CR 8009
0.875	1.125	0.125		HM14 R	CR 8620
	1.125	0.125		HM14 V	CR 8619¹⁾
	1.246	0.188		HM14 R	CR 8625¹⁾
	1.251	0.188		HM14 R	CR 8627
	1.251	0.188		HM3 R	CR 8631²⁾
	1.255	0.188		HM14 R	CR 8632¹⁾
	1.308	0.250		HM14 R	CR 8637¹⁾
	1.312	0.250		HM14 R	CR 8645¹⁾
	1.375	0.188		HM14 R	CR 8677¹⁾
	1.437	0.250		HM14 R	CR 8690¹⁾
	1.499	0.250		HM21 R	CR 8741¹⁾
	1.562	0.250		HM14 R	CR 8761
	1.575	0.250		HM14 R	CR 8772
	1.624	0.188		HM8 R	CR 8802
0.938	1.375	0.250		HM14 R	CR 9243¹⁾
	1.499	0.250		HM14 R	CR 9298¹⁾
	1.734	0.250		HM14 R	CR 9354¹⁾
1.000	1.250	0.125		HM14 R	CR 9815¹⁾
	1.312	0.125		HM14 R	CR 9818¹⁾
	1.375	0.188		HM14 R	CR 9820¹⁾
	1.437	0.250		HM14 R	CR 9835¹⁾
	1.499	0.188		HM14 R	CR 9859¹⁾

¹⁾ SKF Bore Tite Coating

²⁾ Stainless steel case

Dimensions Shaft	Bore	Nominal seal width b	Clearance	Design and lip material	Designation
d ₁	D	b	B ₃		
in.				–	–
1.000 cont.	1.510	0.219		HM21 R	CR 9853 ¹⁾
	1.561	0.250		HM14 R	CR 9900 ¹⁾
	1.575	0.250		HM14 R	CR 9903 ¹⁾
	1.624	0.250		HM14 R	CR 9932 ¹⁾
	1.752	0.250		HM21 R	CR 9995 ¹⁾
	1.781	0.250		HM21 R	CR 530484
	1.781	0.469	0.265	HM14 R	CR 10034 ¹⁾
	1.781	0.469	0.265	HM18 R	CR 10035 ¹⁾
	1.851	0.250		HM14 R	CR 10074 ¹⁾
	1.938	0.250		HM14 R	CR 10112 ¹⁾
	2.000	0.250		HM21 R	CR 10153 ¹⁾
	2.250	0.250		HM14 R	CR 10172 ¹⁾
1.125	1.375	0.125		HM14 R	CR 11050
	1.375	0.125		HM14 V	CR 11052 ¹⁾
	1.438	0.203		HM14 R	CR 11055 ¹⁾
	1.499	0.188		HM14 R	CR 11060 ¹⁾
	1.562	0.188		HM8 R	CR 11065
	1.562	0.250		HM14 R	CR 11081
	1.624	0.250		HM21 R	CR 11130 ¹⁾
	1.750	0.250		HM14 R	CR 11150 ¹⁾
	1.781	0.250		HM21 R	CR 11161 ¹⁾
	1.781	0.469	0.265	HM18 R	CR 11164
	1.828	0.250		HM21 R	CR 11191
	1.938	0.343	0.352	HM14 R	CR 11269
2.000	0.250		HM21 R	CR 11334 ¹⁾	
2.047	0.250		HM21 R	CR 11352 ¹⁾	
1.188	2.000	0.250		HM1 R	CR 11836
1.190	1.996	0.250		HM1 R	CR 11846 ¹⁾
1.250	1.500	0.125		HM14 R	CR 12330 ¹⁾
	1.624	0.250		HM14 R	CR 12325 ¹⁾
	1.625	0.188		HM14 R	CR 11096
	1.686	0.188		HM14 R	CR 12334 ¹⁾
	1.752	0.188		HM21 R	CR 12361 ¹⁾
	1.752	0.250		HM21 R	CR 12369
	1.828	0.188		HM8 R	CR 12375
	1.874	0.250		HM21 R	CR 12379 ¹⁾
	1.968	0.438		HM14 R	CR 12398 ¹⁾
	1.968	0.469	0.254	HM18 R	CR 12399 ¹⁾
	1.979	0.250		HM21 R	CR 12407 ¹⁾
	1.979	0.406	0.200	HM18 R	CR 12411
1.980	0.406		HMA22 R	CR 12506 ¹⁾	
1.983	0.250		HM21 R	CR 12437	
2.000	0.250		HM21 R	CR 12481 ¹⁾	
2.062	0.250		HM21 R	CR 12508 ¹⁾	
2.125	0.250		HM21 R	CR 12565 ¹⁾	
2.250	0.250		HM14 R	CR 12582 ¹⁾	
2.328	0.500	0.286	HM18 R	CR 12611 ¹⁾	

¹⁾ SKF Bore Tite Coating

Radial shaft seals – HM and TL seals – inch dimensions

d_1 1.375 – 1.750 in.

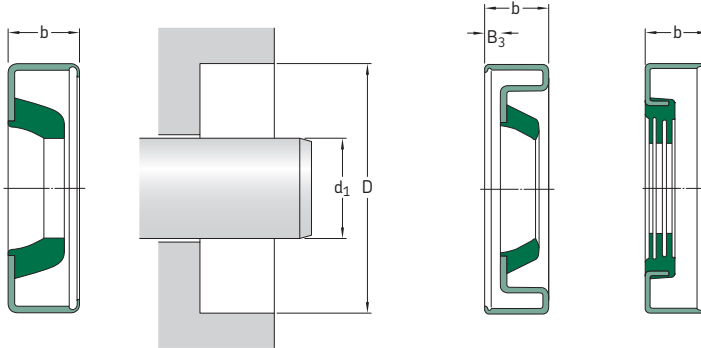

Please see pages 74 to 76 for housing bore requirements.

Dimensions Shaft	Bore	Nominal seal width b	Clearance B_3	Design and lip material	Designation
d_1	D	b	B_3		
in.				–	–
1.375	1.750	0.197	0.188	HM14 R	CR 13529
	1.750	0.197		HM14 V	CR 13509 ¹⁾
	1.834	0.188		HM8 R	CR 13533 ¹⁾
	1.874	0.188		HM14 R	CR 13543
	1.874	0.250		HM14 R	CR 13548 ¹⁾
	1.874	0.250		HM14 P	CR 13545 ¹⁾
	1.938	0.250		HM14 R	CR 13556 ¹⁾
	2.000	0.250		HM21 R	CR 13573 ¹⁾
	2.106	0.250		HM21 R	CR 13612 ¹⁾
	2.125	0.250		HM21 R	CR 13662 ¹⁾
	2.250	0.250		HM14 R	CR 13689 ¹⁾
	2.282	0.250		HM14 R	CR 13710 ¹⁾
	2.328	0.406		HM18 R	CR 13711
	2.374	0.250		HM21 R	CR 13758 ¹⁾
2.437	0.250	HM21 R	CR 13796 ¹⁾		
2.502	0.250	HM21 R	CR 13862 ¹⁾		
2.835	0.594	TL8 R	CR 13916 ¹⁾		
1.438	2.000	0.125	HM4 R	CR 14209	
	2.250	0.250	HM14 R	CR 14257 ¹⁾	
	2.437	0.250	HM21 R	CR 14359 ¹⁾	
	2.437	0.250	HM21 V	CR 564365 ¹⁾	
1.457	2.047	0.328	HMA11 R	CR 14600 ²⁾	
1.473	1.971	0.563	HMA10 R	CR 14631	
1.500	1.874	0.188	HM14 R	CR 14804	
	1.874	0.188	HM14 V	CR 14808 ¹⁾	
	1.874	0.250	HM14 R	CR 14810 ¹⁾	
	1.938	0.250	HM14 R	CR 14816 ¹⁾	
	1.983	0.188	HM14 R	CR 14840	
	1.989	0.250	HMA22 R	CR 14848 ¹⁾	

¹⁾ SKF Bore Tite Coating

²⁾ Press-fit width 0.288 in., axial auxiliary lip

Dimensions Shaft	Bore	Nominal seal width b	Clearance	Design and lip material	Designation
d ₁	D	b	B ₃		
in.				–	–
1.500 cont.	2.000	0.188		HM8 R	CR 14869
	2.000	0.250		HM14 R	CR 14857 ¹⁾
	2.250	0.250		HM21 R	CR 14960
	2.254	0.250		HM21 R	CR 14966 ¹⁾
	2.328	0.390	0.188	HM18 R	CR 14975
	2.328	0.500	0.286	HM18 R	CR 14974
	2.374	0.250		HM21 R	CR 15032 ¹⁾
	2.437	0.250		HM14 R	CR 15080 ¹⁾
	2.502	0.250		HM21 R	CR 15160 ¹⁾
	2.623	0.250		HM21 R	CR 15190
2.716	0.250		HM21 R	CR 15209 ¹⁾	
1.563	2.250	0.250		HM14 R	CR 15532 ¹⁾
	2.374	0.250		HM21 R	CR 15544 ¹⁾
	2.502	0.250		HM21 R	CR 15649 ¹⁾
	2.687	0.250		HM21 R	CR 15719 ¹⁾
1.609	1.906	0.250		HM3 R	CR 16430 ²⁾
1.625	2.125	0.250		HM14 R	CR 16055 ¹⁾
	2.250	0.250		HM21 R	CR 16065 ¹⁾
	2.328	0.438	0.235	HM18 R	CR 16069 ¹⁾
	2.328	0.438		TL7 R	CR 16064
	2.374	0.250		HM21 R	CR 16092 ¹⁾
	2.375	0.250		HM14 R	CR 16095
	2.437	0.250		HM21 R	CR 16168 ¹⁾
	2.502	0.250		HM21 R	CR 16270 ¹⁾
	2.562	0.250		HM21 R	CR 16284 ¹⁾
	2.562	0.438	0.210	HM18 R	CR 16289 ¹⁾
2.623	0.250		HM21 R	CR 16322 ¹⁾	
2.750	0.250		HM21 R	CR 16362 ¹⁾	
2.781	0.313		HM14 R	CR 16384 ¹⁾	
1.660	2.440	0.594		HM11 R	CR 16520
1.688	2.328	0.500	0.286	HM18 R	CR 16667
	2.502	0.281		HM21 R	CR 16743 ¹⁾
	2.562	0.250		HM21 R	CR 16754 ¹⁾
1.750	2.250	0.188		HM14 R	CR 17240 ¹⁾
	2.374	0.250		HM21 R	CR 17277
	2.437	0.250		HM21 R	CR 17310
	2.441	0.250		HM21 R	CR 17340 ¹⁾
	2.441	0.250		HM21 R	CR 17341 ¹⁾²⁾
	2.441	0.469	0.254	HM18 R	CR 17359 ¹⁾
	2.502	0.250		HM21 R	CR 17392 ¹⁾
	2.561	0.250		HM21 R	CR 17415 ¹⁾
	2.562	0.500	0.286	HM18 R	CR 17406 ¹⁾
	2.623	0.250		HM21 R	CR 17461
	2.716	0.250		HM21 R	CR 17488 ¹⁾
	2.718	0.359	0.160	HM18 R	CR 17617 ¹⁾
	2.718	0.359		TL7 R	CR 17618
	2.750	0.250		HM21 R	CR 17544 ¹⁾
	2.830	0.375		HM21 R	CR 17633 ¹⁾
2.875	0.250		HM21 R	CR 17671 ¹⁾	
2.875	0.500		TL7 R	CR 17674	

1) SKF Bore Tite Coating

2) Stainless steel case

Radial shaft seals – HM and TL seals – inch dimensions

d_1 1.750 – 2.500 in.

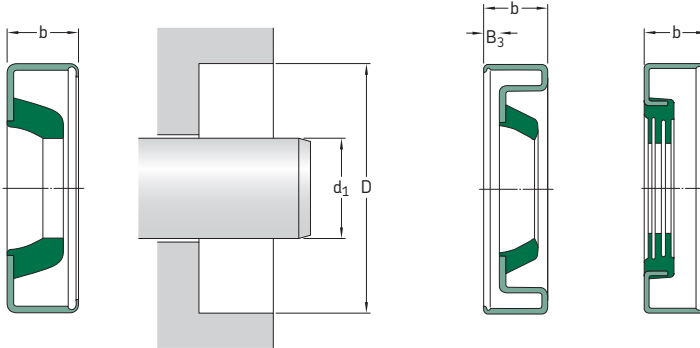

Please see pages 74 to 76 for housing bore requirements.

Dimensions Shaft	Bore	Nominal seal width b	Clearance B_3	Design and lip material	Designation
d_1	D				
in.				–	–
1.750	3.000	0.250		HM21 R	CR 17702 ¹⁾
cont.	3.149	0.290		TL6 R	CR 17724
1.781	2.126	0.250		HM14 R	CR 17802 ²⁾
1.811	2.697	0.295		HMA8 R	CR 17955
1.813	2.562	0.438	0.224	HM18 R	CR 18050 ¹⁾
	2.719	0.270		TL7 R	CR 18127
	2.965	0.250		HM1 R	CR 18258
1.875	2.502	0.250		HM21 R	CR 18558 ¹⁾
	2.623	0.250		HM21 R	CR 18591 ¹⁾
	2.750	0.250		HM21 R	CR 18659 ¹⁾
	2.780	0.250		HM21 R	CR 18704 ¹⁾
	2.875	0.250		HM21 R	CR 18750 ¹⁾
	2.997	0.250		HM14 R	CR 18808 ¹⁾
	3.000	0.250		HM21 R	CR 18823 ¹⁾
	3.150	0.250		HM21 R	CR 18889 ¹⁾
1.938	2.502	0.281		HM14 R	CR 19219 ¹⁾
	2.875	0.250		HM21 R	CR 19306 ¹⁾
	2.686	0.594		TL8 R	CR 19251 ¹⁾
1.945	2.892	0.294		TL6 R	CR 19510 ¹⁾
1.970	2.362	0.158		HM14 D	CR 532627
2.000	2.371	0.250		HM14 R	CR 19737 ¹⁾
	2.375	0.188		HM14 R	CR 19733
	2.500	0.250		HM1 R	CR 19748
	2.502	0.250		HM14 R	CR 19754 ¹⁾

¹⁾ SKF Bore Tite Coating

²⁾ Stainless steel case

Dimensions Shaft	Bore	Nominal seal width b	Clearance	Design and lip material	Designation
d ₁	D	b	B ₃		
in.				–	–
2.000 cont.	2.623	0.250	0.275	HM21 R	CR 19763 ¹⁾
	2.623	0.250		HM21 V	CR 19746 ¹⁾
	2.631	0.272		HMA94 R	CR 20016 ²⁾
	2.635	0.234		HM14 R	CR 19770 ¹⁾
	2.686	0.250		HM21 R	CR 19783 ¹⁾
	2.750	0.250		HM21 R	CR 19834 ¹⁾
	2.752	0.188		HM14 R	CR 19820 ¹⁾
	2.875	0.250		HM21 R	CR 19880 ¹⁾
	2.965	0.313		HM14 R	CR 19940 ¹⁾
	2.965	0.500		HM14 R	CR 19938 ¹⁾
	2.997	0.250		HM21 R	CR 19965
	3.000	0.250		HM21 R	CR 20006 ¹⁾
	3.061	0.250		HM21 R	CR 20044 ¹⁾
	3.148	0.250		HM14 R	CR 20078
	3.623	0.250		HM21 R	CR 20148
2.063	3.149	0.500	TL6 D	CR 20672 ¹⁾³⁾	
	3.150	0.266	TL7 R	CR 20674	
2.094	2.718	0.359	0.160	HM18 R	CR 20952 ¹⁾
	2.750	0.250		HM21 R	CR 20920 ¹⁾
2.125	2.750	0.250	HM21 R	CR 21059 ¹⁾	
	2.875	0.250	HM14 R	CR 21101 ¹⁾	
	2.891	0.250	HM14 R	CR 21121 ¹⁾	
	3.000	0.250	HM21 R	CR 21159 ¹⁾	
	3.061	0.250	HM21 R	CR 21208 ¹⁾	
3.189	0.250	HM21 R	CR 21265 ¹⁾		
2.240	3.189	0.610	HM14 R	CR 22614 ¹⁾	
2.250	2.625	0.188	HM14 R	CR 22306 ¹⁾	
	2.875	0.250	HM21 R	CR 22325	
2.297	3.000	0.250	HM21 R	CR 22368 ¹⁾	
	3.061	0.250	HM21 R	CR 22392	
	3.125	0.563	0.214	HM18 R	CR 22411
	3.251	0.250		HM21 R	CR 22468
	3.440	0.250		HM14 R	CR 22565 ¹⁾
2.297	3.148	0.359	0.185	HM18 R	CR 22870
2.313	3.000	0.250	HM14 R	CR 23035 ¹⁾	
	3.065	0.281	HM1 R	CR 23050	
	3.500	0.250	HM21 R	CR 23240 ¹⁾	
2.375	2.997	0.250	HM21 R	CR 23630 ¹⁾	
	3.000	0.250	HM21 R	CR 23640	
	3.350	0.250	HM21 R	CR 23725 ¹⁾	
	3.543	0.250	HM21 R	CR 23815 ¹⁾	
2.500	3.000	0.313	HM1 R	CR 24865	
	3.000	0.250	HM14 R	CR 24863 ¹⁾	
	3.125	0.250	HM21 R	CR 24875 ¹⁾	
	3.150	0.250	HM21 R	CR 24880 ¹⁾	
	3.251	0.250	HM21 R	CR 24904 ¹⁾	
	3.500	0.250	HM21 R	CR 25007 ¹⁾	

1) SKF Bore Tite Coating

2) Press-fit width 0.257 in.

3) Press-fit width 0.395 in.

Radial shaft seals – HM and TL seals – inch dimensions

d_1 2.625 – 9.500 in.

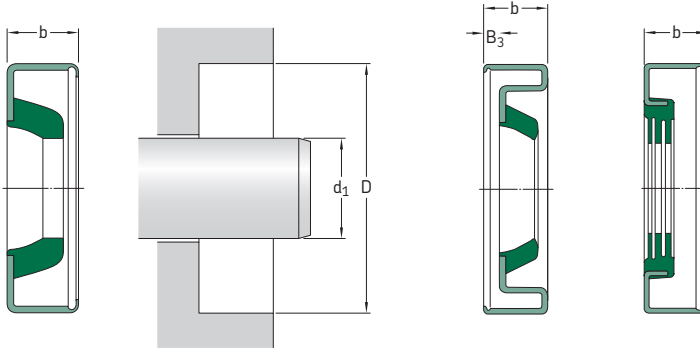

Please see pages 74 to 76 for housing bore requirements.

Dimensions Shaft	Bore	Nominal seal width b	Clearance B_3	Design and lip material	Designation
d_1	D		B_3		
in.				–	–
2.625	3.371 3.623 3.751 3.813	0.250 0.250 0.715 0.415		HM14 R HM21 R TL4 RR TL5 R	CR 26144 ¹⁾ CR 26260 ¹⁾ CR 26289 ²⁾ CR 26310 ³⁾
2.748	3.543	0.591		HM-SPL P	CR 27486
2.750	3.125 3.250 3.500 3.500 3.751	0.188 0.313 0.250 0.250 0.250		HM1 R HM1 R HM14 R HM14 V HM21 R	CR 27210 CR 27225 CR 27271 ¹⁾ CR 546751 ¹⁾ CR 27394 ¹⁾
2.875	3.751 3.876 3.876 4.003	0.250 0.188 0.250 0.250		HM21 R HM1 R HM21 R HM21 R	CR 28700 ¹⁾ CR 28725 ¹⁾ CR 28751 ¹⁾ CR 28800 ³⁾
2.953	4.724	0.320		TL1 R	CR 29590 ¹⁾
3.000	3.500 3.623 3.751 4.000 4.003 4.249	0.313 0.250 0.250 0.250 0.250 0.250		HM1 R HM14 R HM21 R HM21 V HM21 R HM21 R	CR 29840 CR 29850 CR 29863 ¹⁾ CR 539075 CR 29968 CR 30049 ¹⁾
3.125	3.751 4.125	0.250 0.250		HMA1 R HMA1 R	CR 31129 ¹⁾ CR 31192
3.250	3.750 4.249 4.501	0.250 0.250 0.250		HMA1 R HM14 R HM21 R	CR 32325 ¹⁾ CR 32412 ³⁾ CR 32510 ¹⁾

¹⁾ SKF Bore Tite Coating

²⁾ Press-fit width 0.640 in.

³⁾ Press-fit width 0.300 in.

Dimensions Shaft	Bore	Nominal seal width b	Clearance B ₃	Design and lip material	Designation
d ₁	D				
in.				–	–
3.500	4.000 4.003	0.300 0.250		HM1 R HM14 R	CR 34835 CR 34840¹⁾
	4.125 4.125	0.250 0.250		HM14 R HM14 V	CR 34848 CR 546770¹⁾
	4.450 4.501 4.751	0.531 0.250 0.250		HM12 R HM21 R HM21 R	CR 34885 CR 34967 CR 35042¹⁾
3.750	4.376 4.376	0.250 0.250		HM14 R HM14 V	CR 37320¹⁾ CR 37325¹⁾
4.000	4.501 4.501 4.876 4.999	0.250 0.250 0.250 0.250		HM14 R HM14 V HM21 R HM21 R	CR 39835¹⁾ CR 546387¹⁾ CR 39860¹⁾ CR 39961¹⁾
4.250	4.813 5.126 5.251	0.313 0.250 0.250		HM14 R HM21 R HM21 R	CR 42340 CR 42380¹⁾ CR 42470¹⁾
4.500	5.501	0.250		HM14 R	CR 45025
4.750	5.375	0.313		HM14 R	CR 47378¹⁾
4.875	5.501	0.250		HM14 R	CR 48650
5.000	6.250	0.250		HM21 R	CR 50070¹⁾
5.250	6.250	0.250		HM4 R	CR 52475
5.750	6.375 7.003	0.250 0.250		HMA1 R HMA21 R	CR 57502 CR 57571
6.000	7.500	0.250		HM4 R	CR 60075
6.374	8.749	0.421		HMA96 R	CR 181948
7.938	8.750	0.344		HM14 R	CR 79302
9.500	10.750	0.313		HM21 R	CR 95052

¹⁾ SKF Bore Tite Coating

Radial shaft seals

X seals, sealing against housing bore

SKF offers an assortment of radial shaft seals that have a press fit on the shaft and with sealing lip(s) that contact the housing bore. These seals are generally installed with the sealing lip(s) facing outward to provide optimum exclusion. Main applications are greased lubricated agriculture machinery. The selection to the right shows the most commonly used SKF designs. Contact SKF for more information on available designs.

See **matrix 1** on **pages 90** and **91** for general permissible operating conditions.

X1



X2



X4



X12



X13



X14



X15



XH15



Radial shaft seals – X seals – metric dimensions

d_1 25,40 – 82,55 mm

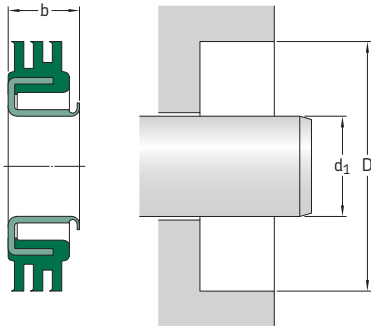

Please see pages 74 to 76 for housing bore requirements.

Dimensions Shaft	Bore	Nominal seal width b	Design and lip material	Designation
d_1	D			
mm			–	–
25,40	59,84	6,86	X15 R	CR 538266
38,10	55,55	12,70	X1 L	CR 14896
	58,06	6,86	X15 R	CR 14970
	58,06	10,67	XH15 R	CR 14971
	62,53	7,37	X13 R	CR 15174
39,70	56,82	7,37	X4 R	CR 15530
	64,29	7,24	X15 R	CR 15660
	69,85	11,13	XR	CR 15702
41,28	62,53	6,35	X15 R	CR 16286
42,88	67,31	7,37	X4 R	CR 16818
44,45	69,04	7,47	X4 R	CR 17485
	70,76	7,47	X15 R	CR 17620
46,05	61,16	7,62	X15 R	CR 18030
47,57	68,99	7,14	X13 R	CR 18630
50,57	73,66	7,37	X4 R	CR 19720
50,80	71,17	6,35	X15 D	CR 19844
	73,03	6,50	XHMR	CR 19882
53,98	82,55	6,86	X15 R	CR 21298
57,15	86,36	7,47	X15 R	CR 22563
63,40	93,27	7,95	X15 R	CR 25078
76,20	101,60	12,70	X2 L	CR 29900
	114,94	9,53	X12 R	CR 30108
80,00	101,45	15,00	X15 R	CR 31514
82,55	113,49	8,00	X4 R	CR 32437
	114,30	7,95	X15 R	CR 32441

Radial shaft seals – X seals – metric dimensions

d_1 86,36 – 158,75 mm

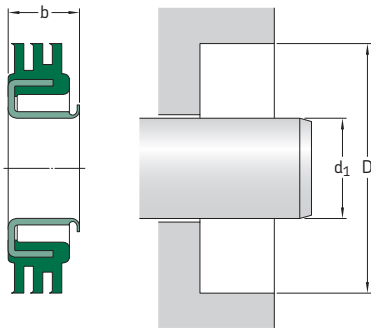

Please see **pages 74 to 76** for housing bore requirements.

Dimensions Shaft	Bore	Nominal seal width b	Design and lip material	Designation
d_1	D			
mm			–	–
86,36	114,30	7,14	X14 V	CR 34000¹⁾
92,08	114,30	7,47	X15 R	CR 36172
98,43	136,91	9,53	X12 R	CR 38590
101,60	147,65	12,70	X R	CR 40131
111,13	136,47	14,48	X1 P	CR 44269
114,30	152,78 162,79	13,97 10,54	X12 R X12 D	CR 44892 CR 45161
120,65	152,45	7,62	X15 R	CR 47455
139,70	172,21	9,65	X R	CR 55152
158,75	196,85	8,89	X R	CR 62530

¹⁾ SKF Bore Tite Coating on inside diameter

Shaft tolerance should conform to bore requirements specified on **pages 74 to 76** to maintain proper press fit.

Radial shaft seals – X seals – inch dimensions

d_1 1.000 – 3.250 in.

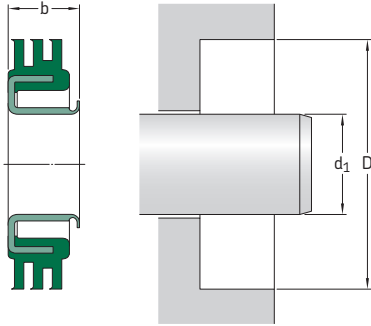

Please see pages 74 to 76 for housing bore requirements.

Dimensions Shaft	Bore	Nominal seal width b	Design and lip material	Designation
d_1	D			
in.			–	–
1.000	2.356	0.270	X15 R	CR 538266
1.500	2.187	0.500	X1 L	CR 14896
	2.286	0.270	X15 R	CR 14970
	2.286	0.420	XH15 R	CR 14971
	2.462	0.290	X13 R	CR 15174
1.563	2.237	0.290	X4 R	CR 15530
	2.531	0.285	X15 R	CR 15660
	2.684	0.438	XR	CR 15702
1.625	2.462	0.250	X15 R	CR 16286
1.688	2.650	0.290	X4 R	CR 16818
1.750	2.718	0.294	X4 R	CR 17485
	2.786	0.294	X15 R	CR 17620
1.813	2.408	0.300	X15 R	CR 18030
1.873	2.716	0.281	X13 R	CR 18630
1.991	2.900	0.290	X4 R	CR 19720
2.000	2.802	0.250	X15 D	CR 19844
	2.875	0.256	XHMR	CR 19882
2.125	3.250	0.270	X15 R	CR 21298
2.250	3.400	0.294	X15 R	CR 22563
2.496	3.672	0.313	X15 R	CR 25078
3.000	4.000	0.500	X2 L	CR 29900
	4.525	0.375	X12 R	CR 30108
3.150	3.994	0.591	X15 R	CR 31514
3.250	4.468	0.315	X4 R	CR 32437
	4.500	0.313	X15 R	CR 32441

Radial shaft seals – X seals – inch dimensions

d_1 3.400 – 6.250 in.

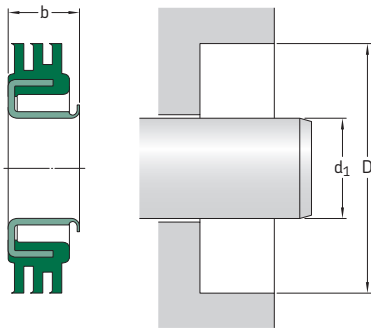

Please see **pages 74 to 76** for housing bore requirements.



















Dimensions Shaft	Bore	Nominal seal width b	Design and lip material	Designation
d_1	D			
in.			–	–
3.400	4.500	0.281	X14 V	CR 34000¹⁾
3.625	4.500	0.294	X15 R	CR 36172
3.875	5.390	0.375	X12 R	CR 38590
4.000	5.813	0.500	X R	CR 40131
4.375	5.373	0.570	X1 P	CR 44269
4.500	6.015 6.409	0.550 0.415	X12 R X12 D	CR 44892 CR 45161
4.750	6.002	0.300	X15 R	CR 47455
5.500	6.780	0.380	X R	CR 55152
6.250	7.750	0.350	X R	CR 62530

¹⁾ SKF Bore Tite Coating on inside diameter

Shaft tolerance should conform to bore requirements specified on **pages 74 to 76** to maintain proper press fit.

Radial shaft seals

Seals for heavy industrial applications, selected main designs

Standard design (preferred design)	Other basic designs		Material code	Operating temperature range				Pressure differential
				from		to		
				°C	°F	°C	°F	
 HDS7	 HDS6		R D H V (HDS6 only)	-40 -40 -40 -40	+100 +100 +150 +200	-40 -40 -40 -40	+210 +210 +300 +390	0
 HDL	 HDLA		R H V	-40 -40 -40	+100 +150 +200	-40 -40 -40	+210 +300 +390	0,1 (15)
 SBF			R V	-40 -40	+100 +200	-40 -40	+210 +390	0,1 (15)
 HDS2	 HDS1	 HDS4	R D H V	-40 -40 -40 -40	+100 +100 +150 +200	-40 -40 -40 -40	+210 +210 +300 +390	0,1 (15)
 HDSA2	 HDSA1	 HDSB2	R D H V	-40 -40 -40 -40	+100 +100 +150 +200	-40 -40 -40 -40	+210 +210 +300 +390	0,1 (15)
	 HDSB1	 HDS2						
	 HDS1							
 HDSE2	 HDSE1	 HDS2	R D H V	-40 -40 -40 -40	+100 +100 +150 +200	-40 -40 -40 -40	+210 +210 +300 +390	0,1 (15)
	 HDS1							

Shaft-to-bore misalignment (STBM) TIR	Dynamic runout (DRO) TIR	Maximum shaft surface speed	Ease of installation	Retention and exclusion ability
mm (in.)	mm (in.)	m/s (ft/min)	–	–
1,6 (0.062)	2,4 (0.093)	25 (4 900)	Excellent	Highly effective exclusion of water and solid contaminants and excellent retention of grease
2,5 (0.1)	2,4 (0.093)	24 (4 700) 25 (4 900) 35 (6 900)	Good	Excellent retention of light oils, even at high surface speeds and misalignment
1,5 (0.06)	2,4 (0.093)	25 (4 900)	Excellent	Excellent oil or grease retention
1,6 (0.062)	2,4 (0.093)	25 (4 900)	HDS2, HDS4: Excellent HDS1: Good	Excellent oil or grease retention
1,6 (0.062)	2,4 (0.093)	25 (4 900)	Excellent to good, varies with equipment design	HDSA/B: Excellent oil or grease retention and exclusion of light to moderate contaminants HDSC: Good grease retention, increased protection against contaminants
1,6 (0.062)	2,4 (0.093)	25 (4 900)	HDSD2/HDSE2: Excellent HDSD1/HDSE1: Good	Excellent oil or grease retention and exclusion of light to moderate contaminants or separation of two media Good grease retention, increased protection against contaminants

Continued →

Radial shaft seals

Seals for heavy industrial applications, selected main designs

Standard design (preferred design)	Other basic designs		Material code	Operating temperature range				Pressure differential
				from		to		
				°C	°F	°C	°F	
 HS5	 HS4		R D H V	-40 -40 -40 -40	+100 +100 +150 +200	-40 -40 -40 -40	+210 +210 +300 +390	0,07 (11)
 HS8	 HS6	 HS7	R D H V	-40 -40 -40 -40	+100 +100 +150 +200	-40 -40 -40 -40	+210 +210 +300 +390	0
 HSF5	 HSF6	 HSF7	R V	-40 -40	+100 +100	-40 -40	+210 +390	0,03 (5)
		 HSF8						
		 HSF9						
 HSF1	 HSF2	 HSF3	R V	-40 -40	+100 +200	-40 -40	+210 +390	0
	 HSF4							

Shaft-to-bore misalignment (STBM) TIR	Dynamic runout (DRO) TIR	Maximum shaft surface speed	Ease of installation	Retention and exclusion ability
mm (<i>in.</i>)	mm (<i>in.</i>)	m/s (<i>ft/min</i>)	–	–
1,6 (0.062)	2,4 (0.093)	HS4: 15 (2 950) HS5: 13 (2 560)	Good	HS4, HS5: Good oil retention
1,6 (0.062)	2,4 (0.093)	HS6: 10 (1 970) HS7: 7,5 (1 480) HS8: 10 (1 970)	HS6: Fair HS7: Excellent HS8: Good	HS6, HS8: Good to excellent oil or grease retention HS7: Good (grease retention only)
1,5 (0.06)	2,4 (0.093)	15 (2 950) depending on the operating conditions	Good to excellent	Excellent oil retention
1,5 (0.06)	2,4 (0.093)	15 (2 950) depending on the operating conditions	Fair to good depending on the available space for installation	Good to excellent oil retention

Seals for heavy industrial applications

General

Heavy industries like metal, construction, wind energy, forestry, mining and pulp and paper provide a challenging environment for radial shaft seals. Operating within a wide range of speeds, temperatures and environmental conditions, these seals need to reliably retain lubricants while preventing harsh contaminants from entering the system.

SKF seals for heavy industrial applications are available in a wide assortment of designs and materials to meet the varying demands of each challenging application. The assortment includes heavy-duty metal-cased seals, rubber outside diameter seals with metal inserts or fabric-reinforcement and all-rubber seals. To simplify seal selection, **table 18** on **page 217** can be used for general guidance. See also **matrix 2** on **pages 202 to 205**.

Metal-cased seals

General

SKF metal-cased seals are specially designed to withstand the extreme conditions encountered in heavy-duty applications. The designs include the highly engineered HDS7, the high-performance HDL seals and the commonly used HDS1 and HDS2 seals as well as the HDSA, B, C, D and E seals. These seals perform exceptionally well in the very contaminated environment of metal rolling mills, the high-speed and high-temperature environment of paper mills, as well as more universal applications like industrial gearboxes.

HDS7

The ingress of water and solid contaminants is a common cause of bearing failures. To solve this, SKF developed the HDS7 seal with enhanced exclusion capabilities (→ **fig. 33**). It was originally designed for grease lubricated bearings in rolling mill stands, where water and scale are a constant threat to bearing service life. The HDS7 is also recommended for use in large gearboxes, coal pulverizers and cement grinders. Customers have reported that the HDS7 seal is easier to install and provides longer service life than similar seal designs.



The HDS7 seal features an optimized non-spring-loaded lip profile, designed to retain grease and aggressively pump contaminants away from the lip. The lip concept of HDS7 seals also reduces radial loads, which otherwise can lead to elevated underlip temperatures and increased seal wear.

HDS7 seal can also be equipped with a PTFE auxiliary lip positioned and directed as shown in **fig. 43** on **page 210** and/or with an elastomer applied to the metal outside diameter (→ **fig. 44** on **page 210**).

The HDS7 seal is available with a nitrile sealing lip for general use, SKF Duralip for increased wear resistance in abrasive environments and SKF Duratemp that combines improved wear resistance with increased temperature capability. For certain applications, SKF Duralife can also be specified. See **page 30** for additional information about different sealing lip materials.

Spacer lugs are available as an option. See **page 215** for additional information.

HDS7 seals are available for all shaft diameters within the ranges listed in **table 19** on **page 218**. The product tables, starting on **page 220**, list a selection of available sizes. Contact your SKF sales representative for additional information regarding availability.

HDL seals

HDL seals (→ **fig. 34**) are premium metal-cased radial shaft seals for oil lubricated applications. They are specially designed for tough operating conditions including high speeds and temperatures, considerable runout and/or misalignment. The high-speed performance characteristics of HDL seals make them an excellent choice for the severe operating conditions encountered in the rolls of paper-making machines.

HDL seals feature the combination of a stainless steel garter spring and individual stainless steel finger springs around the entire circumference of the seal. This spring combination enables the seal to work effectively and provides long service life, even under severe operating conditions.

HDLA seals are designed with an elastomeric auxiliary lip for added protection against contaminants.

Both HDL and HDLA seals are available with a sealing lip made of either nitrile rubber, hydrogenated nitrile rubber or fluoro rubber (→ **page 31**). These materials enable the seals to perform well under a variety of operating speeds and temperatures. Fixed-width spacer lugs are available for both HDL and HDLA seals on a quotation basis.

A selection of available sizes is listed in the product tables starting on **page 230**. Contact your SKF sales representative for additional information regarding availability.

HDS1 and HDS2

The most commonly used metal-cased seals are the HDS1 and HDS2 seals, designed for general-purpose applications. They are equipped with a heavy-duty metal case and a stainless steel garter spring.

The HDS1 seal (→ **fig. 35**) has a spring installed in the SKF Springlock groove (→ **fig. 57** on **page 216**). For blind installations, where spring displacement may go undetected, HDS2 seals (→ **fig. 36**) have an SKF Springcover (→ **fig. 58** on **page 216**) that retains the spring in the groove. The HDS1 and HDS2 seals are available with adjustable or fixed-width spacer lugs (→ **page 215**).

The HDS1 and HDS2 seals can be designed with a PTFE auxiliary lip, positioned and directed in either of the two ways shown in **figs. 42** and **43** and/or with an elastomer applied to the metal outside diameter (→ **fig. 44** on **page 210**).

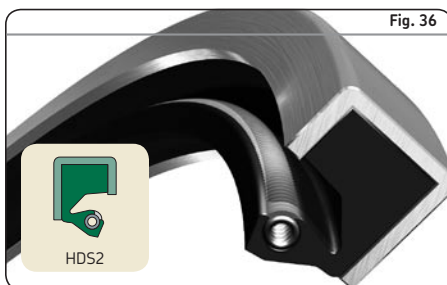
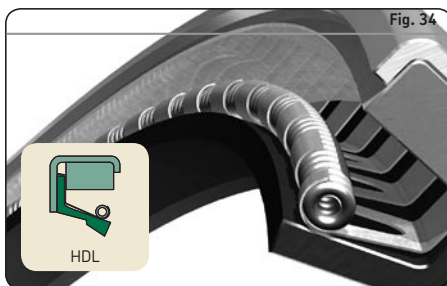

Nitrile rubber is standard for these seal designs, but both of them are also available in SKF Duralip, SKF Duratemp and SKF Duralife.

The HDS1 and HDS2 seals are available for all shaft diameters within the ranges listed in **table 19** on **page 218**. The product tables starting on **page 246** list a selection of available sizes. Contact your SKF sales representative for additional information regarding availability.

Radial shaft seals

HDSA, HDSB and HDSC seals

HDSA, HDSB and HDSC seals are designed with an elastomeric auxiliary lip in addition to the sealing lip (→ **figs. 37 to 39**). They are generally used where additional protection from contaminants is needed and where there is insufficient space for more than one seal.

The chamfer on the auxiliary lip of an HDSA seal faces the sealing lip, enabling easier shaft installation from the sealing lip direction. The chamfer of the auxiliary lip of HDSB seals faces away from the sealing lip, enabling easier shaft installation from the other direction. The disadvantage is, however, a slightly reduced exclusion ability. The auxiliary lip of HDSC seals is located in front of the sealing lip with its chamfer facing the sealing lip to provide maximum exclusion ability.

HDSA2, HDSB2 and HDSC2 seals are designed with an SKF Springcover, while HDSA1, HDSB1, HDSC1 seals are designed without an SKF Springcover (→ **fig. 58 on page 216**).

HDSA, HDSB and HDSC seals can also be designed with an elastomer applied to the metal outside diameter (→ **fig. 44 on page 210**).

HDSA, HDSB and HDSC seals are available with sealing lips made of nitrile rubber, SKF Duralip, SKF Duratemp or SKF Duralife. For shaft diameters up to 1 200 mm (47 in.), the standard auxiliary lip is made of SKF Duralip.

These seals are available for all shaft diameters within the ranges listed in **table 19 on page 218**. Also, see the product tables starting on **page 268** for a selection of available sizes. Contact your SKF sales representative for additional information regarding availability.



HDSD and HDSE seals

HDSD seals (→ **fig. 40**) are designed with two sealing lips facing opposite directions. These seals are typically used in applications where two fluids must be kept separated. When using an HDSD seal, it is very important to provide a means to lubricate the sealing lips. To do this, the cavity between the sealing lips must be filled with grease prior to installation and/or during operation via lubrication holes drilled through the metal case into the cavity.

HDSE seals (→ **fig. 41**) feature two sealing lips facing the same direction. They are typically used when a back-up seal would otherwise be needed for retention or exclusion purposes. Like HDSD seals, HDSE seals must be equipped with a means to lubricate the sealing lips so that the seal functions properly.

HDSD and HDSE seals are available with an SKF Springcover (HDSD2, HDSE2) or without an SKF Springcover (HDSD1, HDSE1) (→ **fig. 58** on **page 216**). All of them are available in nitrile rubber, SKF Duralip, SKF Duratemp or SKF Duralife.

HDSE seals can also be designed with a PTFE auxiliary lip positioned and directed in either of the two ways shown in **figs. 42** and **43** on **page 210**.

HDSD and HDSE seals are available for all shaft diameters within the ranges listed in **table 19** on **page 218**. The product tables starting on **page 274** list a selection of available sizes. Contact your SKF sales representative for additional information regarding availability.

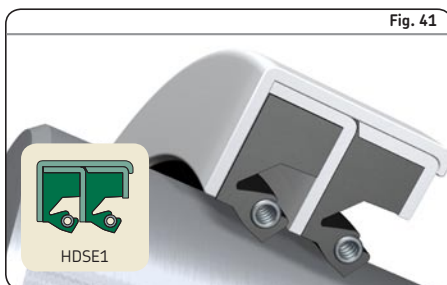

Radial shaft seals

Additional design options

HDS1, HDS2, HDS7 and HDSE seals can be designed with an auxiliary PTFE lip to further protect the bearing and sealing lip(s) from dust particles in heavily contaminated environments, for example mining and cement industries. The PTFE lip is then positioned and directed as shown in **fig. 42**.

The PTFE lip can also be positioned and directed to provide additional lubricant retention (**→ fig. 43**).

The PTFE lip is clamped between the metal case and the rubber seal body without significantly increasing the total seal width. It has very good chemical and wear resistance, can withstand dry running and contributes to improved sealing performance while only generating a minimal friction torque. The combination of a PTFE auxiliary lip and a sealing lip made of the fluoro rubber compound SKF Duralife, developed by SKF, creates a particularly effective sealing solution.

Special care must be taken to prevent damaging the PTFE lip during installation. Refer to instructions in paragraph *PTFE seals* on **page 85**.

The letters F and H in the product name indicate a PTFE auxiliary lip design including the lip's position and direction; see for example the HDSF2 (**→ fig. 42**) and HDSH2 (**→ fig. 43**).

HDS1, HDS2 and HDS7 seals (with or without an auxiliary PTFE lip) as well as the HDSA, HDSB and HDSC seals are available with an elastomer applied to the outside diameter for use in applications where bore temperatures reach maximum 100 °C (210 °F) (**→ fig. 44**). This design feature has several important advantages:

- Compensates for imperfections in the housing bore surface, improving the sealing performance by minimizing bypass leakage.
- Prevents contaminants from entering through gaps between housing bore and the seal outside diameter at, for example, out-of-round conditions.
- Minimizes the risk of damage to the housing bore during installation and removal.

This design option is indicated by the letter K in the product name; see for example the HDS2K (**→ fig. 44**).

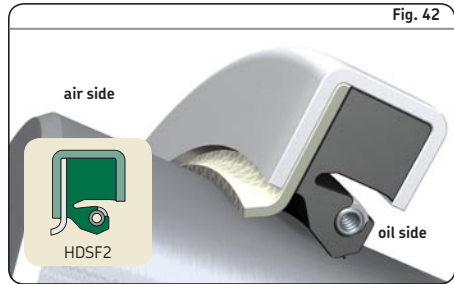

Rubber outside diameter seals

General

The assortment of SKF rubber outside diameter seals includes metal-inserted, fabric-reinforced and all-rubber designs. The fabric-reinforced and all-rubber seals are available in solid and split designs.

Rubber outside diameter seals offer a number of important operating and installation benefits and are especially suitable for split housings. The rubber prevents damage to the housing bore during installation, which otherwise can cause bypass leakage. Compared to metal-cased seals, rubber outside diameter seals can tolerate higher surface roughness in the housing bore. They also resist corrosion and do not seize in the bore, even years after installation.

As a result of lower press-in forces, rubber outside diameter seals are often easier to install than metal-cased seals. They can be installed by hand or with simple tools even when the diameters are very large. This is especially true of the fabric-reinforced and all-rubber designs. Furthermore, in the case of split seals, there is no need to remove the shaft or other machine components when replacing the seal.

SBF metal-inserted seals

SBF seals (→ **fig. 45**) are spring-loaded and designed with a flexible metal stiffening ring that enables the seal to be installed without the use of a cover plate. SBF seals can be used as an upgrade to fabric-reinforced seals in many applications that are either grease or oil lubricated. SBF seals are available in both nitrile and fluoro rubber. A selection of available sizes is listed in the product tables starting on **page 278**. Contact your SKF sales representative for additional information regarding availability.

HDS4 and HDS6 metal-inserted seals

HDS4 seals (→ **fig. 46**) feature a patented moulded-in garter spring that cannot be displaced during installation. They also provide very good oil retention while minimizing wear on the shaft. HDS4 seals are typically used in the high-speed applications found in the pulp and paper industry. HDS6 seals (→ **fig. 47**) are similar in design to HDS4 seals but do not contain a garter spring. HDS6 seals are designed for grease retention.

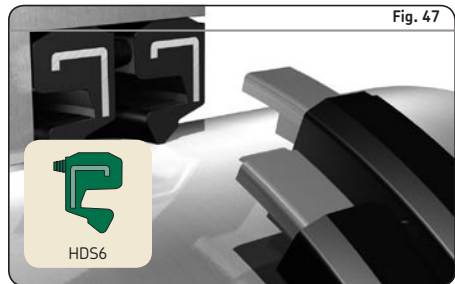
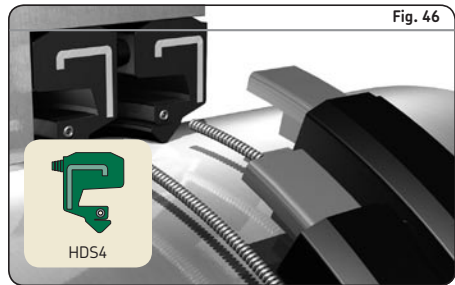
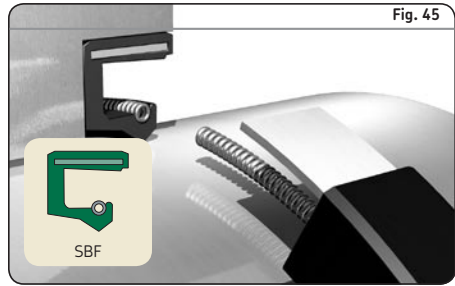

Both types are made standard of nitrile rubber. They are also available in any of the sealing lip materials used for the metal-cased HDS seals. Both HDS4 and HDS6 seals are equipped with moulded 12,7 mm (0.5 in.) spacer lugs that can be trimmed or removed if necessary.

Contact your SKF sales representative for information regarding availability.

Radial shaft seals

HSF fabric-reinforced seals

The spring-loaded HSF seal assortment consists of the HSF5, HSF6, HSF7 and HSF8 solid seals and their split versions, HSF1, HSF2, HSF3 and HSF4 seals (→ **figs. 48 to 50**). There is also a pressure profile seal, HSF9, available in the solid version only. These seals are mainly used in heavy-duty applications like gear drives, propeller shafts, cold and hot mill work rolls, pumps, paper machinery, etc.

HSF5, HSF6 and HSF7 seals have a strong, flexible, fabric-reinforced rubber back instead of a metal case. HSF5 seals have a basic single-lip design. HSF6 seals are equipped with radial lubrication grooves in the back of the seal and HSF7 seals include a circumferential lubrication groove. HSF4 and HSF8 seals are designed with an auxiliary lip for additional protection against contaminants.

Threaded spring connections are standard for all HSF seals (→ **fig. 55a on page 215**). For the split versions, a hook-and-eye connection can also be specified (→ **fig. 55b on page 215**).

All HSF seals are manufactured oversized relative to the housing bore diameter and depth to enable proper compression and stability. A cover plate is required to properly install and apply all HSF seals (→ **figs. 25 and 26 on pages 82 and 83**). The plate creates an axial preload to provide reliable static sealing performance. The plate should also avoid seal distortion during installation. HSF seals are available in nitrile rubber, hydrogenated nitrile rubber and fluoro rubber materials.

A selection of available HSF seal sizes is listed in the product tables starting on **page 280**. Contact your SKF sales representative for additional information regarding availability.



HS all-rubber seals

HS seals, available in solid and split executions, are all-rubber seals, designed without any reinforcement. They are manufactured oversized relative to the housing bore diameter and depth to enable proper compression and stability. A cover plate (→ **figs. 25 and 26 on pages 82 and 83**) is required to compress the seal axially, helping to stabilize the seal in the housing bore.

A stainless steel garter spring located in the SKF Springlock groove (→ **fig. 57 on page 216**) provides the appropriate radial load against the shaft.

For certain applications, HS seals are also available with an auxiliary lip and/or band clamp. Contact SKF for more information.

HS seals are available in nitrile rubber, SKF Duralip, SKF Duratemp or SKF Duralife for all shaft diameters within the ranges listed in **table 20 on page 219**. Also, see the product tables starting on **page 306** for a selection of available sizes. Contact your SKF sales representative for additional information regarding availability.

HS solid seals

Standard solid HS seals can accommodate shaft diameters starting at 165 mm (6.5 in.) but basically do not have an upper size limit.

HS4 seals (→ **fig. 51**) have a solid, all-rubber design and incorporate a spring-loaded sealing lip. They feature an SKF Springlock groove (→ **fig. 57 on page 216**) and are suitable for both vertical and horizontal shafts. For a proper fit in the housing bore, a cover plate is required (→ **figs. 25 and 26 on pages 82 and 83**).

HS5 seals (→ **fig. 52**) have the same basic design as HS4 seals with the addition of an SKF Springcover (→ **fig. 58 on page 216**) to hold the spring in place during installation and protect it from contaminants.

Both designs have a threaded spring connection (→ **fig. 55a on page 215**).



Fig. 51



Fig. 52

Radial shaft seals

HS split seals

In applications where shaft removal is impractical, HS all-rubber split seals are an excellent choice. They are simply placed around the shaft and pushed into the housing bore with the split at the 12 o'clock position. A cover plate must be used to compress the seal axially to stabilize it in the housing bore.

HS split seals perform best with grease or high-viscosity lubricants. However, low-viscosity lubricants are also suitable if the level of lubricant is kept below the shaft centre line, which is particularly important at considerable surface speeds. Split seals are preferably used on horizontal shafts, but can also be used on vertical shafts in grease lubricated applications.

HS6 seals (→ **fig. 53**) are designed with a spring-loaded sealing lip and an SKF Springlock (→ **fig. 57** on **page 216**). They feature a separate loose spring and a hook-and-eye spring connection for shaft diameters > 455 mm (18 in.) unless otherwise specified (→ **fig. 55b** on **page 215**). Smaller sizes of HS6 seals come with a threaded spring connection. For a proper fit in the housing bore, a cover plate is required (→ **figs. 25** and **26**, on **pages 82** and **83**).

HS7 seals (→ **fig. 54**), designed for grease lubricated applications only, have a spring-loaded sealing lip and are designed with both an SKF Springlock and SKF Springcover (→ **figs. 57** and **58** on **page 216**). All HS7 seals feature a control-wire spring connection (→ **fig. 55c** on **page 215**). The spring is completely enclosed and the connection is made by running the control wire into the centre of the spring coil across the split (butt joint). A built-in spring tension holds the sealing lip on the shaft. For a proper fit, a cover plate is required. Due to the unique design that enables easier installation, a gap may occur at the joint even after the cover plate is installed. It is necessary that the split be placed at the 12 o'clock position during installation. HS7 seals do not have the high-performance characteristics of other HS seals, but are the easiest to install.

HS8 seals (→ **fig. 54**) are designed with a spring-loaded sealing lip, SKF Springlock, SKF Springcover (→ **figs. 57** and **58** on **page 216**) and a hook-and-eye spring connection (→ **fig. 55b** on **page 215**) for shaft diameters above 455 mm (18 in.). Smaller sizes of HS8 seals come with a threaded spring connection. The spring is entirely enclosed except for a small



portion on either side of the split. HS8 seals provide the most effective sealing performance of all split HS seals and are the preferred design for retaining low-viscosity lubricants and for water exclusion. HS8 seals perform best on horizontal shafts, but can also be used on vertical shafts provided they are not flooded with lubricant. For a proper fit, a cover plate is required.

Additional design features

Spring connections

There are different ways to connect the stainless steel garter springs of HS and HSF seals. A threaded spring connection (→ **fig. 55a**) is used for all HSF seals unless otherwise specified and for the solid HS4 and HS5 seals as well as the split HS6 and HS8 seals for shaft diameters ≤ 455 mm (18 in.). A hook-and-eye spring connection (→ **fig. 55b**) is used for HS6 and HS8 seals for shaft diameters > 455 mm (18 in.). All HS7 seals feature the special control-wire connection (→ **fig. 55c**), available only for these seals.

Spacer lugs

Spacer lugs are available for all metal-cased designs to separate seals in tandem or back-to-back arrangements to provide space for sealing lip lubrication (→ **fig. 56**).

Traditional fixed-width lugs for metal-cased HDS seals are 9,5 mm (0.375 in.) in diameter and are available in widths from 3,2 mm (0.125 in.) to 12,7 mm (0.5 in.) in increments of 1,6 mm (0.063 in.). The fixed-width lug is an available option for all metal-cased seals.

All standard adjustable lugs are 9,5 mm (0.375 in.) in diameter and 9,5 mm (0.375 in.) in width. They can be adjusted to smaller widths in 1,6 mm (0.063 in.) increments by removing the steel washers. The lugs may also be removed entirely. Longer, adjustable lugs, with a width of 12,7 mm (0.5 in.), are available on request, however, it can be more difficult to reduce their width.

Certain small seal cross sections may require special small diameter lugs, 5,3 mm (0.210 in.), with a width range of 1,6 to 3,2 mm (0.063 to 0.125 in.).

The lugs are placed around the heel of the seal in four, six or eight equally spaced locations, depending on the seal outside diameter (→ **table 17**).

Fixed-width lugs are available for HDL seals on request.

Fig. 55

Spring connections

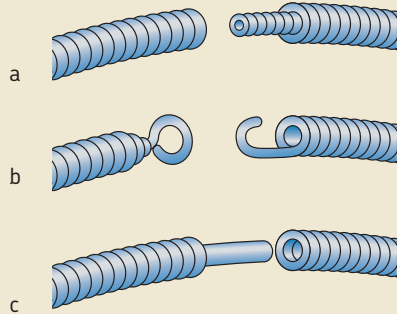

Fig. 56

Spacer lugs

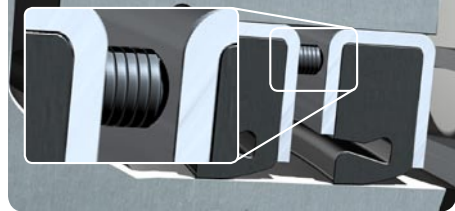

Table 17

Number of spacer lugs needed

Spacer lugs	Housing bore diameter			
	from	incl.	from	incl.
–	mm		in.	
4		762		30
6	762	1 143	30	45
8	1 143		45	

Radial shaft seals

SKF Springlock

The SKF Springlock is a sealing lip feature that surrounds 270° of the garter spring diameter (→ **fig. 57**). It helps hold the spring in position during installation and is standard on all HS seals and spring-loaded, metal-cased HDS seals.

SKF Springcover

For blind installations, where spring displacement may go undetected, the SKF Springcover can be specified. It also protects the spring from dirt, water and other contaminants. SKF Springcover is flexible and covers the exposed portion of the stainless steel garter spring without adversely affecting the spring's capability.

SKF Bore Tite Coating

SKF Bore Tite Coating is a water-based acrylic sealant available on most SKF metal-cased seals. The sealant is used as a coating on the outside diameter of the seal (→ **fig. 59**). SKF Bore Tite Coating is pliable with a thickness of 0,03 to 0,07 mm (*0.0012 to 0.0028 in.*) to help accommodate small imperfections in the housing bore surface. It can be used at temperatures up to 200 °C (390 °F) and is compatible with most oils, greases, aqueous acids and alkalis, alcohols and glycols. Note that SKF Bore Tite Coating is not compatible with aromatics, ketones or esters. Contact with these substances will, however, have little or no effect if wiped off quickly.



Table 18

Seals for heavy industrial applications, selection guide per application

Application	General machinery Industrial gearboxes	Rolling mills, metals Hot strip mills Cold rolled plate mills Industrial gearboxes	Industrial gearboxes General machinery Rolling mills, paper mills	Special machinery Crushers, shredders, bailers, etc.
Type	General purpose	Water/scale exclusion	High speed	High Dynamic Runout (DRO) or Shaft-To-Bore Misalignment (STBM)
HDS1-2, HDSD-E	3	2	1	2
HDS4, 6	3	2	3	2
HDS7	2	3	1	2
HDSA-C	3	2	1	2
HDL	2	2	3	3
HS4-8	2	1	1	2
SBF, HSF1-9	3	2	1	2

1 = Good solution 2 = Better solution 3 = Best solution

Table 19

Standard sections for metal-cased HDS seal designs

Designs with metal outside diameter	Shaft diameter		Bore diameter		Nominal seal width		Difference between bore and shaft diameter	
	from	to	from	to	from	to	from	to
	mm/in.		mm/in.		mm/in.		mm/in.	
HDS7	165,10 6.500	1 606,55 63.250	196,85 7.750	1 638,30 64.500	15,88 0.625	31,75 1.250	31,75 1.250	63,50 2.500
HDSH7	165,10 6.500	1 606,55 63.250	196,85 7.750	1 638,30 64.500	19,99 0.787	31,75 1.250	31,75 1.250	63,50 2.500
HDS1-3, HDSF1-3	165,10 6.500	1 606,55 63.250	196,85 7.750	1 638,30 64.500	15,88 0.625	31,75 1.250	31,75 1.250	76,20 3.000
HDSH1-3	165,10 6.500	1 606,55 63.250	196,85 7.750	1 638,30 64.500	19,99 0.787	31,75 1.250	31,75 1.250	76,20 3.000
HDSA1-2, HDSB1-2, HDSC1-2	165,10 6.500	1 189,74 46.840	196,85 7.750	1 219,20 48.000	21,36 0.841	38,10 1.500	31,75 1.250	76,20 3.000
HDS1-2, HDSE1-2, HDSEF1-2	165,10 6.500	1 603,50 63.130	202,18 7.960	1 638,30 64.500	30,89 1.216	50,80 2.000	37,08 1.460	76,20 3.000
HDSEH1-2	165,10 6.500	1 603,50 63.130	202,18 7.960	1 638,30 64.500	39,98 1.574	50,80 2.000	37,08 1.460	76,20 3.000

Designs with an elastomer applied to the outside diameter	Shaft diameter		Bore diameter		Nominal seal width		Difference between bore and shaft diameter	
	from	to	from	to	from	to	from	to
	mm/in.		mm/in.		mm/in.		mm/in.	
HDS7K	165,10 6.500	1 606,55 63.250	201,62 7.938	1 643,08 64.688	15,88 0.625	31,75 1.250	36,52 1.438	76,20 3.000
HDSH7K	165,10 6.500	1 606,55 63.250	201,62 7.938	1 643,08 64.688	19,99 0.787	31,75 1.250	36,52 1.438	76,20 3.000
HDS1-3K, HDSF1-3K	165,10 6.500	1 606,55 63.250	201,62 7.938	1 643,08 64.688	15,88 0.625	31,75 1.250	36,52 1.438	76,20 3.000
HDSH1-3K	165,10 6.500	1 606,55 63.250	201,62 7.938	1 643,08 64.688	19,99 0.787	31,75 1.250	36,52 1.438	76,20 3.000
HDSA1-2K, HDSB1-2K, HDSC1-2K	165,10 6.500	1 606,55 63.250	201,62 7.938	1 643,08 64.688	15,88 0.841	31,75 1.250	36,52 1.438	76,20 3.000

Not all cross sections and widths are possible with every shaft diameter. Contact SKF for availability on dimensions at the extreme limits or for sizes outside the standard range.

Size options of metal-cased HDS seals and all-rubber HS seals

All SKF metal-cased HDS seals and all-rubber HS seals are made upon order in any inch or metric size within the ranges listed in **tables 19** and **20**. Since new sizes are manufactured without additional tooling, they can be supplied without extended lead times. The product tables starting on **page 220** and **306**, respectively, list a selection of available sizes. For any size that is not listed in the product tables, contact your SKF distributor or SKF sales representative.

Table 20
Standard size options of HS seals

Shaft diameter ¹⁾		Bore diameter ²⁾		Bore depth ³⁾		Difference between bore and shaft diameter	
from	to	from	to	from	to	from	to
mm/in.		mm/in.		mm/in.		mm/in.	
165,10 6.500	4 572,00 180.000	190,50 7.500	4 597,40 181.000	12,70 0.500		25,40 1.000	
165,10 6.500	4 572,00 180.000	195,10 7.681	4 602,00 181.181	12,70 0.500	19,99 0.787	30,00 1.181	50,80 2.000
330,20 13.000	4 572,00 180.000	368,30 14.500	4 610,10 181.500	16,51 0.650	25,40 1.000	38,10 1.500	63,50 2.500

¹⁾ Tolerance h11

²⁾ Tolerance H8

³⁾ Tolerance $\pm 0,1$ mm (0.004 in.)

Not all cross sections and widths are possible with every shaft diameter. Contact SKF for availability on dimensions at the extreme limits or on sizes outside the standard range.

Radial shaft seals – HDS7 – metric dimensions

d_1 200 – 1 250 mm

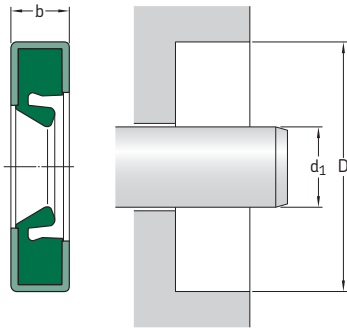

The table includes only a selection of available sizes. Contact your SKF sales representative for more information.

Please see **pages 74 to 76** for housing bore requirements.

Dimensions Shaft	Bore	Nominal seal width b	Design	Lip material	Designation
d_1	D				
mm			–	–	–
200	230	15	HDS7	R	CR 200×230×15 HDS7 R
210	240	18	HDS7	D	CR 210×240×18 HDS7 D ¹⁾
220	250	15	HDS7	R	CR 220×250×15 HDS7 R
230	260	15	HDS7	R	CR 230×260×15 HDS7 R
235	270	15	HDS7	H	CR 235×270×15 HDS7 H
	270	16	HDS7	H	CR 235×270×16 HDS7 H
260	300	16	HDS7	R	CR 260×300×16 HDS7 R
290	350	25	HDS7	R	CR 290×350×25 HDS7 R
300	340	18	HDS7	R	CR 300×340×18 HDS7 R
	340	20	HDS7	R	CR 300×340×20 HDS7 R
	344	20	HDS7	R	CR 300×344×20 HDS7 R
310	350	20	HDS7	R	CR 310×350×20 HDS7 R
320	380	28	HDS7	R	CR 320×380×28 HDS7 R
330	370	20	HDS7	R	CR 330×370×20 HDS7 R
346	375	15	HDS7	R	CR 346×375×15 HDS7 R
360	404	20	HDS7	R	CR 360×404×20 HDS7 R
364	406	17	HDS7	D	CR 364×406×17 HDS7 D
400	444	20	HDS7	R	CR 400×444×20 HDS7 R
432	463	17	HDS7	R	CR 432×463×17 HDS7 R
440	480	20	HDS7	R	CR 440×480×20 HDS7 R
450	510	25	HDS7	R	CR 450×510×25 HDS7 R

¹⁾ 12,7 mm adjustable spacer lugs (4)

Dimensions Shaft d_1	Bore D	Nominal seal width b	Design	Lip material	Designation
mm			–	–	–
461	495	20	HDS7	H	CR 461x495x20 HDS7 H
470	530 530	25 28	HDS7 HDS7	R R	CR 470x530x25 HDS7 R CR 470x530x28 HDS7 R
500	550	20	HDS7	D	CR 500x550x20 HDS7 D ²⁾
515	555	20	HDS7	R	CR 515x555x20 HDS7 R
520	570	22	HDS7	R	CR 520x570x22 HDS7 R
530	580 580	20 22	HDS7 HDS7	D R	CR 530x580x20 HDS7 D ²⁾ CR 530x580x22 HDS7 R
542	578	16	HDS7	D	CR 542x578x16 HDS7 D ¹⁾
560	604 610 610 620	20 20 22 29,34	HDS7 HDS7 HDS7 HDS7	R R R R	CR 560x604x20 HDS7 R CR 560x610x20 HDS7 R CR 560x610x22 HDS7 R CR 560x620x29 HDS7 R
590	630 640	20 20	HDS7 HDS7	D R	CR 590x630x20 HDS7 D ²⁾ CR 590x640x20 HDS7 R
610	660	25	HDS7	R	CR 610x660x25 HDS7 R
640	690	25	HDS7	R	CR 640x690x25 HDS7 R
647	700	25	HDS7	H	CR 647x700x25 HDS7 H
720	784	23	HDS7	R	CR 720x784x23 HDS7 R
760	810	25	HDS7	R	CR 760x810x25 HDS7 R
1 250	1 314	21,54	HDS7	R	CR 1250x1314x22 HDS7 R

¹⁾ 12,7 mm adjustable spacer lugs (4)

²⁾ 12,7 mm adjustable spacer lugs (6)

Radial shaft seals – HDS7 – inch dimensions

d_1 6.750 – 15.359 in.

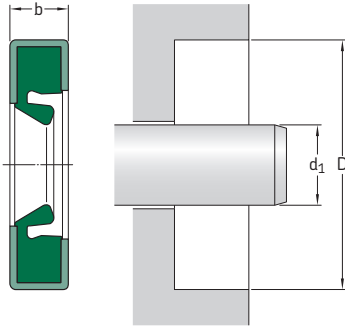

The table includes only a selection of available sizes. Contact your SKF sales representative for more information.

Please see pages 74 to 76 for housing bore requirements.

Dimensions		Nominal seal width b	Design	Lip material	Designation
Shaft	Bore				
d_1	D				
in./mm			–	–	–
6.750 171,45	8.000 203,20	0.750 19,05	HDS7	R	CR 597627
8.000 203,20	9.500 241,30	0.625 15,88	HDS7	H	CR 596567
8.375 212,73	9.750 247,65	0.750 19,05	HDS7	R	CR 596198
8.500 215,90	10.000 254,00	0.625 15,88	HDS7	R	CR 596415
9.000 228,60	10.498 266,65	0.750 19,05	HDS7	R	CR 596200
	10.500 266,70	0.625 15,88	HDS7	R	CR 597535
9.125 231,78	11.125 282,58	0.813 20,65	HDS7	R	CR 597472
9.375 238,13	11.500 292,10	0.590 14,99	HDS7	R	CR 597408
9.500 241,30	11.000 279,40	0.625 15,88	HDS7	H	CR 596566
9.750 247,65	11.000 279,40	0.625 15,88	HDS7	R	CR 596561
10.000 254,00	11.250 285,75	0.625 15,88	HDS7	R	CR 1000129
10.500 266,70	12.000 304,80	0.688 17,48	HDS7	H	CR 1050211
10.750 273,05	11.750 298,45	0.591 15,01	HDS7	R	CR 1075020
	12.750 323,85	0.625 15,88	HDS7	R	CR 596171
	12.750 323,85	0.813 20,65	HDS7	R	CR 1075559

Dimensions Shaft d ₁	Bore D	Nominal seal width b	Design	Lip material	Designation
in./mm			–	–	–
11.000 279,40	12.250 311,15	0.625 15,88	HDS7	R	CR 1100120
	13.000 330,20	0.813 20,65	HDS7	R	CR 1100519
11.250 285,75	12.750 323,85	0.625 15,88	HDS7	H	CR 1125219
11.500 292,10	13.000 330,20	0.688 17,48	HDS7	R	CR 1150229
11.750 298,45	13.250 336,55	0.688 17,48	HDS7	R	CR 1175219
12.000 304,80	13.500 342,90	0.625 15,88	HDS7	R	CR 1213210
	13.938 354,03	0.688 17,48	HDS7	R	CR 1200500
	14.000 355,60	0.813 20,65	HDS7	R	CR 1200521
12.250 311,15	13.750 349,25	0.750 19,05	HDS7	D	CR 1225259
	14.000 355,60	0.688 17,48	HDS7	R	CR 1225379
	14.250 361,95	0.750 19,05	HDS7	R	CR 1225549
	14.250 361,95	0.813 20,65	HDS7	R	CR 1225370
	14.250 361,95	1.250 31,75	HDS7	R	CR 1225589
12.500 317,50	14.000 355,60	0.688 17,48	HDS7	R	CR 1250239
12.750 323,85	14.250 361,95	0.625 15,88	HDS7	H	CR 1275219
13.000 330,20	15.000 381,00	1.000 25,40	HDS7	R	CR 1300600
13.250 336,55	15.250 387,35	0.750 19,05	HDS7	R	CR 1325569
13.500 342,90	15.500 393,70	0.813 20,65	HDS7	R	CR 1350520
13.750 349,25	15.250 387,35	0.625 15,88	HDS7	H	CR 1375719
13.875 352,43	16.000 406,40	1.000 25,40	HDS7	R	CR 1387610
14.500 368,30	16.000 406,40	0.688 17,48	HDS7	R	CR 1450220
14.750 374,65	16.500 419,10	0.688 17,48	HDS7	R	CR 1475430
15.000 381,00	17.000 431,80	0.813 20,65	HDS7	R	CR 1500510
15.250 387,35	17.250 438,15	0.625 15,88	HDS7	R	CR 1525511
15.359 390,12	17.709 449,81	0.906 23,01	HDS7	R	CR 1536691

Radial shaft seals – HDS7 – inch dimensions

d_1 15.500 – 63.250 in.

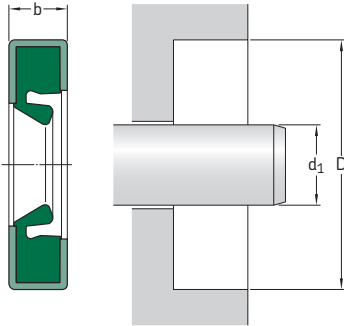

The table includes only a selection of available sizes. Contact your SKF sales representative for more information.

Please see pages 74 to 76 for housing bore requirements.

Dimensions		Nominal seal width b	Design	Lip material	Designation
Shaft	Bore				
d_1	D				
in./mm					
15.500 393,70	17.500 444,50	0.813 20,65	HDS7	R	CR 1550559
15.750 400,05	17.250 438,15	0.750 19,05	HDS7	H	CR 1575210
15.875 403,23	17.500 444,50	0.750 19,05	HDS7	H	CR 1587330
16.000 406,40	17.500 444,50	0.625 15,88	HDS7	H	CR 1600211
	18.000 457,20	0.813 20,65	HDS7	H	CR 1600519
16.250 412,75	17.750 450,85	0.688 17,48	HDS7	R	CR 1625210
16.500 419,10	18.000 457,20	0.750 19,05	HDS7	R	CR 1650280
17.000 431,80	18.500 469,90	0.625 15,88	HDS7	R	CR 1700280
	19.000 482,60	0.813 20,65	HDS7	R	CR 1700579
17.375 441,33	18.875 479,43	0.750 19,05	HDS7	R	CR 1737219
17.500 444,50	19.000 482,60	0.688 17,48	HDS7	H	CR 1750220
	19.000 482,60	0.688 17,48	HDS7	R	CR 1750221
17.875 454,03	19.875 504,83	0.750 19,05	HDS7	R	CR 1787540
19.000 482,60	20.500 520,70	0.750 19,05	HDS7	R	CR 1900211
19.250 488,95	20.750 527,05	0.625 15,88	HDS7	R	CR 596180

Dimensions Shaft d_1	Bore D	Nominal seal width b	Design	Lip material	Designation
in./mm			–	–	–
19.500 495,30	21.500 546,10	0.750 19,05	HDS7	R	CR 1950211
20.000 508,00	21.500 546,10	0.750 19,05	HDS7	R	CR 2000240
20.750 527,05	22.750 577,85	0.875 22,23	HDS7	D	CR 2075569
21.260 540,00	23.228 590,00	0.984 25,00	HDS7	R	CR 2126510
21.750 552,45	23.750 603,25	0.875 22,23	HDS7	R	CR 2175569
22.250 565,15	24.250 615,95	0.875 22,23	HDS7	H	CR 2225511
24.250 615,95	26.000 660,40	1.000 25,40	HDS7	H	CR 2425419
25.000 635,00	26.500 673,10	0.750 19,05	HDS7	R	CR 2500210
26.500 673,10	28.000 711,20	0.750 19,05	HDS7	R	CR 2650240
27.000 685,80	29.000 736,60	0.875 22,23	HDS7	R	CR 2700519
27.500 698,50	29.500 749,30	0.875 22,23	HDS7	R	CR 2750510
27.875 708,03	29.815 757,30	0.875 22,23	HDS7	R	CR 2788600
28.000 711,20	29.500 749,30	0.750 19,05	HDS7	R	CR 2800240
	30.000 762,00	0.875 22,23	HDS7	R	CR 2800590
	30.500 774,70	1.000 25,40	HDS7	H	CR 2800650
28.500 723,90	30.500 774,70	0.875 22,23	HDS7	H	CR 2850211
29.000 736,60	31.000 787,40	0.875 22,23	HDS7	R	CR 2900579
30.500 774,70	32.500 825,50	0.875 22,23	HDS7	H	CR 3050511
30.615 777,62	33.268 845,01	1.094 27,79	HDS7	R	CR 3061721
31.496 800,00	33.465 850,01	0.984 24,99	HDS7	R	CR 3149470
40.500 1 028,70	41.750 1 060,45	0.750 19,05	HDS7	H	CR 4050061
47.000 1 193,80	49.000 1 244,60	0.875 22,23	HDS7	H	CR 4700511
57.875 1 470,03	60.000 1 524,00	0.938 23,83	HDS7	R	CR 5787611
63.250 1 606,55	64.500 1 638,30	1.188 31,75	HDS7	R	CR 6325100

Radial shaft seals – HDS7K – metric dimensions

d₁ 200 – 810 mm

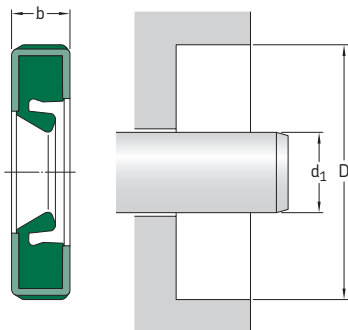

The table includes only a selection of available sizes. Contact your SKF sales representative for more information.

Please see **pages 74 to 76** for housing bore requirements.

Dimensions Shaft	Bore	Nominal seal width	Design	Lip material	Designation
d ₁	D	b			
mm			–	–	–
200	230	15	HDS7K	R	CR 200×230×15 HDS7K R
230	260	15	HDS7K	R	CR 230×260×15 HDS7K R
280	310	15	HDS7K	R	CR 280×310×15 HDS7K R
	320	18	HDS7K	R	CR 280×320×18 HDS7K R ¹⁾
	320	20	HDS7K	R	CR 280×320×20 HDS7K R
310	350	20	HDS7K	R	CR 310×350×20 HDS7K R
320	360	25	HDS7K	R	CR 320×360×25 HDS7K R ²⁾
360	404	20	HDS7K	R	CR 360×404×20 HDS7K R
400	450	18	HDS7K	R	CR 400×450×18 HDS7K R
	450	22	HDS7K	R	CR 400×450×22 HDS7K R
446	496	22	HDS7K	R	CR 446×496×22 HDS7K R
450	500	18	HDS7K	R	CR 450×500×18 HDS7K R
	500	22	HDS7K	R	CR 450×500×22 HDS7K R
485	535	22	HDS7K	R	CR 485×535×22 HDS7K R
520	570	18	HDS7K	H	CR 520×570×18 HDS7K H
	570	18	HDS7K	H	CR 520×570×18 HDS7K H ³⁾
530	580	22	HDS7K	R	CR 530×580×22 HDS7K R
	580	20	HDS7K	R	CR 530×580×20 HDS7K R ¹⁾
540	590	18	HDS7K	R	CR 540×590×18 HDS7K R
560	610	20	HDS7K	R	CR 560×610×20 HDS7K R ¹⁾

¹⁾ 3,18 mm lugs (4)

²⁾ 4,77 mm lugs (4)

³⁾ 7,95 mm lugs (6)

Dimensions			Design	Lip material	Designation
Shaft	Bore	Nominal seal width			
d_1	D	b			
mm			–	–	–
570	610	18	HDS7K	H	CR 570×610×18 HDS7K H
	610	18	HDS7K	H	CR 570×610×18 HDS7K H ⁴⁾
	620	22	HDS7K	R	CR 570×620×22 HDS7K R
760	824	25	HDS7K	R	CR 760×824×25 HDS7K R
810	874	25	HDS7K	R	CR 810×874×25 HDS7K R

2.10

⁴⁾ 1,60 mm lugs (6)

Radial shaft seals – HDS7K – inch dimensions

d_1 15.750 – 16.500 in.

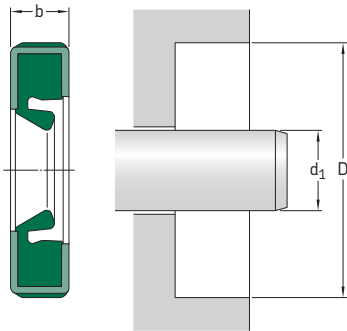

The table includes only a selection of available sizes. Contact your SKF sales representative for more information.

Please see pages 74 to 76 for housing bore requirements.

Dimensions		Nominal seal width b	Design	Lip material	Designation
Shaft	Bore				
d_1	D				
in./mm			–	–	–
15.750 400,05	17.250 438,15	0.688 17,48	HDS7K	R	CR 1575241
16.000 406,40	18.000 457,20	0.807 20,50	HDS7K	R	CR 1600562
16.500 419,10	18.000 457,20	0.750 19,05	HDS7K	R	CR 1650248

Radial shaft seals – HDL – metric dimensions

d_1 200 – 1 380 mm

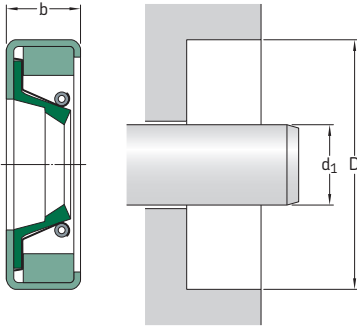

The table includes only a selection of available sizes. Contact your SKF sales representative for more information.

Please see **pages 74 to 76** for housing bore requirements.

Dimensions		Nominal seal width b	Designations	
Shaft d_1	Bore D		Lip material R	V
mm			–	
200	240	20	CR 200×240×20 HDL R	CR 200×240×20 HDL V
220	250	18	CR 220×250×18 HDL R	CR 220×250×18 HDL V
232	269,87	17,45	CR 232×270×17 HDL R	CR 232×270×17 HDL V
240	270	15	CR 240×270×15 HDL R	CR 240×270×15 HDL V
	280	20	CR 240×280×20 HDL R	CR 240×280×20 HDL V
270	308	17,45	CR 270×308×17 HDL R	CR 270×308×17 HDL V
280	320	19,98	CR 280×320×20 HDL R	CR 280×320×20 HDL V
	340	20,62	CR 280×340×21 HDL R	CR 280×340×21 HDL V
330	370	18	CR 330×370×18 HDL R	CR 330×370×18 HDL V
360	404	17,45	CR 360×404×17 HDL R	CR 360×404×17 HDL V
390	430	16	CR 390×430×16 HDL R	CR 390×430×16 HDL V
400	440	20	CR 400×440×20 HDL R	CR 400×440×20 HDL V
	450	17,45	CR 400×450×17 HDL R	CR 400×450×17 HDL V
420	460	17,45	CR 420×460×17 HDL R	CR 420×460×17 HDL V
	460	20	CR 420×460×20 HDL R	CR 420×460×20 HDL V
	470	17,45	CR 420×470×17 HDL R	CR 420×470×17 HDL V
440	480	20	CR 440×480×20 HDL R	CR 440×480×20 HDL V
470	520	22	CR 470×520×22 HDL R	CR 470×520×22 HDL V
480	520	20	CR 480×520×20 HDL R	CR 480×520×20 HDL V
485	535	19	CR 485×535×19 HDL R	CR 485×535×19 HDL V
500	550	19	CR 500×550×19 HDL R	CR 500×550×19 HDL V
508	560	25	CR 508×560×25 HDL R	CR 508×560×25 HDL V
513	543	16	CR 513×543×16 HDL R	CR 513×543×16 HDL V

Dimensions Shaft	Bore	Nominal seal width b	Designation Lip material	
d ₁	D		R	V
mm			–	
520	560 570	18 22	CR 520×560×18 HDL R CR 520×570×22 HDL R	CR 520×560×18 HDL V CR 520×570×22 HDL V
530	580	20,62	CR 530×580×21 HDL R	CR 530×580×21 HDL V
540	590	24,98	CR 540×590×25 HDL R	CR 540×590×25 HDL V
560	610	20	CR 560×610×20 HDL R	CR 560×610×20 HDL V
565	601	20	CR 565×601×20 HDL R	CR 565×601×20 HDL V
600	640	20	CR 600×640×20 HDL R	CR 600×640×20 HDL V
630	670	20	CR 630×670×20 HDL R	CR 630×670×20 HDL V
640	680	20	CR 640×680×20 HDL R	CR 640×680×20 HDL V
650	714	25	CR 650×714×25 HDL R	CR 650×714×25 HDL V
668	706	25,40	CR 668×706×25 HDL R	CR 668×706×25 HDL V
750	814	25	CR 750×814×25 HDL R	CR 750×814×25 HDL V
760	804	18	CR 760×804×18 HDL R	CR 760×804×18 HDL V
780	844	25	CR 780×844×25 HDL R	CR 780×844×25 HDL V
790	854	25	CR 790×854×25 HDL R	CR 790×854×25 HDL V
837	889	22,22	CR 837×889×22 HDL R	CR 837×889×22 HDL V
838,10	881	20	CR 838×881×20 HDL R	CR 838×881×20 HDL V
840	904	25	CR 840×904×25 HDL R	CR 840×904×25 HDL V
920	958,01	19,05	CR 920×958×19 HDL R	CR 920×958×19 HDL V
930	980	22,22	CR 930×980×22 HDL R	CR 930×980×22 HDL V
990	1 040	25	CR 990×1040×25 HDL R	CR 990×1040×25 HDL V
1000	1 050	22,22	CR 1000×1050×22 HDL R	CR 1000×1050×22 HDL V
1 055	1 100	25	CR 1055×1100×25 HDL R	CR 1055×1100×25 HDL V
1 105	1 160	22	CR 1105×1160×22 HDL R	CR 1105×1160×22 HDL V
1 350	1 414 1 415	22 25	CR 1350×1414×22 HDL R CR 1350×1415×25 HDL R	CR 1350×1414×22 HDL V CR 1350×1415×25 HDL V
1 380	1 440	25	CR 1380×1440×25 HDL R	CR 1380×1440×25 HDL V

Radial shaft seals – HDL – inch dimensions

d_1 6.125 – 11.750 in.

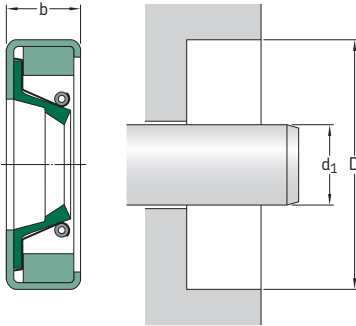

The table includes only a selection of available sizes. Contact your SKF sales representative for more information.

Please see pages 74 to 76 for housing bore requirements.

Dimensions		Nominal seal width b	Designations	
Shaft d_1	Bore D		Lip material R	V
in./mm				
6.125 155,58	7.625 193,68	0.687 17,45	CR HDL 1299 R	CR HDL 1299 V
7.125 180,98	8.250 209,55	0.750 19,05	CR HDL 3011 R	CR HDL 3011 V
7.875 200,03	9.375 238,13	0.687 17,45	CR HDL 9176 R	CR HDL 9176 V
8.000 203,20	9.500 241,30	0.687 17,45	CR HDL 3921 R	CR HDL 3921 V
8.125 206,38	10.125 257,18	0.687 17,45	CR HDL 9712 R	CR HDL 9712 V
8.250 209,55	10.250 260,35	0.813 20,65	CR HDL 4499 R	CR HDL 4499 V
8.375 212,73	9.875 250,83	0.687 17,45	CR HDL 3933 R	CR HDL 3933 V
	10.375 263,53	0.813 20,65	CR HDL 4500 R	CR HDL 4500 V
8.500 215,90	9.750 247,65	0.562 14,28	CR HDL 1705 R	CR HDL 1705 V
	10.000 254,00	0.687 17,45	CR HDL 8453 R	CR HDL 8453 V
8.625 219,08	10.125 257,18	0.687 17,45	CR HDL 3939 R	CR HDL 3939 V
	10.750 273,05	0.813 20,65	CR HDL 7718 R	CR HDL 7718 V
8.750 222,25	10.250 260,35	0.687 17,45	CR HDL 3946 R	CR HDL 3946 V
	10.750 273,05	0.813 20,65	CR HDL 3952 R	CR HDL 3952 V
8.875 225,43	10.875 276,23	0.813 20,65	CR HDL 3953 R	CR HDL 3953 V

Dimensions			Designations	
Shaft	Bore	Nominal seal width	Lip material	
d_1	D	b	R	V
in./mm			–	
9.000 228,60	10.500 266,70	0.688 17,45	CR HDL 3954 R	CR HDL 3954 V
9.125 231,78	10.625 269,88	0.687 17,45	CR HDL 3957 R	CR HDL 3957 V
9.250 234,95	10.750 273,05	0.687 17,45	CR HDL 3963 R	CR HDL 3963 V
9.375 238,13	11.375 288,93	0.813 20,65	CR HDL 4610 R	CR HDL 4610 V
9.500 241,30	10.750 273,05	0.562 14,28	CR HDL 3145 R	CR HDL 3145 V
	11.500 292,10	0.813 20,65	CR HDL 3984 R	CR HDL 3984 V
9.750 247,65	11.125 282,58	0.562 14,28	CR HDL 1692 R	CR HDL 1692 V
	11.750 298,45	0.687 17,45	CR HDL 9425 R	CR HDL 9425 V
10.000 254,00	11.500 292,10	0.687 17,45	CR HDL 3992 R	CR HDL 3992 V
	12.000 304,80	0.813 20,65	CR HDL 3997 R	CR HDL 3997 V
10.125 257,18	11.625 295,28	0.687 17,45	CR HDL 3999 R	CR HDL 3999 V
10.250 260,35	11.750 298,45	0.687 17,45	CR HDL 4004 R	CR HDL 4004 V
10.500 266,70	12.000 304,80	0.687 17,45	CR HDL 4011 R	CR HDL 4011 V
10.750 273,05	12.250 311,15	0.687 17,45	CR HDL 4023 R	CR HDL 4023 V
	12.750 323,85	0.625 15,88	CR HDL 3014 R	CR HDL 3014 V
10.875 276,23	12.375 314,33	0.687 17,45	CR HDL 4027 R	CR HDL 4027 V
11.000 279,40	12.250 311,15	0.562 14,28	CR HDL 3135 R	CR HDL 3135 V
	13.000 330,20	0.688 17,45	CR HDL 6034 R	CR HDL 6034 V
11.125 282,58	13.000 330,20	0.687 17,45	CR HDL 3699 R	CR HDL 3699 V
11.250 285,75	12.750 323,85	0.687 17,45	CR HDL 4527 R	CR HDL 4527 V
	13.250 336,55	0.813 20,65	CR HDL 4047 R	CR HDL 4047 V
11.375 288,93	13.375 339,73	0.813 20,65	CR HDL 4052 R	CR HDL 4052 V
11.500 292,10	13.000 330,20	0.687 17,45	CR HDL 4057 R	CR HDL 4057 V
11.750 298,45	13.250 336,55	0.687 17,45	CR HDL 4064 R	CR HDL 4064 V

Radial shaft seals – HDL – inch dimensions

d_1 12.000 – 15.125 in.

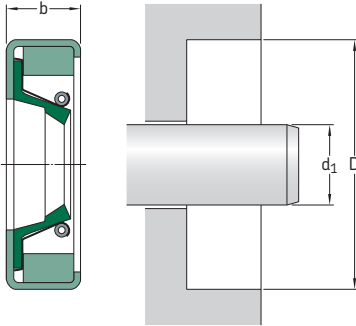

The table includes only a selection of available sizes. Contact your SKF sales representative for more information.

Please see pages 74 to 76 for housing bore requirements.

Dimensions		Nominal seal width b	Designations	
Shaft	Bore		Lip material	
d_1	D		R	V
in./mm			–	
12.000 304,80	13.500	0.687	CR HDL 4612 R	CR HDL 4612 V
	342,90	17,45		
	13.750	0.687	CR HDL 3701 R	CR HDL 3701 V
	349,25	17,45		
12.125 307,98	13.875	0.687	CR HDL 4053 R	CR HDL 4053 V
	352,43	17,45		
12.250 311,15	13.750	0.687	CR HDL 4613 R	CR HDL 4613 V
	349,25	17,45		
	14.000	0.687	CR HDL 4055 R	CR HDL 4055 V
	355,60	17,45		
12.375 314,33	13.875	0.687	CR HDL 4076 R	CR HDL 4076 V
	352,43	17,45		
	14.375	0.687	CR HDL 4097 R	CR HDL 4097 V
	365,13	17,45		
12.500 317,50	14.000	0.687	CR HDL 4079 R	CR HDL 4079 V
	355,60	17,45		
12.625 320,68	14.125	0.687	CR HDL 4081 R	CR HDL 4081 V
	358,78	17,45		
12.687 322,24	14.750	0.813	CR HDL 9766 R	CR HDL 9766 V
	374,65	20,65		
12.750 323,85	14.250	0.687	CR HDL 4089 R	CR HDL 4089 V
	361,95	17,45		
	15.000	0.813	CR HDL 4092 R	CR HDL 4092 V
	381,00	20,65		
12.875 327,03	15.000	0.813	CR HDL 5404 R	CR HDL 5404 V
	381,00	20,65		
13.000 330,20	14.500	0.687	CR HDL 4093 R	CR HDL 4093 V
	368,30	17,45		

Dimensions			Designations	
Shaft	Bore	Nominal seal width	Lip material	
d_1	D	b	R	V
in./mm			–	
13.250	14.750	0.687	CR HDL 4101 R	CR HDL 4101 V
336,55	374,65	17,45		
	15.000	0.687	CR HDL 7169 R	CR HDL 7169 V
	381,00	17,45		
13.500	15.000	0.687	CR HDL 4121 R	CR HDL 4121 V
342,90	381,00	17,45		
	15.750	0.813	CR HDL 4123 R	CR HDL 4123 V
	400,05	20,65		
13.625	15.500	0.687	CR HDL 4120 R	CR HDL 4120 V
346,08	393,70	17,45		
13.750	15.250	0.687	CR HDL 4529 R	CR HDL 4529 V
349,25	387,35	17,45		
13.813	16.000	0.813	CR HDL 4108 R	CR HDL 4108 V
350,85	406,40	20,65		
13.875	16.000	0.813	CR HDL 4110 R	CR HDL 4110 V
352,43	406,40	20,65		
13.937	15.437	0.687	CR HDL 4130 R	CR HDL 4130 V
354,00	392,10	17,45		
	15.500	0.687	CR HDL 4111 R	CR HDL 4111 V
	393,70	17,45		
14.000	15.500	0.687	CR HDL 4131 R	CR HDL 4131 V
355,60	393,70	17,45		
	15.750	0.750	CR HDL 4134 R	CR HDL 4134 V
	400,05	19,05		
14.187	16.732	0.813	CR HDL 9280 R	CR HDL 9280 V
360,34	424,99	20,65		
14.250	15.750	0.687	CR HDL 4118 R	CR HDL 4118 V
361,95	400,05	17,45		
14.375	16.000	0.687	CR HDL 5481 R	CR HDL 5481 V
365,13	406,40	17,45		
14.500	16.000	0.687	CR HDL 4142 R	CR HDL 4142 V
368,30	406,40	17,45		
14.625	16.250	0.687	CR HDL 3856 R	CR HDL 3856 V
371,48	412,75	17,45		
14.750	16.250	0.687	CR HDL 4147 R	CR HDL 4147 V
374,65	412,75	17,45		
	16.500	0.687	CR HDL 5990 R	CR HDL 5990 V
	419,10	17,45		
14.875	16.500	0.687	CR HDL 3858 R	CR HDL 3858 V
377,83	419,10	17,45		
	16.875	0.937	CR HDL 2622 R	CR HDL 2622 V
	428,63	23,80		
14.906	17.000	0.813	CR HDL 3861 R	CR HDL 3861 V
378,61	431,80	20,65		
15.000	16.500	0.687	CR HDL 4151 R	CR HDL 4151 V
381,00	419,10	17,45		
15.125	16.750	0.687	CR HDL 4165 R	CR HDL 4165 V
384,18	425,45	17,45		

Radial shaft seals – HDL – inch dimensions

d_1 15.250 – 19.250 in.

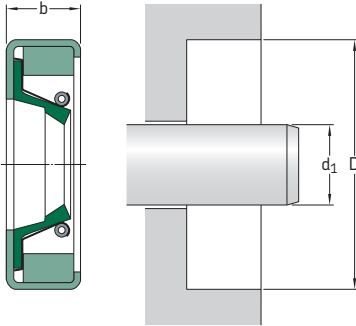

The table includes only a selection of available sizes. Contact your SKF sales representative for more information.

Please see pages 74 to 76 for housing bore requirements.

Dimensions		Nominal seal width b	Designations	
Shaft d_1	Bore D		Lip material R	V
in./mm			–	
15.250 387,35	16.750	0.687	CR HDL 4615 R	CR HDL 4615 V
	425,45	17,45		
	17.250	0.875	CR HDL 3030 R	CR HDL 3030 V
	438,15	22,23		
15.313 388,95	16.875	0.687	CR HDL 4158 R	CR HDL 4158 V
	428,63	17,45		
15.359 390,11	17.717	0.687	CR HDL 4166 R	CR HDL 4166 V
	450,01	17,45		
15.375 390,53	17.250	0.687	CR HDL 4167 R	CR HDL 4167 V
	438,15	17,45		
15.500 393,70	17.496	0.813	CR HDL 4163 R	CR HDL 4163 V
	444,40	20,65		
15.750 400,05	17.165	0.687	CR HDL 9986 R	CR HDL 9986 V
	436,00	17,45		
	17.312	0.687	CR HDL 9271 R	CR HDL 9271 V
	439,72	17,45		
15.875 403,23	17.875	0.813	CR HDL 4176 R	CR HDL 4176 V
	454,03	20,65		
16.000 406,40	17.500	0.687	CR HDL 4177 R	CR HDL 4177 V
	444,50	17,45		
	18.000	0.813	CR HDL 4180 R	CR HDL 4180 V
	457,20	20,65		
16.250 412,75	17.750	0.687	CR HDL 4181 R	CR HDL 4181 V
	450,85	17,45		
	18.000	0.750	CR HDL 4184 R	CR HDL 4184 V
	457,20	19,05		
16.375 415,93	17.875	0.687	CR HDL 4179 R	CR HDL 4179 V
	454,03	17,45		
16.500 419,10	18.000	0.687	CR HDL 9863 R	CR HDL 9863 V
	457,20	17,45		
	18.500	0.813	CR HDL 4186 R	CR HDL 4186 V
	469,90	20,65		

Dimensions Shaft d ₁	Bore D	Nominal seal width b	Designations	
			Lip material R	V
in./mm			-	
16.535 419,98	18,504 470,00	0.875 22,23	CR HDL 1929 R	CR HDL 1929 V
16.750 425,45	18,250 463,55	0.687 17,45	CR HDL 3744 R	CR HDL 3744 V
	19,000 482,60	0.813 20,65	CR HDL 3748 R	CR HDL 3748 V
16.937 430,19	19,291 489,99	0.813 20,65	CR HDL 9695 R	CR HDL 9695 V
17.000 431,80	18,500 469,90	0.687 17,45	CR HDL 4188 R	CR HDL 4188 V
	19,250 488,95	0.813 20,65	CR HDL 4191 R	CR HDL 4191 V
17.250 438,15	18,750 476,25	0.687 17,45	CR HDL 3751 R	CR HDL 3751 V
17.500 444,50	19,000 482,60	0.687 17,45	CR HDL 4194 R	CR HDL 4194 V
	19,250 488,95	1.000 25,40	CR HDL 3005 R	CR HDL 3005 V
17.625 447,68	19,250 488,95	0.687 17,45	CR HDL 4199 R	CR HDL 4199 V
	19,625 498,48	0.687 17,45	CR HDL 6850 R	CR HDL 6850 V
17.750 450,85	19,750 501,65	0.813 20,65	CR HDL 4200 R	CR HDL 4200 V
	20,078 509,98	0.875 22,23	CR HDL 9084 R	CR HDL 9084 V
17.875 454,03	19,875 504,83	0.813 20,65	CR HDL 4204 R	CR HDL 4204 V
18.000 457,20	19,500 495,30	0.687 17,45	CR HDL 4206 R	CR HDL 4206 V
	19,750 501,65	0.687 17,45	CR HDL 5728 R	CR HDL 5728 V
18.120 460,25	20,500 520,70	0.875 22,23	CR HDL 3754 R	CR HDL 3754 V
18.125 460,38	20,500 520,70	0.875 22,23	CR HDL 3756 R	CR HDL 3756 V
18.250 463,55	19,750 501,65	0.687 17,45	CR HDL 3757 R	CR HDL 3757 V
18.375 466,73	19,875 504,83	0.687 17,45	CR HDL 4213 R	CR HDL 4213 V
	19,937 506,39	0.687 17,45	CR HDL 7103 R	CR HDL 7103 V
18.500 469,90	20,000 508,00	0.687 17,45	CR HDL 3768 R	CR HDL 3768 V
	20,250 514,35	0.687 17,45	CR HDL 3772 R	CR HDL 3772 V
19.000 482,60	20,500 520,70	0.750 19,05	CR HDL 4218 R	CR HDL 4218 V
	21,000 533,40	0.875 22,23	CR HDL 4219 R	CR HDL 4219 V
19.250 488,95	20,750 527,05	0.750 19,05	CR HDL 4617 R	CR HDL 4617 V

Radial shaft seals – HDL – inch dimensions

d_1 19.375 – 23.375 in.

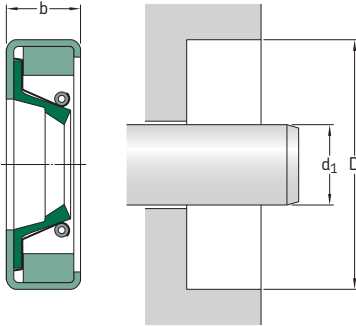

The table includes only a selection of available sizes. Contact your SKF sales representative for more information.

Please see pages 74 to 76 for housing bore requirements.

Dimensions		Nominal seal width b	Designations	
Shaft	Bore		Lip material	
d_1	D		R	V
in./mm			–	
19.375 492,13	21.000 533,40	0.750 19,05	CR HDL 3778 R	CR HDL 3778 V
19.500 495,30	21.000 533,40	0.750 19,05	CR HDL 3779 R	CR HDL 3779 V
	21.500 546,10	0.875 22,23	CR HDL 4221 R	CR HDL 4221 V
19.750 501,65	21.750 552,45	0.875 22,23	CR HDL 4228 R	CR HDL 4228 V
	22.125 561,98	0.875 22,23	CR HDL 7400 R	CR HDL 7400 V
19.875 504,83	22.000 558,80	0.875 22,23	CR HDL 3788 R	CR HDL 3788 V
19.937 506,40	21.687 550,84	0.625 15,88	CR HDL 4233 R	CR HDL 4233 V
	21.500 546,10	0.750 19,05	CR HDL 3789 R	CR HDL 3789 V
20.000 508,00	21.500 546,10	0.750 19,05	CR HDL 4235 R	CR HDL 4235 V
20.143 511,63	22.250 565,15	0.875 22,23	CR HDL 3792 R	CR HDL 3792 V
20.250 514,35	21.750 552,45	0.750 19,05	CR HDL 4239 R	CR HDL 4239 V
	22.250 565,15	0.875 22,23	CR HDL 4240 R	CR HDL 4240 V
20.438 519,13	22.500 571,50	0.813 20,65	CR HDL 4242 R	CR HDL 4242 V
20.500 520,70	22.000 558,80	0.750 19,05	CR HDL 4619 R	CR HDL 4619 V
20.625 523,88	22.625 574,68	0.813 20,65	CR HDL 9893 R	CR HDL 9893 V

Dimensions			Designations	
Shaft	Bore	Nominal seal width	Lip material	
d_1	D	b	R	V
in./mm			-	
20.750 527,05	22.750 577,85	0.875 22,23	CR HDL 4248 R	CR HDL 4248 V
20.875 530,23	22.875 581,03	0.875 22,23	CR HDL 4250 R	CR HDL 4250 V
21.000 533,40	22.500 571,50	0.750 19,05	CR HDL 5259 R	CR HDL 5259 V
	23.000 584,20	0.813 20,65	CR HDL 6535 R	CR HDL 6535 V
21.250 539,75	23.000 584,20	0.750 19,05	CR HDL 4255 R	CR HDL 4255 V
21.437 544,49	23.187 588,94	0.750 19,05	CR HDL 4256 R	CR HDL 4256 V
21.500 546,10	23.250 590,55	0.750 19,05	CR HDL 4257 R	CR HDL 4257 V
	23.500 596,90	0.875 22,23	CR HDL 4259 R	CR HDL 4259 V
21.625 549,28	23.375 593,73	0.750 19,05	CR HDL 4261 R	CR HDL 4261 V
21.750 552,45	23.250 590,55	0.750 19,05	CR HDL 4621 R	CR HDL 4621 V
	24.750 628,65	0.875 22,23	CR HDL 4262 R	CR HDL 4262 V
22.000 558,80	23.500 596,90	0.750 19,05	CR HDL 4269 R	CR HDL 4269 V
	24.250 615,95	0.813 20,65	CR HDL 9082 R	CR HDL 9082 V
22.250 565,15	24.250 615,95	0.875 22,23	CR HDL 3764 R	CR HDL 3764 V
22.375 568,33	24.250 615,95	0.750 19,05	CR HDL 4268 R	CR HDL 4268 V
	24.375 619,13	0.875 22,23	CR HDL 2576 R	CR HDL 2576 V
22.437 569,89	24.000 609,60	0.750 19,05	CR HDL 4275 R	CR HDL 4275 V
22.500 571,50	24.000 609,60	0.750 19,05	CR HDL 4271 R	CR HDL 4271 V
	24.500 622,30	0.875 22,23	CR HDL 4279 R	CR HDL 4279 V
	24.750 628,65	0.875 22,23	CR HDL 4273 R	CR HDL 4273 V
22.750 577,85	24.750 628,65	0.875 22,23	CR HDL 4281 R	CR HDL 4281 V
23.000 584,20	24.500 622,30	0.750 19,05	CR HDL 4283 R	CR HDL 4283 V
	24.750 628,65	0.750 19,05	CR HDL 5421 R	CR HDL 5421 V
23.250 590,55	25.000 635,00	0.750 19,05	CR HDL 4286 R	CR HDL 4286 V
	25.250 641,35	0.750 19,05	CR HDL 9371 R	CR HDL 9371 V
23.375 593,73	25.375 644,53	0.875 22,23	CR HDL 4287 R	CR HDL 4287 V

Radial shaft seals – HDL – inch dimensions

d_1 23.500 – 29.500 in.

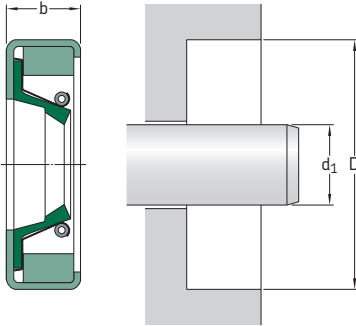

The table includes only a selection of available sizes. Contact your SKF sales representative for more information.

Please see pages 74 to 76 for housing bore requirements.

Dimensions		Nominal seal width b	Designations	
Shaft	Bore		Lip material	
d_1	D		R	V
in./mm			–	
23.500 596,90	24.681 626,90	0.591 15,00	CR HDL 3033 R	CR HDL 3033 V
23.562 598,47	25.250 641,35 25.375 644,53	0.750 19,05 0.750 19,05	CR HDL 4290 R CR HDL 4291 R	CR HDL 4290 V CR HDL 4291 V
23.625 600,08	26.000 660,40	0.875 22,23	CR HDL 4292 R	CR HDL 4292 V
23.750 603,25	25.250 641,35	1.000 25,40	CR HDL 6239 R	CR HDL 6239 V
23.875 606,43	26.000 660,40	0.875 22,23	CR HDL 4293 R	CR HDL 4293 V
24.000 609,60	25.500 647,70 26.000 660,40	0.750 19,05 0.813 20,65	CR HDL 4623 R CR HDL 4295 R	CR HDL 4623 V CR HDL 4295 V
24.250 615,95	26.250 666,75	0.875 22,23	CR HDL 4301 R	CR HDL 4301 V
24.437 620,69	26.000 660,40 26.935 684,15	0.750 19,05 1.000 25,40	CR HDL 4302 R CR HDL 9990 R	CR HDL 4302 V CR HDL 9990 V
24.500 622,30	26.500 673,10	0.875 22,23	CR HDL 4305 R	CR HDL 4305 V
25.000 635,00	26.500 673,10	0.750 19,05	CR HDL 4308 R	CR HDL 4308 V
25.187 639,74	26.875 682,63	0.750 19,05	CR HDL 4311 R	CR HDL 4311 V
25.250 641,35	27.250 692,15	0.750 19,05	CR HDL 4299 R	CR HDL 4299 V

Dimensions			Designations	
Shaft	Bore	Nominal seal width	Lip material	
d_1	D	b	R	V
in./mm			-	
25.500 647,70	26.750 679,45 27.500 698,50	0.750 19,05 0.875 22,23	CR HDL 3022 R	CR HDL 3022 V
			CR HDL 4318 R	CR HDL 4318 V
25.750 654,05	27.500 698,50	0.750 19,05	CR HDL 6998 R	CR HDL 6998 V
25.875 657,23	28.000 711,20	0.875 22,23	CR HDL 4303 R	CR HDL 4303 V
25.988 660,09	27.625 701,68	0.750 19,05	CR HDL 4306 R	CR HDL 4306 V
26.000 660,40	27.625 701,68	0.750 19,05	CR HDL 5921 R	CR HDL 5921 V
26.125 663,58	27.625 701,68	0.750 19,05	CR HDL 4329 R	CR HDL 4329 V
26.375 669,93	28.188 715,98	0.875 22,23	CR HDL 4307 R	CR HDL 4307 V
26.500 673,10	28.000 711,20	0.750 19,05	CR HDL 4533 R	CR HDL 4533 V
27.000 685,80	29.000 736,60	0.875 22,23	CR HDL 4333 R	CR HDL 4333 V
27.250 692,15	29.250 742,95	0.875 22,23	CR HDL 4626 R	CR HDL 4626 V
27.500 698,50	29.000 736,60	0.750 19,05	CR HDL 4315 R	CR HDL 4315 V
27.625 701,68	29.625 752,48	0.750 19,05	CR HDL 5001 R	CR HDL 5001 V
27.875 708,03	29.813 757,25	0.875 22,23	CR HDL 4341 R	CR HDL 4341 V
28.000 711,20	29.500 749,30 29.813 757,25	0.750 19,05 0.750 19,05	CR HDL 4343 R	CR HDL 4343 V
			CR HDL 4316 R	CR HDL 4316 V
28.438 722,33	31.000 787,40	0.875 22,23	CR HDL 4321 R	CR HDL 4321 V
28.500 723,90	30.500 774,70	0.875 22,23	CR HDL 4346 R	CR HDL 4346 V
28.750 730,25	30.750 781,05	0.875 22,23	CR HDL 4628 R	CR HDL 4628 V
29.000 736,60	30.500 774,70 31.500 800,10	0.750 19,05 1.000 25,40	CR HDL 4347 R	CR HDL 4347 V
			CR HDL 8793 R	CR HDL 8793 V
29.500 749,30	31.500 800,10 32.000 812,80	0.875 22,23 0.875 22,23	CR HDL 4352 R	CR HDL 4352 V
			CR HDL 4538 R	CR HDL 4538 V

Radial shaft seals – HDL – inch dimensions

d_1 30.000 – 37.000 in.

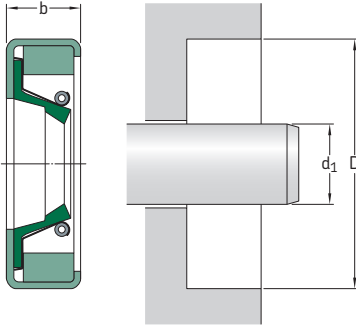

The table includes only a selection of available sizes. Contact your SKF sales representative for more information.

Please see pages 74 to 76 for housing bore requirements.

Dimensions		Nominal seal width b	Designations	
Shaft	Bore		Lip material	
d_1	D		R	V
in./mm			–	
30.000	31.500	0.750	CR HDL 4356 R	CR HDL 4356 V
762,00	800,10	19,05		
	31.625	0.750	CR HDL 7870 R	CR HDL 7870 V
	803,28	19,05		
	32.500	0.875	CR HDL 4358 R	CR HDL 4358 V
	825,50	22,23		
	32.750	0.875	CR HDL 4359 R	CR HDL 4359 V
	831,85	22,23		
30.250	32.500	0.875	CR HDL 4906 R	CR HDL 4906 V
768,35	825,50	22,23		
30.313	32.375	0.875	CR HDL 4361 R	CR HDL 4361 V
769,95	822,33	22,23		
30.500	32.500	0.875	CR HDL 4365 R	CR HDL 4365 V
774,70	825,50	22,23		
31.000	32.500	0.750	CR HDL 5739 R	CR HDL 5739 V
787,40	825,50	19,05		
	33.500	0.875	CR HDL 4540 R	CR HDL 4540 V
	850,90	22,23		
31.250	32.750	0.750	CR HDL 4631 R	CR HDL 4631 V
793,75	831,85	19,05		
31.750	33.750	0.875	CR HDL 5016 R	CR HDL 5016 V
806,45	857,25	22,23		
32.000	33.500	0.750	CR HDL 3023 R	CR HDL 3023 V
812,80	850,90	19,05		
32.125	34.125	0.875	CR HDL 4371 R	CR HDL 4371 V
815,98	866,78	22,23		
	34.125	0.750	CR HDL 3002 R	CR HDL 3002 V
	866,78	19,05		
32.313	34.500	0.875	CR HDL 4373 R	CR HDL 4373 V
820,75	876,30	22,23		
32.500	34.500	0.875	CR HDL 4377 R	CR HDL 4377 V
825,50	876,30	22,22		

Dimensions			Designations	
Shaft	Bore	Nominal seal width	Lip material	
d_1	D	b	R	V
in./mm			-	
32.750 831,85	34.250 869,95	0.750 19,05	CR HDL 4542 R	CR HDL 4542 V
33.000 838,20	34.500 876,30	0.750 19,05	CR HDL 4381 R	CR HDL 4381 V
	34.650 880,10	0.787 20,00	CR HDL 4634 R	CR HDL 4634 V
	35.000 889,00	0.875 22,23	CR HDL 4382 R	CR HDL 4382 V
33.500 850,90	35.000 889,00	0.875 22,23	CR HDL 9504 R	CR HDL 9504 V
	35.625 904,88	0.875 22,23	CR HDL 4548 R	CR HDL 4548 V
33.625 854,08	35.625 904,88	0.875 22,23	CR HDL 4328 R	CR HDL 4328 V
34.000 863,60	35.625 904,88	0.875 22,23	CR HDL 4331 R	CR HDL 4331 V
34.250 869,95	36.000 914,40	0.750 19,05	CR HDL 3017 R	CR HDL 3017 V
	36.750 933,45	0.875 22,23	CR HDL 4335 R	CR HDL 4335 V
34.500 876,30	36.000 914,40	0.750 19,05	CR HDL 6908 R	CR HDL 6908 V
	36.500 927,10	1.000 25,40	CR HDL 3021 R	CR HDL 3021 V
34.750 882,65	36.750 933,45	0.875 22,23	CR HDL 3831 R	CR HDL 3831 V
35.000 889,00	37.000 939,80	0.875 22,23	CR HDL 3835 R	CR HDL 3835 V
35.250 895,35	37.250 946,15	0.875 22,23	CR HDL 4416 R	CR HDL 4416 V
35.375 898,53	37.375 949,33	0.875 22,23	CR HDL 4417 R	CR HDL 4417 V
35.437 900,09	38.583 980,00	0.875 22,23	CR HDL 9079 R	CR HDL 9079 V
35.496 901,60	37.996 965,10	0.984 25,00	CR HDL 3001 R	CR HDL 3001 V
35.500 901,70	37.500 952,50	0.875 22,23	CR HDL 4553 R	CR HDL 4553 V
35.827 910,00	38.077 967,15	0.687 17,45	CR HDL 3003 R	CR HDL 3003 V
36.000 914,40	38.000 965,20	0.875 22,23	CR HDL 4421 R	CR HDL 4421 V
36.500 927,10	38.000 965,20	0.750 19,05	CR HDL 4429 R	CR HDL 4429 V
36.750 933,45	38.750 984,25	0.875 22,23	CR HDL 4432 R	CR HDL 4432 V
37.000 939,80	39.000 990,60	0.875 22,23	CR HDL 4434 R	CR HDL 4434 V

Radial shaft seals – HDL – inch dimensions

d_1 37.250 – 51.250 in.

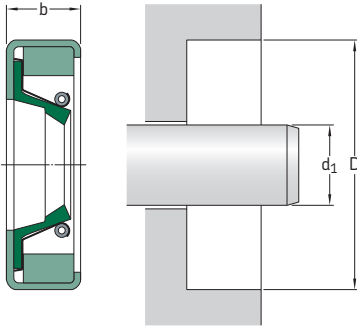

The table includes only a selection of available sizes. Contact your SKF sales representative for more information.

Please see pages 74 to 76 for housing bore requirements.

Dimensions		Nominal seal width b	Designations	
Shaft	Bore		Lip material	
d_1	D		R	V
in./mm			–	
37.250 946,15	39.250 996,95	0.875 22,23	CR HDL 4436 R	CR HDL 4436 V
37.374 949,30	39.500 1 003,30	0.875 22,23	CR HDL 4425 R	CR HDL 4425 V
37.437 950,89	39.500 1 003,30	0.875 22,23	CR HDL 3847 R	CR HDL 3847 V
37.500 952,50	39.000 990,60	0.750 19,05	CR HDL 9411 R	CR HDL 9411 V
38.000 965,20	39.500 1 003,30	0.750 19,05	CR HDL 3004 R	CR HDL 3004 V
	41.000 1 041,40	0.875 22,23	CR HDL 4340 R	CR HDL 4340 V
38.250 971,55	40.250 1 022,35	0.875 22,23	CR HDL 4454 R	CR HDL 4454 V
38.258 971,75	40.750 1 035,05	0.875 22,23	CR HDL 4342 R	CR HDL 4342 V
38.500 977,90	41.000 1 041,40	0.875 22,23	CR HDL 4349 R	CR HDL 4349 V
38.750 984,25	40.750 1 035,05	0.875 22,23	CR HDL 4456 R	CR HDL 4456 V
38.937 988,99	41.000 1 041,40	0.875 22,23	CR HDL 4462 R	CR HDL 4462 V
39.000 990,60	41.000 1 041,40	0.875 22,23	CR HDL 4465 R	CR HDL 4465 V
	42.250 1 073,15	0.875 22,23	CR HDL 4577 R	CR HDL 4577 V
39.750 1 009,65	42.250 1 073,15	0.875 22,23	CR HDL 7538 R	CR HDL 7538 V
40.000 1 016,00	42.000 1 066,80	0.875 22,23	CR HDL 4467 R	CR HDL 4467 V

Dimensions Shaft	Bore	Nominal seal width b	Designations Lip material	
d ₁	D		R	V
in./mm			–	
40.500 1 028,70	42.500 1 079,50	0.875 22,23	CR HDL 4468 R	CR HDL 4468 V
	43.020 1 092,70	0.875 22,23	CR HDL 1964 R	CR HDL 1964 V
41.500 1 054,10	43.500 1 104,90	0.875 22,23	CR HDL 4635 R	CR HDL 4635 V
41.875 1 063,63	43.500 1 104,90	1.000 25,40	CR HDL 8628 R	CR HDL 8628 V
42.248 1 073,10	44.248 1 123,90	1.000 25,40	CR HDL 4470 R	CR HDL 4470 V
42.500 1 079,50	44.250 1 123,95	0.875 22,23	CR HDL 5555 R	CR HDL 5555 V
43.000 1 092,20	45.500 1 155,70	0.875 22,23	CR HDL 7189 R	CR HDL 7189 V
43.500 1 104,90	45.500 1 155,70	0.875 22,23	CR HDL 4637 R	CR HDL 4637 V
43.750 1 111,25	45.750 1 162,05	0.875 22,23	CR HDL 4638 R	CR HDL 4638 V
44.000 1 117,60	46.000 1 168,40	0.875 22,23	CR HDL 7087 R	CR HDL 7087 V
44.500 1 130,30	46.000 1 168,40	0.750 19,05	CR HDL 4563 R	CR HDL 4563 V
46.004 1 168,50	47.500 1 206,50	0.750 19,05	CR HDL 3006 R	CR HDL 3006 V
46.500 1 181,10	48.500 1 231,90	0.875 22,23	CR HDL 4578 R	CR HDL 4578 V
46.850 1 189,99	48.819 1 240,00	0.875 22,23	CR HDL 8317 R	CR HDL 8317 V
48.000 1 219,20	50.000 1 270,00	0.875 22,23	CR HDL 8579 R	CR HDL 8579 V
48.250 1 225,55	50.250 1 276,35	0.875 22,23	CR HDL 4639 R	CR HDL 4639 V
51.248 1 301,71	53.289 1 353,55	0.875 22,23	CR HDL 6747 R	CR HDL 6747 V
51.250 1 301,75	53.300 1 353,82	0.875 22,23	CR HDL 1914 R	CR HDL 1914 V

Radial shaft seals – HDS1, HDS2 and HDS3 – metric dimensions

d_1 170 – 380 mm

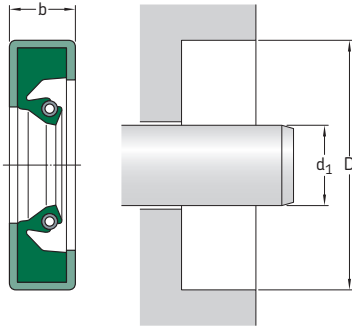

The table includes only a selection of available sizes. Contact your SKF sales representative for more information.

Please see pages 74 to 76 for housing bore requirements.

Dimensions		Nominal seal width b	Design	Lip material	Designation
Shaft	Bore				
d_1	D				
mm					
170	210	16	HDS1	R	CR 170×210×16 HDS1 R
200	230	15,87	HDS1	R	CR 200×230×16 HDS1 R
	238	19	HDS1	V	CR 200×238×19 HDS1 V
	240	20	HDS2	R	CR 200×240×20 HDS2 R
210	245	16	HDS1	R	CR 210×245×16 HDS1 R
	250	20	HDS1	V	CR 210×250×20 HDS1 V
215	270	23	HDS2	R	CR 215×270×23 HDS2 R
220	255	16	HDS1	R	CR 220×255×16 HDS1 R ¹⁾
	260	16	HDS1	R	CR 220×260×16 HDS1 R
	260	20	HDS1	R	CR 220×260×20 HDS1 R
225	257	16	HDS1	R	CR 225×257×16 HDS1 R
230	270	16	HDS2	V	CR 230×270×16 HDS2 V
235	270	16	HDS2	R	CR 235×270×16 HDS2 R
240	280	16	HDS2	R	CR 240×280×16 HDS2 R
	280	16	HDS2	D	CR 240×280×16 HDS2 D
245	305	28	HDS2	R	CR 245×305×28 HDS2 R
250	280	16	HDS2	R	CR 250×280×16 HDS2 R
	280	16	HDS1	D	CR 250×280×16 HDS1 D
	285	16	HDS2	D	CR 250×285×16 HDS2 D
	310	25	HDS1	R	CR 250×310×25 HDS1 R
260	290	16	HDS2	D	CR 260×290×16 HDS2 D
	290	16	HDS2	V	CR 260×290×16 HDS2 V
	300	16	HDS2	R	CR 260×300×16 HDS2 R
	300	20	HDS2	D	CR 260×300×20 HDS2 D
265	310	16	HDS1	R	CR 265×310×16 HDS1 R

¹⁾ 12,7 mm adjustable spacer lugs (4)

Dimensions Shaft	Bore	Nominal seal width b	Design	Lip material	Designation
d_1	D				
mm			–	–	–
270	310	16	HDS3	V	CR 270×310×16 HDS3 V ²⁾
	310	20	HDS2	V	CR 270×310×20 HDS2 V
	330	25	HDS2	V	CR 270×330×25 HDS2 V
275	310	16	HDS1	R	CR 275×310×16 HDS1 R
280	310	16	HDS1	R	CR 280×310×16 HDS1 R
	320	16	HDS1	R	CR 280×320×16 HDS1 R
	320	20	HDS1	R	CR 280×320×20 HDS1 R
	340	25	HDS1	R	CR 280×340×25 HDS1 R
285	320	16	HDS2	R	CR 285×320×16 HDS2 R
	325	16	HDS1	R	CR 285×325×16 HDS1 R
290	330	18	HDS2	R	CR 290×330×18 HDS2 R
	350	25	HDS2	R	CR 290×350×25 HDS2 R
295	335	18	HDS1	R	CR 295×335×18 HDS1 R
300	332	16	HDS2	R	CR 300×332×16 HDS2 R
	335	18	HDS2	R	CR 300×335×18 HDS2 R
	340	18	HDS1	V	CR 300×340×18 HDS1 V
	340	18	HDS1	D	CR 300×340×18 HDS1 D
	340	20	HDS1	V	CR 300×340×20 HDS1 V
	345	22	HDS1	R	CR 300×345×22 HDS1 R
	360	25	HDS2	V	CR 300×360×25 HDS2 V
310	350	18	HDS2	V	CR 310×350×18 HDS2 V
	350	20	HDS2	D	CR 310×350×20 HDS2 D
	370	25	HDS2	D	CR 310×370×25 HDS2 D
315	355	18	HDS1	V	CR 315×355×18 HDS1 V
318	360	20	HDS2	R	CR 318×360×20 HDS2 R
320	350	18	HDS1	R	CR 320×350×18 HDS1 R
	360	18	HDS1	R	CR 320×360×18 HDS1 R
	360	18	HDS2	V	CR 320×360×18 HDS2 V
	380	25	HDS1	R	CR 320×380×25 HDS1 R
330	370	18	HDS1	R	CR 330×370×18 HDS1 R
	390	25	HDS1	R	CR 330×390×25 HDS1 R
335	375	18	HDS3	D	CR 335×375×18 HDS3 D ²⁾
340	380	18	HDS2	V	CR 340×380×18 HDS2 V
	380	18	HDS2	D	CR 340×380×18 HDS2 D
	380	20	HDS2	H	CR 340×380×20 HDS2 H
	380	20	HDS2	R	CR 340×380×20 HDS2 R
350	380	16	HDS2	R	CR 350×380×16 HDS2 R
	390	18	HDS2	D	CR 350×390×18 HDS2 D
360	400	18	HDS1	R	CR 360×400×18 HDS1 R
	400	20	HDS1	V	CR 360×400×20 HDS1 V
	410	17	HDS1	R	CR 360×410×17 HDS1 R
365	405	18	HDS2	R	CR 365×405×18 HDS2 R
370	410	16	HDS2	R	CR 370×410×16 HDS2 R
375	420	18	HDS2	R	CR 375×420×18 HDS2 R
380	420	20	HDS2	R	CR 380×420×20 HDS2 R
	420	20	HDS2	V	CR 380×420×20 HDS2 V
	440	25	HDS2	R	CR 380×440×25 HDS2 R

²⁾ 12,7 mm adjustable spacer lugs (6)

Radial shaft seals – HDS1, HDS2 and HDS3 – metric dimensions

d₁ 390 – 700 mm

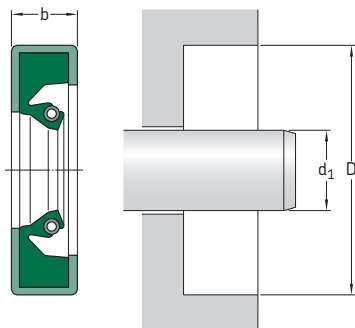

The table includes only a selection of available sizes. Contact your SKF sales representative for more information.

Please see **pages 74 to 76** for housing bore requirements.

Dimensions Shaft	Bore	Nominal seal width	Design	Lip material	Designation
d ₁	D	b			
mm			–	–	–
390	430	16	HDS2	R	CR 390x430x16 HDS2 R
395	430	18	HDS2	R	CR 395x430x18 HDS2 R ²⁾
400	440	20	HDS1	R	CR 400x440x20 HDS1 R
	440	20	HDS2	R	CR 400x440x20 HDS2 R
	460	25	HDS1	R	CR 400x460x25 HDS1 R
410	450	20	HDS2	R	CR 410x450x20 HDS2 R
	460	22	HDS2	R	CR 410x460x22 HDS2 R
420	460	20	HDS2	R	CR 420x460x20 HDS2 R
	470	22	HDS1	R	CR 420x470x22 HDS1 R ¹⁾
430	480	22	HDS1	V	CR 430x480x22 HDS1 V
	480	25	HDS2	R	CR 430x480x25 HDS2 R
435	485	18	HDS2	R	CR 435x485x18 HDS2 R ²⁾
440	470	20	HDS1	R	CR 440x470x20 HDS1 R
	480	20	HDS1	R	CR 440x480x20 HDS1 R
445	485	20	HDS1	R	CR 445x485x20 HDS1 R
450	490	20	HDS1	R	CR 450x490x20 HDS1 R
448	480	16	HDS2	R	CR 448x480x16 HDS2 R
460	500	20	HDS1	R	CR 460x500x20 HDS1 R
	500	20	HDS1	V	CR 460x500x20 HDS1 V
	510	22	HDS2	V	CR 460x510x22 HDS2 V
	520	25	HDS2	R	CR 460x520x25 HDS2 R
470	510	20	HDS1	R	CR 470x510x20 HDS1 R
	530	26	HDS2	R	CR 470x530x26 HDS2 R
480	520	20	HDS1	R	CR 480x520x20 HDS1 R

¹⁾ 12,7 mm adjustable spacer lugs (4)

²⁾ 12,7 mm adjustable spacer lugs (6)

Dimensions Shaft	Bore	Nominal seal width b	Design	Lip material	Designation
d ₁	D				
mm			–	–	–
485	535	22	HDS1	R	CR 485×535×22 HDS1 R
490	530	20	HDS1	R	CR 490×530×20 HDS1 R
500	540 550	20 18	HDS1 HDS1	R R	CR 500×540×20 HDS1 R CR 500×550×18 HDS1 R ²⁾
505	555	20,62	HDS2	R	CR 505×555×21 HDS2 R
510	554	20	HDS1	D	CR 510×554×20 HDS1 D
515	555	20	HDS2	R	CR 515×555×20 HDS2 R
520	560	20	HDS1	R	CR 520×560×20 HDS1 R
525	575	20	HDS3	D	CR 525×575×20 HDS3 D ¹⁾
530	580 580	20 22	HDS1 HDS1	V R	CR 530×580×20 HDS1 V CR 530×580×22 HDS1 R
535	580	20	HDS3	D	CR 535×580×20 HDS3 D ²⁾
540	590	20	HDS2	V	CR 540×590×20 HDS2 V
545	595	22	HDS1	R	CR 545×595×22 HDS1 R
550	590	20	HDS1	R	CR 550×590×20 HDS1 R
560	610	20	HDS1	V	CR 560×610×20 HDS1 V
570	620	22	HDS2	R	CR 570×620×22 HDS2 R ²⁾
580	620	20	HDS3	D	CR 580×620×20 HDS3 D ²⁾
585	620	20	HDS2	R	CR 585×620×20 HDS2 R
590	630	20	HDS1	R	CR 590×630×20 HDS1 R
600	640 650 650	20 22 25	HDS1 HDS2 HDS1	R R V	CR 600×640×20 HDS1 R CR 600×650×22 HDS2 R CR 600×650×25 HDS1 V
610	660	20	HDS2	R	CR 610×660×20 HDS2 R
630	670	20	HDS3	D	CR 630×670×20 HDS3 D ¹⁾
640	690	25	HDS1	R	CR 640×690×25 HDS1 R
650	700 710	22 25	HDS2 HDS2	V R	CR 650×700×22 HDS2 V CR 650×710×25 HDS2 R
660	700	18	HDS1	R	CR 660×700×18 HDS1 R
670	714	20	HDS3	D	CR 670×714×20 HDS3 D ²⁾
680	730	20	HDS2	R	CR 680×730×20 HDS2 R
685	720	20	HDS2	R	CR 685×720×20 HDS2 R
690	730	20	HDS2	R	CR 690×730×20 HDS2 R
695	770	30	HDS1	R	CR 695×770×30 HDS1 R
700	740	20	HDS1	R	CR 700×740×20 HDS1 R

¹⁾ 12,7 mm adjustable spacer lugs (4)

²⁾ 12,7 mm adjustable spacer lugs (6)

Radial shaft seals – HDS1, HDS2 and HDS3 – metric dimensions

d_1 710 – 1 550 mm

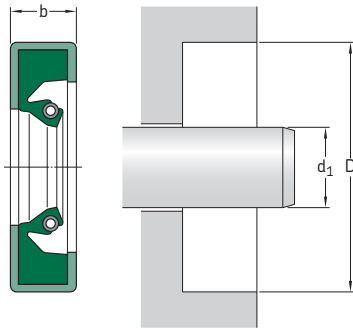

The table includes only a selection of available sizes. Contact your SKF sales representative for more information.

Please see **pages 74 to 76** for housing bore requirements.

Dimensions		Nominal seal width b	Design	Lip material	Designation
Shaft	Bore				
d_1	D				
mm					
710	760	20	HDS1	V	CR 710×760×20 HDS1 V
720	770	25	HDS2	R	CR 720×770×25 HDS2 R
740	780	16,50	HDS1	R	CR 740×780×17 HDS1 R
750	780	18	HDS1	R	CR 750×780×18 HDS1 R
	790	23	HDS1	V	CR 750×790×23 HDS1 V
	800	25	HDS2	R	CR 750×800×25 HDS2 R
	814	25	HDS1	R	CR 750×814×25 HDS1 R ²⁾
760	800	20	HDS1	V	CR 760×800×20 HDS1 V
	810	25	HDS1	R	CR 760×810×25 HDS1 R
770	810	20	HDS1	V	CR 770×810×20 HDS1 V
	845	27,79	HDS1	R	CR 770×845×28 HDS1 R
780	820	19,05	HDS2	R	CR 780×820×19 HDS2 R
790	850	25	HDS1	V	CR 790×850×25 HDS1 V
800	840	20	HDS1	R	CR 800×840×20 HDS1 R
810	860	25	HDS2	R	CR 810×860×25 HDS2 R
825	860	20	HDS2	R	CR 825×860×20 HDS2 R
850	914	25	HDS1	R	CR 850×914×25 HDS1 R
860	920	25	HDS1	R	CR 860×920×25 HDS1 R
880	940	25	HDS2	R	CR 880×940×25 HDS2 R ²⁾
	944	25	HDS3	D	CR 880×944×25 HDS3 D ²⁾
893	925	20	HDS2	H	CR 893×925×20 HDS2 H
900	960	25	HDS1	R	CR 900×960×25 HDS1 R ²⁾

¹⁾ 12,7 mm adjustable spacer lugs (4)

Dimensions Shaft d ₁	Bore D	Nominal seal width b	Design	Lip material	Designation
mm			–	–	–
910	974	22	HDS1	R	CR 910×974×22 HDS1 R ²⁾
920	984	25	HDS2	V	CR 920×984×25 HDS2 V
927	978	22	HDS2	D	CR 927×978×22 HDS2 D
939	971	15,88	HDS3	H	CR 939×971×16 HDS3 H ²⁾
940	1 000	25	HDS1	R	CR 940×1000×25 HDS1 R ¹⁾
950	1 006	20	HDS2	R	CR 950×1006×20 HDS2 R
960	1 020 1 040	25 23	HDS2 HDS2	H V	CR 960×1020×25 HDS2 H CR 960×1040×23 HDS2 V
990	1 045	25	HDS1	R	CR 990×1045×25 HDS1 R
1 000	1 035	20	HDS2	R	CR 1000×1035×20 HDS2 R
1 020	1 084	25	HDS1	R	CR 1020×1084×25 HDS1 R
1 055	1 100	25	HDS2	D	CR 1055×1100×25 HDS2 D
1 105	1 160	25	HDS1	R	CR 1105×1160×25 HDS1 R
1 120	1 184	25	HDS2	R	CR 1120×1184×25 HDS2 R ²⁾
1 140	1 180	20	HDS1	V	CR 1140×1180×20 HDS1 V
1 220	1 255	20	HDS2	R	CR 1220×1255×20 HDS2 R
1 250	1 314	25	HDS2	R	CR 1250×1314×25 HDS2 R
1 260	1 300	18	HDS1	R	CR 1260×1300×18 HDS1 R
1 370	1 420 1 420	19,05 20	HDS2 HDS1	H R	CR 1370×1420×19 HDS2 H CR 1370×1420×20 HDS1 R
1 530	1 580	20	HDS1	R	CR 1530×1580×20 HDS1 R
1 550	1 610	25	HDS2	V	CR 1550×1610×25 HDS2 V

¹⁾ 12,7 mm adjustable spacer lugs (4)

²⁾ 12,7 mm adjustable spacer lugs (6)

Radial shaft seals – HDS1, HDS2 and HDS3 – inch dimensions

d_1 6.000 – 9.750 in.

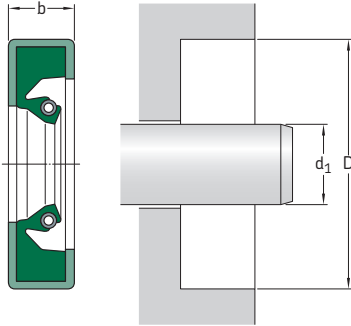

The table includes only a selection of available sizes. Contact your SKF sales representative for more information.

Please see pages 74 to 76 for housing bore requirements.

Dimensions		Nominal seal width b	Design	Lip material	Lug ¹⁾	Designation
Shaft	Bore					
d_1	D					
in./mm			–	–	–	–
6.000 152,40	7.500 190,50	0.625 15,88	HDS1	R		CR 597623
6.750 171,45	7.750 196,85	0.625 15,88	HDS1	V		CR 67512
7.250 184,15	8.750 222,25	0.625 15,88	HDS2	V		CR 72510
7.500 190,50	8.750 222,25	0.625 15,88	HDS1	V		CR 75048
7.750 196,85	9.000 228,60	0.625 15,88	HDS1	R		CR 77531
	9.250 234,95	0.625 15,88	HDS1	V		CR 77539
8.000 203,20	9.250 234,95	0.625 15,88	HDS1	V		CR 77996
	9.500 241,30	0.687 17,45	HDS2	V		CR 80009
	10.000 254,00	1.000 25,40	HDS1	R		CR 80088
8.125 206,38	9.378 238,20	0.625 15,88	HDS1	R		CR 593198
	10.125 257,18	1.000 25,40	HDS1	R		CR 81253
8.250 209,55	9.500 241,30	0.625 15,88	HDS2	V		CR 82526
	10.250 260,35	0.625 15,88	HDS2	V		CR 82559
8.345 211,96	10.750 273,05	1.250 31,75	HDS1	R		CR 594186
8.375 212,73	9.750 247,65	0.625 15,88	HDS3	D	4	CR 83702

¹⁾ Number of 0,5 in. adjustable spacer lugs

Dimensions Shaft d ₁	Bore D	Nominal seal width b	Design	Lip material	Lug ¹⁾	Designation
in./mm			-	-	-	-
8.500 215,90	9.750 247,65	0.625 15,88	HDS2	D		CR 593768
	10.500 266,70	0.625 15,88	HDS1	V		CR 85018
8.540 215,90	9.750 247,65	0.625 15,88	HDS2	D		CR 593855
8.625 219,08	10.500 266,70	0.750 19,05	HDS1	R		CR 590758
	10.625 269,88	0.750 19,05	HDS1	V		CR 86240
8.750 222,25	10.000 254,00	0.625 15,88	HDS2	R		CR 592626
8.875 225,43	10.125 257,18	0.625 15,88	HDS2	D		CR 593779
9.000 228,60	10.250 260,35	0.750 19,05	HDS1	R		CR 90017
	10.500 266,70	0.625 15,88	HDS3	D	4	CR 90027
	11.000 279,40	0.750 19,05	HDS2	R		CR 590787
9.125 231,78	10.375 263,53	0.625 15,88	HDS1	R		CR 592653
	10.625 269,88	0.688 17,48	HDS1	R		CR 590270
	11.125 282,58	0.688 17,48	HDS1	R		CR 590174
	11.125 282,50	0.813 20,65	HDS2	R		CR 91202
9.250 234,95	10.750 273,05	0.750 19,05	HDS1	R		CR 590093
	11.250 285,75	0.813 20,65	HDS2	V		CR 92544
	11.250 285,75	1.000 25,40	HDS1	R		CR 590798
9.375 238,13	11.375 288,93	0.875 22,23	HDS1	R		CR 93751
9.438 239,73	10.635 270,13	0.750 19,05	HDS1	R		CR 593894
9.500 241,30	10.750 273,05	0.625 15,88	HDS2	R		CR 95045
	11.000 279,40	0.625 15,88	HDS1	R		CR 590653
	11.500 292,10	0.813 20,65	HDS1	V		CR 95068
	11.500 292,10	1.000 25,40	HDS1	R		CR 590820
9.688 246,08	10.875 276,23	0.625 15,88	HDS1	R		CR 594080
9.750 247,65	11.000 279,40	0.625 15,88	HDS3	D	4	CR 97527
	11.750 298,45	1.000 25,40	HDS1	R		CR 97548

¹⁾ Number of 0,5 in. adjustable spacer lugs

Radial shaft seals – HDS1, HDS2 and HDS3 – inch dimensions

d_1 9.844 – 11.813 in.

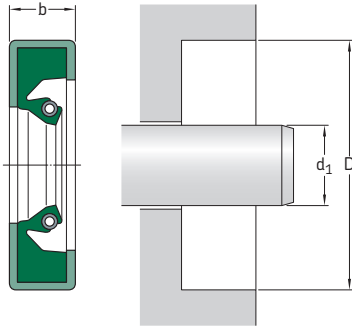

The table includes only a selection of available sizes. Contact your SKF sales representative for more information.

Please see pages 74 to 76 for housing bore requirements.

Dimensions Shaft	Bore	Nominal seal width	Design	Lip material	Lug ¹⁾	Designation
d_1	D	b				
in./mm			–	–	–	–
9.844 250,04	11.409 289,79	0.625 15,88	HDS2	R		CR 98444
9.875 250,83	11.375 288,93	0.750 19,05	HDS2	R		CR 592763
	11.500 292,10	0.750 19,05	HDS1	R		CR 592727
9.938 252,43	12.000 304,80	1.000 25,40	HDS2	R		CR 529752
10.000 254,00	11.250 285,75	0.625 15,88	HDS1	R		CR 1000110
	11.250 285,75	0.625 15,88	HDS2	R		CR 1000111
	11.500 292,10	0.625 15,88	HDS3	D	4	CR 1000239
	11.750 298,45	0.625 15,88	HDS1	R		CR 1000360
	11.625 295,28	0.688 17,48	HDS1	R		CR 1013240
	11.625 295,28	0.688 17,48	HDS2	R		CR 1013242
10.236 259,99	12.590 319,79	0.984 24,99	HDS1	R		CR 1024690
10.250 260,35	11.500 292,10	0.625 15,88	HDS2	D		CR 1025112
	11.750 298,45	0.688 17,48	HDS3	D	4	CR 1025249
	11.750 298,45	0.750 19,05	HDS2	R		CR 1025252
	11.625 295,28	0.875 22,23	HDS1	R		CR 1038140

¹⁾ Number of 0,5 in. adjustable spacer lugs

Dimensions Shaft d ₁	Bore D	Nominal seal width b	Design	Lip material	Lug ¹⁾	Designation
in./mm			-	-	-	-
10.438 265,13	12.438 315,93	0.875 22,23	HDS1	R		CR 1044560
10.500 266,70	11.750 298,45	0.625 15,88	HDS1	V		CR 1050113
	12.000 304,80	0.625 15,88	HDS3	D	4	CR 1050239
	12.000 304,80	0.750 19,05	HDS2	V		CR 1050251
10.688 271,48	12.500 317,50	0.625 15,88	HDS1	V		CR 1068456
	13.000 330,20	0.688 17,48	HDS2	V		CR 1068693
10.750 273,05	12.000 304,80	0.625 15,88	HDS2	R		CR 1075112
	12.000 304,80	0.625 15,88	HDS1	R		CR 1075110
	12.250 311,15	0.625 15,88	HDS1	R		CR 1075230
10.938 277,83	12.750 323,85	0.625 15,88	HDS1	R		CR 1093440
11.000 279,40	12.250 311,15	0.625 15,88	HDS2	D		CR 1100113
	12.250 311,15	0.625 15,88	HDS2	V		CR 1100104
	12.500 317,50	0.750 19,05	HDS1	R		CR 1100250
	13.000 330,20	0.813 20,65	HDS2	R		CR 1100553
11.250 285,75	12.500 317,50	0.625 15,88	HDS2	R		CR 1125111
	12.500 317,50	0.625 15,88	HDS1	R		CR 1125110
11.375 288,93	13.000 330,20	0.750 19,05	HDS1	R		CR 1138330
11.500 292,10	13.000 330,20	0.750 19,05	HDS2	R		CR 1150253
	13.500 342,90	0.813 20,65	HDS1	R		CR 1150550
	13.500 342,90	1.000 25,40	HDS1	R		CR 1150580
11.688 296,88	12.938 328,63	0.625 15,88	HDS1	R		CR 1169110
11.750 298,45	13.250 336,55	0.688 17,48	HDS2	V		CR 1175224
	13.250 336,55	0.750 19,05	HDS2	R		CR 1175252
11.811 300,00	13.378 339,80	0.709 18,01	HDS1	R		CR 1181300
11.813 300,05	13.812 350,82	0.875 22,23	HDS1	R		CR 1181560

¹⁾ Number of 0,5 in. adjustable spacer lugs

Radial shaft seals – HDS1, HDS2 and HDS3 – inch dimensions

d_1 12.000 – 15.250 in.

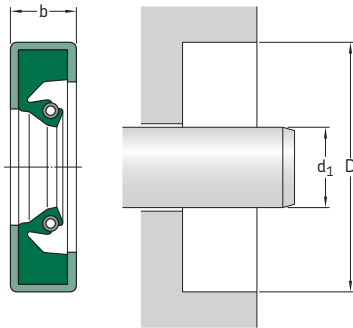

The table includes only a selection of available sizes. Contact your SKF sales representative for more information.

Please see pages 74 to 76 for housing bore requirements.

Dimensions Shaft	Bore	Nominal seal width b	Design	Lip material	Lug ¹⁾	Designation
d_1	D	b				
in./mm						
12.000 304,80	13.500	0.625	HDS2	R		CR 1200231
	342,90	15,88				
	13.500	0.625	HDS1	R		CR 1200230
	342,90	15,88				
	13.500	0.625	HDS3	D	4	CR 1200239
	342,90	15,88				
	13.500	0.688	HDS1	R		CR 1200240
	342,90	17,48				
	13.500	0.750	HDS2	R		CR 1200255
	342,90	19,05				
12.250 311,15	14.000	0.625	HDS1	V		CR 1200523
	355,60	15,88				
	14.000	1.000	HDS2	R		CR 1200585
	355,60	25,40				
	13.750	0.625	HDS3	D	4	CR 1225239
349,25	15,88					
12.500 317,50	13.750	0.625	HDS1	R		CR 1250110
	349,25	15,88				
	14.000	0.688	HDS3	D	4	CR 1250249
	355,60	17,48				
	14.500	0.750	HDS1	R		CR 1250540
	368,30	19,05				
	14.500	0.813	HDS2	V		CR 1250554
	368,30	20,65				
12.750 323,85	14.250	0.688	HDS2	V		CR 1275243
	361,95	17,48				
	14.250	0.750	HDS2	R		CR 1275252
	361,95	19,05				
13.000 330,20	14.500	0.688	HDS2	R		CR 1300244
	368,30	17,48				
	14.500	0.688	HDS2	V		CR 1300283
	368,30	17,48				
	15.000	0.750	HDS2	R		CR 1300542
381,00	19,05					

¹⁾ Number of 0,5 in. adjustable spacer lugs

Dimensions Shaft d ₁	Bore D	Nominal seal width b	Design	Lip material	Lug ¹⁾	Designation
in./mm			-	-	-	-
13.250 336,55	14.750 374,65	0.625 15,88	HDS3	D	4	CR 1325239
	14.750 374,65	0.688 17,48	HDS2	R		CR 1325242
13.500 342,90	15.250 387,35	0.750 19,05	HDS1	R		CR 1350380
	15.500 393,70	0.813 20,65	HDS2	V		CR 1350564
13.750 349,25	15.000 381,00	0.750 19,05	HDS1	R		CR 1375130
	15.250 387,35	0.625 15,88	HDS1	R		CR 1375230
	15.250 387,35	0.688 17,48	HDS1	R		CR 1375240
	15.500 393,70	0.750 19,05	HDS1	R		CR 1375380
	15.750 400,05	0.813 20,65	HDS2	V		CR 1375553
14.000 355,60	15.500 393,70	0.625 15,88	HDS2	V		CR 1400234
	15.500 393,70	0.625 15,88	HDS2	R		CR 1400232
	15.500 393,70	0.750 19,05	HDS1	R		CR 1400250
	15.750 400,05	0.688 17,48	HDS1	R		CR 1400370
	16.000 406,40	1.000 25,40	HDS1	R		CR 1400580
14.250 361,95	15.750 400,05	0.750 19,05	HDS2	R		CR 1425252
	16.250 412,75	0.813 20,65	HDS2	R		CR 1425552
14.375 365,13	16.000 406,40	0.688 17,48	HDS2	D		CR 1438321
14.500 368,30	16.000 406,40	0.688 17,48	HDS2	R		CR 1450242
	16.500 419,10	0.750 19,05	HDS2	R		CR 1450542
14.750 374,65	16.500 419,10	0.875 22,23	HDS2	R		CR 1475411
15.000 381,00	16.500 419,10	0.688 17,48	HDS1	R		CR 1500240
	16.500 419,10	0.750 19,05	HDS1	R		CR 1500250
	16.750 425,45	0.750 19,05	HDS1	R		CR 1500380
	17.000 431,80	0.750 19,05	HDS3	D	4	CR 1500549
15.250 387,35	16.750 425,45	0.750 19,05	HDS2	R		CR 1525252
	17.250 438,15	0.750 19,05	HDS2	R		CR 1525542
	17.250 438,15	0.875 22,23	HDS1	R		CR 1525560

¹⁾ Number of 0,5 in. adjustable spacer lugs

Radial shaft seals – HDS1, HDS2 and HDS3 – inch dimensions

d_1 15.500 – 22.250 in.

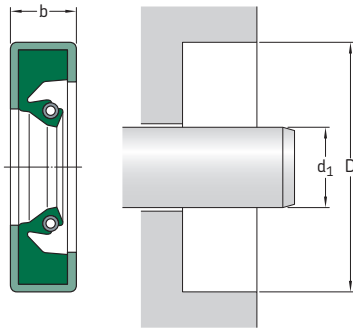

The table includes only a selection of available sizes. Contact your SKF sales representative for more information.

Please see pages 74 to 76 for housing bore requirements.

Dimensions Shaft	Bore	Nominal seal width b	Design	Lip material	Lug ¹⁾	Designation
d_1	D					
in./mm						
15.500	16.875	0.625	HDS1	R		CR 1550160
393,70	428,63	15,88				
	17.500	0.750	HDS2	R		CR 1550542
	444,50	19,05				
	17.500	0.813	HDS1	R		CR 1550550
	444,50	20,65				
15.625	17.625	0.875	HDS1	R		CR 1563560
396,88	447,68	22,23				
15.750	17.250	0.688	HDS3	D	4	CR 1575249
400,05	438,15	17,48				
16.000	17.500	0.750	HDS1	R		CR 1600250
406,40	444,50	19,05				
	18.000	1.000	HDS2	R		CR 1600585
	457,20	25,40				
16.250	17.750	0.688	HDS1	R		CR 1625240
412,75	450,85	17,48				
16.500	18.000	0.750	HDS2	R		CR 1650252
419,10	457,20	19,05				
16.750	18.500	0.875	HDS1	V		CR 1675413
425,45	469,90	22,23				
17.000	18.500	0.688	HDS2	R		CR 1700245
431,80	469,90	17,48				
	18.500	0.750	HDS2	D		CR 1700251
	469,90	19,05				
	19.000	0.750	HDS2	R		CR 1700541
	482,60	19,05				
17.250	18.750	0.750	HDS2	R		CR 1725255
438,15	476,25	19,05				

¹⁾ Number of 0,5 in. adjustable spacer lugs

Dimensions Shaft d ₁	Bore D	Nominal seal width b	Design	Lip material	Lug ¹⁾	Designation
in./mm			-	-	-	-
17.500 444,50	19,000 482,60	0.625 15,88	HDS1	R		CR 1750230
	19,250 488,95	0.688 17,48	HDS1	R		CR 1750370
	19,500 495,30	0.688 17,48	HDS1	R		CR 1750530
17.625 447,68	19,250 488,95	0.688 17,48	HDS1	R		CR 1763320
18.000 457,20	19,500 495,30	0.688 17,48	HDS3	D	4	CR 1800249
	19,750 501,65	0.750 19,05	HDS2	R		CR 1800382
18.250 463,55	19,750 501,65	0.750 19,05	HDS2	R		CR 1825252
18.500 469,90	20,500 520,70	0.875 22,23	HDS1	R		CR 1850560
18.750 476,25	20,750 527,05	0.813 20,65	HDS2	R		CR 1875553
19.000 482,60	20,500 520,70	0.750 19,05	HDS1	R		CR 1900250
	21,000 533,40	0.875 22,23	HDS2	V		CR 1900562
19.250 488,95	21,250 539,75	0.938 23,24	HDS1	R		CR 1925570
19.500 495,30	21,500 546,10	0.875 22,23	HDS1	R		CR 1950560
20.000 508,00	21,500 546,10	0.625 15,88	HDS3	D	4	CR 2000239
20.250 514,35	21,750 552,45	0.750 19,05	HDS1	R		CR 2025250
20.500 520,70	22,500 571,50	0.750 19,05	HDS2	R		CR 2050542
	22,500 571,50	0.875 22,23	HDS1	R		CR 2050560
20.750 527,05	22,750 577,85	0.875 22,23	HDS2	D		CR 2075562
21.000 533,40	22,750 577,85	0.813 20,65	HDS1	R		CR 2100390
	23,000 584,20	0.625 15,87	HDS3	D	4	CR 2100529
21.500 546,10	23,500 596,90	0.813 20,65	HDS1	R		CR 2150550
22.000 558,80	23,500 596,90	0.750 15,88	HDS2	V		CR 2200213
	24,000 609,60	0.875 22,23	HDS2	R		CR 2200565
	24,000 609,60	1.250 31,75	HDS1	D		CR 526339
22.250 565,15	24,250 615,95	0.875 22,23	HDS3	H	4	CR 2225568

¹⁾ Number of 0,5 in. adjustable spacer lugs

Radial shaft seals – HDS1, HDS2 and HDS3 – inch dimensions

d_1 23.000 – 63.340 in.

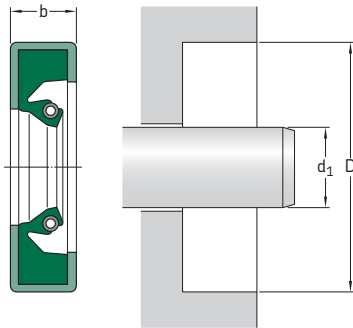

The table includes only a selection of available sizes. Contact your SKF sales representative for more information.

Please see pages 74 to 76 for housing bore requirements.

Dimensions Shaft	Bore	Nominal seal width b	Design	Lip material	Lug ¹⁾	Designation
d_1	D					
in./mm			–	–	–	–
23.000 584,20	24.750 628,65	0.750 19,05	HDS2	V		CR 2300384
23.500 596,90	25.500 647,70	0.875 22,23	HDS1	R		CR 2350560
24.000 609,60	25.500 647,70	0.750 19,05	HDS1	R		CR 2400250
		26.000 660,40	HDS2	R		CR 2400559
24.250 615,95	26.250 666,75	0.875 22,23	HDS2	V		CR 2425562
25.000 635,00	27.000 685,80	1.000 25,40	HDS1	R		CR 2500580
25.500 647,70	27.500 698,50	1.000 25,40	HDS2	R		CR 2550585
26.000 660,40	27.625 701,68	0.750 19,05	HDS2	R		CR 2600332
		28.500 723,90	HDS1	R		CR 2600760
26.500 673,10	28.500 723,90	0.875 22,23	HDS1	R		CR 2650560
28.000 711,20	29.625 752,48	0.750 19,05	HDS2	R		CR 2800331
		30.000 762,00	HDS2	R		CR 2800565
29.000 736,60	31.000 787,40	0.875 22,23	HDS2	R		CR 2900563
29.500 749,30	31.500 800,10	0.875 22,23	HDS2	D		CR 2950564

¹⁾ Number of 0,5 in. adjustable spacer lugs

Dimensions Shaft d ₁	Bore D	Nominal seal width b	Design	Lip material	Lug ¹⁾	Designation
in./mm			-	-	-	-
30.250 768,35	32.500 825,50	0.875 22,23	HDS1	R		CR 3025660
30.500 774,70	32.500 825,50	0.875 22,23	HDS2	V		CR 3050514
	33.000 838,20	1.000 25,40	HDS2	R		CR 3050785
31.000 787,40	33.000 838,20	0.813 20,65	HDS1	R		CR 3100550
32.500 825,50	34.500 876,30	0.875 22,23	HDS1	R		CR 3250560
33.000 838,20	34.688 881,08	0.750 19,05	HDS2	R		CR 3300351
33.500 850,90	36.000 914,40	0.875 22,23	HDS1	R		CR 3350760
34.000 863,60	36.000 914,40	0.875 22,23	HDS1	R		CR 3400560
34.500 876,30	36.500 927,10	0.875 22,23	HDS2	D		CR 3450563
37.500 952,50	39.000 990,60	0.875 22,23	HDS2	R		CR 3750272
	39.500 1 003,30	0.875 22,23	HDS1	D		CR 3750561
38.000 965,20	40.000 1 016,00	0.875 22,23	HDS2	R		CR 3800565
40.500 1 028,70	43.000 1 092,20	0.875 22,23	HDS2	V		CR 4050774
43.500 1 104,90	45.500 1 155,70	0.875 22,23	HDS2	R		CR 4350565
	45.500 1 155,70	0.875 22,23	HDS1	R		CR 4350560
45.000 1 143,00	47.000 1 193,80	0.875 22,23	HDS1	R		CR 4500560
46.000 1 168,40	47.500 1 206,50	0.750 19,05	HDS2	H		CR 4600252
49.000 1 244,60	50.625 1 285,88	0.813 20,65	HDS1	R		CR 4900340
51.500 1 308,10	53.500 1 358,90	1.500 38,10	HDS1	R		CR 5150590
54.750 1 390,65	56.375 1 431,93	0.875 22,23	HDS1	R		CR 5475340
62.500 1 587,50	64.000 1 625,60	0.875 22,23	HDS1	R		CR 6250270
63.340 1 608,84	64.500 1 638,30	0.750 19,05	HDS2	D		CR 6334342

¹⁾ Number of 0,5 in. adjustable spacer lugs

Radial shaft seals – HDS1K – inch dimensions

d_1 7.939 in.

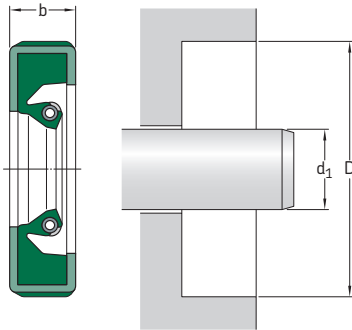

The table includes only a selection of available sizes. Contact your SKF sales representative for more information.

Please see **pages 74 to 76** for housing bore requirements.

Dimensions		Nominal seal width b	Design	Lip material	Designation
Shaft	Bore				
d_1	D				
in./mm			–	–	–
7.939 201,65	10,125 257,18	0,688 17,48	HDS1K	H	CR 597606

Radial shaft seals – HDS2K – metric dimensions

d_1 340 – 810 mm

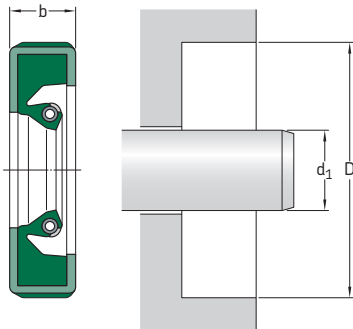

The table includes only a selection of available sizes. Contact your SKF sales representative for more information.

Please see **pages 74 to 76** for housing bore requirements.

Dimensions			Design	Lip material	Designation
Shaft	Bore	Nominal seal width			
d_1	D	b			
mm			–	–	–
340	380	18	HDS2K	V	CR 340×380×18 HDS2K V
360	404	20	HDS2K	R	CR 360×404×20 HDS2K R
400	450	18	HDS2K	R	CR 400×450×18 HDS2K R
810	874	25	HDS2K	R	CR 810×874×25 HDS2K R

Radial shaft seals – HDS2K – inch dimensions
 d_1 16.500 in.

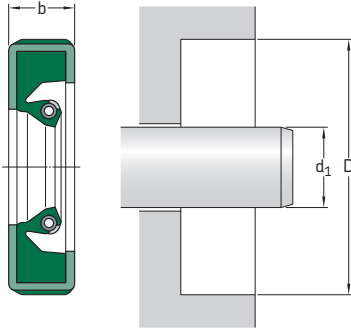

The table includes only a selection of available sizes. Contact your SKF sales representative for more information.

2.14

Please see pages 74 to 76 for housing bore requirements.

Dimensions		Nominal seal width b	Design	Lip material	Designation
Shaft	Bore				
d_1	D				
in./mm			–	–	–
16,500 419,10	18,000 457,20	0.750 19,05	HDS2K	R	CR 1650230

Radial shaft seals – HDSF and HDSH seals – metric dimensions

d_1 440 – 760 mm

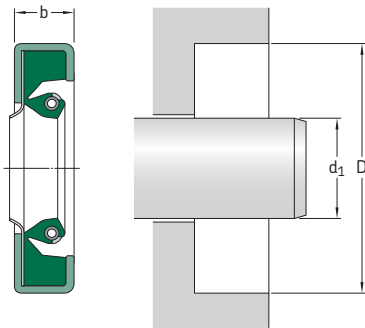

The table includes only a selection of available sizes. Contact your SKF sales representative for more information.

Please see pages 74 to 76 for housing bore requirements.

Dimensions		Nominal seal width b	Design	Lip material	Designation
Shaft	Bore				
d_1	D				
mm			–	–	–
440	490	20,40	HDSF2	VT	CR 440×490×20 HDSF2 VT
	490	20,40	HDSH7	HT	CR 440×490×20 HDSH7 HT
500	540	20	HDSF2	RT	CR 500×540×20 HDSF2 RT
760	800	20	HDSF2	HT	CR 760×800×20 HDSF2 HT
	800	20	HDSF7	HT	CR 760×800×20 HDSF7 HT

Radial shaft seals – HDSF and HDSH seals – inch dimensions

d_1 10.500 – 31.890 in.

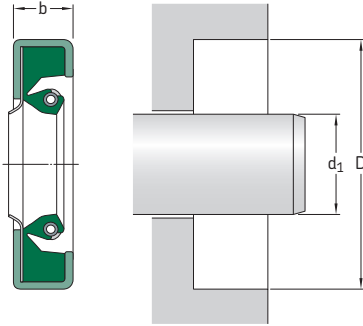

The table includes only a selection of available sizes. Contact your SKF sales representative for more information.

2.15

Please see **pages 74 to 76** for housing bore requirements.

Dimensions		Nominal seal width b	Design	Lip material	Designation
Shaft	Bore				
d_1	D				
in./mm			–	–	–
10.500 266,70	12.500 317,50	1.000 25,40	HDSF1	VT	CR 1050966
14.000 355,60	16.000 406,40	1.000 25,40	HDSF1	VT	CR 1400957
15.500 393,70	17.500 444,50	0.750 19,05	HDSH7	RT	CR 1550951
	17.500 444,50	0.750 19,05	HDSF2	HT	CR 1550952
16.000 406,40	18.000 457,20	0.875 22,23	HDSF2	HT	CR 1600510
18.500 469,90	20.500 520,70	0.875 22,23	HDSF2	DT	CR 1850953
19.000 482,60	21.000 533,40	0.870 22,10	HDSF2	VT	CR 1900954
31.890 810,01	34.409	0.921	HDSF2	VT	CR 3189981
	873,99	23,39			
	34.409	0.921	HDSH7	HT	CR 3189988
	873,99	23,39			

Radial shaft seals – HDSA, HDSB and HDSC seals – metric dimensions

d_1 240 – 790 mm

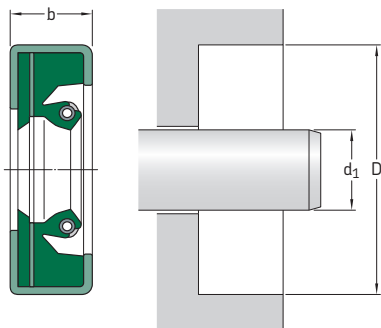

The table includes only a selection of available sizes. Contact your SKF sales representative for more information.

Please see **pages 74 to 76** for housing bore requirements.

Dimensions Shaft	Bore	Nominal seal width b	Design	Lip material	Designation
d_1	D				
mm			–	–	–
240	280	23	HDSA1	RD	CR 240x280x23 HDSA1 RD
270	330	25,40	HDSA1	RD	CR 270x330x25 HDSA1 RD
310	370	25,40	HDSA1	RD	CR 310x370x25 HDSA1 RD
317	352	23	HDSA1	RD	CR 317x352x23 HDSA1 RD
320	360	22,23	HDSC1	VD	CR 320x360x22 HDSC1 VD
	360	25	HDSB2	RD	CR 320x360x25 HDSB2 RD
	380	28	HDSA2	RD	CR 320x360x28 HDSA2 RD
364	420	25	HDSA2	RD	CR 364x420x25 HDSA2 RD
380	420	22,20	HDSA2	VD	CR 380x420x22 HDSA2 VD
	440	28	HDSA2	RD	CR 380x440x28 HDSA2 RD
390	434	22	HDSA2	VD	CR 390x434x22 HDSA2 VD
400	460	28	HDSA2	RD	CR 400x460x28 HDSA2 RD
420	460	22,23	HDSC1	VD	CR 420x460x22 HDSC1 VD
430	470	20	HDSB1	RD	CR 430x470x20 HDSB1 RD
440	480	22,23	HDSA2	VD	CR 440x480x22 HDSA2 VD
560	620	30	HDSA2	RD	CR 560x620x30 HDSA2 RD
580	640	30	HDSA2	RD	CR 580x640x30 HDSA2 RD
	640	30	HDSB1	RD	CR 580x640x30 HDSB1 RD
790	850	25	HDSA1	RD	CR 790x850x25 HDSA1 RD

Radial shaft seals – HDSA, HDSB and HDSC seals – inch dimensions

d_1 6.000 – 9.625 in.

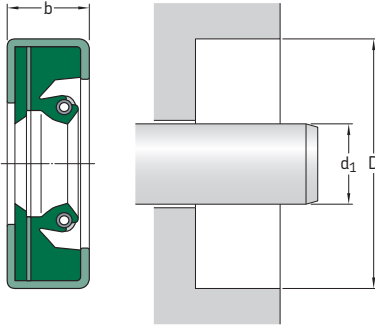

The table includes only a selection of available sizes. Contact your SKF sales representative for more information.

Please see pages 74 to 76 for housing bore requirements.

Dimensions			Design	Lip material	Designation	
Shaft	Bore	Nominal seal width				
d_1	D	b				
in./mm						
6.000 152,40	7.500 190,50	0.750 19,05	HDSA1	RD	CR 597625	
6.625 168,28	8.125 206,38	0.875 22,23	HDSA2	VD	CR 594828	
7.250 184,15	8.750 222,25	0.875 22,23	HDSA2	VD	CR 72594	
8.000 203,20	10.000 254,00	1.000 25,40	HDSB1	RD	CR 592328	
	10.000 254,00	1.250 31,75	HDSC1	RD	CR 590727	
	10.000 254,00	1.250 31,75	HDSA1	RD	CR 592336	
	10.125 257,18	1.250 31,75	HDSB1	RD	CR 80092	
8.250 209,55	10.250 260,35	0.875 22,23	HDSB1	RD	CR 591921	
	10.250 260,35	1.250 31,75	HDSB1	RD	CR 590357	
	8.500 215,90	9.750 247,65	0.870 22,10	HDSA2	CR 595513	
8.500 215,90	10.000 254,00	0.875 22,23	HDSA1	VD	CR 596196	
	10.000 254,00	1.000 25,40	HDSA1	RD	CR 590731	
	10.500 266,70	0.875 22,23	HDSA1	VD	CR 592798	
	10.500 266,70	1.000 25,40	HDSB1	RD	CR 592149	
	10.500 266,70	1.000 25,40	HDSA2	VD	CR 594902	
	10.500 266,70	1.250 31,75	HDSA1	RD	CR 590245	
	8.750 222,25	10.250 260,35	0.875 22,23	HDSC1	RD	CR 594333
		10.750 273,05	0.875 22,23	HDSA1	RD	CR 592492

Dimensions			Design	Lip material	Designation	
Shaft	Bore	Nominal seal width				
d_1	D	b				
in./mm						
8.875 225,43	10.125 257,18	0.875 22,23	HDSA2	DD	CR 595127	
	10.875 276,23	0.875 22,23	HDSA1	RD	CR 591984	
	11.250 285,75	0.875 22,23	HDSA1	RD	CR 592464	
	9.000 228,60	10.250 260,35	0.875 22,23	HDSA2	VD	CR 90054
9.000 228,60	10.500 266,70	0.875 22,23	HDSA1	RD	CR 597343	
	11.000 279,40	1.000 25,40	HDSA2	VD	CR 594903	
	9.250 234,95	10.438 265,13	0.875 22,23	HDSA1	RD	CR 92591
		11.000 279,40	1.375 34,93	HDSA1	RD	CR 592452
11.250 285,75		0.875 22,23	HDSA1	VD	CR 593312	
9.375 238,13	12.750 323,85	1.250 31,75	HDSB1	RD	CR 590688	
	9.500 241,30	11.500 292,10	1.250 31,75	HDSA2	RD	CR 590375
11.500 292,10		1.250 31,75	HDSC1	DD	CR 591960	
11.500 292,10		1.250 31,75	HDSA2	DD	CR 593667	
9.620 244,35		12.750 323,85	1.250 31,75	HDSA1	RD	CR 96290
	9.625 244,48	11.625 295,28	1.000 25,40	HDSC1	RD	CR 593659

Radial shaft seals – HDSA, HDSB and HDSC seals – inch dimensions

d_1 9.750 – 14.500 in.

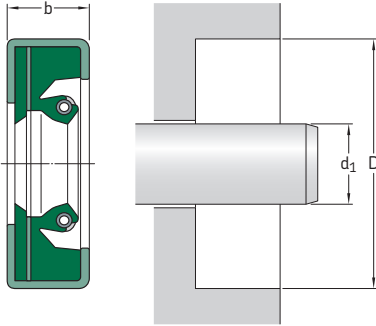

The table includes only a selection of available sizes. Contact your SKF sales representative for more information.

Dimensions			Design	Lip material	Designation
Shaft	Bore	Nominal seal width			
d_1	D	b	-	-	-
in./mm					
9.750 247,65	11.000 279,40	0.875 22,23	HDSA1	RD	CR 593053
	11.000 279,40	1.000 25,40	HDSA1	DD	CR 593428
	11.125 282,58	0.875 22,23	HDSA2	DD	CR 594974
	11.250 285,75	0.875 22,23	HDSA2	DD	CR 595514
	11.750 298,45	1.000 25,40	HDSA1	DD	CR 595568
9.844 250,04	11.409 289,79	0.875 22,23	HDSC2	RD	CR 595219
9.875 250,83	11.875 301,63	1.000 25,40	HDSA2	RD	CR 592847
10.000 254,00	11.250 285,75	0.875 22,23	HDSA1	RD	CR 1000910
	11.250 285,75	0.875 22,23	HDSA2	VD	CR 1000914
	11.500 292,10	1.250 31,75	HDSA1	RD	CR 1000920
	11.750 298,45	0.938 23,83	HDSC2	DD	CR 1000943
	11.750 298,45	1.000 25,40	HDSC1	RD	CR 1000941
	12.000 304,80	0.875 22,23	HDSA1	RD	CR 1000950
	12.000 304,80	1.250 31,75	HDSA1	RD	CR 1000952
	12.000 304,80	1.250 31,75	HDSB1	RD	CR 1000953
	12.000 304,80	1.500 38,10	HDSA1	RD	CR 1000954
	12.500 317,50	1.000 25,40	HDSA1	RD	CR 1000971
10.125 257,18	11.750 298,45	0.938 23,83	HDSC1	RD	CR 1013930

Dimensions			Design	Lip material	Designation
Shaft	Bore	Nominal seal width			
d_1	D	b	-	-	-
in./mm					
10.250 260,35	12.250 311,15	1.250 31,75	HDSC1	RD	CR 1025951
10.375 263,53	11.625 295,28	0.875 22,23	HDSA2	DD	CR 1037912
10.500 266,70	12.000 304,80	0.875 22,23	HDSC1	RD	CR 1050916
	12.500 317,50	1.000 25,40	HDSA1	RD	CR 1050956
	12.500 317,50	1.000 25,40	HDSB1	RD	CR 1050958
	12.500 317,50	1.000 25,40	HDSA1	VT	CR 1050966
10.625 269,88	12.500 317,50	0.969 24,61	HDSA1	RD	CR 1062945
	13.000 330,20	1.000 25,40	HDSB1	RD	CR 1063971
10.688 271,48	12.500 317,50	1.000 25,40	HDSA1	RD	CR 1068940
10.750 273,05	12.250 311,15	0.875 22,23	HDSC1	RD	CR 1075928
	12.250 311,15	1.025 26,04	HDSC1	RD	CR 1075910
	12.500 317,50	0.875 22,23	HDSA2	RD	CR 1075942
	13.371 339,62	1.250 31,75	HDSB1	RD	CR 1075991

Dimensions			Design	Lip material	Designation	
Shaft	Bore	Nominal seal width				
d_1	D	b	-	-	-	
in./mm			-	-	-	
11.000 279,40	12.500	1.250	HDSA1	RD	CR 1100918	
	317,50	31,75				
	13.000	0.875	HDSA1	RD	CR 1100950	
	330,20	22,23				
	13.000	1.000	HDSA1	RD	CR 1100951	
	330,20	25,40				
	13.000	1.250	HDSA1	RD	CR 1100952	
	330,20	31,75				
	13.000	1.250	HDSB1	RD	CR 1100953	
	330,20	31,75				
11.417 290,00	13.000	1.250	HDSC1	RD	CR 1100954	
	330,20	31,75				
	13.500	1.250	HDSA1	RD	CR 1100971	
	342,90	31,75				
	12.994	0.875	HDSA1	VD	CR 1141937	
	330,00	22,23				
	13.000	0.875	HDSA2	VD	CR 1141273	
	330,20	22,23				
	11.500 292,10	13.000	0.750	HDSA1	RD	CR 115025
		330,20	19,05			
13.000		0.875	HDSA1	DD	CR 1150925	
330,20		22,23				
13.000		1.063	HDSA1	RD	CR 1150920	
330,20	27,00					
11.750 298,45	13.250	0.875	HDSC1	RD	CR 1175920	
	336,55	22,23				
	13.250	0.875	HDSA2	VD	CR 1175924	
	336,55	22,23				
	13.250	0.875	HDSA2	RD	CR 527709	
	336,55	22,23				
	13.750	1.250	HDSB1	RD	CR 1175952	
349,25	31,75					
12.000 304,80	13.500	0.875	HDSA1	RD	CR 1200920	
	342,90	22,23				
	14.000	0.844	HDSA2	VD	CR 1200962	
	355,60	21,44				
	14.000	1.000	HDSB1	RD	CR 1200958	
	355,60	25,40				
	14.000	1.250	HDSB1	RD	CR 1200952	
355,60	31,75					
12.250 311,15	13.750	0.875	HDSC1	RD	CR 1225928	
	349,25	22,23				
	13.750	1.105	HDSC1	RD	CR 1225920	
	349,25	28,07				
	14.250	1.250	HDSA2	RD	CR 1225588	
	361,95	20,65				
	14.250	1.250	HDSA1	RD	CR 1225960	
361,95	31,75					
12.500 317,50	13.750	0.906	HDSA2	RD	CR 1250912	
	349,25	23,00				
	14.000	0.875	HDSA2	DD	CR 1250272	
	356,60	22,23				
	14.000	0.875	HDSA2	DD	CR 1250922	
	355,60	22,23				
	14.500	1.250	HDSA1	RD	CR 1250950	
368,30	31,75					
12.750 323,85	14.750	1.250	HDSB1	RD	CR 1275950	
	374,65	31,75				
12.875 327,03	14.125	0.875	HDSA2	RD	CR 1287912	
	358,78	22,23				

Dimensions			Design	Lip material	Designation
Shaft	Bore	Nominal seal width			
d_1	D	b	-	-	-
in./mm			-	-	-
13.000 330,20	14.500	0.875	HDSA1	RD	CR 1300900
	368,30	22,23			
	14.500	0.875	HDSB1	RD	CR 1300929
	368,30	22,23			
	14.500	1.000	HDSA1	RD	CR 1300920
368,30	25,40				
13.250 336,55	14.750	0.906	HDSA2	DD	CR 1325922
	374,65	23,00			
	14.750	0.906	HDSA2	VD	CR 1325928
	374,65	23,00			
	14.875	1.000	HDSA2	DD	CR 1325932
13.386 340,00	15.000	1.250	HDSA1	RD	CR 1325940
	377,83	25,40			
	15.000	1.250	HDSA1	RD	CR 1325940
	381,00	31,75			
	15.250	1.000	HDSA1	RD	CR 1325950
387,35	25,40				
13.500 342,90	15.000	0.875	HDSA2	VD	CR 1338273
	381,00	22,23			
13.750 349,25	15.500	0.875	HDSA2	RD	CR 1350954
	393,70	22,23			
	15.500	1.250	HDSB1	RD	CR 1350970
	393,70	31,75			
	15.500	1.250	HDSB1	VD	CR 593517
393,70	31,75				
13.875 352,43	15.500	0.875	HDSA1	VD	CR 1375418
	393,70	22,23			
13.875 352,43	15.125	0.875	HDSA2	RD	CR 1387912
	384,18	22,23			
13.938 354,03	15.744	1.250	HDSA2	RD	CR 1394942
	399,90	31,75			
14.000 355,60	15.500	0.875	HDSC1	RD	CR 1400928
	393,70	22,23			
	15.500	0.985	HDSC1	RD	CR 1400910
	393,70	25,02			
	15.500	1.000	HDSA1	RD	CR 1400925
	393,90	25,40			
	16.000	1.000	HDSA1	VT	CR 1400957
	406,40	25,40			
	16.000	1.375	HDSA1	RD	CR 1400950
	406,40	34,93			
14.250 361,95	16.250	1.000	HDSA2	RD	CR 1400965
	412,75	25,40			
	16.250	1.000	HDSA2	VD	CR 528307
	412,75	25,40			
14.250 361,95	16.750	0.968	HDSB2	RD	CR 1400981
	425,45	24,59			
14.400 365,76	15.750	1.000	HDSA1	RD	CR 1425920
	400,05	25,40			
	16.250	1.000	HDSB1	RD	CR 1425950
412,75	25,40				
14.500 368,30	15.587	0.875	HDSB1	RD	CR 1440901
	395,91	22,23			
14.500 368,30	16.000	0.870	HDSC2	DD	CR 1450922
	406,40	22,10			

Radial shaft seals – HDSA, HDSB and HDSC seals – inch dimensions

d_1 15.000 – 46.840 in.

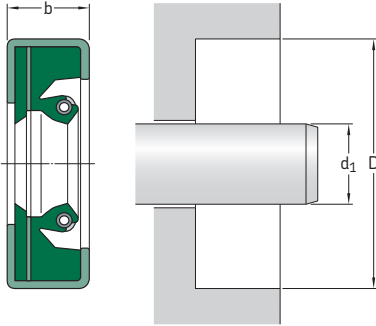

The table includes only a selection of available sizes. Contact your SKF sales representative for more information.

Please see pages 74 to 76 for housing bore requirements.

Dimensions			Design	Lip material	Designation
Shaft	Bore	Nominal seal width			
d_1	D	b	-	-	-
in./mm					
15.000	17.000	0.875	HDSA1	RD	CR 1500951
381,00	431,80	22,23			
	17.000	1.250	HDSA1	RD	CR 1500950
	431,80	31,75			
	17.500	1.000	HDSA1	RD	CR 1500973
	444,50	25,40			
15.125	16.375	0.875	HDSA2	RD	CR 1512912
384,18	415,93	22,23			
15.313	17.313	0.813	HDSA2	RD	CR 592865
388,95	439,75	20,65			
	17.313	0.875	HDSA1	RD	CR 1531950
	439,75	22,23			
15.375	16.625	0.875	HDSA2	RD	CR 1537142
390,53	422,28	22,23			
15.750	17.750	1.250	HDSA1	RD	CR 1575910
400,05	450,85	31,75			
16.000	18.000	0.875	HDSA1	RD	CR 1600951
406,40	457,20	22,23			
	18.000	1.000	HDSA2	RD	CR 1600955
	457,20	25,40			
	18.000	1.125	HDSB1	RD	CR 1600940
	457,20	28,58			
	18.000	1.125	HDSA1	RD	CR 1600941
	457,20	28,58			
16.375	17.562	1.000	HDSA1	RD	CR 1637901
415,93	446,07	25,40			
17.000	18.250	0.875	HDSA2	RD	CR 1700142
431,80	463,55	22,23			
	19.000	1.250	HDSA1	RD	CR 1700950
	482,60	31,75			

Dimensions			Design	Lip material	Designation
Shaft	Bore	Nominal seal width			
d_1	D	b	-	-	-
in./mm					
17.500	19.000	1.250	HDSA1	RD	CR 1750920
444,50	482,60	31,75			
	19.500	1.000	HDSA2	RD	CR 1750958
	495,30	25,40			
	19.500	1.250	HDSA1	RD	CR 1750952
	495,30	31,75			
18.000	20.000	1.500	HDSA1	RD	CR 1800950
457,20	508,00	38,10			
	20.250	1.000	HDSA2	RD	CR 1800965
	514,35	25,40			
	20.250	1.000	HDSA2	VD	CR 528308
	514,35	25,40			
18.500	20.500	0.968	HDSA2	VD	CR 1850952
469,90	520,70	24,59			
19.000	21.000	1.250	HDSC1	RD	CR 1900950
482,60	533,40	31,75			
19.250	20.750	0.875	HDSA1	RD	CR 1925920
488,95	527,05	22,23			
19.500	21.500	1.250	HDSA1	RD	CR 1950950
495,30	546,10	31,75			
19.750	22.125	1.000	HDSA1	RD	CR 1975972
501,65	561,98	25,40			
20.000	21.250	1.375	HDSA1	RD	CR 2000913
508,00	539,75	34,93			
	21.500	0.875	HDSA1	VD	CR 593789
	546,10	22,23			
20.438	22.500	1.000	HDSA1	RD	CR 2044580
519,13	571,50	25,40			
20.500	22.000	1.500	HDSA2	RD	CR 2050282
520,70	558,80	38,10			
	22.500	0.875	HDSA2	VD	CR 2050954
	571,50	22,23			

Dimensions			Design	Lip material	Designation
Shaft	Bore	Nominal seal width			
d_1	D	b			
in./mm			-	-	-
20.750 527,05	22.750 577,85	1.250 31,75	HDSA1	RD	CR 2075950
21.000 533,40	22.250 565,15	1.375 34,93	HDSA1	RD	CR 2100913
	23.000 584,20	0.875 22,23	HDSC2	RD	CR 2100955
21.250 539,75	23.000 584,20	0.875 22,23	HDSA1	RD	CR 2125940
21.500 546,10	23.500 596,90	1.000 25,40	HDSA1	RD	CR 594356
22.000 558,80	23.500 596,90	0.875 22,23	HDSA1	RD	CR 2200920
23.000 584,20	24.500 622,30	0.875 22,23	HDSB1	RD	CR 2300921
24.000 609,60	26.250 666,75	0.875 22,23	HDSA2	RD	CR 2400962
24.250 615,95	26.250 666,75	0.875 22,23	HDSA1	VD	CR 2425950
25.000	27.500 698,50	1.000 25,40	HDSB1	RD	CR 2500971
32.000 812,80	34.000 863,60	0.875 22,23	HDSA2	DD	CR 3200958
45.000 1 143,00	46.627 1 184,33	1.000 25,40	HDSB2	RD	CR 4500930
46.840 1 189,74	48.000 1 219,20	1.188 30,18	HDSA2	RD	CR 4684912

Radial shaft seals – HDSE1 – metric dimensions

d_1 850 mm

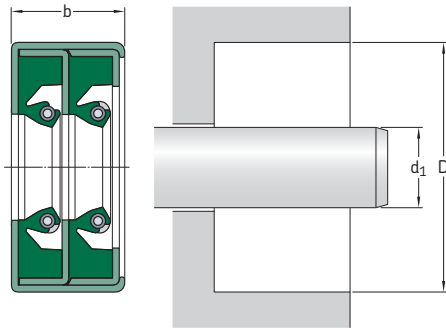

The table includes only a selection of available sizes. Contact your SKF sales representative for more information.

Please see **pages 74 to 76** for housing bore requirements.

Dimensions		Nominal seal width b	Design	Lip material	Designation
Shaft	Bore				
d_1	D				
mm			–	–	–
850	910	50	HDSE1	RR	CR 850×910×50 HDSE1 RR

Radial shaft seals – HDSD and HDSE seals – inch dimensions

d_1 18.000 – 63.130 in.

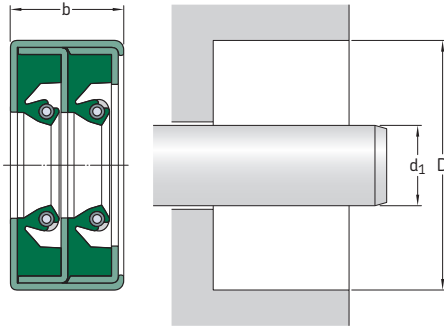

The table includes only a selection of available sizes. Contact your SKF sales representative for more information.

Please see **pages 74 to 76** for housing bore requirements.

Dimensions Shaft	Bore	Nominal seal width b	Design	Lip material	Designation
d_1	D				
in./mm					
18.000	20.000	1.250	HDSD2	RR	CR 1800570
457,20	508,00	31,75			
	20.000	1.500	HDSD1	RR	CR 1800956
	508,00	38,10			
	20.250	1.250	HDSE2	RR	CR 1800966
	514,35	31,75			
18.500	20.000	1.250	HDSD2	RR	CR 1850922
469,90	508,00	31,75			
19.125	21.250	1.750	HDSD1	RR	CR 1913960
485,78	539,75	44,45			
20.000	22.000	1.813	HDSE1	RR	CR 2000951
508,00	558,80	46,05			
21.750	24.750	1.500	HDSD1	RR	CR 2175920
552,45	628,65	38,10			
	24.750	1.500	HDSD2	VV	CR 2175992
	628,65	38,10			
	24.750	1.500	HDSD1	VV	CR 2175997
	628,65	38,10			
	24.750	1.500	HDSE1	VV	CR 2175998
	628,65	38,10			
22.000	24.000	1.250	HDSD1	RR	CR 2200953
558,80	609,60	31,75			
	24.000	1.250	HDSE2	DD	CR 2200958
	609,60	31,75			
	24.000	1.250	HDSD2	DD	CR 2200962
	609,60	31,75			
23.000	24.750	1.250	HDSE1	VV	CR 2300983
584,20	628,65	31,75			
23.500	25.500	1.250	HDSD2	RR	CR 2350955
596,90	647,70	31,75			
25.500	28.500	1.250	HDSD2	RR	CR 2550912
647,70	723,90	31,75			

Dimensions Shaft d_1	Bore D	Nominal seal width b	Design	Lip material	Designation
in./mm			–	–	–
27.000 685,80	29,000 736,60	1.875 47,63	HDSE2	DD	CR 2700953
27.688 703,28	29,812 757,23	1.250 31,75	HDSE2	RR	CR 2769915
28.000 711,20	31,000 787,40	1.250 31,75	HDSD2	DD	CR 2800998
29.000 736,60	31,000 787,40	1.750 44,45	HDSD1	RR	CR 2900954
31.000 787,40	34,000 863,60	1.250 31,75	HDSD2	RR	CR 3100992
33.000 838,20	34,500 876,30	1.250 31,75	HDSD1	RR	CR 3300920
	34,500 876,30	1.250 31,75	HDSE1	RR	CR 3300921
33.500 850,90	35,500 901,70	1.750 44,45	HDSE1	RR	CR 3350950
35.500 901,70	38,000 965,20	1.250 31,75	HDSE2	VV	CR 3550974
36.000 914,40	38,000 965,20	1.500 38,10	HDSE2	RR	CR 3600954
38.000 965,20	40,000 1 016,00	1.313 33,35	HDSE1	RR	CR 3800950
63.130 1 603,50	64,625 1 641,48	1.375 34,93	HDSD1	RD	CR 6313922

Radial shaft seals – SBF – metric dimensions

d_1 175 – 900 mm

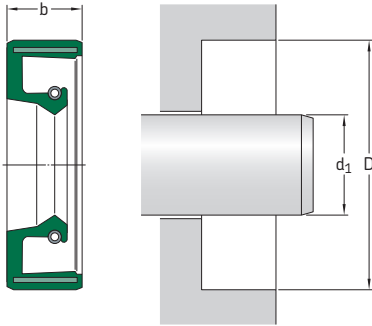

The table includes only a selection of available sizes. Contact your SKF sales representative for more information.

Please see **pages 74 to 76** for housing bore requirements.

Dimensions Shaft	Bore	Nominal seal width b	Designations Lip material R	V
d_1	D			
mm			–	
175	205	15	CR 175×205×15 SBF R	CR 175×205×15 SBF V
230	260	15	CR 230×260×15 SBF R	CR 230×260×15 SBF V
240	270 280	15 16	CR 240×270×15 SBF R CR 240×280×16 SBF R	CR 240×270×15 SBF V CR 240×280×16 SBF V
245	275	16	CR 245×275×16 SBF R	CR 245×275×16 SBF V
260	290 310	16 16	CR 260×290×16 SBF R CR 260×310×16 SBF R	CR 260×290×16 SBF V CR 260×310×16 SBF V
270	235	16	CR 270×235×16 SBF R	CR 270×235×16 SBF V
290	330 334	18 20	CR 290×330×18 SBF R CR 290×334×20 SBF R	CR 290×330×18 SBF V CR 290×334×20 SBF V
300	344	20	CR 300×344×20 SBF R	CR 300×344×20 SBF V
316	360	20	CR 316×360×20 SBF R	CR 316×360×20 SBF V
325	365	16	CR 325×365×16 SBF R	CR 325×365×16 SBF V
340	380	20	CR 340×380×20 SBF R	CR 340×380×20 SBF V
360	400	20	CR 360×400×20 SBF R	CR 360×400×20 SBF V
385	430	25	CR 385×430×25 SBF R	CR 385×430×25 SBF V
390	430	20	CR 390×430×20 SBF R	CR 390×430×20 SBF V
400	440	20	CR 400×440×20 SBF R	CR 400×440×20 SBF V
430	480	22	CR 430×480×22 SBF R	CR 430×480×22 SBF V
440	490	25	CR 440×490×25 SBF R	CR 440×490×25 SBF V
450	500	25	CR 450×500×25 SBF R	CR 450×500×25 SBF V
900	960	27	CR 900×960×27 SBF R	CR 900×960×27 SBF V

Radial shaft seals – SBF – inch dimensions

d_1 11.000 – 27.500 in.

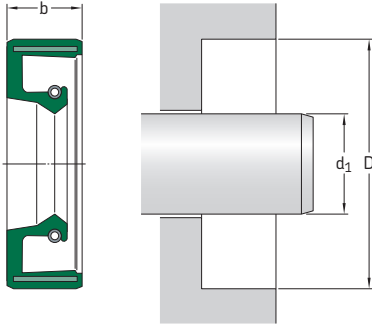

The table includes only a selection of available sizes. Contact your SKF sales representative for more information.

Please see **pages 74 to 76** for housing bore requirements.

Dimensions		Nominal seal width b	Designations Lip material R	V
Shaft d_1	Bore D			
in./mm			–	
11.000 279,40	12.500 317,50	0.625 15,88	CR SBF 5809 R	CR SBF 5809 V
20.500 520,70	22.500 571,50	0.875 22,23	CR SBF 7083 R	CR SBF 7083 V
21.500 546,10	23.469 596,10	0.875 22,23	CR SBF 7175 R	CR SBF 7175 V
23.000 584,20	24.500 622,30	0.750 19,05	CR SBF 7270 R	CR SBF 7270 V
27.500 698,50	29.500 749,30	1.000 25,40	CR SBF 7406 R	CR SBF 7406 V

Radial shaft seals – HSF1 (split) and HSF5 (solid) – metric dimensions

d_1 40 – 215 mm

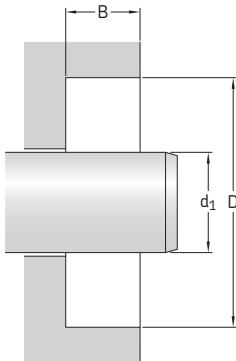

The table includes only a selection of available sizes. Contact your SKF sales representative for more information.

Please see **pages 74 to 76** for housing bore requirements.

Dimensions		Bore depth B	Designations	
Shaft diameter d_1	Bore diameter D		Split version (HSF1) Lip material R, V	Solid version (HSF5) Lip material R, V
mm				
40	60	10	CR 40×60×10 HSF1 R	CR 40×60×10 HSF5 R
			CR 40×60×10 HSF1 V	CR 40×60×10 HSF5 V
55	80	12,20	CR 55×80×12 HSF1 R	CR 55×80×12 HSF5 R
			CR 55×80×12 HSF1 V	CR 55×80×12 HSF5 V
60	80	10	CR 60×80×10 HSF1 R CR 60×80×10 HSF1 V	CR 60×80×10 HSF5 R CR 60×80×10 HSF5 V
70	102	12,50	CR 70×102×13 HSF1 R CR 70×102×13 HSF1 V	CR 70×102×13 HSF5 R CR 70×102×13 HSF5 V
80	100	8	CR 80×100×8 HSF1 R CR 80×100×8 HSF1 V	CR 80×100×8 HSF5 R CR 80×100×8 HSF5 V
	112	12,50	CR 80×112×13 HSF1 R CR 80×112×13 HSF1 V	CR 80×112×13 HSF5 R CR 80×112×13 HSF5 V
84	100	8	CR 84×100×8 HSF1 R CR 84×100×8 HSF1 V	CR 84×100×8 HSF5 R CR 84×100×8 HSF5 V
85	101	8	CR 85×101×8 HSF1 R CR 85×101×8 HSF1 V	CR 85×101×8 HSF5 R CR 85×101×8 HSF5 V
	120	12	CR 85×120×12 HSF1 R CR 85×120×12 HSF1 V	CR 85×120×12 HSF5 R CR 85×120×12 HSF5 V
90	110	12	CR 90×110×12 HSF1 R CR 90×110×12 HSF1 V	CR 90×110×12 HSF5 R CR 90×110×12 HSF5 V
100	116	8	CR 100×116×8 HSF1 R CR 100×116×8 HSF1 V	CR 100×116×8 HSF5 R CR 100×116×8 HSF5 V
	130	10	CR 100×130×10 HSF1 R CR 100×130×10 HSF1 V	CR 100×130×10 HSF5 R CR 100×130×10 HSF5 V
110	130	12	CR 110×130×12 HSF1 R CR 110×130×12 HSF1 V	CR 110×130×12 HSF5 R CR 110×130×12 HSF5 V
120	150	13	CR 120×150×13 HSF1 R CR 120×150×13 HSF1 V	CR 120×150×13 HSF5 R CR 120×150×13 HSF5 V

Dimensions Shaft diameter d ₁	Bore diameter D	Bore depth B	Designations	
			Split version (HSF1) Lip material R, V	Solid version (HSF5) Lip material R, V
mm			-	
125	155	12,50	CR 125×155×13 HSF1 R	CR 125×155×13 HSF5 R
	160	12	CR 125×155×13 HSF1 V CR 125×160×12 HSF1 R CR 125×160×12 HSF1 V	CR 125×155×13 HSF5 V CR 125×160×12 HSF5 R CR 125×160×12 HSF5 V
127	165	16	CR 127×165×16 HSF1 R CR 127×165×16 HSF1 V	CR 127×165×16 HSF5 R CR 127×165×16 HSF5 V
135	160	12	CR 135×160×12 HSF1 R CR 135×160×12 HSF1 V	CR 135×160×12 HSF5 R CR 135×160×12 HSF5 V
140	170	12	CR 140×170×12 HSF1 R CR 140×170×12 HSF1 V	CR 140×170×12 HSF5 R CR 140×170×12 HSF5 V
145	180	14	CR 145×180×14 HSF1 R CR 145×180×14 HSF1 V	CR 145×180×14 HSF5 R CR 145×180×14 HSF5 V
150	180	12	CR 150×180×12 HSF1 R CR 150×180×12 HSF1 V	CR 150×180×12 HSF5 R CR 150×180×12 HSF5 V
160	190	15	CR 160×190×15 HSF1 R CR 160×190×15 HSF1 V	CR 160×190×15 HSF5 R CR 160×190×15 HSF5 V
	200	10	CR 160×200×10 HSF1 R CR 160×200×10 HSF1 V	CR 160×200×10 HSF5 R CR 160×200×10 HSF5 V
170	200	12	CR 170×200×12 HSF1 R CR 170×200×12 HSF1 V	CR 170×200×12 HSF5 R CR 170×200×12 HSF5 V
	200	16	CR 170×200×16 HSF1 R CR 170×200×16 HSF1 V	CR 170×200×16 HSF5 R CR 170×200×16 HSF5 V
	211	16	CR 170×211×16 HSF1 R CR 170×211×16 HSF1 V	CR 170×211×16 HSF5 R CR 170×211×16 HSF5 V
175	200	15	CR 175×200×15 HSF1 R CR 175×200×15 HSF1 V	CR 175×200×15 HSF5 R CR 175×200×15 HSF5 V
180	200	15	CR 180×200×15 HSF1 R CR 180×200×15 HSF1 V	CR 180×200×15 HSF5 R CR 180×200×15 HSF5 V
	222	16	CR 180×222×16 HSF1 R CR 180×222×16 HSF1 V	CR 180×222×16 HSF5 R CR 180×222×16 HSF5 V
185	225	16	CR 185×225×16 HSF1 R CR 185×225×16 HSF1 V	CR 185×225×16 HSF5 R CR 185×225×16 HSF5 V
190	220	15	CR 190×220×15 HSF1 R CR 190×220×15 HSF1 V	CR 190×220×15 HSF5 R CR 190×220×15 HSF5 V
	225	18	CR 190×225×18 HSF1 R CR 190×225×18 HSF1 V	CR 190×225×18 HSF5 R CR 190×225×18 HSF5 V
	230	16	CR 190×230×16 HSF1 R CR 190×230×16 HSF1 V	CR 190×230×16 HSF5 R CR 190×230×16 HSF5 V
200	240	16	CR 200×240×16 HSF1 R CR 200×240×16 HSF1 V	CR 200×240×16 HSF5 R CR 200×240×16 HSF5 V
	250	18	CR 200×250×18 HSF1 R CR 200×250×18 HSF1 V	CR 200×250×18 HSF5 R CR 200×250×18 HSF5 V
210	240	12	CR 210×240×12 HSF1 R CR 210×240×12 HSF1 V	CR 210×240×12 HSF5 R CR 210×240×12 HSF5 V
	250	16	CR 210×250×16 HSF1 R CR 210×250×16 HSF1 V	CR 210×250×16 HSF5 R CR 210×250×16 HSF5 V
215	248	15	CR 215×248×15 HSF1 R CR 215×248×15 HSF1 V	CR 215×248×15 HSF5 R CR 215×248×15 HSF5 V
	250	16	CR 215×250×16 HSF1 R CR 215×250×16 HSF1 V	CR 215×250×16 HSF5 R CR 215×250×16 HSF5 V

Radial shaft seals – HSF1 (split) and HSF5 (solid) – metric dimensions

d₁ 220 – 335 mm

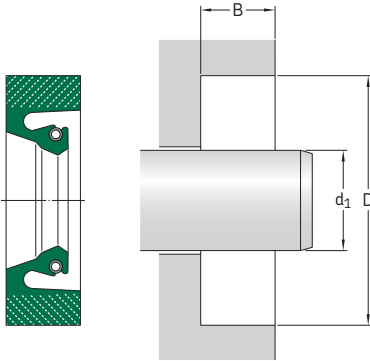

The table includes only a selection of available sizes. Contact your SKF sales representative for more information.

Please see **pages 74 to 76** for housing bore requirements.

Dimensions Shaft diameter d ₁	Bore diameter D	Bore depth B	Designations	
			Split version (HSF1) Lip material R, V	Solid version (HSF5) Lip material R, V
mm			–	
220	180	16	CR 220×180×16 HSF1 R CR 220×180×16 HSF1 V	CR 220×180×16 HSF5 R CR 220×180×16 HSF5 V
	260	16	CR 220×260×16 HSF1 R CR 220×260×16 HSF1 V	CR 220×260×16 HSF5 R CR 220×260×16 HSF5 V
226	276	22,22	CR 226×276×22 HSF1 R CR 226×276×22 HSF1 V	CR 226×276×22 HSF5 R CR 226×276×22 HSF5 V
230	260	15	CR 230×260×15 HSF1 R CR 230×260×15 HSF1 V	CR 230×260×15 HSF5 R CR 230×260×15 HSF5 V
	270	16	CR 230×270×16 HSF1 R CR 230×270×16 HSF1 V	CR 230×270×16 HSF5 R CR 230×270×16 HSF5 V
235	265	15	CR 235×265×15 HSF1 R CR 235×265×15 HSF1 V	CR 235×265×15 HSF5 R CR 235×265×15 HSF5 V
	275	20	CR 235×275×20 HSF1 R CR 235×275×20 HSF1 V	CR 235×275×20 HSF5 R CR 235×275×20 HSF5 V
236	276	16	CR 236×276×16 HSF1 R CR 236×276×16 HSF1 V	CR 236×276×16 HSF5 R CR 236×276×16 HSF5 V
240	275	18	CR 240×275×18 HSF1 R CR 240×275×18 HSF1 V	CR 240×275×18 HSF5 R CR 240×275×18 HSF5 V
			280	18
	290	25		
250	280	15	CR 250×280×15 HSF1 R CR 250×280×15 HSF1 V	CR 250×280×15 HSF5 R CR 250×280×15 HSF5 V
	290	16,50	CR 250×290×17 HSF1 R CR 250×290×17 HSF1 V	CR 250×290×17 HSF5 R CR 250×290×17 HSF5 V
260	290	16	CR 260×290×16 HSF1 R CR 260×290×16 HSF1 V	CR 260×290×16 HSF5 R CR 260×290×16 HSF5 V
	304	20	CR 260×304×20 HSF1 R CR 260×304×20 HSF1 V	CR 260×304×20 HSF5 R CR 260×304×20 HSF5 V
270	310	15	CR 270×310×15 HSF1 R CR 270×310×15 HSF1 V	CR 270×310×15 HSF5 R CR 270×310×15 HSF5 V
	314	20	CR 270×314×20 HSF1 R CR 270×314×20 HSF1 V	CR 270×314×20 HSF5 R CR 270×314×20 HSF5 V

Dimensions Shaft diameter d_1	Bore diameter D	Bore depth B	Designations	
			Split version (HSF1) Lip material R, V	Solid version (HSF5) Lip material R, V
mm			-	
275	315	20	CR 275x315x20 HSF1 R CR 275x315x20 HSF1 V	CR 275x315x20 HSF5 R CR 275x315x20 HSF5 V
280	320	16	CR 280x320x16 HSF1 R CR 280x320x16 HSF1 V	CR 280x320x16 HSF5 R CR 280x320x16 HSF5 V
	320	20	CR 280x320x20 HSF1 R CR 280x320x20 HSF1 V	CR 280x320x20 HSF5 R CR 280x320x20 HSF5 V
	324	20	CR 280x324x20 HSF1 R CR 280x324x20 HSF1 V	CR 280x324x20 HSF5 R CR 280x324x20 HSF5 V
285	310	15	CR 285x310x15 HSF1 R CR 285x310x15 HSF1 V	CR 285x310x15 HSF5 R CR 285x310x15 HSF5 V
289	327	19	CR 289x327x19 HSF1 R CR 289x327x19 HSF1 V	CR 289x327x19 HSF5 R CR 289x327x19 HSF5 V
290	330	20	CR 290x330x20 HSF1 R CR 290x330x20 HSF1 V	CR 290x330x20 HSF5 R CR 290x330x20 HSF5 V
	334	20	CR 290x334x20 HSF1 R CR 290x334x20 HSF1 V	CR 290x334x20 HSF5 R CR 290x334x20 HSF5 V
292	330	15,87	CR 292x330x16 HSF1 R CR 292x330x16 HSF1 V	CR 292x330x16 HSF5 R CR 292x330x16 HSF5 V
300	340	16,50	CR 300x340x17 HSF1 R CR 300x340x17 HSF1 V	CR 300x340x17 HSF5 R CR 300x340x17 HSF5 V
	340	20	CR 300x340x20 HSF1 R CR 300x340x20 HSF1 V	CR 300x340x20 HSF5 R CR 300x340x20 HSF5 V
304	348	20	CR 304x348x20 HSF1 R CR 304x348x20 HSF1 V	CR 304x348x20 HSF5 R CR 304x348x20 HSF5 V
308	352	20	CR 308x352x20 HSF1 R CR 308x352x20 HSF1 V	CR 308x352x20 HSF5 R CR 308x352x20 HSF5 V
310	345	18	CR 310x345x18 HSF1 R CR 310x345x18 HSF1 V	CR 310x345x18 HSF5 R CR 310x345x18 HSF5 V
	354	20,50	CR 310x354x21 HSF1 R CR 310x354x21 HSF1 V	CR 310x354x21 HSF5 R CR 310x354x21 HSF5 V
311	345	18,30	CR 311x345x18 HSF1 R CR 311x345x18 HSF1 V	CR 311x345x18 HSF5 R CR 311x345x18 HSF5 V
314	355	20	CR 314x355x20 HSF1 R CR 314x355x20 HSF1 V	CR 314x355x20 HSF5 R CR 314x355x20 HSF5 V
316	360	20	CR 316x360x20 HSF1 R CR 316x360x20 HSF1 V	CR 316x360x20 HSF5 R CR 316x360x20 HSF5 V
320	350	15	CR 320x350x15 HSF1 R CR 320x350x15 HSF1 V	CR 320x350x15 HSF5 R CR 320x350x15 HSF5 V
	360	18	CR 320x360x18 HSF1 R CR 320x360x18 HSF1 V	CR 320x360x18 HSF5 R CR 320x360x18 HSF5 V
328	372	20,20	CR 328x372x20 HSF1 R CR 328x372x20 HSF1 V	CR 328x372x20 HSF5 R CR 328x372x20 HSF5 V
330	370	18	CR 330x370x18 HSF1 R CR 330x370x18 HSF1 V	CR 330x370x18 HSF5 R CR 330x370x18 HSF5 V
	374	20	CR 330x374x20 HSF1 R CR 330x374x20 HSF1 V	CR 330x374x20 HSF5 R CR 330x374x20 HSF5 V
335	373	19	CR 335x373x19 HSF1 R CR 335x373x19 HSF1 V	CR 335x373x19 HSF5 R CR 335x373x19 HSF5 V

Radial shaft seals – HSF1 (split) and HSF5 (solid) – metric dimensions

d_1 340 – 530 mm

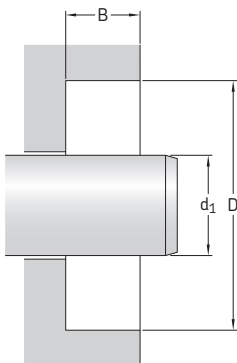

The table includes only a selection of available sizes. Contact your SKF sales representative for more information.

Please see **pages 74 to 76** for housing bore requirements.

Dimensions		Bore depth B	Designations	
Shaft diameter d_1	Bore diameter D		Split version (HSF1) Lip material R, V	Solid version (HSF5) Lip material R, V
mm				
340	380	16	CR340×380×16 HSF1 R CR 340×380×16 HSF1 V	CR 340×380×16 HSF5 R CR 340×380×16 HSF5 V
	380	20	CR 340×380×20 HSF1 R CR 340×380×20 HSF1 V	CR 340×380×20 HSF5 R CR 340×380×20 HSF5 V
350	380	17,70	CR 350×380×18 HSF1 R CR 350×380×18 HSF1 V	CR 350×380×18 HSF5 R CR 350×380×18 HSF5 V
	394	20	CR 350×394×20 HSF1 R CR 350×394×20 HSF1 V	CR 350×394×20 HSF5 R CR 350×394×20 HSF5 V
360	404	20	CR 360×404×20 HSF1 R CR 360×404×20 HSF1 V	CR 360×404×20 HSF5 R CR 360×404×20 HSF5 V
	410	20	CR 360×410×20 HSF1 R CR 360×410×20 HSF1 V	CR 360×410×20 HSF5 R CR 360×410×20 HSF5 V
362	400	20	CR 362×400×20 HSF1 R CR 362×400×20 HSF1 V	CR 362×400×20 HSF5 R CR 362×400×20 HSF5 V
	406	22	CR 362×406×22 HSF1 R CR 362×406×22 HSF1 V	CR 362×406×22 HSF5 R CR 362×406×22 HSF5 V
370	410	20	CR 370×410×20 HSF1 R CR 370×410×20 HSF1 V	CR 370×410×20 HSF5 R CR 370×410×20 HSF5 V
	414	20	CR 370×414×20 HSF1 R CR 370×414×20 HSF1 V	CR 370×414×20 HSF5 R CR 370×414×20 HSF5 V
380	420	20	CR 380×420×20 HSF1 R CR 380×420×20 HSF1 V	CR 380×420×20 HSF5 R CR 380×420×20 HSF5 V
	387	431	22,50	CR 387×431×23 HSF1 R CR 387×431×23 HSF1 V
438		25,40	CR 387×438×25 HSF1 R CR 387×438×25 HSF1 V	CR 387×438×25 HSF5 R CR 387×438×25 HSF5 V
390	430	20	CR 390×430×20 HSF1 R CR 390×430×20 HSF1 V	CR 390×430×20 HSF5 R CR 390×430×20 HSF5 V
	395	439	20	CR 395×439×20 HSF1 R CR 395×439×20 HSF1 V
439		20,50	CR 395×439×21 HSF1 R CR 395×439×21 HSF1 V	CR 395×439×21 HSF5 R CR 395×439×21 HSF5 V

Dimensions Shaft diameter d_1	Bore diameter D	Bore depth B	Designations	Solid version (HSF5)
			Split version (HSF1) Lip material R, V	Lip material R, V
mm			–	
400	440	20	CR 400x440x20 HSF1 R	CR 400x440x20 HSF5 R
	450	22	CR 400x440x20 HSF1 V CR 400x450x22 HSF1 R CR 400x450x22 HSF1 V	CR 400x440x20 HSF5 V CR 400x450x22 HSF5 R CR 400x450x22 HSF5 V
420	460	20	CR 420x460x20 HSF1 R	CR 420x460x20 HSF5 R
	470	25	CR 420x460x20 HSF1 V CR 420x470x25 HSF1 R CR 420x470x25 HSF1 V	CR 420x460x20 HSF5 V CR 420x470x25 HSF5 R CR 420x470x25 HSF5 V
430	480	25	CR 430x480x25 HSF1 R	CR 430x480x25 HSF5 R
			CR 430x480x25 HSF1 V	CR 430x480x25 HSF5 V
435	485	22	CR 435x485x22 HSF1 R	CR 435x485x22 HSF5 R
			CR 435x485x22 HSF1 V	CR 435x485x22 HSF5 V
438	476	24	CR 438x476x24 HSF1 R	CR 438x476x24 HSF5 R
			CR 438x476x24 HSF1 V	CR 438x476x24 HSF5 V
440	480	20	CR 440x480x20 HSF1 R	CR 440x480x20 HSF5 R
	490	20	CR 440x480x20 HSF1 V CR 440x490x20 HSF1 R CR 440x490x20 HSF1 V	CR 440x480x20 HSF5 V CR 440x490x20 HSF5 R CR 440x490x20 HSF5 V
446	486	16,50	CR 446x486x17 HSF1 R	CR 446x486x17 HSF5 R
			CR 446x486x17 HSF1 V	CR 446x486x17 HSF5 V
450	490	18	CR 450x490x18 HSF1 R	CR 450x490x18 HSF5 R
	500	22	CR 450x490x18 HSF1 V CR 450x500x22 HSF1 R CR 450x500x22 HSF1 V	CR 450x490x18 HSF5 V CR 450x500x22 HSF5 R CR 450x500x22 HSF5 V
460	510	22	CR 460x510x22 HSF1 R	CR 460x510x22 HSF5 R
	510	25	CR 460x510x22 HSF1 V CR 460x510x25 HSF1 R CR 460x510x25 HSF1 V	CR 460x510x22 HSF5 V CR 460x510x25 HSF5 R CR 460x510x25 HSF5 V
470	520	25	CR 470x520x25 HSF1 R	CR 470x520x25 HSF5 R
			CR 470x520x25 HSF1 V	CR 470x520x25 HSF5 V
480	520	18	CR 480x520x18 HSF1 R	CR 480x520x18 HSF5 R
			CR 480x520x18 HSF1 V	CR 480x520x18 HSF5 V
	530	22	CR 480x530x22 HSF1 R	CR 480x530x22 HSF5 R
	550	25	CR 480x530x22 HSF1 V CR 480x550x25 HSF1 R CR 480x550x25 HSF1 V	CR 480x530x22 HSF5 V CR 480x550x25 HSF5 R CR 480x550x25 HSF5 V
495	545	22	CR 495x545x22 HSF1 R	CR 495x545x22 HSF5 R
			CR 495x545x22 HSF1 V	CR 495x545x22 HSF5 V
500	540	10	CR 500x540x10 HSF1 R	CR 500x540x10 HSF5 R
	550	20	CR 500x540x10 HSF1 V CR 500x550x20 HSF1 R CR 500x550x20 HSF1 V	CR 500x540x10 HSF5 V CR 500x550x20 HSF5 R CR 500x550x20 HSF5 V
520	560	18	CR 520x560x18 HSF1 R	CR 520x560x18 HSF5 R
	560	20	CR 520x560x18 HSF1 V CR 520x560x20 HSF1 R CR 520x560x20 HSF1 V	CR 520x560x18 HSF5 V CR 520x560x20 HSF5 R CR 520x560x20 HSF5 V
525	575	22	CR 525x575x22 HSF1 R	CR 525x575x22 HSF5 R
			CR 525x575x22 HSF1 V	CR 525x575x22 HSF5 V
530	580	22	CR 530x580x22 HSF1 R	CR 530x580x22 HSF5 R
	580	25	CR 530x580x22 HSF1 V CR 530x580x25 HSF1 R CR 530x580x25 HSF1 V	CR 530x580x22 HSF5 V CR 530x580x25 HSF5 R CR 530x580x25 HSF5 V

Radial shaft seals – HSF1 (split) and HSF5 (solid) – metric dimensions

d₁ 535 – 840 mm

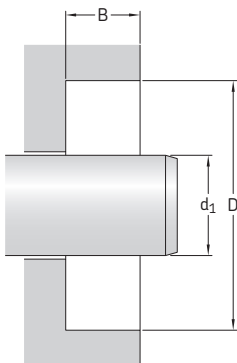

The table includes only a selection of available sizes. Contact your SKF sales representative for more information.

Please see **pages 74 to 76** for housing bore requirements.

Dimensions Shaft diameter d ₁	Bore diameter D	Bore depth B	Designations	
			Split version (HSF1) Lip material R, V	Solid version (HSF5) Lip material R, V
mm			–	
535	585	22	CR 535×585×22 HSF1 R CR 535×585×22 HSF1 V	CR 535×585×22 HSF5 R CR 535×585×22 HSF5 V
540	590	22	CR 540×590×22 HSF1 R CR 540×590×22 HSF1 V	CR 540×590×22 HSF5 R CR 540×590×22 HSF5 V
	590	30	CR 540×590×30 HSF1 R CR 540×590×30 HSF1 V	CR 540×590×30 HSF5 R CR 540×590×30 HSF5 V
550	600	22,30	CR 550×600×22 HSF1 R CR 550×600×22 HSF1 V	CR 550×600×22 HSF5 R CR 550×600×22 HSF5 V
560	604	20	CR 560×604×20 HSF1 R CR 560×604×20 HSF1 V	CR 560×604×20 HSF5 R CR 560×604×20 HSF5 V
	610	22,30	CR 560×610×22 HSF1 R CR 560×610×22 HSF1 V	CR 560×610×22 HSF5 R CR 560×610×22 HSF5 V
570	616	19	CR 570×616×19 HSF1 R CR 570×616×19 HSF1 V	CR 570×616×19 HSF5 R CR 570×616×19 HSF5 V
	620	25	CR 570×620×25 HSF1 R CR 570×620×25 HSF1 V	CR 570×620×25 HSF5 R CR 570×620×25 HSF5 V
575	625	22	CR 575×625×22 HSF1 R CR 575×625×22 HSF1 V	CR 575×625×22 HSF5 R CR 575×625×22 HSF5 V
580	630	22	CR 580×630×22 HSF1 R CR 580×630×22 HSF1 V	CR 580×630×22 HSF5 R CR 580×630×22 HSF5 V
600	650	22	CR 600×650×22 HSF1 R CR 600×650×22 HSF1 V	CR 600×650×22 HSF5 R CR 600×650×22 HSF5 V
620	670	22	CR 620×670×22 HSF1 R CR 620×670×22 HSF1 V	CR 620×670×22 HSF5 R CR 620×670×22 HSF5 V
	684	25	CR 620×684×25 HSF1 R CR 620×684×25 HSF1 V	CR 620×684×25 HSF5 R CR 620×684×25 HSF5 V
625	689	25	CR 625×689×25 HSF1 R CR 625×689×25 HSF1 V	CR 625×689×25 HSF5 R CR 625×689×25 HSF5 V
630	690	30	CR 630×690×30 HSF1 R CR 630×690×30 HSF1 V	CR 630×690×30 HSF5 R CR 630×690×30 HSF5 V

Dimensions Shaft diameter d_1	Bore diameter D	Bore depth B	Designations	
			Split version (HSF1) Lip material R, V	Solid version (HSF5) Lip material R, V
mm			–	
635	705	30	CR 635×705×30 HSF1 R CR 635×705×30 HSF1 V	CR 635×705×30 HSF5 R CR 635×705×30 HSF5 V
650	690	18	CR 650×690×18 HSF1 R CR 650×690×18 HSF1 V	CR 650×690×18 HSF5 R CR 650×690×18 HSF5 V
660	724	25	CR 660×724×25 HSF1 R CR 660×724×25 HSF1 V	CR 660×724×25 HSF5 R CR 660×724×25 HSF5 V
670	734	25	CR 670×734×25 HSF1 R CR 670×734×25 HSF1 V	CR 670×734×25 HSF5 R CR 670×734×25 HSF5 V
685	749	25	CR 685×749×25 HSF1 R CR 685×749×25 HSF1 V	CR 685×749×25 HSF5 R CR 685×749×25 HSF5 V
700	760	30	CR 700×760×30 HSF1 R CR 700×760×30 HSF1 V	CR 700×760×30 HSF5 R CR 700×760×30 HSF5 V
710	770	30	CR 710×770×30 HSF1 R CR 710×770×30 HSF1 V	CR 710×770×30 HSF5 R CR 710×770×30 HSF5 V
	774	25	CR 710×774×25 HSF1 R CR 710×774×25 HSF1 V	CR 710×774×25 HSF5 R CR 710×774×25 HSF5 V
730	794	25	CR 730×794×25 HSF1 R CR 730×794×25 HSF1 V	CR 730×794×25 HSF5 R CR 730×794×25 HSF5 V
736	800	25	CR 736×800×25 HSF1 R CR 736×800×25 HSF1 V	CR 736×800×25 HSF5 R CR 736×800×25 HSF5 V
740	785	18	CR 740×785×18 HSF1 R CR 740×785×18 HSF1 V	CR 740×785×18 HSF5 R CR 740×785×18 HSF5 V
744	808	25	CR 744×808×25 HSF1 R CR 744×808×25 HSF1 V	CR 744×808×25 HSF5 R CR 744×808×25 HSF5 V
750	810	30	CR 750×810×30 HSF1 R CR 750×810×30 HSF1 V	CR 750×810×30 HSF5 R CR 750×810×30 HSF5 V
	814	25	CR 750×814×25 HSF1 R CR 750×814×25 HSF1 V	CR 750×814×25 HSF5 R CR 750×814×25 HSF5 V
760	820	30	CR 760×820×30 HSF1 R CR 760×820×30 HSF1 V	CR 760×820×30 HSF5 R CR 760×820×30 HSF5 V
770	834	25	CR 770×834×25 HSF1 R CR 770×834×25 HSF1 V	CR 770×834×25 HSF5 R CR 770×834×25 HSF5 V
780	844	25	CR 780×844×25 HSF1 R CR 780×844×25 HSF1 V	CR 780×844×25 HSF5 R CR 780×844×25 HSF5 V
790	850	30	CR 790×850×30 HSF1 R CR 790×850×30 HSF1 V	CR 790×850×30 HSF5 R CR 790×850×30 HSF5 V
800	860	30	CR 800×860×30 HSF1 R CR 800×860×30 HSF1 V	CR 800×860×30 HSF5 R CR 800×860×30 HSF5 V
	865	25	CR 800×865×25 HSF1 R CR 800×865×25 HSF1 V	CR 800×865×25 HSF5 R CR 800×865×25 HSF5 V
810	860	25	CR 810×860×25 HSF1 R CR 810×860×25 HSF1 V	CR 810×860×25 HSF5 R CR 810×860×25 HSF5 V
	874	22	CR 810×874×22 HSF1 R CR 810×874×22 HSF1 V	CR 810×874×22 HSF5 R CR 810×874×22 HSF5 V
840	904	25	CR 840×904×25 HSF1 R CR 840×904×25 HSF1 V	CR 840×904×25 HSF5 R CR 840×904×25 HSF5 V

Radial shaft seals – HSF1 (split) and HSF5 (solid) – metric dimensions

d_1 850 – 1 110 mm

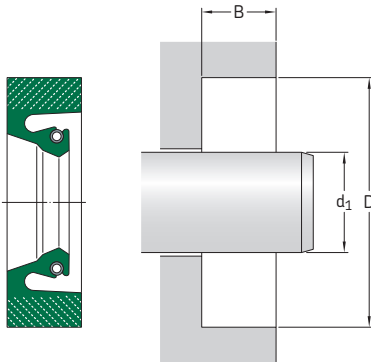

The table includes only a selection of available sizes. Contact your SKF sales representative for more information.

Please see **pages 74 to 76** for housing bore requirements.

Dimensions Shaft diameter d_1	Bore diameter D	Bore depth B	Designations	Solid version (HSF5)
			Split version (HSF1) Lip material R, V	Lip material R, V
mm			–	
850	900	22	CR 850×900×22 HSF1 R CR 850×900×22 HSF1 V	CR 850×900×22 HSF5 R CR 850×900×22 HSF5 V
	904	25	CR 850×904×25 HSF1 R CR 850×904×25 HSF1 V	CR 850×904×25 HSF5 R CR 850×904×25 HSF5 V
	910	30	CR 850×910×30 HSF1 R CR 850×910×30 HSF1 V	CR 850×910×30 HSF5 R CR 850×910×30 HSF5 V
900	960	30	CR 900×960×30 HSF1 R CR 900×960×30 HSF1 V	CR 900×960×30 HSF5 R CR 900×960×30 HSF5 V
	964	32	CR 900×964×32 HSF1 R CR 900×964×32 HSF1 V	CR 900×964×32 HSF5 R CR 900×964×32 HSF5 V
910	974	25	CR 910×974×25 HSF1 R CR 910×974×25 HSF1 V	CR 910×974×25 HSF5 R CR 910×974×25 HSF5 V
	974	25,40	CR 910×974×25 HSF1 R CR 910×974×25 HSF1 V	CR 910×974×25 HSF5 R CR 910×974×25 HSF5 V
920	984	25	CR 920×984×25 HSF1 R CR 920×984×25 HSF1 V	CR 920×984×25 HSF5 R CR 920×984×25 HSF5 V
950	1 000	25	CR 950×1000×25 HSF1 R CR 950×1000×25 HSF1 V	CR 950×1000×25 HSF5 R CR 950×1000×25 HSF5 V
	1 010	30	CR 950×1010×30 HSF1 R CR 950×1010×30 HSF1 V	CR 950×1010×30 HSF5 R CR 950×1010×30 HSF5 V
960	1 024	25	CR 960×1024×25 HSF1 R CR 960×1024×25 HSF1 V	CR 960×1024×25 HSF5 R CR 960×1024×25 HSF5 V
970	1 020	25	CR 970×1020×25 HSF1 R CR 970×1020×25 HSF1 V	CR 970×1020×25 HSF5 R CR 970×1020×25 HSF5 V
	1 034	25	CR 970×1034×25 HSF1 R CR 970×1034×25 HSF1 V	CR 970×1034×25 HSF5 R CR 970×1034×25 HSF5 V
1 000	1 064	25	CR 1000×1064×25 HSF1 R CR 1000×1064×25 HSF1 V	CR 1000×1064×25 HSF5 R CR 1000×1064×25 HSF5 V
1 016	1 043,10	13,70	CR 1016×1043×14 HSF1 R CR 1016×1043×14 HSF1 V	CR 1016×1043×14 HSF5 R CR 1016×1043×14 HSF5 V
1 110	1 174	25	CR 1110×1174×25 HSF1 R CR 1110×1174×25 HSF1 V	CR 1110×1174×25 HSF5 R CR 1110×1174×25 HSF5 V

Radial shaft seals – HSF1 (split) and HSF5 (solid) – inch dimensions

d_1 1.000 – 5.874 in.

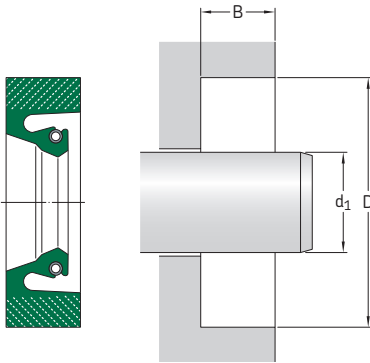

The table includes only a selection of available sizes. Contact your SKF sales representative for more information.

2.20

Please see pages 74 to 76 for housing bore requirements.

Dimensions		Designations				
Shaft diameter d_1	Bore diameter D	Bore depth B	Split version (HSF1) Lip material R	V	Solid version (HSF5) Lip material R	V
in./mm			–			
1.000 25,40	1.874 47,60	0.375 9,53	CR HSF1 5001 R	CR HSF1 5001 V	CR HSF5 5001 R	CR HSF5 5001 V
2.750 69,85	3.375 85,73	0.313 7,95	CR HSF1 5156 R	CR HSF1 5156 V	CR HSF5 5156 R	CR HSF5 5156 V
3.248 82,50	4.500 114,30	0.500 12,70	CR HSF1 5225 R	CR HSF1 5225 V	CR HSF5 5225 R	CR HSF5 5225 V
3.500 88,90	4.500 114,30	0.500 12,70	CR HSF1 5252 R	CR HSF1 5252 V	CR HSF5 5252 R	CR HSF5 5252 V
3.874 98,40	4.878 123,90	0.500 12,70	CR HSF1 5265 R	CR HSF1 5265 V	CR HSF5 5265 R	CR HSF5 5265 V
4.000 101,60	5.000 127,00	0.500 12,70	CR HSF1 5310 R	CR HSF1 5310 V	CR HSF5 5310 R	CR HSF5 5310 V
4.425 112,40	5.500 139,70	0.562 14,27	CR HSF1 5353 R	CR HSF1 5353 V	CR HSF5 5353 R	CR HSF5 5353 V
4.437 112,70	5.465 138,81	0.583 14,81	CR HSF1 5351 R	CR HSF1 5351 V	CR HSF5 5351 R	CR HSF5 5351 V
4.874 123,80	5.874 149,20	0.500 12,70	CR HSF1 5391 R	CR HSF1 5391 V	CR HSF5 5391 R	CR HSF5 5391 V
5.205 132,21	6.504 165,20	0.591 15,01	CR HSF1 5431 R	CR HSF1 5431 V	CR HSF5 5431 R	CR HSF5 5431 V
5.622 142,80	6.622 168,20	0.625 15,88	CR HSF1 5471 R	CR HSF1 5471 V	CR HSF5 5471 R	CR HSF5 5471 V
5.750 146,05	7.000 177,80	0.625 15,88	CR HSF1 5489 R	CR HSF1 5489 V	CR HSF5 5489 R	CR HSF5 5489 V
5.874 149,20	7.000 177,80	0.492 12,50	CR HSF1 5498 R	CR HSF1 5498 V	CR HSF5 5498 R	CR HSF5 5498 V

Radial shaft seals – HSF1 (split) and HSF5 (solid) – inch dimensions

d₁ 6.000 – 17.000 in.

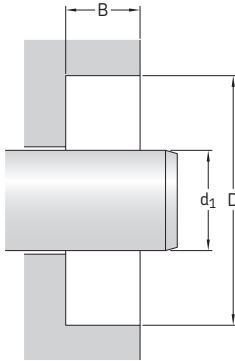

The table includes only a selection of available sizes. Contact your SKF sales representative for more information.

Please see pages 74 to 76 for housing bore requirements.

Dimensions		Designations		Solid version (HSF5)		
Shaft diameter d ₁	Bore diameter D	Bore depth B	Split version (HSF1) Lip material R	V	Lip material R	V
in./mm			–			
6.000 152,40	7.126 181,00	0.630 16,00	CR HSF1 5509 R	CR HSF1 5509 V	CR HSF5 5509 R	CR HSF5 5509 V
	7.500 190,50	0.625 15,88	CR HSF1 5510 R	CR HSF1 5510 V	CR HSF5 5510 R	CR HSF5 5510 V
6.500 165,10	8.000 203,20	0.750 19,05	CR HSF1 5570 R	CR HSF1 5570 V	CR HSF5 5570 R	CR HSF5 5570 V
6.748 171,40	7.750 196,85	0.750 19,05	CR HSF1 5585 R	CR HSF1 5585 V	CR HSF5 5585 R	CR HSF5 5585 V
7.000 177,80	8.000 203,20	0.437 11,10	CR HSF1 5587 R	CR HSF1 5587 V	CR HSF5 5587 R	CR HSF5 5587 V
	8.250 209,55	0.750 19,05	CR HSF1 5600 R	CR HSF1 5600 V	CR HSF5 5600 R	CR HSF5 5600 V
7.250 184,15	8.500 215,90	0.625 15,88	CR HSF1 5624 R	CR HSF1 5624 V	CR HSF5 5624 R	CR HSF5 5624 V
7.500 190,50	8.500 215,90	0.625 15,88	CR HSF1 5662 R	CR HSF1 5662 V	CR HSF5 5662 R	CR HSF5 5662 V
7.677 195,00	8.677 220,40	0.500 12,70	CR HSF1 5667 R	CR HSF1 5667 V	CR HSF5 5667 R	CR HSF5 5667 V
8.598 218,39	9.843 250,01	0.591 15,01	CR HSF1 5764 R	CR HSF1 5764 V	CR HSF5 5764 R	CR HSF5 5764 V
8.750 222,25	10.000 254,00	0.625 15,88	CR HSF1 5790 R	CR HSF1 5790 V	CR HSF5 5790 R	CR HSF5 5790 V
9.625 244,48	11.635 295,53	1.000 25,40	CR HSF1 5878 R	CR HSF1 5878 V	CR HSF5 5878 R	CR HSF5 5878 V
9.843 250,01	10.843 275,41	0.500 12,70	CR HSF1 5885 R	CR HSF1 5885 V	CR HSF5 5885 R	CR HSF5 5885 V
10.000 254,00	11.250 285,75	0.625 15,88	CR HSF1 5910 R	CR HSF1 5910 V	CR HSF5 5910 R	CR HSF5 5910 V
10.250 260,35	12.250 311,15	0.750 19,05	CR HSF1 5950 R	CR HSF1 5950 V	CR HSF5 5950 R	CR HSF5 5950 V

Dimensions Shaft diameter d ₁	Bore diameter D	Bore depth B	Designations		Solid version (HSF5)	
			Split version (HSF1) Lip material R	V	Lip material R	V
in./mm			–			
11.000 279,40	12.181 309,40	0.591 15,01	CR HSF1 6000 R	CR HSF1 6000 V	CR HSF5 6000 R	CR HSF5 6000 V
11.250 285,75	12.500 317,50	0.625 15,88	CR HSF1 6040 R	CR HSF1 6040 V	CR HSF5 6040 R	CR HSF5 6040 V
11.260 286,00	13.250 336,55	0.591 15,01	CR HSF1 6049 R	CR HSF1 6049 V	CR HSF5 6049 R	CR HSF5 6049 V
11.417 289,99	12.417 315,39	0.500 12,70	CR HSF1 6055 R	CR HSF1 6055 V	CR HSF5 6055 R	CR HSF5 6055 V
12.250 311,15	14.250 361,95	0.813 20,65	CR HSF1 6150 R	CR HSF1 6150 V	CR HSF5 6150 R	CR HSF5 6150 V
12.484 317,09	14.000 355,60	0.630 16,00	CR HSF1 6172 R	CR HSF1 6172 V	CR HSF5 6172 R	CR HSF5 6172 V
12.500 317,50	14.000 355,60	0.750 19,05	CR HSF1 6173 R	CR HSF1 6173 V	CR HSF5 6173 R	CR HSF5 6173 V
12.504 317,60	14.000 355,60	0.687 17,45	CR HSF1 6175 R	CR HSF1 6175 V	CR HSF5 6175 R	CR HSF5 6175 V
12.746 323,75	14.248 361,90	0.687 17,45	CR HSF1 6192 R	CR HSF1 6192 V	CR HSF5 6192 R	CR HSF5 6192 V
	14.750 374,65	1.000 25,40	CR HSF1 6195 R	CR HSF1 6195 V	CR HSF5 6195 R	CR HSF5 6195 V
13.000 330,20	14.500 368,30	0.687 17,45	CR HSF1 6230 R	CR HSF1 6230 V	CR HSF5 6230 R	CR HSF5 6230 V
	14.500 368,30	0.687 17,45	CR HSF1 6230 R	CR HSF1 6230 V	CR HSF5 6230 R	CR HSF5 6230 V
13.500 342,90	15.000 381,00	0.750 19,05	CR HSF1 6271 R	CR HSF1 6271 V	CR HSF5 6271 R	CR HSF5 6271 V
14.370 365,00	16.118 409,40	0.750 19,05	CR HSF1 6350 R	CR HSF1 6350 V	CR HSF5 6350 R	CR HSF5 6350 V
14.500 368,30	16.250 412,75	0.625 15,88	CR HSF1 6370 R	CR HSF1 6370 V	CR HSF5 6370 R	CR HSF5 6370 V
14.961 380,01	16.961 430,81	0.813 20,65	CR HSF1 6425 R	CR HSF1 6425 V	CR HSF5 6425 R	CR HSF5 6425 V
15.250 387,35	17.250 438,15	0.875 22,23	CR HSF1 6460 R	CR HSF1 6460 V	CR HSF5 6460 R	CR HSF5 6460 V
15.992 406,20	17.500 444,50	0.687 17,45	CR HSF1 6550 R	CR HSF1 6550 V	CR HSF5 6550 R	CR HSF5 6550 V
16.000 406,40	18.000 457,20	0.750 19,05	CR HSF1 6560 R	CR HSF1 6560 V	CR HSF5 6560 R	CR HSF5 6560 V
	18.000 457,20	0.813 20,65	CR HSF1 6565 R	CR HSF1 6565 V	CR HSF5 6565 R	CR HSF5 6565 V
	18.000 457,20	0.906 23,01	CR HSF1 6575 R	CR HSF1 6575 V	CR HSF5 6575 R	CR HSF5 6575 V
16.226 412,14	17.750 450,85	0.687 17,45	CR HSF1 6590 R	CR HSF1 6590 V	CR HSF5 6590 R	CR HSF5 6590 V
16.500 419,10	17.750 450,85	0.750 19,05	CR HSF1 6600 R	CR HSF1 6600 V	CR HSF5 6600 R	CR HSF5 6600 V
17.000 431,80	19.000 482,60	0.813 20,65	CR HSF1 6645 R	CR HSF1 6645 V	CR HSF5 6645 R	CR HSF5 6645 V

Radial shaft seals – HSF1 (split) and HSF5 (solid) – inch dimensions

d₁ 17.248 – 48.000 in.

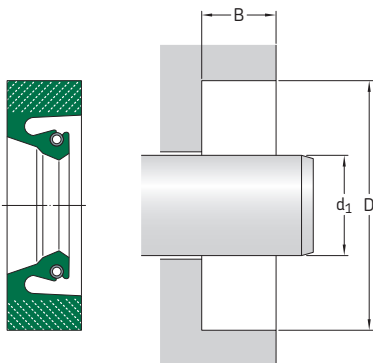

The table includes only a selection of available sizes. Contact your SKF sales representative for more information.

Please see **pages 74 to 76** for housing bore requirements.

Dimensions		Designations				
Shaft diameter d ₁	Bore diameter D	Bore depth B	Split version (HSF1) Lip material R	V	Solid version (HSF5) Lip material R	V
in./mm			–			
17.248 438,10	18.748 476,20	0.750 19,05	CR HSF1 6656 R	CR HSF1 6656 V	CR HSF5 6656 R	CR HSF5 6656 V
18.169 461,49	21.260 540,00	1.220 30,99	CR HSF1 6734 R	CR HSF1 6734 V	CR HSF5 6734 R	CR HSF5 6734 V
20.500 520,70	22.500 571,50	1.000 25,40	CR HSF1 6890 R	CR HSF1 6890 V	CR HSF5 6890 R	CR HSF5 6890 V
21.000 533,40	23.000 584,20	0.875 22,23	CR HSF1 6930 R	CR HSF1 6930 V	CR HSF5 6930 R	CR HSF5 6930 V
22.000 558,80	24.000 609,60	0.875 22,23	CR HSF1 7000 R	CR HSF1 7000 V	CR HSF5 7000 R	CR HSF5 7000 V
23.248 590,50	25.250 641,35	0.813 20,65	CR HSF1 7100 R	CR HSF1 7100 V	CR HSF5 7100 R	CR HSF5 7100 V
23.501 596,93	22.001 558,83	0.750 19,05	CR HSF1 6990 R	CR HSF1 6990 V	CR HSF5 6990 R	CR HSF5 6990 V
30.000 762,00	32.500 825,50	1.000 25,40	CR HSF1 7520 R	CR HSF1 7520 V	CR HSF5 7520 R	CR HSF5 7520 V
30.461 773,71	32.500 825,50	0.906 23,01	CR HSF1 7525 R	CR HSF1 7525 V	CR HSF5 7525 R	CR HSF5 7525 V
31.000 787,40	33.000 838,20	0.906 23,01	CR HSF1 7570 R	CR HSF1 7570 V	CR HSF5 7570 R	CR HSF5 7570 V
31.250 793,75	33.250 844,55	0.750 19,05	CR HSF1 7580 R	CR HSF1 7580 V	CR HSF5 7580 R	CR HSF5 7580 V
32.500 825,50	34.500 876,30	0.875 22,23	CR HSF1 7700 R	CR HSF1 7700 V	CR HSF5 7700 R	CR HSF5 7700 V
	34.500 876,30	1.000 25,40	CR HSF1 7710 R	CR HSF1 7710 V	CR HSF5 7710 R	CR HSF5 7710 V
33.000 838,20	35.000 889,00	0.906 23,01	CR HSF1 7730 R	CR HSF1 7730 V	CR HSF5 7730 R	CR HSF5 7730 V

Dimensions Shaft diameter d_1	Bore diameter D	Bore depth B	Designations		Solid version (HSF5)	
			Split version (HSF1) Lip material R	V	Lip material R	V
in./mm			–			
34.375 873,13	36.875 936,63	1.250 31,75	CR HSF1 7810 R	CR HSF1 7810 V	CR HSF5 7810 R	CR HSF5 7810 V
36.500 927,10	39.000 990,60	1.250 31,75	CR HSF1 7895 R	CR HSF1 7895 V	CR HSF5 7895 R	CR HSF5 7895 V
36.748 933,40	38.749 984,22	0.875 22,23	CR HSF1 7900 R	CR HSF1 7900 V	CR HSF5 7900 R	CR HSF5 7900 V
38.000 965,20	40.000 1016,00	0.875 22,23	CR HSF1 7990 R	CR HSF1 7990 V	CR HSF5 7990 R	CR HSF5 7990 V
39.118 993,60	40.000 1016,00	0.500 12,70	CR HSF1 8170 R	CR HSF1 8170 V	CR HSF5 8170 R	CR HSF5 8170 V
48.000 1219,20	49.000 1244,60	1.260 32,00	CR HSF1 8400 R	CR HSF1 8400 V	CR HSF5 8400 R	CR HSF5 8400 V

2.20

Radial shaft seals – HSF2 (split) and HSF6 (solid) – metric dimensions

d_1 127 – 800 mm

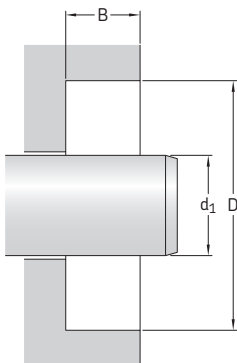

The table includes only a selection of available sizes. Contact your SKF sales representative for more information.

Please see **pages 74 to 76** for housing bore requirements.

Dimensions		Designations		
Shaft diameter d_1	Bore diameter D	Bore depth B	Split version (HSF2) Lip material R, V	Solid version (HSF6) Lip material R, V
mm			–	
127	158,80	12,30	CR 127×159×12 HSF2 R CR 127×159×12 HSF2 V	CR 127×159×12 HSF6 R CR 127×159×12 HSF6 V
275	319,50	19	CR 275×320×19 HSF2 R CR 275×320×19 HSF2 V	CR 275×320×19 HSF6 R CR 275×320×19 HSF6 V
320	364	18	CR 320×364×18 HSF2 R CR 320×364×18 HSF2 V	CR 320×364×18 HSF6 R CR 320×364×18 HSF6 V
800	864	21,60	CR 800×864×22 HSF2 R CR 800×864×22 HSF2 V	CR 800×864×22 HSF6 R CR 800×864×22 HSF6 V

Radial shaft seals – HSF2 (split) and HSF6 (solid) – inch dimensions
 d_1 21.000 in.

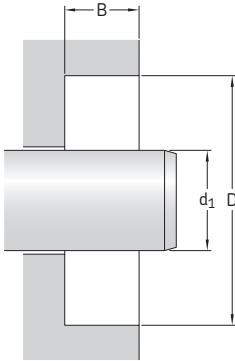

The table includes only a selection of available sizes. Contact your SKF sales representative for more information.

Please see **pages 74 to 76** for housing bore requirements.

Dimensions		Designations				
Shaft diameter d_1	Bore diameter D	Bore depth B	Split version (HSF2) Lip material R	V	Solid version (HSF6) Lip material R	V
in./mm			–			
21.000 533,40	23.000 584,20	0.875 22,23	CR HSF2 6930 R	CR HSF2 6930 V	CR HSF6 6930 R	CR HSF6 6930 V

Radial shaft seals – HSF3 (split) and HSF7 (solid) – metric dimensions

d_1 80 – 380 mm

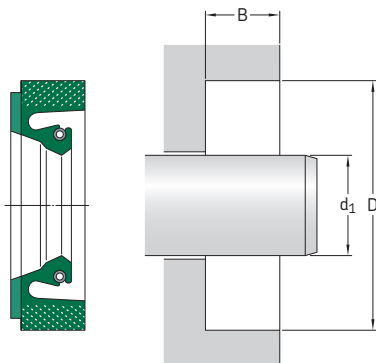

The table includes only a selection of available sizes. Contact your SKF sales representative for more information.

Please see **pages 74 to 76** for housing bore requirements.

Dimensions		Bore depth B	Designations	
Shaft diameter d_1	Bore diameter D		Split version (HSF3) Lip material R, V	Solid version (HSF7) Lip material R, V
mm				
80	95	10	CR 80×95×10 HSF3 R CR 80×95×10 HSF3 V	CR 80×95×10 HSF7 R CR 80×95×10 HSF7 V
100	130	12,50	CR 100×130×13 HSF3 R CR 100×130×13 HSF3 V	CR 100×130×13 HSF7 R CR 100×130×13 HSF7 V
140	180	16	CR 140×180×16 HSF3 R CR 140×180×16 HSF3 V	CR 140×180×16 HSF7 R CR 140×180×16 HSF7 V
150	190	16	CR 150×190×16 HSF3 R CR 150×190×16 HSF3 V	CR 150×190×16 HSF7 R CR 150×190×16 HSF7 V
160	200	16	CR 160×200×16 HSF3 R CR 160×200×16 HSF3 V	CR 160×200×16 HSF7 R CR 160×200×16 HSF7 V
165	195	15	CR 165×195×15 HSF3 R CR 165×195×15 HSF3 V	CR 165×195×15 HSF7 R CR 165×195×15 HSF7 V
220	250	15	CR 220×250×15 HSF3 R CR 220×250×15 HSF3 V	CR 220×250×15 HSF7 R CR 220×250×15 HSF7 V
	260	18	CR 220×260×18 HSF3 R CR 220×260×18 HSF3 V	CR 220×260×18 HSF7 R CR 220×260×18 HSF7 V
230	270	16	CR 230×270×16 HSF3 R CR 230×270×16 HSF3 V	CR 230×270×16 HSF7 R CR 230×270×16 HSF7 V
235	265	15,30	CR 235×265×15 HSF3 R CR 235×265×15 HSF3 V	CR 235×265×15 HSF7 R CR 235×265×15 HSF7 V
240	280	18	CR 240×280×18 HSF3 R CR 240×280×18 HSF3 V	CR 240×280×18 HSF7 R CR 240×280×18 HSF7 V
	290	25	CR 240×290×25 HSF3 R CR 240×290×25 HSF3 V	CR 240×290×25 HSF7 R CR 240×290×25 HSF7 V
245	285	16	CR 245×285×16 HSF3 R CR 245×285×16 HSF3 V	CR 245×285×16 HSF7 R CR 245×285×16 HSF7 V
250	280	16	CR 250×280×16 HSF3 R CR 250×280×16 HSF3 V	CR 250×280×16 HSF7 R CR 250×280×16 HSF7 V
	290	16,50	CR 250×290×17 HSF3 R CR 250×290×17 HSF3 V	CR 250×290×17 HSF7 R CR 250×290×17 HSF7 V

Dimensions Shaft diameter d_1	Bore diameter D	Bore depth B	Designations	
			Split version (HSF3) Lip material R, V	Solid version (HSF7) Lip material R, V
mm			–	
270	310	18	CR 270×310×18 HSF3 R CR 270×310×18 HSF3 V	CR 270×310×18 HSF7 R CR 270×310×18 HSF7 V
280	320	18	CR 280×320×18 HSF3 R CR 280×320×18 HSF3 V	CR 280×320×18 HSF7 R CR 280×320×18 HSF7 V
285	325	18	CR 285×325×18 HSF3 R CR 285×325×18 HSF3 V	CR 285×325×18 HSF7 R CR 285×325×18 HSF7 V
290	334	20,30	CR 290×334×20 HSF3 R CR 290×334×20 HSF3 V	CR 290×334×20 HSF7 R CR 290×334×20 HSF7 V
300	340	16,50	CR 300×340×17 HSF3 R CR 300×340×17 HSF3 V	CR 300×340×17 HSF7 R CR 300×340×17 HSF7 V
	340	18	CR 300×340×18 HSF3 R CR 300×340×18 HSF3 V	CR 300×340×18 HSF7 R CR 300×340×18 HSF7 V
	344	20	CR 300×344×20 HSF3 R CR 300×344×20 HSF3 V	CR 300×344×20 HSF7 R CR 300×344×20 HSF7 V
	344	20	CR 300×344×20 HSF3 R CR 300×344×20 HSF3 V	CR 300×344×20 HSF7 R CR 300×344×20 HSF7 V
310	353	20	CR 310×353×20 HSF3 R CR 310×353×20 HSF3 V	CR 310×353×20 HSF7 R CR 310×353×20 HSF7 V
	354	20	CR 310×354×20 HSF3 R CR 310×354×20 HSF3 V	CR 310×354×20 HSF7 R CR 310×354×20 HSF7 V
315	360	20	CR 315×360×20 HSF3 R CR 315×360×20 HSF3 V	CR 315×360×20 HSF7 R CR 315×360×20 HSF7 V
320	350	15	CR 320×350×15 HSF3 R CR 320×350×15 HSF3 V	CR 320×350×15 HSF7 R CR 320×350×15 HSF7 V
	360	17,70	CR 320×360×18 HSF3 R CR 320×360×18 HSF3 V	CR 320×360×18 HSF7 R CR 320×360×18 HSF7 V
325	365	16	CR 325×365×16 HSF3 R CR 325×365×16 HSF3 V	CR 325×365×16 HSF7 R CR 325×365×16 HSF7 V
330	370	20	CR 330×370×20 HSF3 R CR 330×370×20 HSF3 V	CR 330×370×20 HSF7 R CR 330×370×20 HSF7 V
	374	20	CR 330×374×20 HSF3 R CR 330×374×20 HSF3 V	CR 330×374×20 HSF7 R CR 330×374×20 HSF7 V
340	372	16	CR 340×372×16 HSF3 R CR 340×372×16 HSF3 V	CR 340×372×16 HSF7 R CR 340×372×16 HSF7 V
345	389	20	CR 345×389×20 HSF3 R CR 345×389×20 HSF3 V	CR 345×389×20 HSF7 R CR 345×389×20 HSF7 V
350	390	18	CR 350×390×18 HSF3 R CR 350×390×18 HSF3 V	CR 350×390×18 HSF7 R CR 350×390×18 HSF7 V
	394	20	CR 350×394×20 HSF3 R CR 350×394×20 HSF3 V	CR 350×394×20 HSF7 R CR 350×394×20 HSF7 V
	394	22	CR 350×394×22 HSF3 R CR 350×394×22 HSF3 V	CR 350×394×22 HSF7 R CR 350×394×22 HSF7 V
360	404	20	CR 360×404×20 HSF3 R CR 360×404×20 HSF3 V	CR 360×404×20 HSF7 R CR 360×404×20 HSF7 V
365	409,40	19,05	CR 365×409×19 HSF3 R CR 365×409×19 HSF3 V	CR 365×409×19 HSF7 R CR 365×409×19 HSF7 V
366	410	20	CR 366×410×20 HSF3 R CR 366×410×20 HSF3 V	CR 366×410×20 HSF7 R CR 366×410×20 HSF7 V
370	410	18	CR 370×410×18 HSF3 R CR 370×410×18 HSF3 V	CR 370×410×18 HSF7 R CR 370×410×18 HSF7 V
380	419	24	CR 380×419×24 HSF3 R CR 380×419×24 HSF3 V	CR 380×419×24 HSF7 R CR 380×419×24 HSF7 V
	424	20	CR 380×424×20 HSF3 R CR 380×424×20 HSF3 V	CR 380×424×20 HSF7 R CR 380×424×20 HSF7 V

Radial shaft seals – HSF3 (split) and HSF7 (solid) – metric dimensions

d_1 385 – 750 mm

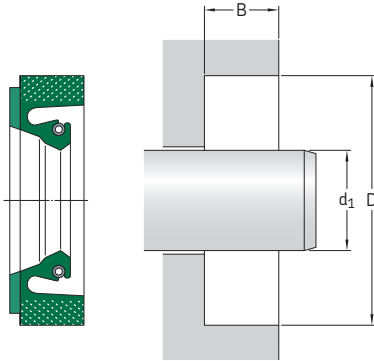

The table includes only a selection of available sizes. Contact your SKF sales representative for more information.

Please see pages 74 to 76 for housing bore requirements.

Dimensions		Bore depth B	Designations	Solid version (HSF7)
Shaft diameter d_1	Bore diameter D		Split version (HSF3) Lip material R, V	Lip material R, V
mm				
385	425	18,30	CR 385×425×18 HSF3 R	CR 385×425×18 HSF7 R
			CR 385×425×18 HSF3 V	CR 385×425×18 HSF7 V
387	431	22,50	CR 387×431×23 HSF3 R	CR 387×431×23 HSF7 R
			CR 387×431×23 HSF3 V	CR 387×431×23 HSF7 V
390	430	18	CR 390×430×18 HSF3 R	CR 390×430×18 HSF7 R
			CR 390×430×18 HSF3 V	CR 390×430×18 HSF7 V
400	440	18	CR 400×440×18 HSF3 R	CR 400×440×18 HSF7 R
			CR 400×440×18 HSF3 V	CR 400×440×18 HSF7 V
	440	22	CR 400×440×22 HSF3 R	CR 400×440×22 HSF7 R
			CR 400×440×22 HSF3 V	CR 400×440×22 HSF7 V
	444	20	CR 400×444×20 HSF3 R	CR 400×444×20 HSF7 R
			CR 400×444×20 HSF3 V	CR 400×444×20 HSF7 V
450	22	CR 400×450×22 HSF3 R	CR 400×450×22 HSF7 R	
		CR 400×450×22 HSF3 V	CR 400×450×22 HSF7 V	
420	470	22	CR 420×470×22 HSF3 R	CR 420×470×22 HSF7 R
			CR 420×470×22 HSF3 V	CR 420×470×22 HSF7 V
430	480	22	CR 430×480×22 HSF3 R	CR 430×480×22 HSF7 R
			CR 430×480×22 HSF3 V	CR 430×480×22 HSF7 V
440	490	22	CR 440×490×22 HSF3 R	CR 440×490×22 HSF7 R
			CR 440×490×22 HSF3 V	CR 440×490×22 HSF7 V
450	494	20	CR 450×494×20 HSF3 R	CR 450×494×20 HSF7 R
			CR 450×494×20 HSF3 V	CR 450×494×20 HSF7 V
460	510	22	CR 460×510×22 HSF3 R	CR 460×510×22 HSF7 R
			CR 460×510×22 HSF3 V	CR 460×510×22 HSF7 V
480	530	22	CR 480×530×22 HSF3 R	CR 480×530×22 HSF7 R
			CR 480×530×22 HSF3 V	CR 480×530×22 HSF7 V
500	544	20	CR 500×544×20 HSF3 R	CR 500×544×20 HSF7 R
			CR 500×544×20 HSF3 V	CR 500×544×20 HSF7 V
515	555	20	CR 515×555×20 HSF3 R	CR 515×555×20 HSF7 R
			CR 515×555×20 HSF3 V	CR 515×555×20 HSF7 V

Dimensions Shaft diameter d ₁	Bore diameter D	Bore depth B	Designations	
			Split version (HSF3) Lip material R, V	Solid version (HSF7) Lip material R, V
mm			-	
520	564	20	CR 520×564×20 HSF3 R CR 520×564×20 HSF3 V CR 520×570×22 HSF3 R CR 520×570×22 HSF3 V	CR 520×564×20 HSF7 R CR 520×564×20 HSF7 V CR 520×570×22 HSF7 R CR 520×570×22 HSF7 V
	570	22		
530	580	22	CR 530×580×22 HSF3 R CR 530×580×22 HSF3 V	CR 530×580×22 HSF7 R CR 530×580×22 HSF7 V
540	590	22	CR 540×590×22 HSF3 R CR 540×590×22 HSF3 V CR 540×590×25 HSF3 R CR 540×590×25 HSF3 V	CR 540×590×22 HSF7 R CR 540×590×22 HSF7 V CR 540×590×25 HSF7 R CR 540×590×25 HSF7 V
	590	25		
545	596,90	19,05	CR 545×597×19 HSF3 R CR 545×597×19 HSF3 V	CR 545×597×19 HSF7 R CR 545×597×19 HSF7 V
550	600	22	CR 550×600×22 HSF3 R CR 550×600×22 HSF3 V	CR 550×600×22 HSF7 R CR 550×600×22 HSF7 V
560	603	20	CR 560×603×20 HSF3 R CR 560×603×20 HSF3 V CR 560×604×20 HSF3 R CR 560×604×20 HSF3 V	CR 560×603×20 HSF7 R CR 560×603×20 HSF7 V CR 560×604×20 HSF7 R CR 560×604×20 HSF7 V
	604	20		
580	630	22	CR 580×630×22 HSF3 R CR 580×630×22 HSF3 V	CR 580×630×22 HSF7 R CR 580×630×22 HSF7 V
590	640	22	CR 590×640×22 HSF3 R CR 590×640×22 HSF3 V	CR 590×640×22 HSF7 R CR 590×640×22 HSF7 V
600	640	18	CR 600×640×18 HSF3 R CR 600×640×18 HSF3 V	CR 600×640×18 HSF7 R CR 600×640×18 HSF7 V
614	658	20	CR 614×658×20 HSF3 R CR 614×658×20 HSF3 V	CR 614×658×20 HSF7 R CR 614×658×20 HSF7 V
620	670	22	CR 620×670×22 HSF3 R CR 620×670×22 HSF3 V	CR 620×670×22 HSF7 R CR 620×670×22 HSF7 V
640	680	20	CR 640×680×20 HSF3 R CR 640×680×20 HSF3 V	CR 640×680×20 HSF7 R CR 640×680×20 HSF7 V
650	700	22	CR 650×700×22 HSF3 R CR 650×700×22 HSF3 V	CR 650×700×22 HSF7 R CR 650×700×22 HSF7 V
660	700	18	CR 660×700×18 HSF3 R CR 660×700×18 HSF3 V	CR 660×700×18 HSF7 R CR 660×700×18 HSF7 V
665	715	22	CR 665×715×22 HSF3 R CR 665×715×22 HSF3 V	CR 665×715×22 HSF7 R CR 665×715×22 HSF7 V
670	714	22	CR 670×714×22 HSF3 R CR 670×714×22 HSF3 V	CR 670×714×22 HSF7 R CR 670×714×22 HSF7 V
700	764	25	CR 700×764×25 HSF3 R CR 700×764×25 HSF3 V	CR 700×764×25 HSF7 R CR 700×764×25 HSF7 V
710	774	25	CR 710×774×25 HSF3 R CR 710×774×25 HSF3 V	CR 710×774×25 HSF7 R CR 710×774×25 HSF7 V
724	775	22	CR 724×775×22 HSF3 R CR 724×775×22 HSF3 V	CR 724×775×22 HSF7 R CR 724×775×22 HSF7 V
740	780	16,50	CR 740×780×17 HSF3 R CR 740×780×17 HSF3 V	CR 740×780×17 HSF7 R CR 740×780×17 HSF7 V
750	814	28	CR 750×814×28 HSF3 R CR 750×814×28 HSF3 V	CR 750×814×28 HSF7 R CR 750×814×28 HSF7 V

Radial shaft seals – HSF3 (split) and HSF7 (solid) – metric dimensions

d_1 775 – 985 mm

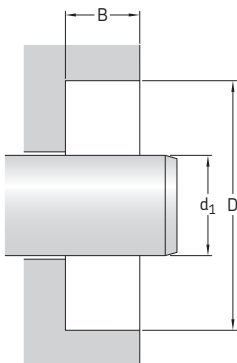

The table includes only a selection of available sizes. Contact your SKF sales representative for more information.

Please see **pages 74 to 76** for housing bore requirements.

Dimensions		Designations		
Shaft diameter d_1	Bore diameter D	Bore depth B	Split version (HSF3) Lip material R, V	Solid version (HSF7) Lip material R, V
mm			–	
775	839	25	CR 775×839×25 HSF3 R CR 775×839×25 HSF3 V	CR 775×839×25 HSF7 R CR 775×839×25 HSF7 V
790	834	25	CR 790×834×25 HSF3 R CR 790×834×25 HSF3 V	CR 790×834×25 HSF7 R CR 790×834×25 HSF7 V
	854	25	CR 790×854×25 HSF3 R CR 790×854×25 HSF3 V	CR 790×854×25 HSF7 R CR 790×854×25 HSF7 V
800	864	25	CR 800×864×25 HSF3 R CR 800×864×25 HSF3 V	CR 800×864×25 HSF7 R CR 800×864×25 HSF7 V
840	880	18	CR 840×880×18 HSF3 R CR 840×880×18 HSF3 V	CR 840×880×18 HSF7 R CR 840×880×18 HSF7 V
880	944	25,40	CR 880×944×25.4 HSF3 R CR 880×944×25.4 HSF3 V	CR 880×944×25.4 HSF7 R CR 880×944×25.4 HSF7 V
890	930	18	CR 890×930×18 HSF3 R CR 890×930×18 HSF3 V	CR 890×930×18 HSF7 R CR 890×930×18 HSF7 V
910	974	25	CR 910×974×25 HSF3 R CR 910×974×25 HSF3 V	CR 910×974×25 HSF7 R CR 910×974×25 HSF7 V
970	1 034	25	CR 970×1034×25 HSF3 R CR 970×1034×25 HSF3 V	CR 970×1034×25 HSF7 R CR 970×1034×25 HSF7 V
985	1 045	25	CR 985×1045×25 HSF3 R CR 985×1045×25 HSF3 V	CR 985×1045×25 HSF7 R CR 985×1045×25 HSF7 V

Radial shaft seals – HSF3 (split) and HSF7 (solid) – inch dimensions

d_1 8.500 – 45.500 in.

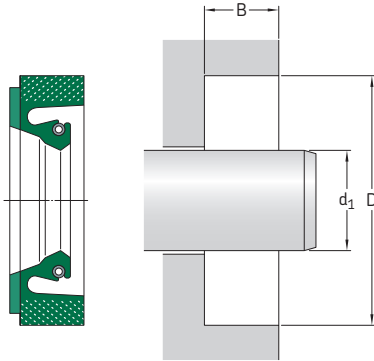

The table includes only a selection of available sizes. Contact your SKF sales representative for more information.

Please see pages 74 to 76 for housing bore requirements.

Dimensions		Designations				
Shaft diameter d_1	Bore diameter D	Bore depth B	Split version (HSF3) Lip material R	V	Solid version (HSF7) Lip material R	V
in./mm			–			
8.500 215,90	9.750 247,65	0.813 20,65	CR HSF3 5766 R	CR HSF3 5766 V	CR HSF7 5766 R	CR HSF7 5766 V
10.000 254,00	11.500 292,10	0.630 16,00	CR HSF3 5920 R	CR HSF3 5920 V	CR HSF7 5920 R	CR HSF7 5920 V
11.500 292,10	13.780 350,01	0.630 16,00	CR HSF3 6075 R	CR HSF3 6075 V	CR HSF7 6075 R	CR HSF7 6075 V
12.250 311,15	14.250 361,95	0.813 20,65	CR HSF3 6150 R	CR HSF3 6150 V	CR HSF7 6150 R	CR HSF7 6150 V
14.500 368,30	16.500 419,10	0.813 20,65	CR HSF3 6370 R	CR HSF3 6370 V	CR HSF7 6370 R	CR HSF7 6370 V
	16.500 419,10	1.152 29,26	CR HSF3 6375 R	CR HSF3 6375 V	CR HSF7 6375 R	CR HSF7 6375 V
14.750 374,65	16.500 419,10	0.875 22,23	CR HSF3 6395 R	CR HSF3 6395 V	CR HSF7 6395 R	CR HSF7 6395 V
15.250 387,35	17.250 438,15	1.000 25,40	CR HSF3 6465 R	CR HSF3 6465 V	CR HSF7 6465 R	CR HSF7 6465 V
16.500 419,10	18.000 457,20	0.750 19,05	CR HSF3 6611 R	CR HSF3 6611 V	CR HSF7 6611 R	CR HSF7 6611 V
35.500 901,70	37.500 952,50	0.875 22,23	CR HSF3 7860 R	CR HSF3 7860 V	CR HSF7 7860 R	CR HSF7 7860 V
36.000 914,40	38.500 977,90	0.875 22,23	CR HSF3 7890 R	CR HSF3 7890 V	CR HSF7 7890 R	CR HSF7 7890 V
45.500 1 155,70	47.000 1 193,80	0.813 20,65	CR HSF3 9000 R	CR HSF3 9000 V	CR HSF7 9000 R	CR HSF7 9000 V

Radial shaft seals – HSF4 (split) and HSF8 (solid) – metric dimensions

d_1 75 – 660 mm

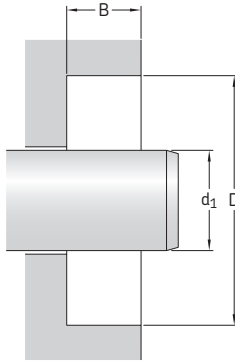

The table includes only a selection of available sizes. Contact your SKF sales representative for more information.

Please see **pages 74 to 76** for housing bore requirements.

Dimensions		Designations		
Shaft diameter d_1	Bore diameter D	Bore depth B	Split version (HSF4) Lip material R, V	Solid version (HSF8) Lip material R, V
mm			–	
75	107	12,50	CR 75×107×13 HSF4 R CR 75×107×13 HSF4 V	CR 75×107×13 HSF8 R CR 75×107×13 HSF8 V
105	145	16	CR 105×145×16 HSF4 R CR 105×145×16 HSF4 V	CR 105×145×16 HSF8 R CR 105×145×16 HSF8 V
215	250	16	CR 215×250×16 HSF4 R CR 215×250×16 HSF4 V	CR 215×250×16 HSF8 R CR 215×250×16 HSF8 V
300	340	16	CR 300×340×16 HSF4 R CR 300×340×16 HSF4 V	CR 300×340×16 HSF8 R CR 300×340×16 HSF8 V
330	374	20	CR 330×374×20 HSF4 R CR 330×374×20 HSF4 V	CR 330×374×20 HSF8 R CR 330×374×20 HSF8 V
370	410	15	CR 370×410×15 HSF4 R CR 370×410×15 HSF4 V	CR 370×410×15 HSF8 R CR 370×410×15 HSF8 V
	420	20	CR 380×420×20 HSF4 R CR 380×420×20 HSF4 V	CR 380×420×20 HSF8 R CR 380×420×20 HSF8 V
380	420	22	CR 380×420×22 HSF4 R CR 380×420×22 HSF4 V	CR 380×420×22 HSF8 R CR 380×420×22 HSF8 V
	490	20	CR 440×490×20 HSF4 R CR 440×490×20 HSF4 V	CR 440×490×20 HSF8 R CR 440×490×20 HSF8 V
440	490	22	CR 440×490×22 HSF4 R CR 440×490×22 HSF4 V	CR 440×490×22 HSF8 R CR 440×490×22 HSF8 V
450	500	22	CR 450×500×22 HSF4 R CR 450×500×22 HSF4 V	CR 450×500×22 HSF8 R CR 450×500×22 HSF8 V
460	500	16	CR 460×500×16 HSF4 R CR 460×500×16 HSF4 V	CR 460×500×16 HSF8 R CR 460×500×16 HSF8 V
500	540	22	CR 500×540×22 HSF4 R CR 500×540×22 HSF4 V	CR 500×540×22 HSF8 R CR 500×540×22 HSF8 V
660	704	20	CR 660×704×20 HSF4 R CR 660×704×20 HSF4 V	CR 660×704×20 HSF8 R CR 660×704×20 HSF8 V

Radial shaft seals – HSF4 (split) and HSF8 (solid) – inch dimensions
 d_1 38.000 in.

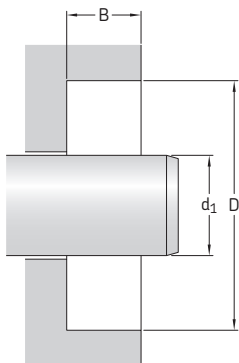

The table includes only a selection of available sizes. Contact your SKF sales representative for more information.

Please see **pages 74 to 76** for housing bore requirements.

Dimensions		Designations				
Shaft diameter d_1	Bore diameter D	Bore depth B	Split version (HSF4) Lip material R	V	Solid version (HSF8) Lip material R	V
in./mm			–			
38,000 965,20	40,000 1 016,00	0,875 22,23	CR HSF4 7990 R	CR HSF4 7990 V	CR HSF8 7990 R	CR HSF8 7990 V

Radial shaft seals – HSF9 – metric dimensions

d_1 200 – 860 mm

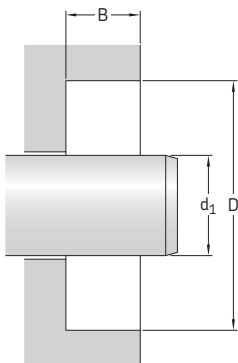
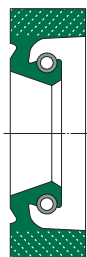

The table includes only a selection of available sizes. Contact your SKF sales representative for more information.

Please see **pages 74 to 76** for housing bore requirements.

Dimensions		Bore depth B	Designations	
Shaft diameter d_1	Bore diameter D		Lip material R	V
mm			–	
200	240	16,50	CR 200×240×17 HSF9 R	CR 200×240×17 HSF9 V
335	379	20	CR 335×379×20 HSF9 R	CR 335×379×20 HSF9 V
346	390	18	CR 346×390×18 HSF9 R	CR 346×390×18 HSF9 V
360	404	17,45	CR 360×404×17 HSF9 R	CR 360×404×17 HSF9 V
480	530	22	CR 480×530×22 HSF9 R	CR 480×530×22 HSF9 V
500	540	20	CR 500×540×20 HSF9 R	CR 500×540×20 HSF9 V
515	555	20	CR 515×555×20 HSF9 R	CR 515×555×20 HSF9 V
600	644	20	CR 600×644×20 HSF9 R	CR 600×644×20 HSF9 V
700	750	25	CR 700×750×25 HSF9 R	CR 700×750×25 HSF9 V
751	814	25,40	CR 751×814×25 HSF9 R	CR 751×814×25 HSF9 V
840	904	25	CR 840×904×25 HSF9 R	CR 840×904×25 HSF9 V
860	924	25	CR 860×924×25 HSF9 R	CR 860×924×25 HSF9 V

Radial shaft seals – HSF9 – inch dimensions

d_1 17.875 – 25.996 in.

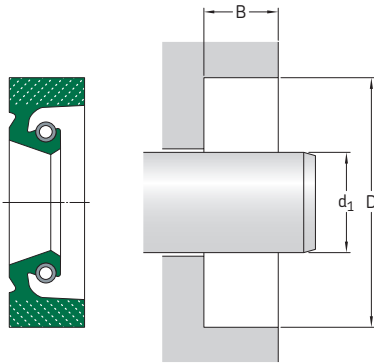

The table includes only a selection of available sizes. Contact your SKF sales representative for more information.

Please see pages 74 to 76 for housing bore requirements.

Dimensions		Designations		
Shaft diameter d_1	Bore diameter D	Bore depth B	Lip material	
			R	V
in./mm		–		
17.875 454,03	19.850 504,19	0.813 20,65	CR HSF9 6715 R	CR HSF9 6715 V
25.996 660,30	28.000 711,20	1.000 25,40	CR HSF9 7233 R	CR HSF9 7233 V

Radial shaft seals – HS4 and HS5 – metric dimensions

d_1 230 – 1 055 mm

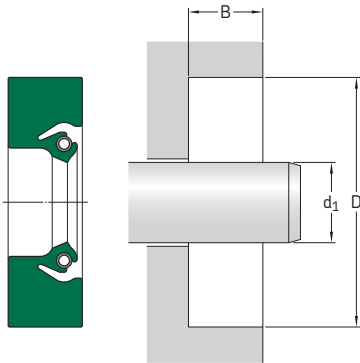

The table includes only a selection of available sizes. Contact your SKF sales representative for more information.

Please see **pages 74 to 76** for housing bore requirements.

Dimensions	Bore diameter	Bore depth	Design	Lip material	Designation
Shaft diameter d_1	D	B			
mm			–	–	–
230	269	22	HS5	R	CR 230×269×22 HS5 R
240	279	22	HS5	R	CR 240×279×22 HS5 R
245	290	15	HS4	V	CR 245×290×15 HS4 V
260	285,40	12,70	HS5	R	CR 260×285×13 HS5 R
280	325	24	HS5	R	CR 280×325×24 HS5 R
310	354	20	HS5	R	CR 310×354×20 HS5 R
315	355	16	HS4	V	CR 315×355×16 HS4 V
325	368	20	HS5	R	CR 325×368×20 HS5 R
350	400	25,40	HS5	R	CR 350×400×25 HS5 R
360	390	18	HS5	H	CR 360×390×18 HS5 H
390	434	20	HS5	R	CR 390×434×20 HS5 R
400	444	20	HS5	R	CR 400×444×20 HS5 R
	447	20	HS5	R	CR 400×447×20 HS5 R
	450	25	HS5	R	CR 400×450×25 HS5 R
410	454	20	HS5	R	CR 410×454×20 HS5 R
470	520	20,70	HS4	R	CR 470×520×21 HS4 R
475	525	25	HS4	R	CR 475×525×25 HS4 R
480	530	25	HS5	R	CR 480×530×25 HS5 R
490	530	20,50	HS5	D	CR 490×530×21 HS5 D
515	555	20	HS5	R	CR 515×555×20 HS5 R
519	560	25	HS5	D	CR 519×560×25 HS5 D
520	570	24	HS5	R	CR 520×570×24 HS5 R

Dimensions			Design	Lip material	Designation
Shaft diameter d_1	Bore diameter D	Bore depth B			
mm			–	–	–
525	575	20,70	HS4	R	CR 525×575×21 HS4 R
530	575	20	HS5	R	CR 530×575×20 HS5 R
540	584	20	HS4	R	CR 540×584×20 HS4 R
700	740	20	HS5	D	CR 700×740×20 HS5 D
710	760	25	HS5	D	CR 710×760×25 HS5 D
712	757	20,50	HS5	D	CR 712×757×21 HS5 D
778	818	20,50	HS5	D	CR 778×818×21 HS5 D
780	830	22	HS5	R	CR 780×830×22 HS5 R
910	966	17,86	HS5	R	CR 910×966×18 HS5 R
978	1 018	18	HS5	R	CR 978×1018×18 HS5 R
1 055	1 100	25	HS5	R	CR 1055×1100×25 HS5 R
	1 100	25	HS5	D	CR 1055×1100×25 HS5 D

Radial shaft seals – HS4 and HS5 – inch dimensions

d_1 6.438– 72.750 in.

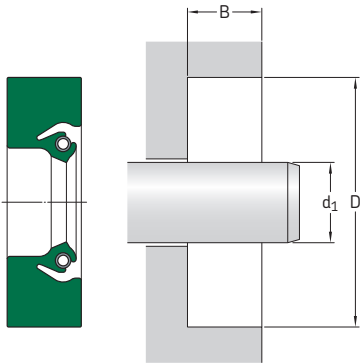

The table includes only a selection of available sizes. Contact your SKF sales representative for more information.

Please see pages 74 to 76 for housing bore requirements.

Dimensions		Bore diameter D	Bore depth B	Design	Lip material	Designation
Shaft diameter d_1						
in./mm						
6.438 163,53	7.688 195,28	0.625 15,88	HS5	R	CR 596043	
7.125 180,98	8.125 206,38	0.500 12,70	HS5	R	CR 595761	
7.188 182,58	8.640 219,46	0.625 15,88	HS5	R	CR 595643	
7.500 190,50	8.750 222,25	0.625 15,88	HS5	D	CR 595822	
7.750 196,85	8.750 222,25	0.625 15,88	HS5	D	CR 595813	
8.000 203,20	9.500 241,30	0.625 15,88	HS5	R	CR 595404	
8.625 219,08	10.125 257,18	0.609 15,47	HS5	R	CR 595566	
9.000 228,60	10.500 266,70	0.625 15,88	HS5	R	CR 594641	
10.250 260,35	12.017 305,23	0.750 19,05	HS5	R	CR 1025435	
11.250 285,75	12.750 323,85	0.625 15,88	HS5	R	CR 1125235	
11.500 292,10	13.250 336,55	0.750 19,05	HS5	R	CR 594850	
12.000 304,80	13.000 330,20	0.500 12,70	HS5	R	CR 1200015	
12.250 311,15	13.750 349,25	0.750 19,05	HS5	R	CR 1225125	
13.375 339,73	14.875 377,83	0.625 15,88	HS5	R	CR 1338235	

Dimensions			Design	Lip material	Designation
Shaft diameter d_1	Bore diameter D	Bore depth B			
in./mm			–	–	–
13.500 342,90	15,000 381,00	0.625 15,88	HS5	D	CR 1350235
13.985 355,22	15,500 393,70	0.625 15,88	HS4	R	CR 526447
14.361 364,77	15,748 400,00	0.709 18,01	HS4	R	CR 595175
15.748 400,00	17,717 450,01	0.890 22,61	HS4	R	CR 1574443
16.000 406,40	17,000 431,80	0.500 12,70	HS4	R	CR 1600014
20.000 508,00	22,000 558,80	0.500 12,70	HS5	R	CR 595044
21.000 533,40	23,000 584,20	0.813 20,65	HS4	R	CR 526719
21.750 552,45	23,250 590,55	0.625 15,88	HS5	R	CR 593520
24.000 609,60	25,500 647,70	0.750 19,05	HS5	R	CR 593519
25.000 635,00	27,000 685,80	0.875 22,23	HS5	R	CR 593183
27.000 685,80	29,000 736,60	0.813 20,65	HS5	R	CR 2700555
33.000 838,20	34,250 869,95	0.625 15,88	HS5	D	CR 530414
53.000 1346,20	54,875 1393,83	0.813 20,65	HS4	R	CR 595881
72.750 1847,85	74,000 1879,60	0.719 18,26	HS5	R	CR 7275135

2.25

Radial shaft seals – HS6, HS7 and HS8 – metric dimensions

d_1 145 – 460 mm

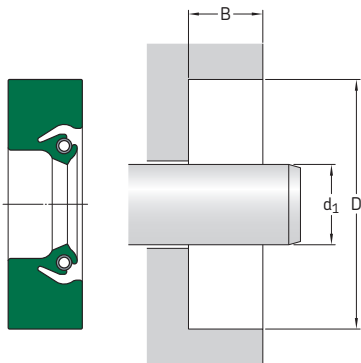

The table includes only a selection of available sizes. Contact your SKF sales representative for more information.

Please see **pages 74 to 76** for housing bore requirements.

Dimensions		Bore depth B	Design	Lip material	Designation
Shaft diameter d_1	Bore diameter D				
mm					
145	175	14	HS8	R	CR 145×175×14 HS8 R
150	180	15,88	HS8	R	CR 150×180×16 HS8 R
160	200	15,88	HS8	D	CR 160×200×16 HS8 D
170	200	16	HS8	V	CR 170×200×16 HS8 V
180	222	16	HS7	R	CR 180×222×16 HS7 R
185	220	12,70	HS8	R	CR 185×220×13 HS8 R
186	226	16	HS8	R	CR 186×226×16 HS8 R
190	220	16	HS8	R	CR 190×220×16 HS8 R
	230	16	HS8	R	CR 190×230×16 HS8 R
200	238	19	HS6	R	CR 200×238×19 HS6 R
	238,10	19,10	HS8	R	CR 200×238×19 HS8 R
220	250	15	HS8	R	CR 220×250×15 HS8 R
	250	16	HS8	D	CR 220×250×16 HS8 D
	260	14,27	HS8	R	CR 220×260×14 HS8 R
	260	15	HS8	R	CR 220×260×15 HS8 R
	260	16	HS8	R	CR 220×260×16 HS8 R
230	260	15	HS8	R	CR 230×260×15 HS8 R
240	270	15	HS8	R	CR 240×270×15 HS8 R
	275	15	HS8	R	CR 240×275×15 HS8 R
	280	20	HS7	R	CR 240×280×20 HS7 R
250	280	15	HS8	R	CR 250×280×15 HS8 R
	290	15,88	HS8	R	CR 250×290×16 HS8 R
260	290	16	HS8	R	CR 260×290×16 HS8 R
	300	20	HS8	R	CR 260×300×20 HS8 R
	304	20	HS8	R	CR 260×304×20 HS8 R
265	310	22	HS7	R	CR 265×310×22 HS7 R

Dimensions			Design	Lip material	Designation
Shaft diameter d_1	Bore diameter D	Bore depth B			
mm			–	–	–
266	310	20	HS8	R	CR 266x310x20 HS8 R
270	310	20	HS8	R	CR 270x310x20 HS8 R
280	310	15	HS8	R	CR 280x310x15 HS8 R
	310	16	HS8	R	CR 280x310x16 HS8 R
	320	19,05	HS8	R	CR 280x320x19 HS8 R
	324	20	HS8	R	CR 280x324x20 HS8 R
	325	22	HS8	H	CR 280x325x22 HS8 H
290	330	20	HS8	R	CR 290x330x20 HS8 R
	335	24	HS7	R	CR 290x335x24 HS7 R
300	340	20	HS8	R	CR 300x340x20 HS8 R
	345	22	HS7	R	CR 300x345x22 HS7 R
310	340	15	HS8	V	CR 310x340x15 HS8 V
	340	15	HS8	R	CR 310x340x15 HS8 R
	350	20	HS8	D	CR 310x350x20 HS8 D
320	360	20	HS8	R	CR 320x360x20 HS8 R
	368,10	19,05	HS6	R	CR 320x368x19 HS6 R
330	380	22	HS8	H	CR 330x380x22 HS8 H
340	372	18	HS8	R	CR 340x372x18 HS8 R
	380	20	HS8	R	CR 340x380x20 HS8 R
345	390	25	HS8	R	CR 345x390x25 HS8 R
350	390	18	HS8	R	CR 350x390x18 HS8 R
355	393	20	HS8	R	CR 355x393x20 HS8 R
360	400	18	HS8	R	CR 360x400x18 HS8 R
	405	25	HS8	H	CR 360x405x25 HS8 H
	410,80	22,26	HS8	R	CR 360x411x22 HS8 R
380	418	19	HS7	R	CR 380x418x19 HS7 R
	418	19	HS8	R	CR 380x418x19 HS8 R
	420	19,05	HS8	V	CR 380x420x19 HS8 V
	420	20	HS8	D	CR 380x420x20 HS8 D
	420	20	HS7	R	CR 380x420x20 HS7 R
	420	20	HS8	H	CR 380x420x20 HS8 H
	420	20	HS8	D	CR 380x420x20 HS8 D
	430	20	HS8	R	CR 380x430x20 HS8 R
400	440	20	HS7	R	CR 400x440x20 HS7 R
	444	13,50	HS8	R	CR 400x444x14 HS8 R
	450	25	HS8	R	CR 400x450x25 HS8 R
	451	22,23	HS8	R	CR 400x451x22 HS8 R
410	454	19	HS8	R	CR 410x454x19 HS8 R
420	460	20	HS7	R	CR 420x460x20 HS7 R
430	480	22	HS8	R	CR 430x480x22 HS8 R
440	480	20	HS8	R	CR 440x480x20 HS8 R
	480	21	HS8	H	CR 440x480x21 HS8 H
450	500	25	HS8	R	CR 450x500x25 HS8 R
452	503	20,65	HS8	R	CR 452x503x21 HS8 R
460	510	22	HS8	R	CR 460x510x22 HS8 R

Radial shaft seals – HS6, HS7 and HS8 – metric dimensions

d_1 480 – 3 000 mm

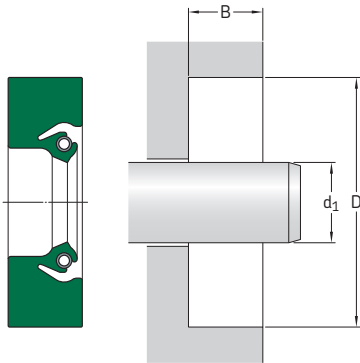

The table includes only a selection of available sizes. Contact your SKF sales representative for more information.

Please see **pages 74 to 76** for housing bore requirements.

Dimensions		Bore depth B	Design	Lip material	Designation
Shaft diameter d_1	Bore diameter D				
mm			–	–	–
480	530	20	HS8	R	CR 480×530×20 HS8 R
490	530	20	HS8	R	CR 490×530×20 HS8 R
	540	25	HS8	R	CR 490×540×25 HS8 R
	541	20,70	HS6	R	CR 490×541×21 HS6 R
500	550	25	HS8	R	CR 500×550×25 HS8 R
510	548	24,50	HS8	R	CR 510×548×25 HS8 R
515	555	20	HS8	R	CR 515×555×20 HS8 R
519	560	25	HS8	D	CR 519×560×25 HS8 D
530	576	21	HS8	R	CR 530×576×21 HS8 R
	580	20	HS8	R	CR 530×580×20 HS8 R
	580	22	HS8	R	CR 530×580×22 HS8 R
	580	25	HS8	R	CR 530×580×25 HS8 R
550	590	20	HS8	R	CR 550×590×20 HS8 R
556	610	25,40	HS7	R	CR 556×610×25 HS7 R
560	604	20	HS8	R	CR 560×604×20 HS8 R
590	640	25	HS8	R	CR 590×640×25 HS8 R
600	640	20	HS8	R	CR 600×640×20 HS8 R
615	665	24	HS8	R	CR 615×665×24 HS8 R
620	670	22	HS8	D	CR 620×670×22 HS8 D
625	676	19	HS8	D	CR 625×676×19 HS8 D
630	670	20	HS8	R	CR 630×670×20 HS8 R
650	700	20	HS8	R	CR 650×700×20 HS8 R
690	730	20	HS8	R	CR 690×730×20 HS8 R

Dimensions			Design	Lip material	Designation
Shaft diameter d_1	Bore diameter D	Bore depth B			
mm			–	–	–
700	750	20	HS8	R	CR 700×750×20 HS8 R
	765	25	HS8	R	CR 700×765×25 HS8 R
720	771,10	21	HS8	D	CR 720×771×21 HS8 D
737	790	15,88	HS6	R	CR 737×790×16 HS6 R
740	790	15,88	HS8	R	CR 740×790×16 HS8 R
	790	25	HS8	R	CR 740×790×25 HS8 R
760	800	20,60	HS8	R	CR 760×800×21 HS8 R
	810	20,60	HS8	R	CR 760×810×21 HS8 R
	820	17,50	HS8	R	CR 760×820×18 HS8 R
780	820	18	HS8	R	CR 780×820×18 HS8 R
800	850	25,40	HS8	R	CR 800×850×25 HS8 R
810	860	20,65	HS7	R	CR 810×860×21 HS7 R
840	892	18	HS6	R	CR 840×892×18 HS6 R
850	900	22	HS8	R	CR 850×900×22 HS8 R
865	911	18	HS8	R	CR 865×911×18 HS8 R
867	920	15,88	HS6	R	CR 867×920×16 HS6 R
870	920	15,88	HS8	R	CR 870×920×16 HS8 R
910	966	17,86	HS6	R	CR 910×966×18 HS6 R
925	975	22	HS8	D	CR 925×975×22 HS8 D
930	982	22,23	HS6	R	CR 930×982×22 HS6 R
1 055	1 100	25	HS8	D	CR 1055×1100×25 HS8 D
1 070	1 120	20	HS6	R	CR 1070×1120×20 HS6 R
1 105	1 151	17,50	HS8	R	CR 1105×1151×18 HS8 R
1 180	1 230	20	HS6	R	CR 1180×1230×20 HS6 R
1 248	1 298	20,70	HS8	R	CR 1248×1298×21 HS8 R
1 370	1 420	19,83	HS8	H	CR 1370×1420×20 HS8 H
1 380	1 420	18	HS8	R	CR 1380×1420×18 HS8 R
	1 725	20	HS8	R	CR 1675×1725×20 HS8 R
1 675	1 725	20,62	HS8	D	CR 1675×1725×21 HS8 D
	1 860	20	HS8	R	CR 1810×1860×20 HS8 R
1 810	1 860	20,62	HS8	D	CR 1810×1860×21 HS8 D
	2 900	20,63	HS8	D	CR 2850×2900×21 HS8 D
2 850	2 900	20,63	HS8	D	CR 2850×2900×21 HS8 D
2 900	2 959	17,33	HS6	R	CR 2900×2959×17 HS6 R
3 000	3 050	20,63	HS8	D	CR 3000×3050×21 HS8 D

Radial shaft seals – HS6, HS7 and HS8 – inch dimensions

d_1 5.500 – 10.250 in.

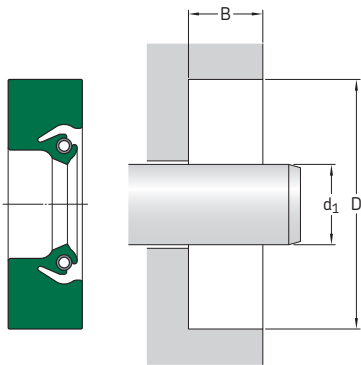

The table includes only a selection of available sizes. Contact your SKF sales representative for more information.

Please see pages 74 to 76 for housing bore requirements.

Dimensions			Design	Lip material	Designation
Shaft diameter d_1	Bore diameter D	Bore depth B			
in./mm			–	–	–
5.500 139,70	6.500 165,10	0.500 12,70	HS8	V	CR 597548
6.000 152,40	7.250	0.625	HS8	R	CR 592986
	184,15	15,88	HS8	R	CR 60037
	7.500	0.535			
	190,50	13,59			
6.300 160,00	7.874	0.596	HS8	D	CR 595052
	200,00	15,14			
6.438 163,53	7.688	0.625	HS7	R	CR 594760
	195,28	15,88			
7.000 177,80	8.000	0.500	HS8	D	CR 70008
	203,20	12,70			
7.250 184,15	8.250	0.500	HS8	R	CR 595012
	209,55	12,70	HS7	R	CR 528377
	8.250	0.500			
	209,55	12,70			
7.625 193,68	8.875	0.625	HS8	R	CR 595207
	225,43	15,88			
7.750 196,85	8.750	0.500	HS8	R	CR 529601
	222,25	12,70			
8.000 203,20	9.000	0.625	HS8	V	CR 594935
	228,60	15,88	HS8	R	CR 592376
	9.250	0.625			
	234,95	15,88	HS7	R	CR 590326
	10.000	0.750			
	254,00	19,05			
8.250 209,55	9.500	0.625	HS7	R	CR 592180
	241,30	15,88			
		10.250	0.750	HS7	R
	260,35	19,05			

Dimensions			Design	Lip material	Designation
Shaft diameter d_1	Bore diameter D	Bore depth B			
in./mm			–	–	–
8.500	9.500	0.500	HS8	V	CR 594745
215,90	241,30	12,70			
	10.000	0.625	HS8	R	CR 594318
	254,00	15,88			
8.750	9.750	0.500	HS8	V	CR 87440
222,25	247,65	12,70			
	10.000	0.625	HS8	R	CR 592627
	254,00	15,88			
	10.750	0.750	HS7	R	CR 597553
	273,05	19,05			
8.938	9.938	0.625	HS7	R	CR 595004
227,03	254,43	15,88			
9.000	10.250	0.625	HS7	R	CR 592581
228,60	260,35	15,88			
	10.500	0.750	HS8	R	CR 592600
	266,70	19,05			
	10.674	0.703	HS8	R	CR 592779
	271,12	17,86			
9.250	11.250	0.625	HS7	R	CR 593625
234,95	285,75	15,88			
	11.250	0.750	HS8	R	CR 592858
	285,75	19,05			
9.438	10.688	0.625	HS7	R	CR 592126
239,73	271,48	15,88			
9.500	11.000	0.625	HS8	R	CR 531331
241,30	279,40	15,88			
	11.500	0.625	HS8	R	CR 597507
	292,10	15,88			
9.750	10.750	0.500	HS7	R	CR 592988
247,65	273,05	12,70			
	11.250	0.625	HS7	R	CR 593385
	285,75	15,88			
9.938	11.188	0.625	HS8	R	CR 594753
252,43	284,18	15,88			
	11.438	0.750	HS8	R	CR 592731
	290,53	19,05			
10.000	11.000	0.562	HS8	R	CR 1000018
254,00	279,40	14,28			
	11.250	0.625	HS7	R	CR 1000117
	285,75	15,88			
	11.500	0.750	HS7	R	CR 1000257
	292,10	19,05			
	12.000	0.625	HS7	R	CR 1000527
	304,80	15,88			
	12.000	0.625	HS7	V	CR 1000025
	304,80	15,88			
10.125	11.750	0.750	HS8	R	CR 1012338
257,18	298,45	19,05			
10.188	11.188	0.500	HS7	R	CR 1019017
258,78	284,18	12,70			
10.250	11.250	0.625	HS7	R	CR 1025017
260,35	285,75	15,88			
	12.000	0.625	HS8	R	CR 1025368
	304,80	15,88			

Radial shaft seals – HS6, HS7 and HS8 – inch dimensions

d_1 10.438 – 14.000 in.

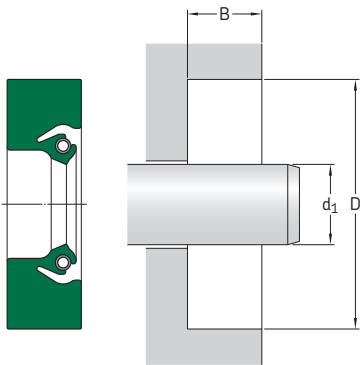

The table includes only a selection of available sizes. Contact your SKF sales representative for more information.

Please see pages 74 to 76 for housing bore requirements.

Dimensions		Bore depth B	Design	Lip material	Designation
Shaft diameter d_1	Bore diameter D				
in./mm					
10.438 265,13	11.688 296,88	0.875 22,23	HS8	R	CR 1043148
10.500 266,70	11.500 292,10	0.500 12,70	HS8	R	CR 1050018
	12.000 304,80	0.750 19,05	HS8	R	CR 1050258
	12.000 304,80	0.750 19,05	HS7	R	CR 1050257
10.710 272,03	12.511 317,78	0.625 15,88	HS8	R	CR 1071448
10.875 276,23	12.875 327,03	0.578 14,68	HS6	R	CR 527099
11.000 279,40	12.000 304,80	0.625 15,88	HS7	R	CR 1100027
	12.500 317,50	0.750 19,05	HS8	R	CR 1100258
	12.500 317,50	0.750 19,05	HS7	R	CR 1100257
	13.000 330,20	0.750 19,05	HS8	R	CR 1100538
11.125 282,58	12.375 314,33	0.625 15,88	HS8	R	CR 1113118
11.250 285,75	12.750 323,85	0.750 19,05	HS7	R	CR 1125257
11.375 288,93	12.375 314,33	0.500 12,70	HS7	R	CR 1138017
11.422 290,12	12.922 328,22	0.750 19,05	HS7	R	CR 1142257
11.500 292,10	12.500 317,50	0.500 12,70	HS8	R	CR 1150018
	13.000 330,20	0.750 19,05	HS8	R	CR 1150258

Dimensions			Design	Lip material	Designation
Shaft diameter d_1	Bore diameter D	Bore depth B			
in./mm			–	–	–
11.750 298,45	13.250 336,55	0.750 19,05	HS7	R	CR 1175257
11.875 301,63	13.125 333,38	0.625 15,88	HS8	R	CR 1188118
12.000 304,80	13.000 330,20	0.500 12,70	HS8	D	CR 1200028
	13.500	0.750	HS8	R	CR 1200258
	342,90	19,05			
	14.000	0.813	HS8	R	CR 1200558
355,60	20,65				
12.375 314,33	13.875 352,43	0.750 19,05	HS7	R	CR 1238257
12.500 317,50	13.500	0.500	HS8	R	CR 1250018
	342,90	12,70			
	14.000	0.750	HS7	R	CR 1250257
355,60	19,05				
12.625 320,68	14.125 358,78	0.750 19,05	HS7	R	CR 1263237
12.750 323,85	14.250	0.625	HS8	R	CR 1275238
	361,95	15,88			
	14.250	0.750	HS7	R	CR 1275257
361,95	19,05				
13.000 330,20	14.500	0.625	HS7	R	CR 1300237
	368,30	15,88			
	14.500	0.750	HS8	R	CR 1300258
	368,30	19,05			
15.000	0.750	HS8	R	CR 1300548	
381,00	19,05				
13.125 333,38	15.125 384,18	0.750 19,05	HS8	R	CR 592920
13.250 336,55	14.750 374,65	0.625 15,88	HS7	R	CR 1325237
13.375 339,73	14.875 377,83	0.625 15,88	HS8	R	CR 594057
13.500 342,90	15.000	0.750	HS8	R	CR 1350258
	381,00	19,05			
	15.500	0.625	HS7	R	CR 1350527
393,70	15,88				
13.750 349,25	15.250 387,35	0.750 19,05	HS7	R	CR 1375257
13.875 352,43	15.375 390,53	0.750 19,05	HS7	R	CR 1388257
14.000 355,60	15.000	0.500	HS8	R	CR 1400018
	381,00	12,70			
	15.500	0.750	HS8	R	CR 1400258
	393,70	19,05			
	15.500	0.750	HS7	R	CR 1400257
	393,70	19,05			
	15.500	0.750	HS8	V	CR 594261
	393,70	19,05			
	16.000	0.813	HS7	R	CR 1400557
406,40	20,65				
16.000	1.000	HS8	R	CR 1400588	
406,40	25,40				

Radial shaft seals – HS6, HS7 and HS8 – inch dimensions

d_1 14.250 – 20.000 in.

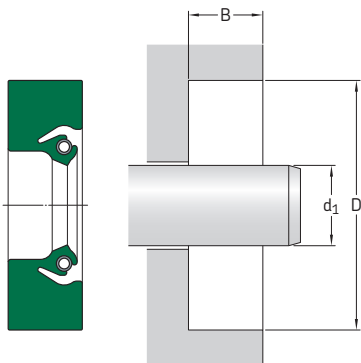

The table includes only a selection of available sizes. Contact your SKF sales representative for more information.

Please see **pages 74 to 76** for housing bore requirements.

Dimensions		Bore diameter D	Bore depth B	Design	Lip material	Designation
Shaft diameter d_1						
in./mm						
14.250 361,95	16.250 412,75	1.000 25,40	HS7	R		CR 1425587
14.500 368,30	15.500 393,70	0.500 12,70	HS8	R		CR 1450018
14.625 371,48	16.125 409,58	0.750 19,05	HS7	R		CR 1463257
15.000 381,00	16.500 419,10	0.750 19,05	HS7	R		CR 1500257
	17.000 431,80	0.813 20,65	HS8	R		CR 1500558
15.250 387,35	16.625 422,28	0.500 12,70	HS8	R		CR 1525158
	16.750 425,45	0.750 19,05	HS7	R		CR 1525257
15.500 393,70	17.000 431,80	0.750 19,05	HS7	R		CR 1550257
	17.500 444,50	0.813 20,65	HS7	R		CR 1550557
15.750 400,05	17.250 438,15	0.685 19,05	HS8	R		CR 1575248
	16.000 406,40	17.000 431,80	0.500 12,70	HS8	R	
17.000 431,80		0.500 12,70	HS8	D		CR 1600019
17.500 444,50		0.750 19,05	HS8	R		CR 1600258
18.000 457,20		0.750 19,05	HS8	R		CR 1600578
18.000 457,20		0.813 20,65	HS8	R		CR 1600558
16.500 419,10		17.500 444,50	0.500 12,70	HS7	R	
	18.500 469,90	0.813 20,65	HS7	R		CR 1650557

Dimensions			Design	Lip material	Designation
Shaft diameter d_1	Bore diameter D	Bore depth B			
in./mm			-	-	-
16.750 425,45	18.250 463,55	0.750 19,05	HS7	R	CR 1675257
16.875 428,63	18.375 466,73	0.500 12,70	HS7	R	CR 1688217
17.500 444,50	19.500 495,30	1.000 25,40	HS7	R	CR 1750587
17.716 449,99	19.716 500,79	0.813 20,65	HS7	R	CR 1771557
17.750 450,85	19.750 501,65	0.813 20,65	HS7	R	CR 1775557
18.000 457,20	19.000 482,60	0.500 12,70	HS8	R	CR 1800018
	19.500 495,30	0.750 19,05	HS7	R	CR 1800257
	20.000 508,00	0.813 20,65	HS8	R	CR 1800558
18.250 463,55	19.750 501,65	0.750 19,05	HS7	R	CR 1825257
	20.250 514,35	0.813 20,65	HS7	R	CR 1825557
18.375 466,73	20.375 517,53	0.813 20,65	HS8	R	CR 1838558
	20.500 520,70	0.875 22,23	HS8	R	CR 1837608
18.500 469,90	20.000 508,00	0.750 19,05	HS8	D	CR 1850248
	20.500 520,70	1.000 25,40	HS7	R	CR 1850587
18.750 476,25	20.250 514,35	0.750 19,05	HS7	R	CR 1875257
18.937 481,00	20.937 531,80	0.813 20,65	HS7	R	CR 1894557
19.000 482,60	20.500 520,70	0.750 19,05	HS8	R	CR 1900258
	21.000 533,40	0.813 20,65	HS7	R	CR 1900557
19.500 495,30	21.500 546,10	0.813 20,65	HS7	R	CR 1950557
	21.500 546,10	0.813 20,65	HS8	R	CR 1950518
19.750 501,65	21.750 552,45	0.625 15,88	HS8	R	CR 1975528
20.000 508,00	21.500 546,10	0.625 15,88	HS8	R	CR 2000238
	21.500 546,10	0.750 19,05	HS8	R	CR 2000258
	22.000 558,80	0.625 15,88	HS7	R	CR 2000527
	22.000 558,80	1.000 25,40	HS7	R	CR 2000587
	22.125 561,98	0.916 23,27	HS8	R	CR 2000648
	22.125 561,98	0.916 23,27	HS8	D	CR 2000649

Radial shaft seals – HS6, HS7 and HS8 – inch dimensions

d_1 20.500 – 33.125 in.

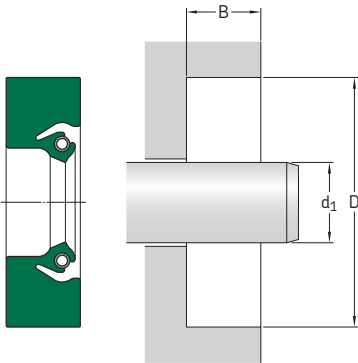

The table includes only a selection of available sizes. Contact your SKF sales representative for more information.

Please see pages 74 to 76 for housing bore requirements.

Dimensions		Bore diameter D	Bore depth B	Design	Lip material	Designation
Shaft diameter d_1						
in./mm						
20.500 520,70	22.500 571,50	0.875 22,23	HS8	R		CR 2050568
20.625 523,88	22.625 574,68	0.813 20,65	HS7	R		CR 2063557
21.000 533,40	22.580 573,53	0.578 14,68	HS8	R		CR 2100228
	23.000 584,20	0.750 19,05	HS8	R		CR 2100518
	23.000 584,20	0.813 20,65	HS8	V		CR 594201
	23.000 584,20	0.813 20,65	HS7	R		CR 2100557
22.000 558,80	23.500 596,90	0.750 19,05	HS7	R		CR 2200257
	23.500 596,90	0.750 19,05	HS8	R		CR 2200218
	24.000 609,60	0.813 20,65	HS8	V		CR 2200555
	24.000 609,60	0.813 20,65	HS8	D		CR 2200558
	24.000 609,60	0.813 20,65	HS7	R		CR 2200557
22.250 565,15	24.250 615,95	0.813 20,65	HS7	R		CR 2225557
22.500 571,50	24.500 622,30	0.813 20,65	HS7	R		CR 2250557
22.638 575,00	24.638 625,80	0.750 19,00	HS8	D		CR 2263548
22.750 577,85	24.750 628,65	0.813 20,65	HS7	R		CR 2275557
22.875 581,03	24.875 631,83	0.813 20,65	HS7	R		CR 2288557

Dimensions			Design	Lip material	Designation
Shaft diameter d_1	Bore diameter D	Bore depth B			
in./mm			–	–	–
23.000 584,20	25.000 635,00	0.813 20,65	HS8	R	CR 2300558
	25.000 635,00	0.813 20,65	HS8	D	CR 2300559
23.208 589,48	25.208 640,28	0.813 20,65	HS8	R	CR 2320558
23.750 603,25	25.750 654,05	0.813 20,65	HS8	R	CR 2575558
24.000 609,60	25.500 647,70	0.750 19,05	HS8	R	CR 2400258
	25.500 647,70	0.750 19,05	HS7	R	CR 2400257
	26.000 660,40	1.000 25,40	HS8	D	CR 2400598
24.500 622,30	26.000 660,40	0.750 19,05	HS7	R	CR 2450257
25.000 635,00	26.500 673,10	0.750 19,05	HS7	D	CR 2500247
	27.000 685,80	0.813 20,65	HS7	R	CR 2500557
26.000 660,40	28.125 714,38	0.916 23,27	HS8	R	CR 2600648
26.375 669,93	27.627 701,73	0.625 15,88	HS8	R	CR 2637118
27.000 685,80	29.000 736,60	0.813 20,65	HS8	R	CR 2700558
27.500 698,50	28.750 730,25	0.625 15,88	HS7	R	CR 2750117
28.000 711,20	30.000 762,00	0.813 20,65	HS8	R	CR 2800558
28.875 733,43	30.875 784,23	0.813 20,65	HS7	R	CR 2888557
29.000 736,60	31.000 787,40	0.813 20,65	HS7	V	CR 2900556
29.750 755,65	31.750 806,45	0.813 20,65	HS8	R	CR 2975558
30.000 762,00	31.250 793,75	0.625 15,88	HS8	R	CR 3000118
	32.000 812,80	1.000 25,40	HS8	H	CR 3000519
30.750 781,05	31.750 806,45	0.500 12,70	HS7	R	CR 3075017
32.375 822,33	34.375 873,13	1.000 25,40	HS8	H	CR 3237519
32.500 825,50	34.500 876,30	0.916 23,27	HS7	R	CR 3250577
33.125 841,38	35.125 892,18	0.813 20,65	HS8	R	CR 3312558

Radial shaft seals – HS6, HS7 and HS8 – inch dimensions

d_1 34.500 – 171.900 in.

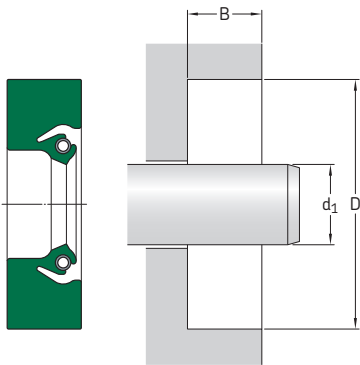

The table includes only a selection of available sizes. Contact your SKF sales representative for more information.

Please see pages 74 to 76 for housing bore requirements.

Dimensions		Bore diameter D	Bore depth B	Design	Lip material	Designation
Shaft diameter d_1						
in./mm						
34.500 876,30	36.500 927,10	0.813 20,65	HS7	R	CR 3450557	
38.000 965,20	40.000 1 016,00	0.813 20,65	HS7	R	CR 3800557	
38.500 977,90	40.500 1 028,70	0.813 20,65	HS7	R	CR 3850557	
40.250 1 022,35	41.750 1 060,45	0.750 19,05	HS8	R	CR 4025258	
48.000 1 219,20	50.000 1 270,00	0.813 20,65	HS8	R	CR 4800518	
51.000 1 295,40	53.000 1 346,20	0.813 20,65	HS8	R	CR 5100558	
53.000 1 346,20	54.875 1 393,83	0.813 20,65	HS8	R	CR 5300488	
54.000 1 371,60	56.000 1 422,40	0.813 20,65	HS7	R	CR 5400557	
58.500 1 485,90	60.500 1 536,70	0.813 20,65	HS8	R	CR 5850518	
60.250 1 530,35	62.313 1 582,75	0.750 19,05	HS8	R	CR 531572	
62.598 1 589,99	64.598 1 640,79	0.813 20,65	HS7	R	CR 6259557	
69.000 1 752,60	71.000 1 803,40	0.813 20,65	HS8	R	CR 6900558	
72.500 1 841,50	74.500 1 892,30	0.813 20,65	HS8	R	CR 7250558	
75.000 1 905,00	77.000 1 955,80	0.815 20,70	HS8	R	CR 7500518	

Dimensions			Design	Lip material	Designation
Shaft diameter d_1	Bore diameter D	Bore depth B			
in./mm			–	–	–
76.000 <i>1 930,40</i>	78.000 <i>1 981,20</i>	0.813 <i>20,65</i>	HS8	R	CR 594316
81.000 <i>2 057,40</i>	83.000 <i>2 108,20</i>	0.813 <i>20,65</i>	HS8	R	CR 8100558
87.750 <i>2 228,85</i>	89.750 <i>2 279,65</i>	0.813 <i>20,65</i>	HS8	R	CR 8775558
94.750 <i>2 406,65</i>	97.000 <i>2 463,80</i>	0.688 <i>17,48</i>	HS8	R	CR 9475658
98.625 <i>2 505,08</i>	100.625 <i>2 555,88</i>	0.813 <i>20,65</i>	HS8	R	CR 9862568
106.000 <i>2 692,40</i>	107.000 <i>2 717,80</i>	0.500 <i>12,70</i>	HS8	R	CR 594926
125.000 <i>3 175,00</i>	126.250 <i>3 206,75</i>	0.625 <i>15,88</i>	HS8	R	CR 595208
171.900 <i>4 366,26</i>	173.876 <i>4 416,45</i>	0.813 <i>20,65</i>	HS8	R	CR 595214



Cassette seals

General	326
Design features	327
Testing	327
Installation	327
SKF Mudblock seal designs MUD5 and MUD7	328

Cassette seals

General

The design of SKF Mudblock cassette seals has been optimized to provide excellent retention of either grease or oil and maximum protection against liquid or solid contaminants (→ **fig. 1**). The seals are made to order to meet the demands of each specific application.

SKF Mudblock seals are widely used in wheel-end applications such as the front and rear axles of, for example:

- tractors
- agricultural machinery
- construction equipment
- forestry equipment
- off-highway trucks

Fig. 1

SKF Mudblock designs for oil lubricated applications

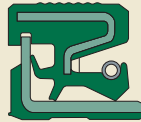

MUD1



MUD2

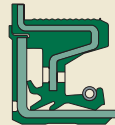

MUD4

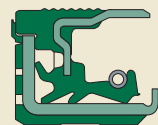

MUD5

SKF Mudblock designs for grease lubricated applications

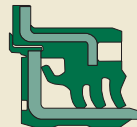

MUD3



MUD6

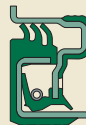

MUD7

Design features

All SKF Mudblock seals are designed with an integrated wear sleeve and a rubber inside diameter, but can have any one of a number of sealing lip and auxiliary lip configurations. The elastomeric material is normally nitrile rubber, but the seals are also available in other compounds including fluoro rubber, hydrogenated nitrile rubber or polyacrylate to meet the demands of different operating conditions. For more information, please refer to paragraph *Sealing lip materials*, starting on **page 30**.

Testing

SKF conducts tests in climatic cells of the SKF Mudblock seals at global testing facilities in USA, Europe and Asia. The tests include both our own tests and tests according to customer specifications. SKF Mudblock seals are engineered using Finite Element Analysis (FEA) to obtain optimum design solutions. FEA evaluates:

- stress/strain behavior of the sealing lip in deformed condition
- lip contact forces
- lip opening pressure
- displacement of the lips
- assembly simulation of seal and sleeve

Installation

Proper installation of SKF Mudblock seals is important for optimal functioning of the seals. Please contact SKF for information and support regarding the design of installation tools for SKF Mudblock seals.

SKF Mudblock seal designs MUD5 and MUD7

SKF Mudblock seal designs MUD5 and MUD7 are a new generation of radial shaft sealing units, specifically developed for heavy-duty applications in harsh environments and tough operating conditions.

SKF Mudblock seals MUD5 (→ **fig. 2**) are designed for oil lubricated applications and provide features including:

- half metal/half rubber outside diameter for reliable seal retention in the bore as well as improved sealing performance
- spring-loaded main lip with SKF WAVE lip design for bi-directional pumping action
- axial and auxiliary radial lips for contaminant exclusion
- integrated wear sleeve, curled for a reliable unitized solution to facilitate installation and prevent damage to the lips during transportation, handling and installation.
- centrifugal flap for exclusion of contaminants
- bumper maintaining the relative position between the seal and the sleeve as well as acting as a barrier against contaminants
- rubber covered inside diameter for high sealing ability and easy installation

SKF Mudblock seals MUD7 (→ **fig. 3**) are designed for use in grease lubricated applications and provide features including:

- half metal/half rubber outside diameter for reliable seal retention in the bore as well as improved sealing performance
- rubber covered inside diameter for improved sealing performance and easy installation
- integrated wear sleeve
- SKF patented lip design for extended bearing service life
- bumper maintaining the relative position between the seal and the sleeve as well as acting as a barrier against contaminants
- auxiliary radial lips for contaminant exclusion

The SKF patented lip design has a special geometry combining both a spring-loaded radial lip and an axial lip. This design enables excess pressure inside the bearing chamber to pass the lip. Thus, the bearing can run cooler, resulting in extended service life.

Fig. 2

SKF Mudblock seal MUD5

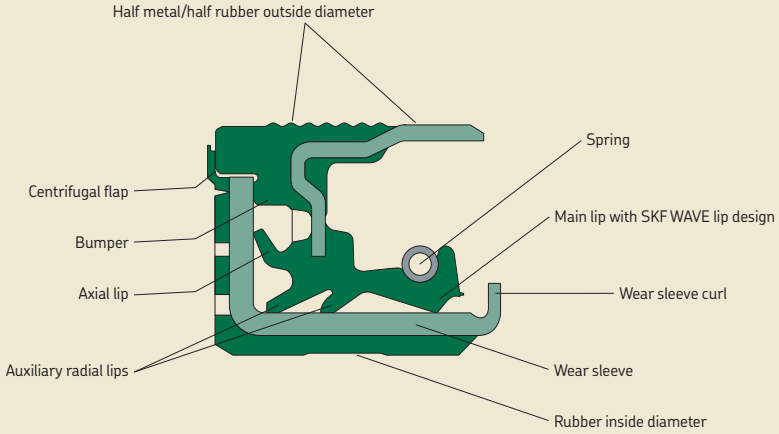

3

Fig. 3

SKF Mudblock seal MUD7

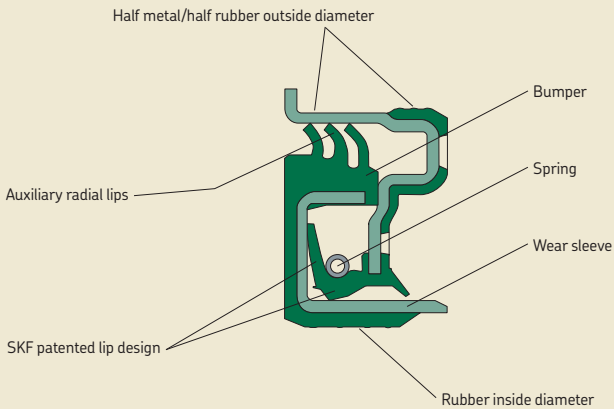



Wear sleeves

General	332
SKF SPEEDI-SLEEVE	333
Features	333
Size range	333
SKF SPEEDI-SLEEVE Gold	334
Choosing the right size	334
Installing SKF SPEEDI-SLEEVE	335
Removing SKF SPEEDI-SLEEVE	337
4.1 Product table: SKF SPEEDI-SLEEVE	338
Wear sleeves for heavy industrial applications (LDSL)	360
General	360
Designs and features	361
Using LDSLV designs	362
Installation	362
Removal	362
4.2 Product table: LDSLV3 and LDSLV4	364

Wear sleeves

General

To seal efficiently, radial shaft seals must run against a smooth, round counterface. If the counterface becomes worn, the seals will no longer be able to fulfil their function, which is to retain lubricant and exclude contaminants.

Typically, the counterface becomes scored when a contaminant particle is caught under the sealing lip and abrades a track as the shaft rotates. As this continues, the seal will enable more particles to pass or get stuck, and seal efficiency deteriorates, eventually leading to malfunction of the component that the seal is meant to protect. To rectify the situation, it is necessary to repair the shaft surface since a seal replacement will not be sufficient. To repair the shaft, it is usually necessary to disassemble the machine in order to either replace the shaft or grind down the counterface until it is again within specification.

SKF SPEEDI-SLEEVE (→ **fig. 1**) is a well-proven solution to overcome problems with

worn shafts without having to disassemble the shaft or changing the seal dimensions, while offering an excellent sealing surface. Now, SKF has developed a new generation SKF SPEEDI-SLEEVE with features providing an even further enhanced sealing system performance. Using SKF SPEEDI-SLEEVE, combined with an SKF radial shaft seal, customers will benefit from a more consistent and increased durability of the sealing system. This will enable a more stable maintenance planning with improved predictability of the system service life. SKF SPEEDI-SLEEVE is available for shaft diameters up to approximately 203 mm (8 in.). For larger shaft diameters, SKF offers wear sleeves for heavy industrial applications, LDSLV3 and LDSLV4 (→ **figs. 2 and 3**). See **page 360** for information regarding LDSLV designs.

Fig. 1

SKF SPEEDI-SLEEVE

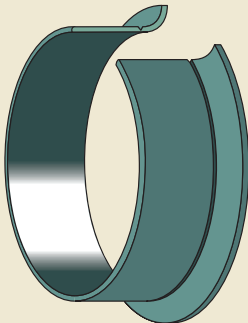
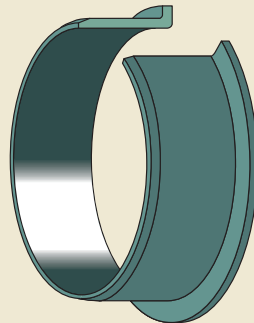

Fig. 2

LDSLV3 wear sleeve



SKF SPEEDI-SLEEVE

This thin-walled sleeve [0,28 mm (0.011 in.)], developed by SKF, is simply pushed in position over the worn area, providing a counterface surface that is optimized for radial shaft seals.

There is no shaft disassembly or machining involved and costly downtime is minimized. Since the same sized seal as the original can be used, there is no need to search for other seals, or keep a stock of different sizes.

No special equipment is required since the installation tool is supplied with the sleeve. A mallet and a pair of pliers are all that is needed for the installation.

Features

The new generation SKF SPEEDI-SLEEVE uses a proprietary stainless steel material and manufacturing process, resulting in an optimized seal counterface surface that minimizes wear on both sleeve and sealing lip. The proprietary material provides increased strength and excellent ductility properties of the sleeve. Imperceptible lubricant pockets enable the lubricant to reside on the sleeve and thereby prevent dry running of the sealing lip that otherwise can create excessive wear. The contact surface is wear resistant and machined to minimize directionality ($0^\circ \pm 0,05$) with a finish of R_a 0,25 to 0,5 μm (10 to 20 $\mu\text{in.}$). This is, in fact, a better counterface surface than can often be achieved on a shaft.

SKF SPEEDI-SLEEVE has a removable flange to simplify installation (\rightarrow fig. 4). The flange can

most often be left intact, but in applications where the flange will interfere with other system components, it should be removed so as not to cause friction heat and wear debris. The flange should also be removed in applications where it may reduce the supply of lubricant to the seal. This would reduce the cooling effect of the lubricant, resulting in elevated underlip temperatures and premature ageing of the seal material.

If the flange is to be removed, it should be cut from the outside diameter into the radius in one location prior to installation. The flange can then be twisted and raised up after installation and grasped with a pair of long-nosed pliers and twisted into a coil.

Size range

The standard size range covers sleeves for shaft diameters from 11,99 to 203,33 mm (0.472 to 8 in.). Depending on production quantities, non-standard sizes can be manufactured. Each sleeve is designed to fit a specific shaft diameter range, usually above and below the nominal shaft diameter. This permits some flexibility to accommodate variations in the actual shaft diameter.

4

Fig. 3

LDSL4 wear sleeve

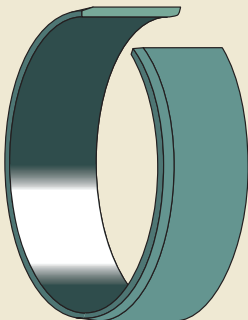
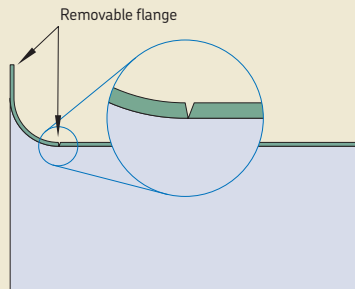

Fig. 4

SKF SPEEDI-SLEEVE removable flange



Wear sleeves

SKF SPEEDI-SLEEVE Gold

SKF SPEEDI-SLEEVE Gold is an enhanced version of standard SKF SPEEDI-SLEEVE, offering improved resistance to abrasive wear. Designed for applications where extended sealing system life is needed, SKF SPEEDI-SLEEVE Gold bridges the performance gap between the standard sleeve and expensive custom shaft treatments. A thin, metallic coating applied to the base stainless steel imparts a gold colour and significantly increases durability. SKF SPEEDI-SLEEVE Gold is particularly effective in environments where there are abrasive contaminants, especially when combined with a seal manufactured from the SKF fluoro rubber material, SKF Duralife.

The installation procedure is identical to that of standard SKF SPEEDI-SLEEVE and the original seal size can still be used.

Test results

SKF SPEEDI-SLEEVE Gold has been thoroughly tested to establish its level of abrasion resistance in severely contaminated environments using both coarse and fine sand. The tests were carried out at temperatures up to 110 °C (225 °F) and at shaft speeds up to 8,6 m/s (1 700 ft/min). Under these conditions, seals on SKF SPEEDI-SLEEVE Gold ran for an average of 2 500 hours.

In other tests, it was found that continuous salt spray at 35 °C (95 °F) produced no trace of corrosion even after 600 hours.

Size range and availability

SKF SPEEDI-SLEEVE Gold is available in the same sizes as standard SKF SPEEDI-SLEEVE.

Choosing the right size

To determine the appropriate sleeve size, it is first necessary to clean the shaft carefully. The diameter of an undamaged section of the seal counterface should then be measured on at least three different planes. The arithmetical mean of these measurements determines the size of SKF SPEEDI-SLEEVE. If the value lies within the permissible range listed in the product table for the shaft diameter d_1 , SKF SPEEDI-SLEEVE will have an adequate tight fit on the shaft and will not require an adhesive.

If no suitable size is listed in the product table, it will be necessary to rework the shaft to an appropriate dimension. This also means that a new seal size will be required. If production quantities are sufficient enough, SKF can provide specially dimensioned SKF SPEEDI-SLEEVE or other wear sleeve solution.

Installing SKF SPEEDI-SLEEVE

Although installation is simple, it should be done carefully to achieve the best results. As the thin-walled sleeve has an interference fit, any disturbances on the shaft surface may create a similar pattern on the sleeve surface and cause the seal to leak. Therefore, the seal counterface surface of the shaft should be carefully cleaned and any burrs or rough spots filed down prior to installation. Deep wear grooves, scratches or very rough surfaces should be treated with a suitable powdered metal epoxy-type filler. The sleeve must be positioned on the shaft before the filler has hardened.

SKF SPEEDI-SLEEVE must not be installed over keyways, cross holes, splines or threads since this will result in deformation of the sleeve, making it difficult for the seal to follow its new counterface surface as it rotates.

SKF SPEEDI-SLEEVE should never be heated prior to installation. Using heat will cause the sleeve to expand, but when it cools, it may not contract back to its original size, resulting in a loose fit on the shaft.

See **fig. 5** for different SKF SPEEDI-SLEEVE installations.

SKF SPEEDI-SLEEVE installations

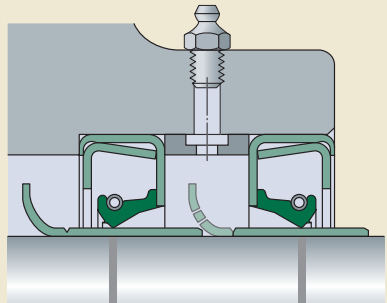
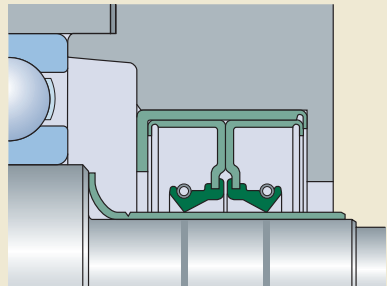
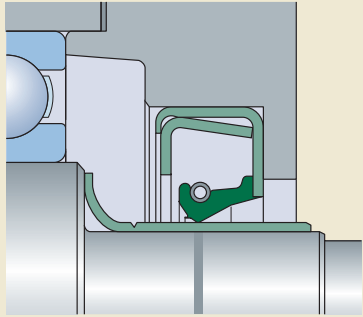

Fig. 6

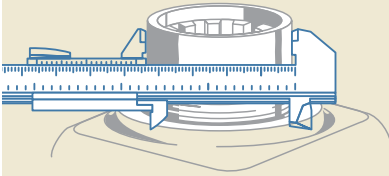

Fig. 7

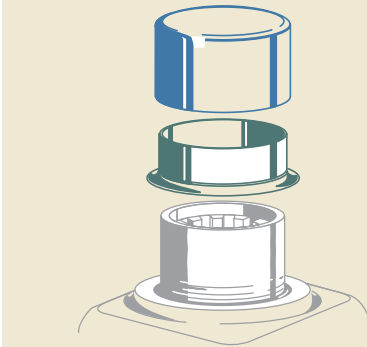
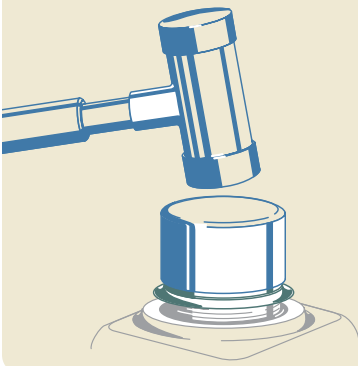

Fig. 8



Installation procedure

- 1 Clean the seal counterface surface on the shaft. File down any burrs or rough spots and make sure that the sleeve will not be installed over keyways, cross holes, splines or similar.
- 2 Measure the diameter on an unworn portion of the shaft where the sleeve will be positioned (→ fig. 6). Measure in three positions and average the readings to make sure the shaft is within recommended specifications. If the average diameter is within the range for a given sleeve size, there is sufficient press fit built into the sleeve to prevent it from sliding or spinning without using an adhesive.
- 3 Determine where the sleeve must be positioned to cover the worn area. Measure to the exact point, or mark directly on the surface. The sleeve must be placed over the worn area, not just bottomed or left flush with the end of the shaft.
- 4 Shallow wear grooves do not require filling. Optionally, a light layer of a non-hardening sealant can be applied to the inside diameter surface of the sleeve. Clean away sealant that migrates to the shaft or sleeve outside diameter surface.
- 5 If the shaft is deeply scored, fill the groove with a powdered metal epoxy-type filler. Install the sleeve before the filler hardens, enabling the sleeve to wipe off any excess filler. Clean away any remaining filler from the sleeve outside diameter surface.
- 6 It should be repeated that heat should never be used to install SKF SPEEDI-SLEEVE.
- 7 If the flange should be removed after installation, cut it from the outside diameter into the radius in one location. The flange end of the sleeve goes on the shaft first. Then, place the installation tool over the sleeve (→ fig. 7).
- 8 Gently tap the centre of the installation tool until the sleeve covers the worn shaft surface (→ fig. 8). If the installation tool is too short, a length of pipe or tubing with a squared-off, burr-free end can be used. Be sure that the inside diameter of the pipe is the same as that of the installation tool. Use care not to scratch the precision ground sleeve's outside diameter.

- 9 SKF SPEEDI-SLEEVE should always be installed so that the outside edge of the sleeve is seated on the full shaft diameter. It must not rest in or outside the chamfer area since the sharp edge will likely cut the sealing lip during seal installation.
- 10 If the flange was cut for removal, use a pair of long-nosed pliers to grasp the flange away from the sleeve and twist it into a coil, being careful not to lift the end of the sleeve off the shaft or it will leave a jagged edge. Flange removal must be done with care to avoid damage to the outside diameter of the sleeve.
- 11 After the sleeve is installed, check again for burrs that could damage the seal.
- 12 Lubricate the sleeve with the system medium before installing the seal.
- 13 Proceed with seal installation.

Removing SKF SPEEDI-SLEEVE

SKF SPEEDI-SLEEVE can be removed by applying heat to the sleeve with an electric heat blower, which will expand it enough to let it slide off the shaft without causing any damage to the shaft.

Alternatively, the sleeve can be removed in any of the following ways, always using care not to damage the shaft surface:

- by relieving the press-fit tension using a small hammer to peen across the full width of the sleeve
- by using a cold chisel to cut through the sleeve
- by using a pair of wire cutters starting at or near the flange and applying a twisting motion

Please note that SKF SPEEDI-SLEEVE cannot be reused.

SKF SPEEDI-SLEEVE – metric (converted from inch dimensions)

d_1 11,99 – 35,99 mm

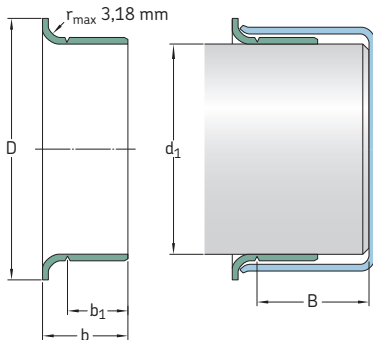

Shaft diameter range		Nominal dimensions					Designation
d_1 min	max	d_1	D $\pm 1,6$	b_1 $\pm 0,8$	b $\pm 0,8$	B^1	
mm		mm					–
11,99	12,07	11,99	15,49	5,99	8,41	47,63	CR 99049
12,65	12,75	12,70	15,49	6,35	8,74	50,80	CR 99050
13,89	14,00	14,00	19,05	6,35	9,93	46,51	CR 99055
14,22	14,38	14,30	19,05	6,35	9,93	46,51	CR 99056
14,96	15,06	15,01	19,05	5,00	8,99	47,29	CR 99059
15,82	15,93	15,88 15,88	19,05 19,05	7,95 7,95	10,31 10,31	50,80 50,80	CR 99810 ²⁾ CR 99062
15,90	16,00	16,00	18,24	7,95	11,13	50,80	CR 99058
16,94	17,04	16,99	22,23	8,00	11,00	50,80	CR 99068
17,32	17,42	17,37	22,86	7,95	11,13	50,80	CR 99060
17,88	18,01	18,01	24,43	8,00	11,00	46,00	CR 99082
19,00	19,10	19,05 19,05	24,00 24,00	7,95 7,95	11,13 11,13	50,80 50,80	CR 99811 ²⁾ CR 99076
19,28	19,33	19,30	23,83	7,95	11,13	50,80	CR 99081
19,81	19,91	19,84	23,75	7,95	11,13	50,80	CR 99080
19,94	20,04	19,99	23,62	8,00	11,00	50,80	CR 99078
20,62	20,70	20,65	30,18	9,53	14,30	76,20	CR 99083
21,77	21,87	21,82	29,34	6,35	9,53	50,80	CR 99086
21,87	22,00	22,00 22,00	30,18 30,18	6,58 8,00	9,12 11,99	47,14 46,02	CR 99084 CR 99085
22,17	22,28	22,23 22,23	27,79 27,79	7,95 7,95	11,13 11,13	50,80 50,80	CR 99812 ²⁾ CR 99087

¹⁾ Possible max. distance of the rear groove from the shaft end when the installation tool supplied with the sleeve is used

²⁾ SKF SPEEDI-SLEEVE Gold

Shaft diameter range		Nominal dimensions					Designation
d ₁ min	max	d ₁	D ±1,6	b ₁ ±0,8	b ±0,8	B ¹⁾	
mm		mm					–
23,06	23,16	23,11	30,94	7,95	11,13	46,91	CR 99860 ²⁾
		23,11	30,94	7,95	11,13	46,91	CR 99091
23,88	24,00	24,00	28,70	7,95	11,13	50,80	CR 99092
24,54	24,64	24,61	28,70	7,95	11,13	50,80	CR 99094
		24,61	28,70	15,88	18,26	50,80	CR 99096
24,94	25,04	24,99	33,02	7,95	11,00	50,80	CR 99813 ²⁾
		24,99	33,02	7,95	11,00	50,80	CR 99098
25,35	25,45	25,40	30,96	7,95	11,13	50,80	CR 99814 ²⁾
		25,40	30,96	7,95	11,13	50,80	CR 99100
25,88	26,01	26,01	33,35	8,00	11,99	46,05	CR 99103
26,92	27,03	27,00	33,53	7,95	11,13	46,81	CR 99815 ²⁾
		27,00	33,53	7,95	11,13	46,81	CR 99106
27,61	27,71	27,66	35,71	7,95	11,13	15,88	CR 99108
27,94	28,04	27,99	34,93	9,53	12,70	46,81	CR 99866 ³⁾
		27,99	34,93	9,53	12,70	46,81	CR 99111
28,52	28,63	28,58	38,10	7,95	11,13	17,48	CR 99816 ²⁾
		28,58	38,10	7,95	11,13	17,48	CR 99112
		28,58	38,10	9,53	12,70	17,48	CR 99116
29,31	29,41	29,36	34,29	9,53	12,70	17,48	CR 99865 ³⁾
		29,36	34,29	9,53	12,70	17,48	CR 99120
29,79	29,92	29,85	35,56	7,95	11,13	17,48	CR 99122
29,95	30,07	30,00	35,56	8,00	11,00	17,48	CR 99114
30,10	30,23	30,18	35,56	7,95	11,13	17,48	CR 99118
30,89	31,04	30,96	39,70	7,95	11,00	15,88	CR 99123
31,42	31,57	31,50	39,12	8,00	11,13	17,48	CR 99141
31,67	31,83	31,75	38,10	7,95	11,13	17,48	CR 99817 ²⁾
		31,75	38,10	7,95	11,13	17,48	CR 99125
31,93	32,08	32,00	38,10	8,00	11,13	17,48	CR 99128
32,94	33,05	32,99	40,49	15,01	18,01	25,40	CR 99121
33,22	33,38	33,35	40,64	6,35	9,53	20,65	CR 99129
33,27	33,43	33,35	40,49	12,70	15,88	20,65	CR 99818 ³⁾
		33,35	40,49	12,70	15,88	20,65	CR 99131
33,86	34,01	34,01	41,28	12,70	15,88	20,65	CR 99134
34,82	34,98	34,93	41,61	7,95	11,13	20,65	CR 99133
		34,93	41,61	12,70	15,88	20,65	CR 99819 ²⁾
		34,93	41,61	12,70	15,88	20,65	CR 99138
34,93	35,08	34,93	41,61	13,00	16,00	20,65	CR 99820 ²⁾
		34,93	41,61	13,00	16,00	20,65	CR 99139
35,84	35,99	35,99	45,24	13,00	16,99	24,99	CR 99146

¹⁾ Possible max. distance of the rear groove from the shaft end when the installation tool supplied with the sleeve is used

²⁾ SKF SPEEDI-SLEEVE Gold

³⁾ SKF SPEEDI-SLEEVE Gold – contact SKF for availability

SKF SPEEDI-SLEEVE – metric (converted from inch dimensions)
d₁ 36,37 – 54,10 mm

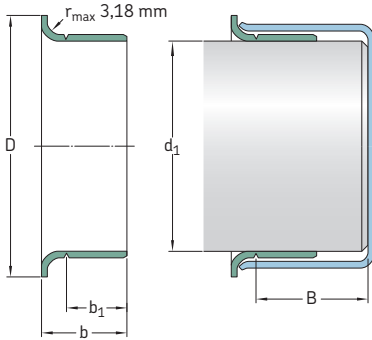

Shaft diameter range		Nominal dimensions					Designation
d ₁ min	max	d ₁	D ±1,6	b ₁ ±0,8	b ±0,8	B ¹⁾	
mm		mm					–
36,37	36,53	36,53 36,53	45,24 45,24	14,30 14,30	17,48 17,48	25,81 25,81	CR 99821²⁾ CR 99143
36,45	36,60	36,53	45,24	9,53	12,70	25,81	CR 99144
37,85	38,00	38,00	45,24	13,00	16,99	24,99	CR 99147
38,02	38,18	38,10 38,10 38,10 38,10	45,24 45,24 45,24 45,24	9,53 9,53 14,30 14,30	12,70 12,70 17,48 17,48	25,81 25,81 25,81 25,81	CR 99823²⁾ CR 99150 CR 99822²⁾ CR 99149
38,61	38,76	38,68	47,22	11,13	14,30	25,81	CR 99152
39,34	39,50	39,42	47,22	11,13	14,30	25,81	CR 99155
39,60	39,75	39,67 39,67	47,22 47,22	14,30 14,30	17,48 17,48	25,81 25,81	CR 99824²⁾ CR 99156
39,78	39,93	39,85	47,22	15,88	19,05	25,81	CR 99159
39,85	40,01	40,01	46,99	9,91	12,93	25,40	CR 99153
39,93	40,08	40,08 40,08	46,99 46,99	13,00 13,00	16,00 16,00	25,98 25,98	CR 99825²⁾ CR 99157
40,69	40,84	40,77	49,23	12,70	16,28	25,40	CR 99160
40,84	41,00	41,00	49,23	12,70	15,88	25,81	CR 99163
41,20	41,35	41,28 41,28 41,28	47,63 47,63 47,63	7,95 14,30 14,30	11,13 17,48 17,48	25,81 20,65 20,65	CR 99161 CR 99826²⁾ CR 99162
41,83	42,01	41,91 41,91 42,01	53,01 53,01 53,01	11,30 14,30 14,30	14,50 17,50 17,50	21,49 21,01 21,01	CR 99166 CR 99169 CR 99873³⁾

¹⁾ Possible max. distance of the rear groove from the shaft end when the installation tool supplied with the sleeve is used

²⁾ SKF SPEEDI-SLEEVE Gold

³⁾ SKF SPEEDI-SLEEVE Gold – contact SKF for availability

Shaft diameter range		Nominal dimensions					Designation
d ₁ min	max	d ₁	D ±1,6	b ₁ ±0,8	b ±0,8	B ¹⁾	
mm	mm	mm					–
41,99	42,14	42,06	53,01	13,97	17,50	21,01	CR 99165
42,77	42,93	42,88	48,41	14,30	17,48	22,23	CR 99168
42,80	42,95	42,88	48,41	7,95	11,13	22,23	CR 99167
42,85	43,00	43,00	48,41	12,70	15,88	21,44	CR 99182
43,56	43,71	43,66	51,59	14,30	17,48	20,65	CR 99171
44,09	44,25	44,17	52,40	9,53	12,70	20,65	CR 99170
44,37	44,53	44,45	52,20	9,53	12,70	20,65	CR 99172
		44,45	52,40	13,49	15,88	22,30	CR 99180
		44,45	52,40	14,30	17,48	20,65	CR 99827 ²⁾
		44,45	52,40	14,30	17,48	20,65	CR 99174
		44,45	52,40	19,05	22,23	20,65	CR 99828 ²⁾
		44,45	52,40	19,05	22,23	20,65	CR 99175
44,73	44,88	44,86	52,40	14,30	17,48	20,65	CR 99829 ²⁾
		44,86	52,40	14,30	17,48	20,65	CR 99176
44,93	45,09	45,01	53,01	14,00	16,99	20,62	CR 99830 ²⁾
		45,01	53,01	14,00	16,99	20,62	CR 99177
45,16	45,31	45,24	53,98	16,94	20,32	26,97	CR 99179
45,95	46,10	46,05	53,09	14,30	17,48	25,40	CR 99831 ³⁾
		46,05	53,09	14,30	17,48	25,40	CR 99181
47,17	47,32	47,22	54,76	14,30	17,48	25,40	CR 99185
47,40	47,55	47,45	55,58	22,58	26,04	25,40	CR 99186
47,55	47,70	47,63	55,96	4,45	7,49	18,90	CR 99190
		47,63	55,96	7,49	10,54	18,90	CR 99188
		47,63	55,96	9,53	13,11	26,67	CR 99184
		47,63	55,96	14,30	17,48	25,40	CR 99832 ²⁾
		47,63	55,96	14,30	17,48	25,40	CR 99187
47,93	48,08	48,03	56,01	14,00	16,97	24,99	CR 99189
48,49	48,64	48,56	56,36	9,53	12,70	25,40	CR 99192
49,12	49,28	49,23	56,36	14,30	17,48	25,40	CR 99833 ²⁾
		49,23	56,36	14,30	17,48	25,40	CR 99193
49,91	50,06	50,01	57,00	14,00	16,97	24,99	CR 99196
50,22	50,37	50,29	58,75	14,30	17,88	26,67	CR 99198
50,72	50,88	50,80	61,11	14,30	17,48	25,55	CR 99834 ²⁾
		50,80	61,11	14,30	17,48	25,40	CR 99199
		50,80	61,11	22,23	25,40	25,40	CR 99835 ²⁾
		50,80	61,11	22,23	25,40	25,40	CR 99200
51,82	51,99	51,99	62,71	12,70	15,88	34,52	CR 99204
52,25	52,40	52,40	62,71	19,84	23,83	34,93	CR 99205
53,92	54,05	53,98	61,52	12,70	19,05	32,54	CR 99210
53,95	54,10	53,98	61,52	19,84	23,83	34,93	CR 99836 ²⁾
		53,98	61,52	19,84	23,83	34,93	CR 99212

¹⁾ Possible max. distance of the rear groove from the shaft end when the installation tool supplied with the sleeve is used

²⁾ SKF SPEEDI-SLEEVE Gold

³⁾ SKF SPEEDI-SLEEVE Gold – contact SKF for availability

SKF SPEEDI-SLEEVE – metric (converted from inch dimensions)

d_1 54,91 – 74,75 mm

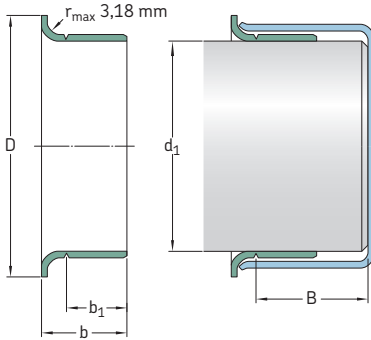

Shaft diameter range		Nominal dimensions					Designation
d_1 min	max	d_1	D $\pm 1,6$	b_1 $\pm 0,8$	b $\pm 0,8$	B^1	
mm		mm					–
54,91	55,07	54,99	62,00	19,99	22,99	31,75	CR 99863 ²⁾
		54,99	62,00	19,99	22,99	31,75	CR 99215
55,52	55,68	55,58	63,50	19,84	23,83	33,35	CR 99218
55,83	56,01	56,01	64,29	12,70	15,88	33,35	CR 99220
		56,01	64,29	19,79	23,77	80,01	CR 99224
56,57	56,72	56,64	64,29	12,70	15,88	33,35	CR 99861 ³⁾
		56,64	64,29	12,70	15,88	33,35	CR 99229
		56,64	64,29	19,84	23,01	31,75	CR 99230
56,82	56,97	56,90	65,10	19,41	22,86	31,75	CR 99226
57,12	57,28	57,15	64,29	7,95	11,13	33,35	CR 99838 ³⁾
		57,15	64,29	7,95	11,13	33,35	CR 99227
		57,15	64,29	19,84	23,83	33,35	CR 99837 ²⁾
		57,15	64,29	19,84	23,83	33,35	CR 99225
57,91	58,06	57,99	65,99	19,99	23,83	34,93	CR 99219
58,65	58,80	58,75	68,28	19,84	23,83	34,93	CR 99231
59,11	59,26	59,13	69,85	19,05	22,23	38,10	CR 99233
59,92	60,07	59,99	70,74	9,40	11,43	37,36	CR 99241
		59,99	70,74	19,99	22,99	34,93	CR 99869 ³⁾
		59,99	70,74	19,99	22,99	34,93	CR 99235
60,25	60,40	60,33	69,85	15,09	19,05	34,93	CR 99238
60,30	60,45	60,33	69,85	13,36	17,35	34,93	CR 99240
		60,33	69,85	19,84	23,83	34,93	CR 99839 ²⁾
		60,33	69,85	19,84	23,83	34,93	CR 99237
61,82	62,00	61,93	71,83	19,84	23,83	35,38	CR 99243
		62,00	71,83	12,70	15,88	36,20	CR 99244

¹⁾ Possible max. distance of the rear groove from the shaft end when the installation tool supplied with the sleeve is used

²⁾ SKF SPEEDI-SLEEVE Gold

³⁾ SKF SPEEDI-SLEEVE Gold – contact SKF for availability

Shaft diameter range		Nominal dimensions					Designation
d ₁ min	max	d ₁	D ±1,6	b ₁ ±0,8	b ±0,8	B ¹⁾	
mm		mm					–
61,85	62,00	61,93	71,83	12,70	15,88	36,20	CR 99242
63,22	63,37	63,30	73,03	19,84	23,83	35,38	CR 99249
63,42	63,58	63,50	71,63	14,10	16,51	22,61	CR 99253
63,50	63,65	63,50 63,50 63,50	71,83 71,63 71,63	12,70 19,84 19,84	16,66 23,83 23,83	35,38 34,93 34,93	CR 99248 CR 99840²⁾ CR 99250
63,75	63,91	63,91	71,83	19,84	23,01	36,53	CR 99251
64,92	65,07	65,00 65,00	72,39 72,39	19,99 19,99	22,99 22,99	34,93 34,93	CR 99841²⁾ CR 99254
65,02	65,18	65,10	73,43	19,84	23,83	34,93	CR 99256
65,91	66,07	65,99	75,95	19,84	23,83	31,75	CR 99259
66,50	66,65	66,57	77,39	19,84	23,83	34,93	CR 99261
66,57	66,73	66,68	77,39	19,84	23,01	34,93	CR 99264
66,60	66,75	66,68	77,39	12,70	15,88	34,93	CR 99260
66,68	66,83	66,68 66,68	77,39 77,39	19,84 19,84	23,83 23,83	34,93 34,93	CR 99842²⁾ CR 99262
67,82	68,00	68,00	79,38	19,05	22,23	42,88	CR 99266
69,27	69,42	69,34	79,38	19,84	23,01	33,35	CR 99268
69,60	69,75	69,67	77,85	19,84	23,83	31,75	CR 99273
69,72	69,88	69,85 69,85	79,38 79,38	19,84 19,84	23,83 23,83	31,75 31,75	CR 99843²⁾ CR 99274
69,77	69,93	69,85	78,11	36,53	41,28	41,28	CR 99267
69,85	70,00	69,85 69,85 69,85 69,85	79,38 79,38 79,38 79,38	10,31 19,84 19,84 28,58	14,30 23,83 23,83 31,75	31,75 31,75 31,75 33,32	CR 99272 CR 99844²⁾ CR 99275 CR 99269
69,93	70,08	70,00	79,38	19,99	24,00	31,75	CR 99276
71,35	71,50	71,45	80,98	15,09	17,48	31,75	CR 99281
71,83	72,01	72,01 72,01	81,92 81,92	19,05 19,05	22,23 22,23	34,11 34,11	CR 99870³⁾ CR 99284
72,09	72,24	72,09 72,09	81,92 81,92	12,70 12,70	16,66 16,66	31,75 31,75	CR 99845²⁾ CR 99282
72,80	72,95	72,87	80,98	19,84	23,83	31,75	CR 99286
72,97	73,13	73,03 73,03	81,76 81,76	19,84 19,84	23,83 23,83	31,75 31,75	CR 99846²⁾ CR 99287
74,60	74,75	74,63 74,63 74,68	84,94 84,94 84,94	12,70 19,84 19,84	16,28 23,83 23,83	33,81 33,35 33,35	CR 99290 CR 99847²⁾ CR 99293

¹⁾ Possible max. distance of the rear groove from the shaft end when the installation tool supplied with the sleeve is used

²⁾ SKF SPEEDI-SLEEVE Gold

³⁾ SKF SPEEDI-SLEEVE Gold – contact SKF for availability

SKF SPEEDI-SLEEVE – metric (converted from inch dimensions)

d_1 **74,93 – 98,53 mm**

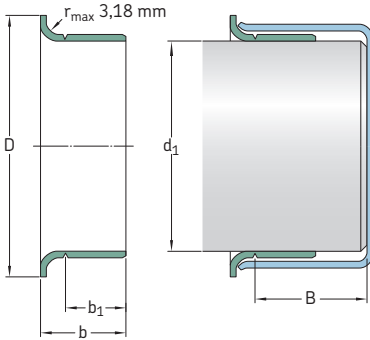

Shaft diameter range		Nominal dimensions					Designation
d_1 min	max	d_1	D $\pm 1,6$	b_1 $\pm 0,8$	b $\pm 0,8$	B ¹⁾	
mm		mm					–
74,93	75,08	75,01	83,13	15,09	17,53	27,51	CR 99289
		75,01	83,95	22,00	26,01	33,35	CR 99875³⁾
		75,01	83,95	22,00	26,01	33,35	CR 99294
75,49	75,59	75,54	82,17	20,65	25,40	31,75	CR 99292
75,95	76,10	76,02	85,32	12,29	15,88	33,81	CR 99291
		76,02	85,32	14,30	17,48	34,93	CR 99298
		76,02	85,09	20,65	25,40	32,54	CR 99299
76,12	76,28	76,20	82,30	20,65	23,83	34,93	CR 99296
76,20	76,35	76,20	84,96	15,88	20,65	32,51	CR 99303
		76,20	82,17	20,65	25,40	32,54	CR 99848²⁾
		76,20	82,17	20,65	25,40	32,54	CR 99300
76,40	76,56	76,48	85,22	12,70	15,88	50,80	CR 99301
77,83	78,00	78,00	88,09	19,05	22,23	52,22	CR 99306
79,25	79,40	79,38	89,69	17,48	20,65	50,80	CR 99311
		79,38	89,69	20,65	25,40	50,80	CR 99849²⁾
		79,38	89,69	20,65	25,40	50,80	CR 99312
79,35	79,55	79,38	89,54	14,00	18,01	51,59	CR 99307
79,81	80,01	80,01	89,92	19,05	22,50	34,93	CR 99313
79,91	80,09	80,01	89,99	11,00	15,01	34,93	CR 99317
		80,01	89,99	21,01	24,00	34,93	CR 99315
81,92	82,07	81,99	91,06	16,76	21,54	44,45	CR 99328
82,47	82,63	82,55	91,29	20,65	25,40	34,93	CR 99322

¹⁾ Possible max. distance of the rear groove from the shaft end when the installation tool supplied with the sleeve is used

²⁾ SKF SPEEDI-SLEEVE Gold

³⁾ SKF SPEEDI-SLEEVE Gold – contact SKF for availability

Shaft diameter range		Nominal dimensions					Designation
d ₁ min	max	d ₁	D ±1,6	b ₁ ±0,8	b ±0,8	B ¹⁾	
mm		mm					–
82,55	82,70	82,55	90,81	15,11	18,26	34,93	CR 99850²⁾
		82,55	90,81	15,11	18,26	34,93	CR 99324
		82,55	91,06	17,48	22,23	31,75	CR 99326
		82,55	91,06	20,65	25,40	34,93	CR 99851²⁾
		82,55	91,06	20,65	25,40	34,93	CR 99325
84,00	84,15	84,07	93,68	20,65	25,40	34,93	CR 99331
84,76	85,01	84,89	93,98	16,99	21,01	35,00	CR 99332
		84,89	93,98	21,01	24,99	35,00	CR 99872²⁾
		84,89	93,98	21,01	24,99	35,00	CR 99333
84,79	85,01	85,01	90,93	10,13	12,67	36,35	CR 99334
85,67	85,83	85,73	93,68	9,53	12,70	35,81	CR 99338
		85,73	93,85	20,65	25,40	34,93	CR 99337
87,25	87,40	87,33	97,64	19,84	23,01	35,71	CR 99339
87,80	88,00	88,00	95,28	29,21	34,27	42,50	CR 99481
88,32	88,47	88,39	97,41	19,84	23,01	35,71	CR 99340
88,82	88,98	88,90	97,64	15,88	20,65	34,21	CR 99346
88,90	89,05	88,90	97,16	7,95	12,70	34,21	CR 99347
		88,90	97,64	20,65	25,40	34,21	CR 99852²⁾
		88,90	97,64	20,65	25,40	34,21	CR 99350
88,93	89,08	89,00	97,64	15,88	20,65	34,24	CR 99349
89,92	90,07	89,99	101,60	11,13	13,67	46,05	CR 99352
		89,99	101,60	13,36	16,94	44,45	CR 99353
		89,99	101,60	18,03	23,01	46,05	CR 99351
		89,99	101,60	23,01	27,99	44,45	CR 99354
90,42	90,58	90,50	99,06	20,65	25,40	44,45	CR 99356
91,90	92,05	91,97	102,39	20,65	25,40	44,45	CR 99360
92,02	92,18	92,08	102,24	12,70	15,88	44,45	CR 99363
		92,08	102,39	20,65	25,40	44,45	CR 99362
93,57	93,73	93,68	102,39	7,95	11,13	22,23	CR 99368
93,60	93,75	93,68	102,24	20,65	23,83	45,72	CR 99365
94,67	94,82	94,74	102,01	11,91	15,09	45,72	CR 99359
		94,74	102,24	19,84	23,01	45,72	CR 99366
94,92	95,07	95,00	102,24	21,01	24,00	45,72	CR 99369
95,00	95,15	95,07	102,39	8,74	12,70	45,72	CR 99374
		95,07	102,49	11,91	15,09	45,72	CR 99364
95,15	95,30	95,22	102,24	14,30	17,48	45,72	CR 99376
95,25	95,40	95,25	102,11	17,48	22,23	45,72	CR 99853²⁾³⁾
		95,33	102,24	8,74	12,70	45,72	CR 99367
		95,33	102,11	17,48	22,23	45,72	CR 99372²⁾
98,25	98,40	98,32	106,30	20,65	25,40	47,63	CR 99386
98,37	98,53	98,43	107,16	20,65	25,40	47,63	CR 99387

¹⁾ Possible max. distance of the rear groove from the shaft end when the installation tool supplied with the sleeve is used

²⁾ SKF SPEEDI-SLEEVE Gold

³⁾ Renamed CR 99372

SKF SPEEDI-SLEEVE – metric (converted from inch dimensions)

d₁ 99,95 – 152,48 mm

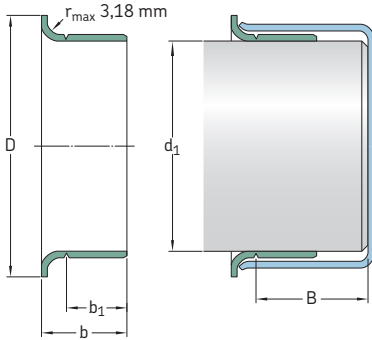

Shaft diameter range		Nominal dimensions					Designation	
d ₁ min	max	d ₁	D ±1,6	b ₁ ±0,8	b ±0,8	B ¹⁾		
mm		mm						–
99,95	100,10	100,03 100,03	109,55 109,55	20,65 20,65	25,40 25,40	52,07 52,07	CR 99854²⁾ CR 99393	
101,55	101,75	101,60 101,60 101,60 101,60 101,60	111,13 111,13 111,13 111,13 111,13	12,70 15,24 16,51 20,65 20,65	15,88 18,42 19,69 25,40 25,40	52,48 52,07 34,93 52,07 52,07	CR 99401 CR 99395 CR 99400 CR 99855²⁾ CR 99399	
103,89	104,09	103,99	112,73	19,99	24,00	35,99	CR 99409	
104,70	104,90	104,78	113,54	20,65	25,40	34,93	CR 99412	
104,90	105,11	105,00	113,54	19,99	23,19	35,00	CR 99413	
106,25	106,45	106,38	114,30	20,65	25,40	34,93	CR 99418	
107,34	107,54	107,54	117,09	19,84	23,01	36,53	CR 99423	
107,90	108,10	107,95	117,09	20,65	25,40	36,53	CR 99424	
109,78	110,01	110,01	124,99	11,38	14,96	32,94	CR 99434	
109,91	110,11	109,93	124,99	12,93	16,51	31,75	CR 99435	
111,00	111,20	111,13	120,65	20,65	25,40	41,91	CR 99437	
111,79	111,99	111,99	120,65	19,05	22,50	33,02	CR 99438	
112,62	112,83	112,73	122,25	25,40	29,01	33,35	CR 99439	
114,20	114,40	114,30 114,30	123,19 124,46	20,65 20,65	25,40 25,40	31,75 31,75	CR 99856²⁾ CR 99450	
114,88	115,09	115,01	127,00	20,65	23,83	31,75	CR 99452	
117,37	117,58	117,48 117,48	127,00 128,60	11,13 25,40	15,88 31,75	34,93 34,93	CR 99465 CR 99463	

¹⁾ Possible max. distance of the rear groove from the shaft end when the installation tool supplied with the sleeve is used

²⁾ SKF SPEEDI-SLEEVE Gold

Shaft diameter range		Nominal dimensions					Designation
d ₁ min	max	d ₁	D ±1,6	b ₁ ±0,8	b ±0,8	B ¹⁾	
mm		mm					–
119,00	119,20	119,08	128,60	20,65	25,40	34,93	CR 99468
119,89	120,09	119,99 119,99	129,79 129,79	8,00 19,99	11,00 24,99	33,60 32,00	CR 99471 CR 99473
120,55	120,75	120,65	127,00	12,70	19,05	38,10	CR 99475
121,89	122,10	122,00	131,50	19,99	24,00	32,00	CR 99472
122,91	123,11	123,01	132,82	19,99	24,99	31,60	CR 99484
123,72	123,93	123,83	133,35	15,88	19,05	36,53	CR 99487
124,89	125,10	124,99 124,99	137,16 137,16	10,01 26,01	14,00 32,00	36,53 36,53	CR 99490 CR 99492
126,95	127,15	127,00 127,00 127,00 127,00 127,00	137,16 137,16 137,16 136,91 136,91	13,72 17,48 17,48 20,65 20,65	17,30 22,23 22,23 25,40 25,40	36,53 36,53 36,53 36,53 36,53	CR 99501 CR 99857²⁾ CR 99498 CR 99858²⁾ CR 99499
127,80	128,00	128,00	135,26	29,21	34,27	40,30	CR 99482
129,79	130,00	129,90	139,52	19,05	23,83	30,00	CR 99494
129,97	130,18	130,00 130,18	139,52 139,52	22,00 22,00	25,30 25,30	32,51 32,51	CR 99874³⁾ CR 99491
130,05	130,25	130,18	139,70	20,65	25,40	31,75	CR 99513
133,25	133,45	133,35	141,22	20,65	25,40	31,75	CR 99525
134,80	135,00	134,90	145,67	20,50	25,40	31,75	CR 99533
136,42	136,63	136,53	149,23	20,65	25,40	31,75	CR 99537
138,02	138,23	138,13	146,05	38,10	42,88	47,63	CR 99548
138,99	139,19	139,09	149,86	14,30	19,05	31,34	CR 99547
139,65	139,85	139,70 139,70 139,70	150,83 150,83 150,83	13,16 20,65 20,65	17,91 25,40 25,40	31,75 31,75 31,75	CR 99550 CR 99859³⁾ CR 99549
139,90	140,11	140,00	151,00	20,50	25,40	31,75	CR 99552
142,77	142,98	142,88	157,18	22,23	25,40	46,02	CR 99560
144,75	145,01	145,01	154,94	19,05	22,23	46,02	CR 99571
145,44	145,64	145,64	154,94	14,30	19,05	49,23	CR 99562
145,95	146,15	146,05	156,97	20,65	25,40	44,45	CR 99575
149,12	149,33	149,23 149,23	157,18 157,18	25,40 25,40	31,75 31,75	33,35 33,35	CR 99862²⁾ CR 99587
149,76	150,01	149,99	159,00	26,01	30,00	32,51	CR 99595
150,72	150,93	150,83	161,93	25,40	28,58	47,63	CR 99596
152,27	152,48	152,40 152,40	161,54 161,93	12,70 25,40	19,05 31,75	44,45 44,45	CR 99601 CR 99599

¹⁾ Possible max. distance of the rear groove from the shaft end when the installation tool supplied with the sleeve is used

²⁾ SKF SPEEDI-SLEEVE Gold

³⁾ SKF SPEEDI-SLEEVE Gold – contact SKF for availability

SKF SPEEDI-SLEEVE – metric (converted from inch dimensions)

d_1 153,87 – 203,33 mm

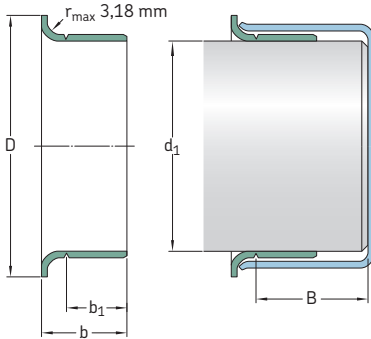

Shaft diameter range		Nominal dimensions					Designation
d_1 min	max	d_1	D $\pm 1,6$	b_1 $\pm 0,8$	b $\pm 0,8$	$B^1)$	
mm		mm					–
153,87	154,13	154,00	161,93	26,01	30,00	32,99	CR 99605
154,74	154,99	154,86	167,01	26,01	30,00	32,99	CR 99606
157,43	157,68	157,56	168,28	20,65	27,00	44,45	CR 99620
158,62	158,88	158,75	168,28	26,19	31,75	44,45	CR 99625
159,74	159,99	159,99	171,45	25,40	31,75	34,93	CR 99630
164,97	165,23	165,10	177,80	25,40	31,75	34,93	CR 99650
169,75	170,00	169,88	182,58	31,75	38,00	44,45	CR 99640
171,32	171,58	171,45	180,98	20,65	27,00	44,45	CR 99675
174,75	175,01	175,01	186,99	27,99	32,00	35,00	CR 99687
177,67	177,93	177,80 177,80	189,87 189,87	25,40 25,40	31,75 31,75	42,88 42,88	CR 99864 ²⁾ CR 99700
179,76	180,01	180,01	190,50	32,99	38,00	44,50	CR 99721
184,00	184,25	184,15	197,10	31,75	38,10	55,25	CR 99725
184,73	184,99	184,86	197,10	32,00	38,00	54,99	CR 99726
189,08	189,33	189,31	199,64	20,65	25,40	31,75	CR 99745
190,37	190,63	190,50	200,03	20,65	25,40	31,75	CR 99750
196,72	196,98	196,85	210,06	25,40	33,35	47,63	CR 99775
199,87	200,13	200,03	212,73	34,52	38,10	44,45	CR 99787
201,50	201,75	201,63	212,73	25,40	31,75	44,45	CR 99799
203,07	203,33	203,20	212,73	25,40	31,75	44,45	CR 99800

¹⁾ Possible max. distance of the rear groove from the shaft end when the installation tool supplied with the sleeve is used

²⁾ SKF SPEEDI-SLEEVE Gold – contact SKF for availability

SKF SPEEDI-SLEEVE – inch dimensions

d_1 0.472 – 0.877 in.

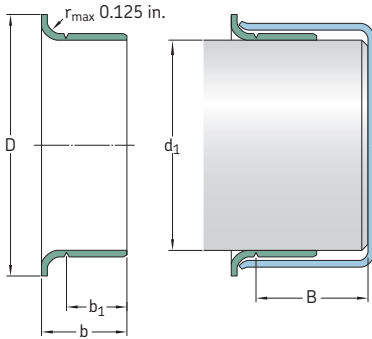

Shaft diameter range		Nominal dimensions					Designation	
d_1 min	max	d_1	D ± 0.063	b_1 ± 0.031	b ± 0.031	$B^1)$		
in.		in.						–
0.472	0.475	0.472	0.610	0.236	0.331	1.875	CR 99049	
0.498	0.502	0.500	0.610	0.250	0.344	2.000	CR 99050	
0.547	0.551	0.551	0.750	0.250	0.391	1.831	CR 99055	
0.560	0.566	0.563	0.750	0.250	0.391	1.831	CR 99056	
0.589	0.593	0.591	0.750	0.197	0.354	1.862	CR 99059	
0.623	0.627	0.625	0.750	0.313	0.406	2.000	CR 99810 ²⁾	
		0.625	0.750	0.313	0.406	2.000	CR 99062	
0.626	0.630	0.630	0.718	0.313	0.438	2.000	CR 99058	
0.667	0.671	0.669	0.875	0.315	0.433	2.000	CR 99068	
0.682	0.686	0.684	0.900	0.313	0.438	2.000	CR 99060	
0.704	0.709	0.709	0.962	0.315	0.433	1.811	CR 99082	
0.748	0.752	0.750	0.945	0.313	0.438	2.000	CR 99811 ²⁾	
		0.750	0.945	0.313	0.438	2.000	CR 99076	
0.759	0.761	0.760	0.938	0.313	0.438	2.000	CR 99081	
0.780	0.784	0.781	0.935	0.313	0.438	2.000	CR 99080	
0.785	0.789	0.787	0.930	0.315	0.433	2.000	CR 99078	
0.812	0.815	0.813	1.188	0.375	0.563	3.000	CR 99083	
0.857	0.861	0.859	1.155	0.250	0.375	2.000	CR 99086	
0.861	0.866	0.866	1.188	0.259	0.359	1.856	CR 99084	
		0.866	1.188	0.315	0.472	1.812	CR 99085	
0.873	0.877	0.875	1.094	0.313	0.438	2.000	CR 99812 ²⁾	
		0.875	1.094	0.313	0.438	2.000	CR 99087	

¹⁾ Possible max. distance of the rear groove from the shaft end when the installation tool supplied with the sleeve is used

²⁾ SKF SPEEDI-SLEEVE Gold

SKF SPEEDI-SLEEVE – inch dimensions

d_1 0.908 – 1.659 in.

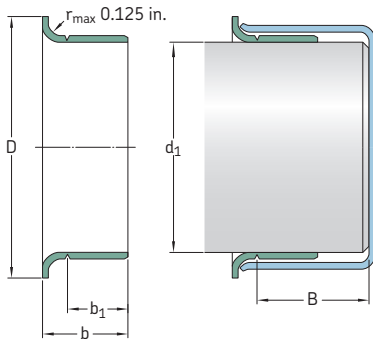

Shaft diameter range		Nominal dimensions					Designation	
d_1 min	max	d_1	D ± 0.063	b_1 ± 0.031	b ± 0.031	$B^1)$		
in.		in.						–
0.908	0.912	0.910 0.910	1.218 1.218	0.313 0.313	0.438 0.438	1.847 1.847	CR 99860 ²⁾ CR 99091	
0.940	0.945	0.945	1.130	0.313	0.438	2.000	CR 99092	
0.966	0.970	0.969 0.969	1.130 1.130	0.313 0.625	0.438 0.719	2.000 2.000	CR 99094 CR 99096	
0.982	0.986	0.984 0.984	1.300 1.300	0.313 0.313	0.433 0.433	2.000 2.000	CR 99813 ²⁾ CR 99098	
0.998	1.002	1.000 1.000	1.219 1.219	0.313 0.313	0.438 0.438	2.000 2.000	CR 99814 ²⁾ CR 99100	
1.019	1.024	1.024	1.313	0.315	0.472	1.813	CR 99103	
1.060	1.064	1.063 1.063	1.320 1.320	0.313 0.313	0.438 0.438	1.843 1.843	CR 99815 ²⁾ CR 99106	
1.087	1.091	1.089	1.406	0.313	0.438	0.625	CR 99108	
1.100	1.104	1.102 1.102	1.375 1.375	0.375 0.375	0.500 0.500	1.843 1.843	CR 99866 ³⁾ CR 99111	
1.123	1.127	1.125 1.125 1.125	1.500 1.500 1.500	0.313 0.313 0.375	0.438 0.438 0.500	0.688 0.688 0.688	CR 99816 ²⁾ CR 99112 CR 99116	
1.154	1.158	1.156 1.156	1.350 1.350	0.375 0.375	0.500 0.500	0.688 0.688	CR 99865 ³⁾ CR 99120	
1.173	1.178	1.175	1.400	0.313	0.438	0.688	CR 99122	
1.179	1.184	1.181	1.400	0.315	0.433	0.688	CR 99114	
1.185	1.190	1.188	1.400	0.313	0.438	0.688	CR 99118	
1.216	1.222	1.219	1.563	0.313	0.433	0.625	CR 99123	

¹⁾ Possible max. distance of the rear groove from the shaft end when the installation tool supplied with the sleeve is used

²⁾ SKF SPEEDI-SLEEVE Gold

³⁾ SKF SPEEDI-SLEEVE Gold – contact SKF for availability

Shaft diameter range		Nominal dimensions					Designation
d ₁ min	max	d ₁	D ±0.063	b ₁ ±0.031	b ±0.031	B ¹⁾	
in.		in.					–
1.237	1.243	1.240	1.540	0.315	0.438	0.688	CR 99141
1.247	1.253	1.250 1.250	1.500 1.500	0.313 0.313	0.438 0.438	0.688 0.688	CR 99817 ²⁾ CR 99125
1.257	1.263	1.260	1.500	0.315	0.438	0.688	CR 99128
1.297	1.301	1.299	1.594	0.591	0.709	1.000	CR 99121
1.308	1.314	1.313	1.600	0.250	0.375	0.813	CR 99129
1.310	1.316	1.313 1.313	1.594 1.594	0.500 0.500	0.625 0.625	0.813 0.813	CR 99818 ³⁾ CR 99131
1.333	1.339	1.339	1.625	0.500	0.625	0.813	CR 99134
1.371	1.377	1.375 1.375 1.375	1.638 1.638 1.638	0.313 0.500 0.500	0.438 0.625 0.625	0.813 0.813 0.813	CR 99133 CR 99819 ²⁾ CR 99138
1.375	1.381	1.375 1.375	1.638 1.638	0.512 0.512	0.630 0.630	0.813 0.813	CR 99820 ²⁾ CR 99139
1.411	1.417	1.417	1.781	0.512	0.669	0.984	CR 99146
1.432	1.438	1.438 1.438	1.781 1.781	0.563 0.563	0.688 0.688	1.016 1.016	CR 99821 ²⁾ CR 99143
1.435	1.441	1.438	1.781	0.375	0.500	1.016	CR 99144
1.490	1.496	1.496	1.781	0.512	0.669	0.984	CR 99147
1.497	1.503	1.500 1.500 1.500 1.500	1.781 1.781 1.781 1.781	0.375 0.375 0.563 0.563	0.500 0.500 0.688 0.688	1.016 1.016 1.016 1.016	CR 99823 ²⁾ CR 99150 CR 99822 ²⁾ CR 99149
1.520	1.526	1.523	1.859	0.438	0.563	1.016	CR 99152
1.549	1.555	1.552	1.859	0.438	0.563	1.016	CR 99155
1.559	1.565	1.562 1.562	1.859 1.859	0.563 0.563	0.688 0.688	1.016 1.016	CR 99824 ²⁾ CR 99156
1.566	1.572	1.569	1.859	0.625	0.750	1.016	CR 99159
1.569	1.575	1.575	1.850	0.390	0.509	1.000	CR 99153
1.572	1.578	1.578 1.578	1.850 1.850	0.512 0.512	0.630 0.630	1.023 1.023	CR 99825 ²⁾ CR 99157
1.602	1.608	1.605	1.938	0.500	0.641	1.000	CR 99160
1.608	1.614	1.614	1.938	0.500	0.625	1.016	CR 99163
1.622	1.628	1.625 1.625 1.625	1.875 1.875 1.875	0.313 0.563 0.563	0.438 0.688 0.688	1.016 0.813 0.813	CR 99161 CR 99826 ²⁾ CR 99162
1.647	1.654	1.650 1.650 1.654	2.087 2.087 2.087	0.445 0.563 0.563	0.571 0.689 0.689	0.846 0.827 0.827	CR 99166 CR 99169 CR 99873 ³⁾
1.653	1.659	1.656	2.087	0.550	0.689	0.827	CR 99165

¹⁾ Possible max. distance of the rear groove from the shaft end when the installation tool supplied with the sleeve is used

²⁾ SKF SPEEDI-SLEEVE Gold

³⁾ SKF SPEEDI-SLEEVE Gold – contact SKF for availability

SKF SPEEDI-SLEEVE – inch dimensions

d_1 1.684 – 2.441 in.

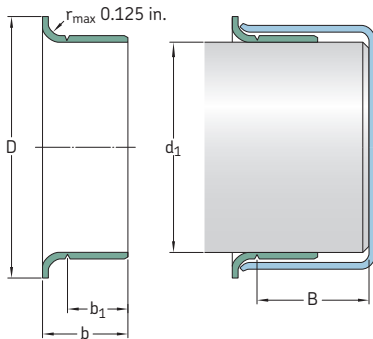

Shaft diameter range		Nominal dimensions					Designation
d_1 min	max	d_1	D ± 0.063	b_1 ± 0.031	b ± 0.031	$B^1)$	
in.		in.					
1.684	1.690	1.688	1.906	0.563	0.688	0.875	CR 99168
1.685	1.691	1.688	1.906	0.313	0.438	0.875	CR 99167
1.687	1.693	1.693	1.906	0.500	0.625	0.844	CR 99182
1.715	1.721	1.719	2.031	0.563	0.688	0.813	CR 99171
1.736	1.742	1.739	2.063	0.375	0.500	0.813	CR 99170
1.747	1.753	1.750	2.055	0.375	0.500	0.813	CR 99172
		1.750	2.063	0.531	0.625	0.878	CR 99180
		1.750	2.063	0.563	0.688	0.813	CR 99827 ²⁾
		1.750	2.063	0.563	0.688	0.813	CR 99174
		1.750	2.063	0.750	0.875	0.813	CR 99828 ²⁾
		1.750	2.063	0.750	0.875	0.813	CR 99175
1.761	1.767	1.766	2.063	0.563	0.688	0.813	CR 99829 ²⁾
		1.766	2.063	0.563	0.688	0.813	CR 99176
1.769	1.775	1.772	2.087	0.551	0.669	0.812	CR 99830 ²⁾
		1.772	2.087	0.551	0.669	0.812	CR 99177
1.778	1.784	1.781	2.125	0.667	0.800	1.062	CR 99179
1.809	1.815	1.813	2.090	0.563	0.688	1.000	CR 99831 ³⁾
		1.813	2.090	0.563	0.688	1.000	CR 99181
1.857	1.863	1.859	2.156	0.563	0.688	1.000	CR 99185
1.866	1.872	1.868	2.188	0.889	1.025	1.000	CR 99186
1.872	1.878	1.875	2.203	0.175	0.295	0.744	CR 99190
		1.875	2.203	0.295	0.415	0.744	CR 99188
		1.875	2.203	0.375	0.516	1.050	CR 99184
		1.875	2.203	0.563	0.688	1.000	CR 99832 ²⁾
		1.875	2.203	0.563	0.688	1.000	CR 99187

¹⁾ Possible max. distance of the rear groove from the shaft end when the installation tool supplied with the sleeve is used

²⁾ SKF SPEEDI-SLEEVE Gold

³⁾ SKF SPEEDI-SLEEVE Gold – contact SKF for availability

Shaft diameter range		Nominal dimensions					Designation
d ₁ min	max	d ₁	D ±0.063	b ₁ ±0.031	b ±0.031	B ¹⁾	
in.		in.					–
1.887	1.893	1.891	2.205	0.551	0.668	0.984	CR 99189
1.909	1.915	1.912	2.219	0.375	0.500	1.000	CR 99192
1.934	1.940	1.938 1.938	2.219 2.219	0.563 0.563	0.688 0.688	1.000 1.000	CR 99833²⁾ CR 99193
1.965	1.971	1.969	2.244	0.551	0.668	0.984	CR 99196
1.977	1.983	1.980	2.313	0.563	0.704	1.050	CR 99198
1.997	2.003	2.000 2.000 2.000 2.000	2.406 2.406 2.406 2.406	0.563 0.563 0.875 0.875	0.688 0.688 1.000 1.000	1.006 1.000 1.000 1.000	CR 99834²⁾ CR 99199 CR 99835²⁾ CR 99200
2.040	2.047	2.047	2.469	0.500	0.625	1.359	CR 99204
2.057	2.063	2.063	2.469	0.781	0.938	1.375	CR 99205
2.123	2.128	2.125	2.422	0.500	0.750	1.281	CR 99210
2.124	2.130	2.125 2.125	2.422 2.422	0.781 0.781	0.938 0.938	1.375 1.375	CR 99836²⁾ CR 99212
2.162	2.168	2.165 2.165	2.441 2.441	0.787 0.787	0.905 0.905	1.250 1.250	CR 99863²⁾ CR 99215
2.186	2.192	2.188	2.500	0.781	0.938	1.313	CR 99218
2.198	2.205	2.205 2.205	2.531 2.531	0.500 0.779	0.625 0.936	1.313 3.150	CR 99220 CR 99224
2.227	2.233	2.230 2.230 2.230	2.531 2.531 2.531	0.500 0.500 0.781	0.625 0.625 0.906	1.313 1.313 1.250	CR 99861³⁾ CR 99229 CR 99230
2.237	2.243	2.240	2.563	0.764	0.900	1.250	CR 99226
2.249	2.255	2.250 2.250 2.250 2.250	2.531 2.531 2.531 2.531	0.313 0.313 0.781 0.781	0.438 0.438 0.938 0.938	1.313 1.313 1.313 1.313	CR 99838³⁾ CR 99227 CR 99837²⁾ CR 99225
2.280	2.286	2.283	2.598	0.787	0.938	1.375	CR 99219
2.309	2.315	2.313	2.688	0.781	0.938	1.375	CR 99231
2.327	2.333	2.328	2.750	0.750	0.875	1.500	CR 99233
2.359	2.365	2.362 2.362 2.362	2.785 2.785 2.785	0.370 0.787 0.787	0.450 0.905 0.905	1.471 1.375 1.375	CR 99241 CR 99869³⁾ CR 99235
2.372	2.378	2.375	2.750	0.594	0.750	1.375	CR 99238
2.374	2.380	2.375 2.375 2.375	2.750 2.750 2.750	0.526 0.781 0.781	0.683 0.938 0.938	1.375 1.375 1.375	CR 99240 CR 99839²⁾ CR 99237
2.434	2.441	2.438 2.441	2.828 2.828	0.781 0.500	0.938 0.625	1.393 1.425	CR 99243 CR 99244
2.435	2.441	2.438	2.828	0.500	0.625	1.425	CR 99242

¹⁾ Possible max. distance of the rear groove from the shaft end when the installation tool supplied with the sleeve is used

²⁾ SKF SPEEDI-SLEEVE Gold

³⁾ SKF SPEEDI-SLEEVE Gold – contact SKF for availability

SKF SPEEDI-SLEEVE – inch dimensions

d_1 2.489 – 3.256 in.

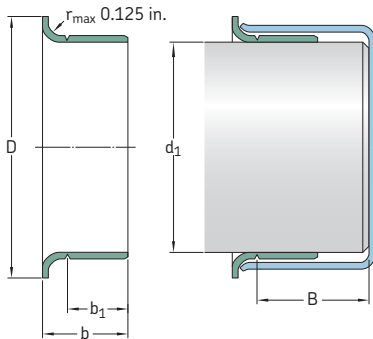

Shaft diameter range		Nominal dimensions					Designation	
d_1 min	max	d_1	D ± 0.063	b_1 ± 0.031	b ± 0.031	$B^1)$		
in.		in.						–
2.489	2.495	2.492	2.875	0.781	0.938	1.393	CR 99249	
2.497	2.503	2.500	2.820	0.555	0.650	0.890	CR 99253	
2.500	2.506	2.500	2.828	0.500	0.656	1.393	CR 99248	
		2.500	2.820	0.781	0.938	1.375	CR 99840 ²⁾	
		2.500	2.820	0.781	0.938	1.375	CR 99250	
2.510	2.516	2.516	2.828	0.781	0.906	1.438	CR 99251	
2.556	2.562	2.559	2.850	0.787	0.905	1.375	CR 99841 ²⁾	
		2.559	2.850	0.787	0.905	1.375	CR 99254	
2.560	2.566	2.563	2.891	0.781	0.938	1.375	CR 99256	
2.595	2.601	2.598	2.990	0.781	0.938	1.250	CR 99259	
2.618	2.624	2.621	3.047	0.781	0.938	1.375	CR 99261	
2.621	2.627	2.625	3.047	0.781	0.906	1.375	CR 99264	
2.622	2.628	2.625	3.047	0.500	0.625	1.375	CR 99260	
2.625	2.631	2.625	3.047	0.781	0.938	1.375	CR 99842 ²⁾	
		2.625	3.047	0.781	0.938	1.375	CR 99262	
2.670	2.677	2.677	3.125	0.750	0.875	1.688	CR 99266	
2.727	2.733	2.730	3.125	0.781	0.906	1.313	CR 99268	
2.740	2.746	2.743	3.065	0.781	0.938	1.250	CR 99273	
2.745	2.751	2.750	3.125	0.781	0.938	1.250	CR 99843 ²⁾	
		2.750	3.125	0.781	0.938	1.250	CR 99274	
2.747	2.753	2.750	3.075	1.438	1.625	1.625	CR 99267	

¹⁾ Possible max. distance of the rear groove from the shaft end when the installation tool supplied with the sleeve is used

²⁾ SKF SPEEDI-SLEEVE Gold

Shaft diameter range		Nominal dimensions					Designation
d ₁ min	max	d ₁	D ±0.063	b ₁ ±0.031	b ±0.031	B ¹⁾	
in.		in.					–
2.750	2.756	2.750	3.125	0.406	0.563	1.250	CR 99272
		2.750	3.125	0.781	0.938	1.250	CR 99844 ²⁾
		2.750	3.125	0.781	0.938	1.250	CR 99275
		2.750	3.125	1.125	1.250	1.312	CR 99269
2.753	2.759	2.756	3.125	0.787	0.945	1.250	CR 99276
2.809	2.815	2.813	3.188	0.594	0.688	1.250	CR 99281
2.828	2.835	2.835	3.225	0.750	0.875	1.343	CR 99870 ³⁾
		2.835	3.225	0.750	0.875	1.343	CR 99284
2.838	2.844	2.838	3.225	0.500	0.656	1.250	CR 99845 ²⁾
		2.838	3.225	0.500	0.656	1.250	CR 99282
2.866	2.872	2.869	3.188	0.781	0.938	1.250	CR 99286
2.873	2.879	2.875	3.219	0.781	0.938	1.250	CR 99846 ²⁾
		2.875	3.219	0.781	0.938	1.250	CR 99287
2.937	2.943	2.938	3.344	0.500	0.641	1.331	CR 99290
		2.938	3.344	0.781	0.938	1.313	CR 99847 ²⁾
		2.940	3.344	0.781	0.938	1.313	CR 99293
2.950	2.956	2.953	3.273	0.594	0.690	1.083	CR 99289
		2.953	3.305	0.866	1.024	1.313	CR 99875 ³⁾
		2.953	3.305	0.866	1.024	1.313	CR 99294
2.972	2.976	2.974	3.235	0.813	1.000	1.250	CR 99292
2.990	2.996	2.993	3.359	0.484	0.625	1.331	CR 99291
		2.993	3.359	0.563	0.688	1.375	CR 99298
		2.993	3.350	0.813	1.000	1.281	CR 99299
2.997	3.003	3.000	3.240	0.813	0.938	1.375	CR 99296
3.000	3.006	3.000	3.345	0.625	0.813	1.280	CR 99303
		3.000	3.235	0.813	1.000	1.281	CR 99848 ²⁾
		3.000	3.235	0.813	1.000	1.281	CR 99300
3.008	3.014	3.011	3.355	0.500	0.625	2.000	CR 99301
3.064	3.071	3.071	3.468	0.750	0.875	2.056	CR 99306
3.120	3.126	3.125	3.531	0.688	0.813	2.000	CR 99311
		3.125	3.531	0.813	1.000	2.000	CR 99849 ²⁾
		3.125	3.531	0.813	1.000	2.000	CR 99312
3.124	3.132	3.125	3.525	0.551	0.709	2.031	CR 99307
3.142	3.150	3.150	3.540	0.750	0.886	1.375	CR 99313
3.146	3.153	3.150	3.543	0.433	0.591	1.375	CR 99317
		3.150	3.543	0.827	0.945	1.375	CR 99315
3.225	3.231	3.228	3.585	0.660	0.848	1.750	CR 99328
3.247	3.253	3.250	3.594	0.813	1.000	1.375	CR 99322
3.250	3.256	3.250	3.575	0.595	0.719	1.375	CR 99850 ²⁾
		3.250	3.575	0.595	0.719	1.375	CR 99324
		3.250	3.585	0.688	0.875	1.250	CR 99326
		3.250	3.585	0.813	1.000	1.375	CR 99851 ²⁾
		3.250	3.585	0.813	1.000	1.375	CR 99325

¹⁾ Possible max. distance of the rear groove from the shaft end when the installation tool supplied with the sleeve is used

²⁾ SKF SPEEDI-SLEEVE Gold

³⁾ SKF SPEEDI-SLEEVE Gold – contact SKF for availability

SKF SPEEDI-SLEEVE – inch dimensions

d_1 3.307 – 4.728 in.

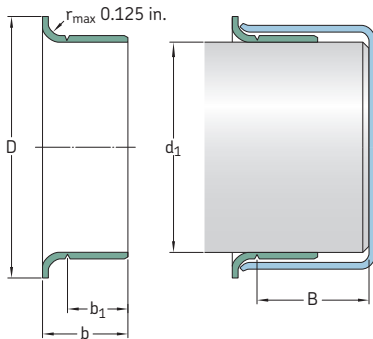

Shaft diameter range		Nominal dimensions					Designation
d_1 min	max	d_1	D ± 0.063	b_1 ± 0.031	b ± 0.031	B^1	
in.		in.					–
3.307	3.313	3.310	3.688	0.813	1.000	1.375	CR 99331
3.337	3.347	3.342	3.700	0.669	0.827	1.378	CR 99332
		3.342	3.700	0.827	0.984	1.378	CR 99872 ²⁾
		3.342	3.700	0.827	0.984	1.378	CR 99333
3.338	3.347	3.347	3.580	0.399	0.499	1.431	CR 99334
3.373	3.379	3.375	3.688	0.375	0.500	1.410	CR 99338
		3.375	3.695	0.813	1.000	1.375	CR 99337
3.435	3.441	3.438	3.844	0.781	0.906	1.406	CR 99339
3.457	3.465	3.465	3.751	1.150	1.349	1.673	CR 99481
3.477	3.483	3.480	3.835	0.781	0.906	1.406	CR 99340
3.497	3.503	3.500	3.844	0.625	0.813	1.347	CR 99346
3.500	3.506	3.500	3.825	0.313	0.500	1.347	CR 99347
		3.500	3.844	0.813	1.000	1.347	CR 99852 ²⁾
		3.500	3.844	0.813	1.000	1.347	CR 99350
3.501	3.507	3.504	3.844	0.625	0.813	1.348	CR 99349
3.540	3.546	3.543	4.000	0.438	0.538	1.813	CR 99352
		3.543	4.000	0.526	0.667	1.750	CR 99353
		3.543	4.000	0.710	0.906	1.813	CR 99351
		3.543	4.000	0.906	1.102	1.750	CR 99354
3.560	3.566	3.563	3.900	0.813	1.000	1.750	CR 99356
3.618	3.624	3.621	4.031	0.813	1.000	1.750	CR 99360
3.623	3.629	3.625	4.025	0.500	0.625	1.750	CR 99363
		3.625	4.031	0.813	1.000	1.750	CR 99362
3.684	3.690	3.688	4.031	0.313	0.438	0.875	CR 99368

¹⁾ Possible max. distance of the rear groove from the shaft end when the installation tool supplied with the sleeve is used

²⁾ SKF SPEEDI-SLEEVE Gold – contact SKF for availability

Shaft diameter range		Nominal dimensions					Designation
d ₁ min	max	d ₁	D ±0.063	b ₁ ±0.031	b ±0.031	B ¹⁾	
in.		in.					–
3.685	3.691	3.688	4.025	0.813	0.938	1.800	CR 99365
3.727	3.733	3.730 3.730	4.016 4.025	0.469 0.781	0.594 0.906	1.800 1.800	CR 99359 CR 99366
3.737	3.743	3.740	4.025	0.827	0.945	1.800	CR 99369
3.740	3.746	3.743 3.743	4.031 4.035	0.344 0.469	0.500 0.594	1.800 1.800	CR 99374 CR 99364
3.746	3.752	3.749	4.025	0.563	0.688	1.800	CR 99376
3.750	3.756	3.750 3.753 3.753	4.020 4.025 4.020	0.688 0.344 0.688	0.875 0.500 0.875	1.800 1.800 1.800	CR 99853²⁾³⁾ CR 99367 CR 99372²⁾
3.868	3.874	3.871	4.185	0.813	1.000	1.875	CR 99386
3.873	3.879	3.875	4.219	0.813	1.000	1.875	CR 99387
3.935	3.941	3.938 3.938	4.313 4.313	0.813 0.813	1.000 1.000	2.050 2.050	CR 99854²⁾ CR 99393
3.998	4.006	4.000 4.000 4.000 4.000 4.000	4.375 4.375 4.375 4.375 4.375	0.500 0.600 0.650 0.813 0.813	0.625 0.725 0.775 1.000 1.000	2.066 2.050 1.375 2.050 2.050	CR 99401 CR 99395 CR 99400 CR 99855²⁾ CR 99399
4.090	4.098	4.094	4.438	0.787	0.945	1.417	CR 99409
4.122	4.130	4.125	4.470	0.813	1.000	1.375	CR 99412
4.130	4.138	4.134	4.470	0.787	0.913	1.378	CR 99413
4.183	4.191	4.188	4.500	0.813	1.000	1.375	CR 99418
4.226	4.234	4.234	4.610	0.781	0.906	1.438	CR 99423
4.248	4.256	4.250	4.610	0.813	1.000	1.438	CR 99424
4.322	4.331	4.331	4.921	0.448	0.589	1.297	CR 99434
4.327	4.335	4.328	4.921	0.509	0.650	1.250	CR 99435
4.370	4.378	4.375	4.750	0.813	1.000	1.650	CR 99437
4.401	4.409	4.409	4.750	0.750	0.886	1.300	CR 99438
4.434	4.442	4.438	4.813	1.000	1.142	1.313	CR 99439
4.496	4.504	4.500 4.500	4.850 4.900	0.813 0.813	1.000 1.000	1.250 1.250	CR 99856²⁾ CR 99450
4.523	4.531	4.528	5.000	0.813	0.938	1.250	CR 99452
4.621	4.629	4.625 4.625	5.000 5.063	0.438 1.000	0.625 1.250	1.375 1.375	CR 99465 CR 99463
4.685	4.693	4.688	5.063	0.813	1.000	1.375	CR 99468
4.720	4.728	4.724 4.724	5.110 5.110	0.315 0.787	0.433 0.984	1.323 1.260	CR 99471 CR 99473

¹⁾ Possible max. distance of the rear groove from the shaft end when the installation tool supplied with the sleeve is used

²⁾ SKF SPEEDI-SLEEVE Gold

³⁾ Renamed CR 99372

SKF SPEEDI-SLEEVE – inch dimensions

d_1 4.746 – 8.005 in.

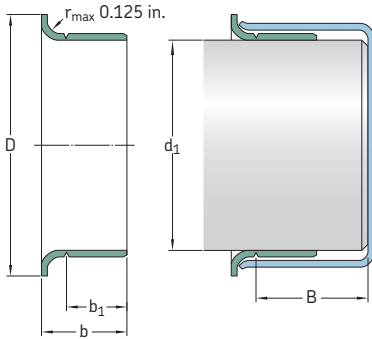

Shaft diameter range		Nominal dimensions					Designation	
d_1 min	max	d_1	D ± 0.063	b_1 ± 0.031	b ± 0.031	B^1		
in.		in.						–
4.746	4.754	4.750	5.000	0.500	0.750	1.500	CR 99475	
4.799	4.807	4.803	5.177	0.787	0.945	1.260	CR 99472	
4.839	4.847	4.843	5.229	0.787	0.984	1.244	CR 99484	
4.871	4.879	4.875	5.250	0.625	0.750	1.438	CR 99487	
4.917	4.925	4.921	5.400	0.394	0.551	1.438	CR 99490	
		4.921	5.400	1.024	1.260	1.438	CR 99492	
4.998	5.006	5.000	5.400	0.540	0.681	1.438	CR 99501	
		5.000	5.400	0.688	0.875	1.438	CR 99857 ²⁾	
		5.000	5.400	0.688	0.875	1.438	CR 99498	
		5.000	5.390	0.813	1.000	1.438	CR 99858 ²⁾	
		5.000	5.390	0.813	1.000	1.438	CR 99499	
5.032	5.039	5.039	5.325	1.150	1.349	1.587	CR 99482	
5.110	5.118	5.114	5.493	0.750	0.938	1.181	CR 99494	
5.117	5.125	5.118	5.493	0.866	0.996	1.280	CR 99874 ³⁾	
		5.125	5.493	0.866	0.996	1.280	CR 99491	
5.120	5.128	5.125	5.500	0.813	1.000	1.250	CR 99513	
5.246	5.254	5.250	5.560	0.813	1.000	1.250	CR 99525	
5.307	5.315	5.311	5.735	0.807	1.000	1.250	CR 99533	
5.371	5.379	5.375	5.875	0.813	1.000	1.250	CR 99537	
5.434	5.442	5.438	5.750	1.500	1.688	1.875	CR 99548	
5.472	5.480	5.476	5.900	0.563	0.750	1.234	CR 99547	

¹⁾ Possible max. distance of the rear groove from the shaft end when the installation tool supplied with the sleeve is used

²⁾ SKF SPEEDI-SLEEVE Gold

³⁾ SKF SPEEDI-SLEEVE Gold – contact SKF for availability

Shaft diameter range		Nominal dimensions					Designation	
d ₁ min	max	d ₁	D ±0.063	b ₁ ±0.031	b ±0.031	B ¹⁾		
in.		in.					-	
5.498	5.506	5.500	5.938	0.518	0.705	1.250	CR 99550	
		5.500	5.938	0.813	1.000	1.250	CR 99859 ³⁾	
		5.500	5.938	0.813	1.000	1.250	CR 99549	
5.508	5.516	5.512	5.945	0.807	1.000	1.250	CR 99552	
5.621	5.629	5.625	6.188	0.875	1.000	1.812	CR 99560	
5.699	5.709	5.709	6.100	0.750	0.875	1.812	CR 99571	
5.726	5.734	5.734	6.100	0.563	0.750	1.938	CR 99562	
5.746	5.754	5.750	6.180	0.813	1.000	1.750	CR 99575	
5.871	5.879	5.875	6.188	1.000	1.250	1.313	CR 99862 ²⁾	
		5.875	6.188	1.000	1.250	1.313	CR 99587	
5.896	5.906	5.905	6.260	1.024	1.181	1.280	CR 99595	
5.934	5.942	5.938	6.375	1.000	1.125	1.875	CR 99596	
5.995	6.003	6.000	6.360	0.500	0.750	1.750	CR 99601	
		6.000	6.375	1.000	1.250	1.750	CR 99599	
6.058	6.068	6.063	6.375	1.024	1.181	1.299	CR 99605	
6.092	6.102	6.097	6.575	1.024	1.181	1.299	CR 99606	
6.198	6.208	6.203	6.625	0.813	1.063	1.750	CR 99620	
6.245	6.255	6.250	6.625	1.031	1.250	1.750	CR 99625	
6.289	6.299	6.299	6.750	1.000	1.250	1.375	CR 99630	
6.495	6.505	6.500	7.000	1.000	1.250	1.375	CR 99650	
6.683	6.693	6.688	7.188	1.250	1.496	1.750	CR 99640	
6.745	6.755	6.750	7.125	0.813	1.063	1.750	CR 99675	
6.880	6.890	6.890	7.362	1.102	1.260	1.378	CR 99687	
6.995	7.005	7.000	7.475	1.000	1.250	1.688	CR 99864 ³⁾	
		7.000	7.475	1.000	1.250	1.688	CR 99700	
7.077	7.087	7.087	7.500	1.299	1.496	1.752	CR 99721	
7.244	7.254	7.250	7.760	1.250	1.500	2.175	CR 99725	
7.273	7.283	7.278	7.760	1.260	1.496	2.165	CR 99726	
7.444	7.454	7.453	7.860	0.813	1.000	1.250	CR 99745	
7.495	7.505	7.500	7.875	0.813	1.000	1.250	CR 99750	
7.745	7.755	7.750	8.270	1.000	1.313	1.875	CR 99775	
7.869	7.879	7.875	8.375	1.359	1.500	1.750	CR 99787	
7.933	7.943	7.938	8.375	1.000	1.250	1.750	CR 99799	
7.995	8.005	8.000	8.375	1.000	1.250	1.750	CR 99800	

¹⁾ Possible max. distance of the rear groove from the shaft end when the installation tool supplied with the sleeve is used

²⁾ SKF SPEEDI-SLEEVE Gold

³⁾ SKF SPEEDI-SLEEVE Gold – contact SKF for availability

Wear sleeves for heavy industrial applications (LDSL3)

General

Outside contamination particles and polishing friction between a rotating shaft and a seal can, over time, result in severe shaft damage. Instead of repairing or replacing the damaged shaft, SKF recommends using wear sleeves for heavy industrial applications (LDSL3) for shaft diameters ranging from 211,15 to 1 143 mm (8.313 to 45 in.). The sleeves are made to order for shaft diameters within the primary ranges listed in **tables 1** and **2**. A selection of sizes is listed in the product tables starting on **page 364**.

LDSL3 and LDSLV4 are recommended for applications where operating conditions for the seals are difficult, particularly where solid contaminants can reach the seals, like in rolling mills, primary metal plants and in chemical and mineral plants.

In applications where seal wear and shaft damage can be expected, SKF recommends installing the sleeves before the machine is operational. By installing them from the outset, it will not be necessary to rework the shaft before installing a replacement sleeve and the original seal size can be used as the replacement.

Table 1

Primary dimension range of LDSLV3

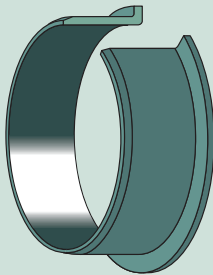

Shaft range		Width ¹⁾	
over	incl.	min	max
mm/in.		mm/in.	
211,15	736,60	17,48	63,50
8.313	29.000	0.688	2.500
736,60	1 143,00	25,40	63,50
29.000	45.000	1.000	2.500

¹⁾ Total width (b), 38,10 to 50,80 mm (1.5 to 2 in.) at 1 143,00 mm (45 in.) shaft diameter

Contact SKF for LDSLV3 designs outside the primary size range.

Table 2

Primary dimension range of LDSLV4

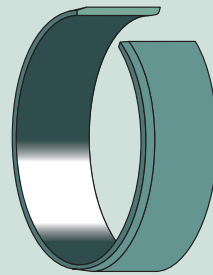

Shaft range		Width ¹⁾	
over	incl.	min	max
mm/in.		mm/in.	
211,15	736,60	12,70	63,50
8.313	29.000	0.500	2.500
736,60	1 143,00	19,05	63,50
29.000	45.000	0.750	2.500

¹⁾ Total width (b), 38,10 to 50,80 mm (1.5 to 2 in.) at 1 143,00 mm (45 in.) shaft diameter

Contact SKF for LDSLV4 designs outside the primary size range.

Designs and features

SKF wear sleeves for heavy industrial applications are available in two designs: the LDSLV3 with a flange (→ **fig. 9**) and the LDSLV4 without a flange (→ **fig. 10**). Both designs are made of SAE 1008 chromium-plated carbon steel to enhance wear and corrosion resistance. Other sleeve materials can be provided to meet the application's specific demands. The sleeve outside diameter is specially ground to provide a precision counterface surface for the seal. The wall thickness of the standard sleeves is 2,39 mm (0.094 in.).

LDSLV3 is designed with a flange to simplify final positioning of the sleeve. The width of the counterface surface for the seal is 6,35 mm (0.25 in.) narrower than the total width of the sleeve. The flange adds a nominal 25,4 mm (1 in.) over the shaft diameter. The flange height is 12,7 mm (0.5 in.) for all sizes. Note that force should never be applied directly to the flange when installing an LDSLV3.

LDSLV4 has the same features as LDSLV3 but has no flange. LDSLV4 is intended for applications where a flange could interfere with other components during installation, or where a wider seal counterface surface is required.

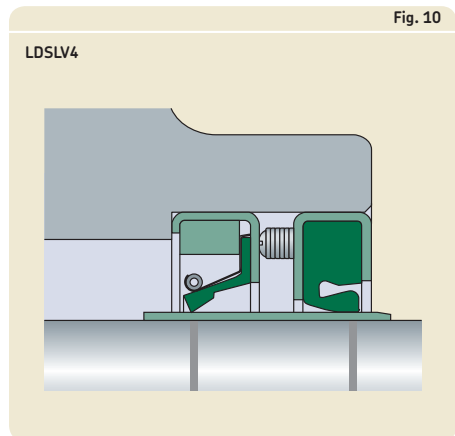
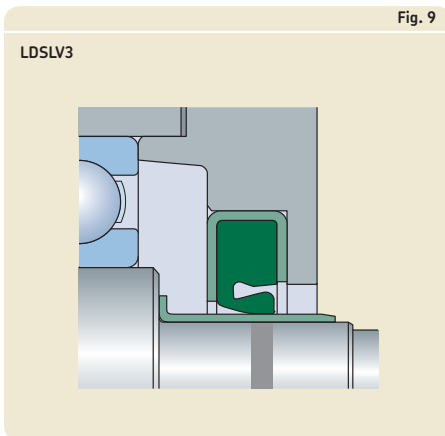

Wear sleeves

Using LDSLV designs

There are two alternative ways of using SKF wear sleeves for heavy industrial applications (→ fig. 11):

- 1 The sleeve is positioned on the shaft until it covers the damaged part and a new seal, designed for a 4,78 mm (0.188 in.) larger shaft diameter, is used.
- 2 The shaft is machined down by 4,78 mm (0.188 in.) in diameter, the sleeve is installed and the original seal size is used.

The reworked shaft surface for the sleeve should have a surface roughness between $R_a 2,5$ and $3,2 \mu\text{m}$ (100 to 125 $\mu\text{in.}$).

NOTE: The shaft tolerances for LDSLV designs, due to their heated slip-fit installation, are different from those for radial shaft seals. Contact SKF for assistance if the sleeves are to be used in systems with sustained temperatures higher than $75 \text{ }^\circ\text{C}$ (165 $^\circ\text{F}$) and surface speeds in excess of 20 m/s (3 900 ft/min).

Installation

SKF wear sleeves for heavy industrial applications are designed for a heated slip-fit installation and must therefore be uniformly heated prior to installation. The sleeve temperature should be approximately $180 \text{ }^\circ\text{C}$ (355 $^\circ\text{F}$). Under no circumstances should the sleeve be heated to above $200 \text{ }^\circ\text{C}$ (390 $^\circ\text{F}$). Any heating techniques normally used for bearings are suitable, such as induction heaters or heating cabinets.

The sleeves should be installed immediately after heating since they cool rapidly and could seize on the shaft before the correct position is achieved. If repositioning is necessary, use a soft faced hammer and a wooden block. After the sleeve is in the desired position, check the lead-in chamfer for any damage during installation.

Removal

The wear sleeves can be removed either by heating them or expanding them by light hammer blows. Prior to removal, the flange of the LDSLV3 should be cut at one point, taking care not to damage the shaft surface.

Fig. 11

Using LDSLV designs

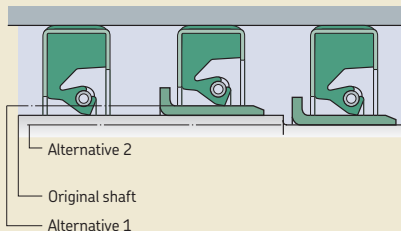

Wear sleeves for heavy industrial applications – LDSLV3 and LDSLV4 – metric dimensions
 d_1 215,00 – 1 100,23 mm

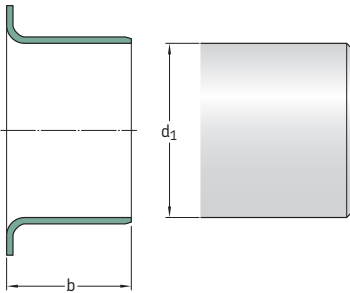

LDSLV3

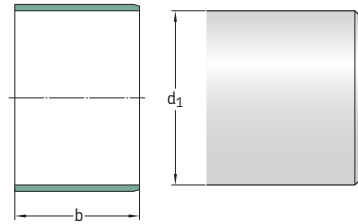

LDSLV4

Shaft diameter	Sleeve width	Reference sleeve installed outside diameter	Design	Designation
d_1	b			
mm	mm	mm	–	–
215,00	25,40	220	LDSLV3	CR 90179
215,20	35	220	LDSLV3	CR 87831
220,00	25 40 50,80	225 225 225	LDSLV3 LDSLV3 LDSLV3	CR 90806 CR 87914 CR 87915
235,23	18	240	LDSLV4	CR 90952
240,00	17,50	250	LDSLV3	CR 90156
240,21	44	245	LDSLV4	CR 87911
245,20	63,50	250	LDSLV3	CR 90766
275,00	22	280	LDSLV4	CR 90546
280,00	45	285	LDSLV4	CR 90437
285,22	63,50	290	LDSLV4	CR 90238
295,20	32	300	LDSLV3	CR 90114
315,19	63,50	320	LDSLV4	CR 90155
320,00	63,50	325	LDSLV4	CR 90198
325,22	63,50	330	LDSLV4	CR 90239
335,22	39 50	340 340	LDSLV4 LDSLV4	CR 90777 CR 90792
340,00	18 50 50	340 340 345	LDSLV4 LDSLV4 LDSLV3	CR 87901 CR 90801 CR 90113
355,20	25,40 50	360 360	LDSLV4 LDSLV4	CR 90778 CR 90785
360,00	44	365	LDSLV4	CR 87500

Shaft diameter d_1	Sleeve width b	Reference sleeve installed outside diameter	Design	Designation
mm	mm	mm	–	–
360,22	45	365	LDSL4	CR 90788
365,20	20	370	LDSL4	CR 87531
395,22	63,50	400	LDSL4	CR 87461
405,23	50	410	LDSL4	CR 90042
419,99	63,50	425	LDSL3	CR 97064
435,20	63,50	440	LDSL4	CR 87916
455,00	30	460	LDSL4	CR 90347
455,20	50	460	LDSL4	CR 87504
475,18	20	480	LDSL4	CR 87921
494,44	24	500	LDSL4	CR 90259
495,20	30	500	LDSL4	CR 87503
503,25	24	508	LDSL4	CR 90149
530,00	20	535	LDSL4	CR 87783
535,23	63	540	LDSL4	CR 90802
555,20	63,50	560	LDSL4	CR 90075
575,23	63,50	580	LDSL4	CR 90951
585,22	55	590	LDSL4	CR 90292
595,20	58,20 63,50	600 600	LDSL3 LDSL4	CR 90120 CR 89997
595,22	50	600	LDSL3	CR 90241
645,20	64	650	LDSL4	CR 90004
645,24	63,50	650	LDSL3	CR 87817
665,20	45	670	LDSL4	CR 90799
685,22	63,50	690	LDSL4	CR 90953
714,81	50	720	LDSL4	CR 87820
735,23	63	740	LDSL4	CR 89949
755,19	63,50	760	LDSL3	CR 87981
865,23	63,50	870	LDSL4	CR 90221
875,18	63,50	880	LDSL4	CR 90103
1 015,20	25	1 020	LDSL4	CR 90786
1 049,33	60	1 054	LDSL4	CR 89947
1 100,23	63	1 105	LDSL4	CR 89946

Wear sleeves for heavy industrial applications – LDSLV3 and LDSLV4 – inch dimensions
 d_1 8.313 – 10.441 in.

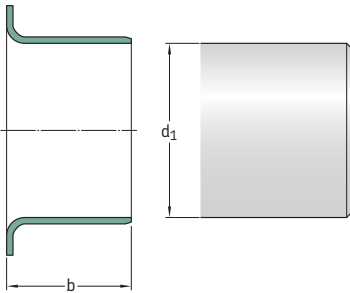

LDSLV3

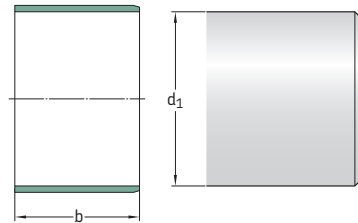

LDSLV4

Shaft diameter	Sleeve width	Reference sleeve installed outside diameter	Design	Designation
d_1	b			
in./mm	in./mm	in./mm	–	–
8.313 211,15	1.250 31,75	8.501 215,93	LDSLV4	CR 85885
8.353 212,17	1.500 38,10	8.541 216,94	LDSLV4	CR 86907
8.500 215,90	1.000 25,40	8.688 220,68	LDSLV3	CR 85158
8.625 219,08	2.750 69,85	8.813 223,85	LDSLV3	CR 85643
8.661 220,00	1.000 25,40	8.849 224,76	LDSLV4	CR 87319
8.687 220,65	2.250 57,15	8.875 225,43	LDSLV3	CR 86543
8.750 222,25	1.500 38,10	8.938 227,03	LDSLV3	CR 87196
8.812 223,82	2.000 50,80	9.000 228,60	LDSLV4	CR 86551
8.813 223,85	1.000 25,40	9.001 228,63	LDSLV3	CR 85688
8.866 225,20	2.500 63,50	9.054 229,97	LDSLV4	CR 87166
8.867 225,22	1.000 25,40	9.055 230,00	LDSLV4	CR 87462
8.875 225,43	1.250 31,75	9.063 230,20	LDSLV3	CR 85973
	1.250 31,75	9.063 230,20	LDSLV4	CR 87526
8.938 227,03	2.500 63,50	9.126 231,80	LDSLV4	CR 86546

Shaft diameter d_1	Sleeve width b	Reference sleeve installed outside diameter	Design	Designation
in./mm	in./mm	in./mm	–	–
9.000 228,60	1.000 25,40	9.188 233,38	LDSL43	CR 87555
9.055 230,00	1.000 25,40	9.243 234,77	LDSL43	CR 89943
9.063 230,20	1.500 38,10	9.251 234,98	LDSL44	CR 85931
9.125 231,78	1.000 25,40	9.313 236,55	LDSL44	CR 86547
	1.500 38,10	9.313 236,55	LDSL44	CR 90130
9.250 234,95	0.875 22,23	9.438 239,73	LDSL44	CR 84643
9.260 235,20	1.102 27,99	9.448 239,98	LDSL44	CR 87789
9.313 236,55	1.500 38,10	9.501 241,33	LDSL43	CR 85377
9.449 240,00	1.181 30,00	9.637 244,78	LDSL44	CR 87144
9.500 241,30	2.500 63,50	9.688 246,08	LDSL44	CR 86562
	1.000 25,40	9.688 246,08	LDSL43	CR 86633
9.563 242,90	1.000 25,40	9.751 247,68	LDSL44	CR 85073
	2.000 50,80	9.751 247,68	LDSL44	CR 85397
9.750 247,65	1.438 36,53	9.938 252,43	LDSL44	CR 84965
	2.250 57,15	9.938 252,43	LDSL44	CR 85045
9.813 249,25	1.125 28,58	10.001 254,03	LDSL44	CR 86413
	2.000 50,80	10.001 254,03	LDSL43	CR 84156
9.835 249,81	1.575 40,01	10.023 254,58	LDSL44	CR 90773
10.000 254,00	1.000 25,40	10.188 258,78	LDSL43	CR 90070
10.063 255,60	2.250 57,15	10.251 260,38	LDSL44	CR 86000
10.188 258,78	1.125 28,58	10.376 263,55	LDSL44	CR 84962
10.240 260,00	1.970 50,00	10.424 264,77	LDSL43	CR 87738
10.313 261,95	2.000 50,80	10.501 266,73	LDSL44	CR 85629
	2.250 57,15	10.501 266,73	LDSL43	CR 85191
10.441 265,20	2.165 54,99	10.629 269,98	LDSL44	CR 86798

Wear sleeves for heavy industrial applications – LDSLV3 and LDSLV4 – inch dimensions
 d_1 10.500 – 12.598 in.

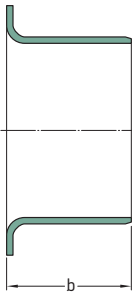

LDSLV3

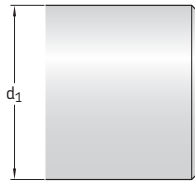

LDSLV4

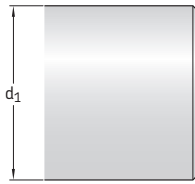

Shaft diameter	Sleeve width	Reference sleeve installed outside diameter	Design	Designation
d_1	b			
in./mm	in./mm	in./mm	–	–
10.500 266,70	2.750 69,85	10.688 271,48	LDSLV4	CR 86013
10.557 268,15	2.250 57,15	10.745 272,92	LDSLV4	CR 85491
10.562 268,27	0.984 24,99	10.750 273,05	LDSLV4	CR 90800
	1.750 44,45	10.750 273,05	LDSLV4	CR 86468
	1.813 46,05	10.750 273,05	LDSLV4	CR 86544
10.563 268,30	1.500 38,10	10.751 273,08	LDSLV4	CR 87768
10.750 273,05	2.500 63,50	10.938 277,83	LDSLV4	CR 86435
10.813 274,65	1.000 25,40	11.001 279,43	LDSLV3	CR 81389
	2.000 50,80	11.001 279,43	LDSLV4	CR 85033
10.846 275,49	0.709 18,01	11.034 280,26	LDSLV4	CR 86601
10.875 276,23	2.000 50,80	11.063 281,00	LDSLV4	CR 84510
11.000 279,40	1.500 38,10	11.188 284,18	LDSLV4	CR 86486
	2.500 63,50	11.188 284,18	LDSLV4	CR 86454
11.024 280,00	1.181 30,00	11.212 284,78	LDSLV4	CR 87142
11.031 280,19	1.260 32,00	11.219 284,96	LDSLV4	CR 87525

Shaft diameter d_1	Sleeve width b	Reference sleeve installed outside diameter	Design	Designation
in./mm	in./mm	in./mm	–	–
11.062 280,97	1.750 44,45	11.250 285,75	LDSL4	CR 85469
11.187 284,15	1.250 31,75	11.375 288,93	LDSL4	CR 86269
11.188 284,18	2.250 57,15	11.376 288,95	LDSL4	CR 85212
11.190 284,23	2.250 57,15	11.378 289,00	LDSL4	CR 87566
11.313 287,35	1.500 38,10	11.501 292,13	LDSL4	CR 84094
11.375 288,93	2.250 57,15	11.563 293,70	LDSL4	CR 86145
11.417 290,00	1.750 44,45	11.605 294,77	LDSL4	CR 86441
11.500 292,10	0.750 19,05	11.688 296,88	LDSL4	CR 90761
11.562 293,67	1.000 25,40	11.750 298,45	LDSL4	CR 90333
11.623 295,22	1.417 35,99	11.811 300,00	LDSL3	CR 87875
11.750 298,45	2.375 60,33	11.938 303,23	LDSL3	CR 87872
11.812 300,02	1.125 28,58	12.000 304,80	LDSL4	CR 86687
11.813 300,05	1.500 38,10	12.001 304,83	LDSL4	CR 85979
	2.250 57,15	12.001 304,83	LDSL3	CR 84819
	2.750 69,85	12.001 304,83	LDSL4	CR 85844
11.969 304,00	0.709 18,00	12.157 308,79	LDSL4	CR 86600
12.000 304,80	2.250 57,15	12.188 309,58	LDSL4	CR 85577
	2.250 57,15	12.188 309,58	LDSL3	CR 87406
12.063 306,40	0.625 15,88	12.251 311,18	LDSL4	CR 85418
	2.500 63,50	12.251 311,18	LDSL3	CR 86404
12.312 312,72	1.500 38,10	12.500 317,50	LDSL4	CR 90174
12.313 312,75	0.750 19,05	12.501 317,53	LDSL4	CR 83760
12.500 317,50	2.125 53,98	12.688 322,28	LDSL3	CR 86169
12.598 320,00	0.984 25,00	12.786 324,76	LDSL3	CR 87434

Wear sleeves for heavy industrial applications – LDSLV3 and LDSLV4 – inch dimensions
d₁ 12.750 – 16.813 in.

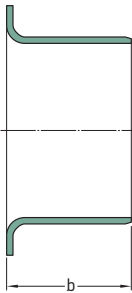

LDSLV3

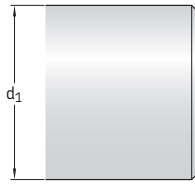

LDSLV4

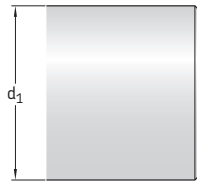

Shaft diameter	Sleeve width	Reference sleeve installed outside diameter	Design	Designation
d ₁	b			
in./mm	in./mm	in./mm	–	–
12.750	0.688	12.938	LDSLV4	CR 87513
323,85	17,48	328,63		
	1.125	12.938	LDSLV3	CR 82099
	28,58	328,63		
	1.500	12.938	LDSLV3	CR 90143
	38,10	328,63		
12.813	1.000	13.001	LDSLV4	CR 86258
325,45	25,40	330,23		
	1.375	13.001	LDSLV4	CR 84263
	34,93	330,23		
	2.000	13.001	LDSLV3	CR 84390
	50,80	330,23		
	2.500	13.001	LDSLV4	CR 86722
	63,50	330,23		
13.000	1.750	13.188	LDSLV4	CR 85535
330,20	44,45	334,98		
13.063	1.125	13.251	LDSLV4	CR 84963
331,80	28,58	336,53		
13.313	0.813	13.501	LDSLV4	CR 86688
338,15	20,65	342,93		
	1.500	13.501	LDSLV4	CR 87463
	38,10	342,93		
	2.000	13.501	LDSLV3	CR 85852
	50,80	342,93		
13.813	1.500	14.001	LDSLV3	CR 81390
350,85	38,10	355,63		
	2.000	14.001	LDSLV4	CR 85179
	50,80	355,63		
14.000	1.375	14.188	LDSLV3	CR 89951
355,60	34,93	360,38		
	1.500	14.188	LDSLV3	CR 81352
	38,10	360,38		
14.173	1.000	14.361	LDSLV4	CR 87445
359,99	25,40	364,77		

Shaft diameter d_1	Sleeve width b	Reference sleeve installed outside diameter	Design	Designation
in./mm	in./mm	in./mm	–	–
14.313 363,55	1.500 38,10	14.501 368,33	LDSL4	CR 86429
14.438 366,73	2.500 63,50	14.626 371,50	LDSL3	CR 86403
14.500 368,30	1.000 25,40	14.688 373,08	LDSL4	CR 85914
14.813 376,25	1.500 38,10	15.001 381,03	LDSL4	CR 87723
	2.125 53,98	15.001 381,03	LDSL3	CR 81391
15.000 381,00	1.000 25,40	15.188 385,78	LDSL4	CR 87247
	0.750 19,05	15.250 387,35	LDSL4	CR 90272
15.066 382,68	1.000 25,40	15.254 387,45	LDSL3	CR 87871
	2.500 63,50	15.376 390,55	LDSL4	CR 87569
15.250 387,35	0.750 19,05	15.438 392,13	LDSL3	CR 84964
	0.906 23,01	15.748 400,00	LDSL4	CR 85582
15.812 401,62	2.500 63,50	16.000 406,40	LDSL3	CR 87634
	2.000 50,80	16.001 406,43	LDSL4	CR 85181
2.000 50,80		16.001 406,43	LDSL3	CR 87446
	2.500 63,50	16.001 406,43	LDSL4	CR 86407
15.998 406,35		2.250 57,15	16.186 411,12	LDSL3
	16.000 406,40	2.000 50,80	16.188 411,18	LDSL3
16.063 408,00		0.500 12,70	16.251 412,78	LDSL4
	1.250 31,75	16.251 412,78	LDSL4	CR 86175
	1.300 33,02	16.251 412,78	LDSL4	CR 86426
	2.000 50,80	16.251 412,78	LDSL4	CR 86575
	2.000 50,80	16.501 419,13	LDSL4	CR 84697
16.750 425,45	1.500 38,10	16.938 430,23	LDSL4	CR 87585
	1.000 25,40	17.000 431,80	LDSL4	CR 86737
16.813 427,05	2.250 57,15	17.001 431,83	LDSL4	CR 84616

Wear sleeves for heavy industrial applications – LDSLV3 and LDSLV4 – inch dimensions
 d_1 17.250 – 25.000 in.

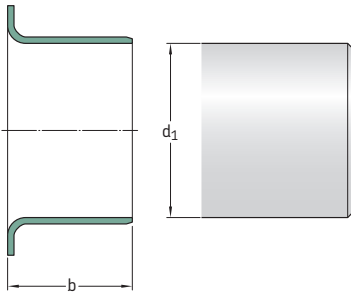

LDSLV3

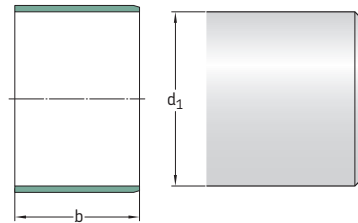

LDSLV4

Shaft diameter	Sleeve width	Reference sleeve installed outside diameter	Design	Designation
d_1	b			
in./mm	in./mm	in./mm	–	–
17.250 438,15	1.000 25,40	17.438 442,93	LDSLV4	CR 90779
	2.000 50,80	17.438 442,93	LDSLV4	CR 84576
17.313 439,75	1.500 38,10	17.501 444,53	LDSLV4	CR 86430
17.449 443,20	2.000 50,80	17.637 447,98	LDSLV4	CR 85762
17.500 444,50	1.250 31,75	17.688 449,28	LDSLV4	CR 90770
17.543 445,59	2.362 59,99	17.731 450,37	LDSLV4	CR 86799
17.750 450,85	1.250 31,75	17.938 455,63	LDSLV4	CR 90774
	2.500 63,50	17.938 455,63	LDSLV3	CR 86631
17.812 452,42	2.125 53,98	18.000 457,20	LDSLV4	CR 87271
17.813 452,45	2.500 63,50	18.001 457,23	LDSLV3	CR 86405
18.163 461,34	2.000 50,80	18.351 466,12	LDSLV4	CR 86343
18.312 465,12	1.191 30,25	18.500 469,90	LDSLV4	CR 90790
18.813 477,85	1.750 44,45	19.001 482,63	LDSLV4	CR 86563
	2.250 57,15	19.001 482,63	LDSLV4	CR 87015
	2.500 63,50	19.001 482,63	LDSLV4	CR 86716

Shaft diameter d_1	Sleeve width b	Reference sleeve installed outside diameter	Design	Designation
in./mm	in./mm	in./mm	–	–
19.496 495,20	2.362 59,99	19.684 499,97	LDSL4	CR 87631
19.497 495,22	1.575 40,01	19.685 500,00	LDSL4	CR 87785
19.500 495,30	1.250 31,75	19.688 500,08	LDSL4	CR 90769
19.563 496,90	2.750 69,85	19.751 501,68	LDSL4	CR 85654
19.813 503,25	1.250 31,75	20.001 508,03	LDSL4	CR 84781
20.312 515,92	1.000 25,40	20.500 520,70	LDSL4	CR 86739
20.813 528,65	1.250 31,75	21.001 533,43	LDSL3	CR 85800
	2.125 53,98	21.001 533,43	LDSL4	CR 85367
	2.500 63,50	21.001 533,43	LDSL4	CR 87298
20.865 529,97	2.250 57,15	21.053 534,75	LDSL4	CR 90805
20.990 533,15	2.250 57,15	21.178 537,92	LDSL3	CR 84579
21.000 533,40	2.250 57,15	21.188 538,18	LDSL4	CR 87090
21.803 553,80	2.362 59,99	21.991 558,57	LDSL4	CR 87069
21.813 554,05	2.250 57,15	22.001 558,83	LDSL4	CR 84590
22.250 565,15	1.000 25,40	22.438 569,93	LDSL3	CR 85691
22.303 566,50	2.362 59,99	22.491 571,27	LDSL4	CR 87070
22.313 566,75	1.250 31,75	22.501 571,53	LDSL4	CR 85907
22.812 579,42	2.000 50,80	23.000 584,20	LDSL4	CR 90163
23.000 584,20	2.000 50,80	23.188 588,98	LDSL4	CR 90146
23.434 595,22	0.984 24,99	23.622 600,00	LDSL4	CR 87777
23.687 601,65	1.950 49,53	23.875 606,43	LDSL4	CR 87907
23.812 604,82	0.750 19,05	24.000 609,60	LDSL4	CR 87922
	2.500 63,50	24.000 609,60	LDSL4	CR 87960
25.000 635,00	2.500 63,50	25.188 639,78	LDSL4	CR 86567

Wear sleeves for heavy industrial applications – LDSLV3 and LDSLV4 – inch dimensions
 d_1 25.312 – 42.500 in.

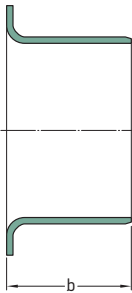

LDSLV3

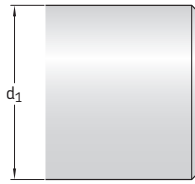

LDSLV4

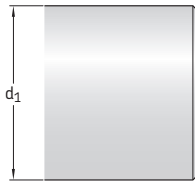

Shaft diameter	Sleeve width	Reference sleeve installed outside diameter	Design	Designation
d_1	b			
in./mm	in./mm	in./mm	–	–
25.312 642,92	2.000 50,80	25.500 647,70	LDSLV4	CR 86091
25.313 642,95	2.500 63,50	25.501 647,73	LDSLV4	CR 87802
26.000 660,40	2.250 57,15	26.188 665,18	LDSLV3	CR 86640
26.312 668,32	1.375 34,93	26.500 673,10	LDSLV4	CR 90809
26.813 681,05	1.250 31,75	27.001 685,83	LDSLV4	CR 85384
	2.250 57,15	27.001 685,83	LDSLV4	CR 85531
27.000 685,80	2.000 50,80	27.188 690,58	LDSLV4	CR 86841
27.063 687,40	2.250 57,15	27.251 692,18	LDSLV4	CR 84764
27.313 693,75	2.250 57,15	27.501 698,53	LDSLV4	CR 85011
27.500 698,50	2.250 57,15	27.688 703,28	LDSLV4	CR 84711
27.812 706,42	2.500 63,50	28.000 711,20	LDSLV4	CR 87421
28.312 719,12	2.313 58,75	28.500 723,90	LDSLV3	CR 87623
28.813 731,85	2.250 57,15	29.001 736,63	LDSLV4	CR 84641
29.813 757,25	2.250 57,15	30.001 762,03	LDSLV4	CR 84642

Shaft diameter d_1	Sleeve width b	Reference sleeve installed outside diameter	Design	Designation
in./mm	in./mm	in./mm	–	–
30.000 762,00	2.500 63,50	30.188 766,78	LD SLV3	CR 86641
30.309 769,85	1.375 34,93	30.497 774,62	LD SLV4	CR 87530
30.312 769,92	2.500 63,50	30.500 774,70	LD SLV3	CR 87842
30.813 782,65	2.000 50,80	31.001 787,43	LD SLV4	CR 85039
31.812 808,02	2.500 63,50	32.000 812,80	LD SLV4	CR 90810
32.313 820,75	2.000 50,80	32.501 825,53	LD SLV4	CR 86090
32.812 833,42	2.220 56,39	33.000 838,20	LD SLV4	CR 87850
33.313 846,15	2.625 66,68	33.501 850,93	LD SLV4	CR 84730
34.312 871,52	1.750 44,45	34.500 876,30	LD SLV4	CR 87529
35.313 896,95	2.500 63,50	35.501 901,73	LD SLV4	CR 85814
35.812 909,62	1.500 38,10	36.000 914,40	LD SLV4	CR 90332
36.375 923,93	2.500 63,50	36.563 928,70	LD SLV4	CR 86111
36.813 935,05	2.500 63,50	37.001 939,83	LD SLV4	CR 86458
37.813 960,45	1.500 38,10	38.001 965,23	LD SLV4	CR 86973
38.000 965,20	1.500 38,10	38.188 969,98	LD SLV4	CR 86840
38.500 977,90	1.500 38,10	38.688 982,68	LD SLV4	CR 81753
38.813 985,85	2.125 53,98	39.001 990,63	LD SLV4	CR 85123
39.813 1011,25	2.125 53,98	40.001 1016,03	LD SLV4	CR 81826
41.312 1049,32	1.968 49,99	41.500 1054,10	LD SLV4	CR 89948
42.063 1068,40	2.125 53,98	42.251 1073,18	LD SLV4	CR 85038
42.125 1069,98	2.125 53,98	42.313 1074,75	LD SLV4	CR 87054
42.312 1074,72	1.250 31,75	42.500 1079,50	LD SLV4	CR 87379
42.500 1079,50	1.250 31,75	42.688 1084,28	LD SLV4	CR 87392

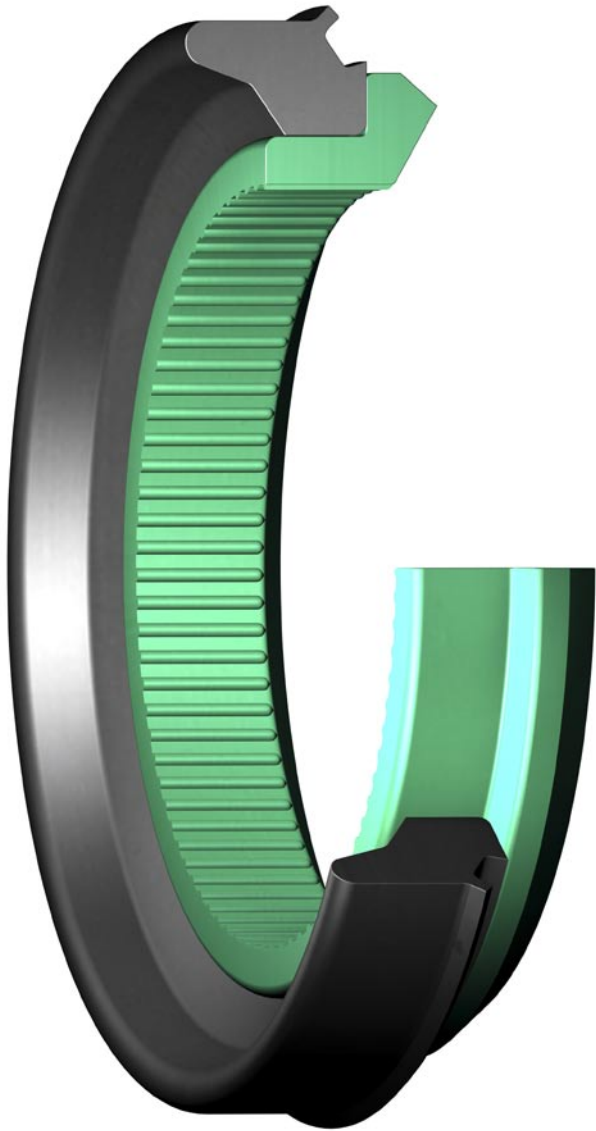

Track pin seals

General	378
Features and benefits	378
5.1 Product table: TP and TPM	380

Track pin seals

General

The SKF track pin seals, SKF Trackstar, are specifically designed for oil lubricated track chains in off-highway applications. The seals are installed on the pin that connects a pair of links in the chain (→ fig. 1).

Features and benefits

The basic SKF Trackstar seal design features a polyurethane sealing ring and a nitrile rubber energizer (→ fig. 2). The sealing ring retains the oil between the pin and the bushing and excludes contaminants. The energizer provides the static sealing ability. Ribs on the seal inside diameter enable oil to pass to provide the necessary lubrication.

There is also a heavy-duty version designed with a metal reinforcement ring moulded into the polyurethane sealing ring, providing additional rigidity for severe operating conditions (→ fig. 3).

Both SKF Trackstar designs are installed on a spacer ring provided by the undercarriage manufacturer. The function of the spacer ring is to ensure that the required space for the seal exists when squeezed between the link and the bushing. The spacer is designed with oil galleys that enable oil to pass for optimal lubrication of the main sealing lip.

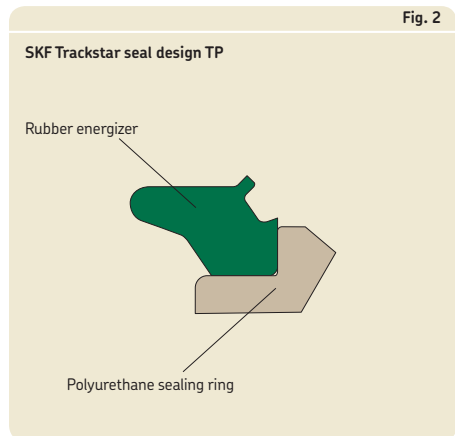
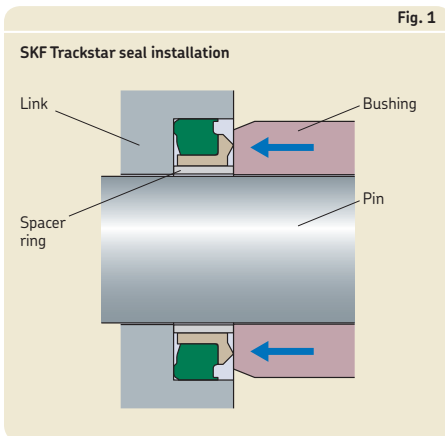

SKF Trackstar seals provide several important benefits including:

- extended service life of the undercarriage
- reduced internal bushing and pin wear
- easy installation
- interchangeability with the most commonly used sealed and lubricated track pin seals

Fig. 3

SKF Trackstar seal design TPM

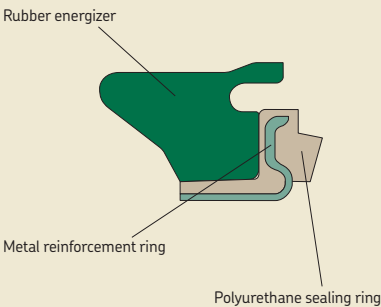

SKF Trackstar seals –TP and TPM – metric dimensions

d_1 33,22 – 80,72 mm

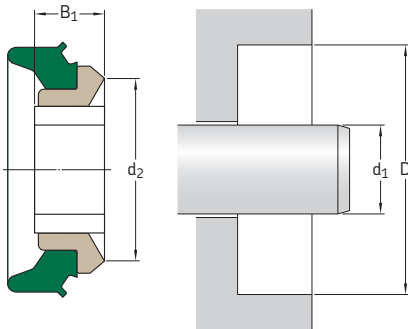

Dimensions Spacer ring outside diameter d_1 max	Bore diameter, nominal D		Operating width B_1		Lip diameter d_2 max	Designation
mm/in.						–
33,22 1.308	47,88 1.885	$\pm 0,25$ ± 0.010	8,38 0.330	$\pm 0,25$ ± 0.010	40,01 1.575	CR 33.2×47.3×11.8 TP
36,47 1.436	51,99 2.047	$\pm 0,25$ ± 0.010	8,31 0.327	$\pm 0,25$ ± 0.010	44,45 1.750	CR 36.5×51.4×11.7 TP
38,05 1.498	55,04 2.167	$\pm 0,25$ ± 0.010	9,60 0.378	$\pm 0,25$ ± 0.010	46,99 1.850	CR 38.1×54.4×12.8 TP
41,86 1.648	59,77 2.353	$\pm 0,25$ ± 0.010	9,25 0.364	$\pm 0,25$ ± 0.010	50,04 1.970	CR 42.0×59.1×12.8 TP
42,52 1.674	59,79 2.354	$\pm 0,03$ ± 0.001	10,69 0.421	$\pm 0,25$ ± 0.010	51,05 2.010	CR 43.1×59.4×14.3 TPM
44,60 1.756	63,04 2.482	$\pm 0,25$ ± 0.010	10,69 0.421	$\pm 0,25$ ± 0.010	53,70 2.114	CR 44.7×62.7×14.2 TP
46,20 1.819	64,64 2.545	$\pm 0,15$ ± 0.006	10,80 0.425	$\pm 0,25$ ± 0.010	56,41 2.221	CR 46.1×64.1×14.1 TP
45,69 1.799	62,99 2.480	$\pm 0,03$ ± 0.001	10,69 0.421	$\pm 0,25$ ± 0.010	54,71 2.154	CR 46.3×62.3×14.3 TPM
50,29 1.980	67,59 2.661	$\pm 0,25$ ± 0.010	10,80 0.425	$\pm 0,25$ ± 0.010	58,42 2.300	CR 50.3×67.0×14.7 TP
52,60 2.071	70,79 2.787	$\pm 0,25$ ± 0.010	10,80 0.425	$\pm 0,25$ ± 0.010	61,34 2.415	CR 52.7×70.5×14.2 TP
52,43 2.064	70,10 2.760	$\pm 0,03$ ± 0.001	10,80 0.425	$\pm 0,25$ ± 0.010	61,11 2.406	CR 53.0×69.3×14.2 TPM
54,99 2.165	72,75 2.864	$\pm 0,25$ ± 0.010	10,80 0.425	$\pm 0,25$ ± 0.010	64,19 2.527	CR 54.9×72.4×14.8 TP
58,19 2.291	75,54 2.974	$\pm 0,25$ ± 0.010	10,67 0.420	$\pm 0,25$ ± 0.010	67,03 2.639	CR 58.1×75.0×14.7 TP
58,90 2.319	77,65 3.057	$\pm 0,25$ ± 0.010	11,10 0.437	$\pm 0,25$ ± 0.010	67,59 2.661	CR 58.8×77.1×15.2 TP

Dimensions Spacer ring outside diameter d_1 max	Bore diameter, nominal D	Operating width B_1	Lip diameter d_2 max	Designation
mm/in.				–
61,09 2.405	82,55 ± 0,13 3.250 ± 0.005	11,10 ± 0,25 0.437 ± 0.010	70,00 2.756	CR 61.1×82.0×16.0 TP
63,14 2.486	83,74 ± 0,25 3.297 ± 0.010	15,49 ± 0,25 0.610 ± 0.010	73,66 2.900	CR 63.2×83.1×19.3 TP
63,60 2.504	83,49 ± 0,25 3.287 ± 0.010	11,13 ± 0,25 0.438 ± 0.010	74,22 2.922	CR 63.6×82.5×15.0 TP
67,21 2.646	87,25 ± 0,25 3.435 ± 0.010	11,13 ± 0,25 0.438 ± 0.010	77,14 3.037	CR 67.1×86.7×15.4 TP
76,71 3.020	99,80 ± 0,13 3.929 ± 0.005	11,10 ± 0,25 0.437 ± 0.010	89,08 3.507	CR 76.7×99.3×15.1 TP
80,72 3.178	106,20 ± 0,13 4.181 ± 0.005	11,10 ± 0,25 0.437 ± 0.010	92,53 3.643	CR 80.8×105.8×15.9 TP

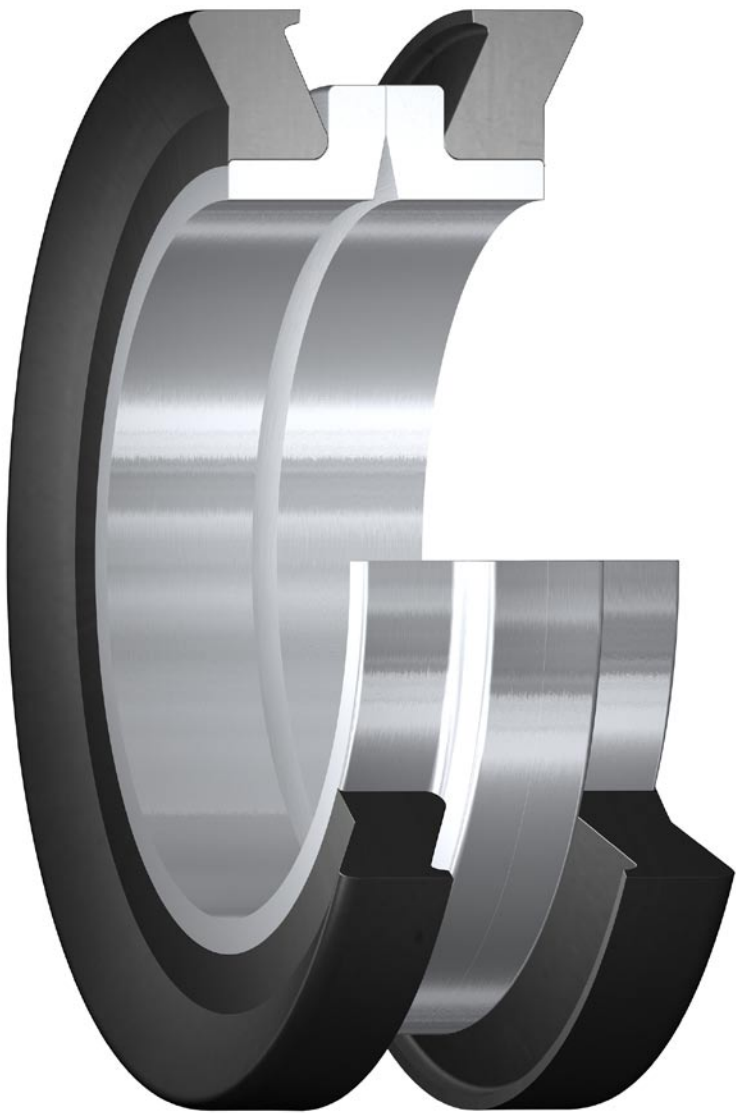

Metal face seals

General	384
Design features	384
Lubricant requirements	385
Permissible operating conditions	386
Contaminants	386
Installing HDDF seals	386
General	386
Housing and seal preparation	386
Installation procedure	387
6.1 Product table: HDDF	388

Metal face seals

General

SKF metal face seals type HDDF (→ **fig. 1**) are designed for use under severe service conditions at relatively low circumferential speeds. They offer reliable protection against solid and liquid contaminants as well as leak-proof retention of lubricants. The seals were originally developed for off-road and tracked vehicles, but have been found to be equally suitable for a range of other applications where effective protection is required against sand, soil, mud, water etc. (→ **fig. 2**). These applications include:

- all types of mixers
- sand treatment equipment
- conveyors and other construction equipment
- agricultural machinery
- washing equipment
- grinding mills and other pulverizing equipment
- ore dressing equipment
- mining equipment

Design features

HDDF seals consist of two identical metal sealing rings and two similar Belleville washers (cup springs) made of nitrile or fluoro rubber compounds, specifically developed for these seals (→ **fig. 3 on page 387**). The sealing rings are made of wear- and corrosion-resistant cast alloy and have finely finished sliding and sealing surfaces.

The Belleville washers of nitrile or fluoro rubber provide the necessary uniform face loading and effective sealing at the bore and outside diameters. The outside diameter of the washers adapts to the form of the bore in which they are installed. It is critical that the bore diameter and bore depth are in accordance with the dimensions listed in the product table on **pages 388 to 391**. Adequate tolerances between the seal assembly and its mating component are critical to ensure a proper sealing performance.

Fig. 1

HDDF seal

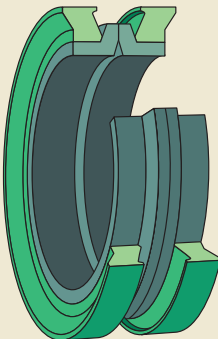

Lubricant requirements

A lubricant should be applied on the dynamic sealing surfaces of a metal face seal to prevent scoring and cover at least 30% of the sealing surface to properly lubricate and cool the sealing rings. The lubricant can be either a detergent like SAE 10W-40 or a mineral based oil ranging from 10 WT to 90 WT, depending on the ambient temperature. It should be noted that some oils contain additives that make them incompatible with elastomers, which can cause degradation of the Belleville washers, especially when exposed to elevated temperatures.

Although mineral oils are always the recommended lubricant, a grease lubricant can also be used in some slowly rotating or oscillating applications, where the seal face surface speed does not exceed 0,5 m/s (100 ft/min). At higher speeds, an oil lubricant is required, not only to provide lubrication to the sealing faces, but also to cool the sealing rings.

Fig. 2

6

HDDF application

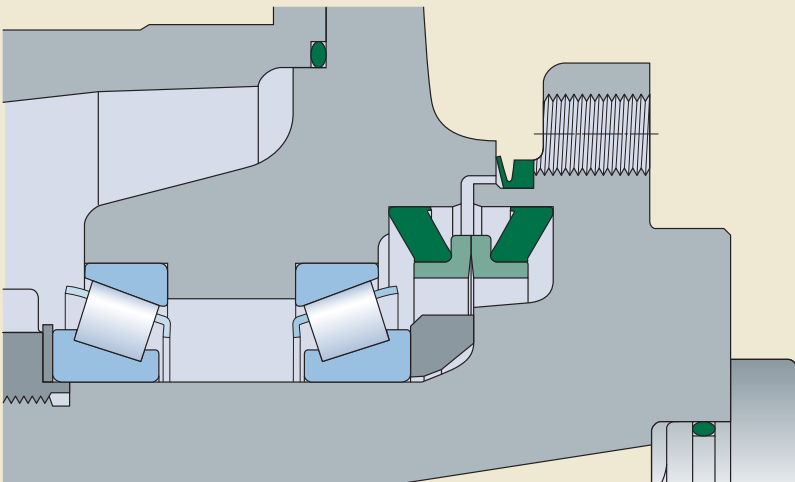

Permissible operating conditions

Depending on their design, metal face seals can withstand different amounts of internal pressure. It should, however, generally be maintained below 0,25 MPa (35 psi). Other recommendations regarding operating conditions for the metal face seals, like temperature and speed, are provided in **table 1**.

The chemical resistance of the nitrile and fluoro rubber in general is dealt with in the section *Chemical resistance* on **page 35**.

Contaminants

Metal face seals are often used in heavily contaminated environments, where mud packing in the cavity between the housing, sealing rings and Belleville washers can occur. Eventually, the mud packing can cause the Belleville washers to be pushed out of position, resulting in improper face loads or mud being pumped past the Belleville washers.

Contaminants can also cause abrasion to the Belleville washers, which in turn causes deterioration of the elastomer. To minimize the risk of seal failure due to this deterioration, it is critical to select a proper Belleville washer material for the application in question.

Installing HDDF seals

General

Careful handling and installation of a metal face seal is critical to avoid cutting or tearing of the elastomeric Belleville washers or breaking the metal sealing rings, both which can cause premature seal failure and immediate leakage. It is also vital to keep the sealing faces free from contaminants like dirt or lint. Always carefully observe installation instructions provided on **page 387**.

Housing and seal preparation

All housing components contacting the Belleville washers must be free from contaminants (oil, grease, dust, lint particles etc.) when installing the seal. SKF recommends using a non-petroleum based solvent and a clean, lint-free wipe to clean these components prior to installation.

All seal parts must be handled with care to avoid damage or scoring.

Table 1

Permissible operating conditions		
Operating condition	Recommended value	
Temperature, max		
Continuous operation		
Nitrile rubber (NBR)	-25 to +100 °C	(-15 to +210 °F)
Fluoro rubber (FKM)	-10 to +190 °C	(15 to 375 °F)
Circumferential speed, max		
Continuous operation	1,8 m/s	(350 ft/min)
Brief periods	3,8 m/s	(750 ft/min)
Pressure, max		
Continuous operation	0,25 MPa	(35 psi)
Brief periods	0,35 MPa	(50 psi)

Installation procedure

- 1 Install the Belleville washers seated against the inside shoulder of the metal sealing rings (→ fig. 4a).
- 2 Carefully push each seal half (Belleville washer and metal sealing ring) into the housing until it is fully seated. Check that the seal is not cocked and that the washers are seated evenly at the bottom of the housing bore. Improper seal installation can result in uneven face loads around the circumference of the seal faces, causing scoring or the sealing rings to separate and allow oil to leak.
- 3 Clean both metal sealing ring faces with a lint-free wipe and apply a thin film of oil. Ensure that no oil is applied to any surface but the sealing ring faces (→ fig. 4b).
- 4 Check that both housings are concentric and in correct alignment. The Belleville washers must not unseat from the bottom of the housing.
- 5 Carefully bring the two housings together, avoiding high impact that can scratch or break the seal components.
- 6 Finally, hold one half of the assembly stationary while rotating the other half at least ten complete revolutions.

NOTE: This procedure enables the installer to check that the housing and the Belleville washers are aligned. If the seal assembly wobbles, it is necessary to disassemble it and make sure that the Belleville washers are properly seated in the housing.

Fig. 3

Design features

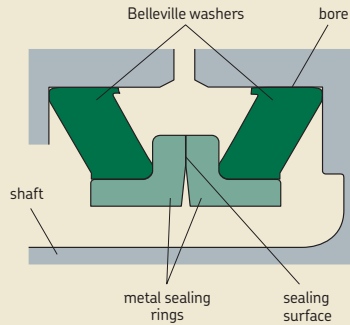
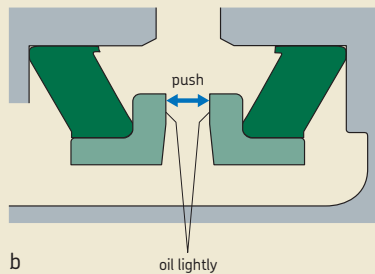
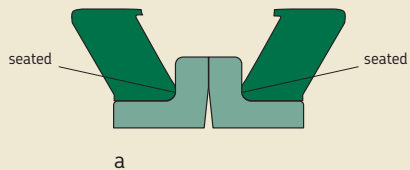

Fig. 4

Installation procedure



Metal face seals – HDDF – inch and metric dimensions

d_1 1.688 – 7.800 in.

d_1 42,88 – 198,12 mm

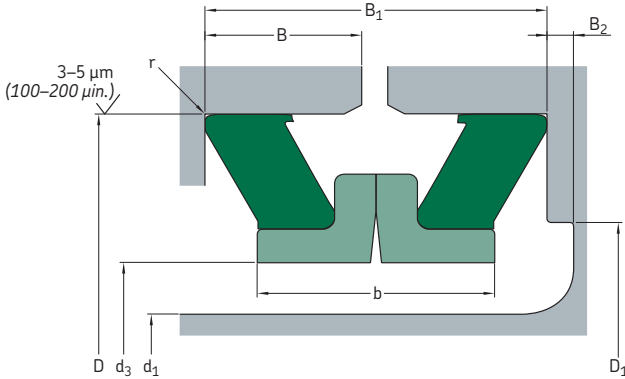

Designation	Lip material	Inch dimensions		Operating width B_1	Seal inside diameter ¹⁾ d_3 min	Bore depth B	Recommended shoulder diameter D_1 max	min ²⁾	Undercut B_2 min	Sealing ring width b max	Radius r max
		Shaft diameter d_1 max	Bore diameter D								
–	–	in.									
CR 16904	R	1.688	2.760 ±0.002	0.974 ±0.038	1.760	0.453	2.282	–	–	0.846	0.037
CR 18259	R	1.812	3.003 ±0.002	0.892 ±0.031	1.910	0.416	2.475	–	–	0.790	0.042
CR 21306	R	2.125	3.250 ±0.002	0.900 ±0.033	2.215	0.418	2.759	–	–	0.812	0.045
CR 25096	R	2.500	3.762 ±0.002	0.907 ±0.033	2.580	0.422	3.188	–	–	0.840	0.042
CR 27536	R	2.750	4.030 ±0.002	0.918 ±0.035	2.830	0.426	3.480	–	–	0.810	0.042
CR 30651	R	3.063	4.500 ±0.002	1.016 ±0.035	3.170	0.475	3.833	–	–	0.912	0.042
CR 35076	R	3.500	4.953 ±0.002	1.096 ±0.043	3.620	0.511	4.296	–	–	0.962	0.035
CR 38740	R	3.875	5.312 ±0.003	1.102 ±0.024	4.040	0.524	4.750	–	–	1.002	0.042
CR 38751	R	3.875	5.562 ±0.003	1.267 ±0.050	4.040	0.594	4.791	–	–	1.110	0.051
CR 43135	R	4.312	5.823 ±0.003	1.102 ±0.024	4.420	0.524	5.125	–	–	1.002	0.042
CR 43150	R	4.312	6.000 ±0.003	1.320 ±0.040	4.420	0.625	5.173	–	–	1.090	0.051
CR 46975	R	4.688	6.400 ±0.003	1.525 ±0.050	4.795	0.722	5.583	–	–	1.254	0.047
CR 50655	R	5.062	6.750 ±0.003	1.280 ±0.040	5.170	0.605	5.975	–	–	1.150	0.057
CR 54000	R	5.400	6.990 ±0.003	1.310 ±0.030	5.625	0.625	6.625	–	–	1.182	0.057
CR 56170	R	5.625	7.250 ±0.003	1.366 ±0.031	5.825	0.650	6.486	6.174	0.032	1.300	0.057
CR 58775	R	5.875	7.641 ±0.003	1.510 ±0.031	6.000	0.724	6.868	6.548	0.056	1.490	0.073
CR 63796	R	6.375	8.120 ±0.003	1.265 ±0.040	6.570	0.598	7.555	7.505	0.125	1.350	0.042
CR 67560	R	6.750	8.620 ±0.004	1.375 ±0.030	6.920	0.656	7.750	–	–	1.260	0.042
CR 74310	R	7.438	9.400 ±0.004	1.656 ±0.040	7.540	0.793	8.431	–	–	1.344	0.073
CR 78020	R	7.800	10.000 ±0.004	1.750 ±0.050	7.940	0.835	8.910	–	–	1.500	0.058

¹⁾ Reference dimension

²⁾ Applicable when b is greater than B, requiring an undercut B_2

Designation	Lip material	Metric dimensions		Operating width B ₁	Seal inside diameter ¹⁾ d ₃ min	Bore depth B	Recommended shoulder diameter		Undercut B ₂ min	Sealing ring width b max	Radius r max
		Shaft diameter d ₁ max	Bore diameter D				D ₁ max	min ²⁾			
–	–	mm									
CR 16904	R	42,88	70,10 ±0,06	24,74 ±0,97	44,70	11,51	57,96	-	-	21,49	0,94
CR 18259	R	46,03	76,28 ±0,06	22,66 ±0,79	48,51	10,57	62,87	-	-	20,07	1,07
CR 21306	R	53,98	82,55 ±0,06	22,86 ±0,84	56,26	10,62	70,08	-	-	20,62	1,14
CR 25096	R	63,50	95,54 ±0,06	23,04 ±0,84	65,53	10,72	80,98	-	-	21,34	1,07
CR 27536	R	69,85	102,36 ±0,06	23,32 ±0,89	71,88	10,82	88,39	-	-	20,57	1,07
CR 30651	R	77,80	114,30 ±0,06	25,81 ±0,89	80,52	12,07	97,36	-	-	23,16	1,07
CR 35076	R	88,90	125,81 ±0,06	27,84 ±1,09	91,95	12,98	109,12	-	-	24,43	0,89
CR 38740	R	98,43	134,92 ±0,08	27,99 ±0,61	102,62	13,31	120,65	-	-	25,45	1,07
CR 38751	R	98,43	141,27 ±0,08	32,18 ±1,27	102,62	15,09	121,69	-	-	28,19	1,30
CR 43135	R	109,52	147,90 ±0,08	27,99 ±0,61	112,27	13,31	130,18	-	-	25,45	1,07
CR 43150	R	109,52	152,40 ±0,08	33,53 ±1,02	112,27	15,88	131,39	-	-	27,69	1,30
CR 46975	R	119,08	162,56 ±0,08	38,74 ±1,27	121,79	18,34	141,81	-	-	31,85	1,19
CR 50655	R	128,57	171,45 ±0,08	32,51 ±1,02	131,32	15,37	151,77	-	-	29,21	1,45
CR 54000	R	137,16	177,55 ±0,08	33,27 ±0,76	142,88	15,88	168,28	-	-	30,02	1,45
CR 56170	R	142,88	184,15 ±0,08	34,70 ±0,79	147,96	16,51	164,74	156,82	0,81	33,02	1,45
CR 58775	R	149,23	194,08 ±0,08	38,35 ±0,79	152,40	18,39	174,45	166,32	1,42	37,85	1,85
CR 63796	R	161,93	206,25 ±0,08	32,13 ±1,02	166,88	15,19	191,90	190,63	3,18	34,29	1,07
CR 67560	R	171,45	218,95 ±0,10	34,93 ±0,76	175,77	16,66	196,85	-	-	32,00	1,07
CR 74310	R	188,93	238,76 ±0,10	42,06 ±1,02	191,52	20,14	214,15	-	-	34,14	1,85
CR 78020	R	198,12	254,00 ±0,10	44,45 ±1,27	201,68	21,21	226,31	-	-	38,10	1,47

1) Reference dimension

2) Applicable when b is greater than B, requiring an undercut B₂

Metal face seals – HDDF – inch and metric dimensions

d_1 8.250 – 29.000 in.

d_1 209,55 – 736,60 mm

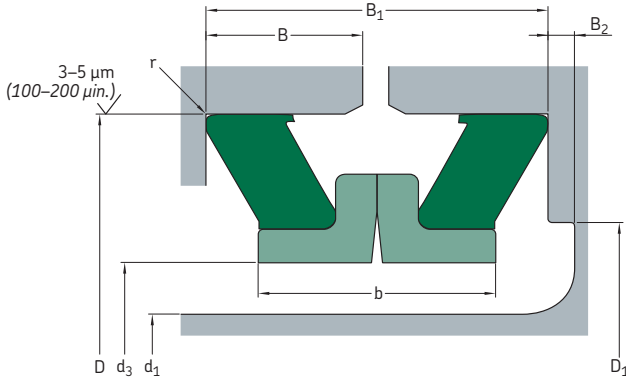

Designation	Lip material	Inch dimensions		Operating width B_1	Seal inside diameter ¹⁾ d_3 min	Bore depth B	Recommended shoulder diameter		Undercut B_2 min	Sealing ring width b max	Radius r max
		Shaft diameter d_1 max	Bore diameter D				D_1 max	min ²⁾			
–	–	in.									
CR 82540	R	8.250	10.062 ±0.004	1.560 ±0.040	8.358	0.745	9.280	9.220	0.071	1.562	0.058
CR 86850	R	8.688	10.911 ±0.005	1.924 ±0.030	8.790	0.932	9.754	–	–	1.642	0.058
CR 93115	R	9.312	11.000 ±0.005	1.437 ±0.032	9.410	0.687	10.360	10.260	0.090	1.510	0.050
CR 93125	R	9.312	11.625 ±0.005	1.754 ±0.050	9.410	0.837	10.750	–	–	1.510	0.089
CR 95620	R	9.562	11.859 ±0.005	1.949 ±0.069	9.660	0.925	10.703	–	–	1.700	0.074
CR 108710	R	10.875	12.969 ±0.005	1.540 ±0.050	11.060	0.730	12.100	12.000	0.143	1.670	0.043
CR 116500	R	11.625	13.250 ±0.005	1.290 ±0.030	11.780	0.615	12.780	–	–	1.210	0.450
CR 124020	R	12.400	14.375 ±0.005	1.656 ±0.050	12.500	0.788	13.530	13.470	0.060	1.610	0.057
CR 137570	R	13.750	15.817 ±0.005	1.875 ±0.032	13.910	0.906	14.985	–	–	1.670	0.089
CR 806715	R	14.750	16.695 ±0.005	1.875 ±0.032	14.950	0.906	15.863	–	–	1.670	0.620
CR 807115	V	14.750	16.695 ±0.005	1.875 ±0.032	14.950	0.906	15.863	–	–	1.670	0.062
CR 171025	R	17.125	19.240 ±0.006	1.531 ±0.053	17.280	0.724	18.400	18.300	0.140	1.659	0.043
CR 191022	R	19.125	21.500 ±0.006	1.640 ±0.042	19.250	0.784	20.950	20.850	0.175	1.832	0.057
CR 238020	R	23.875	26.875 ±0.006	2.125 ±0.040	24.280	1.018	25.550	–	–	1.851	0.089
CR 807199	V	23.875	26.875 ±0.006	2.125 ±0.040	24.280	1.018	25.550	–	–	1.851	0.089
CR 807149	V	29.000	32.000 ±0.006	2.125 ±0.040	29.512	1.028	30.672	–	–	1.851	0.089

¹⁾ Reference dimension

²⁾ Applicable when b is greater than B , requiring an undercut B_2

Designation	Lip material	Metric dimensions		Operating width B ₁	Seal inside diameter ¹⁾ d ₃ min	Bore depth B	Recommended shoulder diameter		Undercut B ₂ min	Sealing ring width b max	Radius r max
		Shaft diameter d ₁ max	Bore diameter D				D ₁ max	min ²⁾			
–	–	mm									
CR 82540	R	209,55	255,57 ±0,10	39,62 ±1,02	212,29	18,92	235,71	234,19	1,80	39,67	1,47
CR 86850	R	220,68	277,14 ±0,13	48,87 ±0,76	223,27	23,67	247,75	–	–	41,71	1,47
CR 93115	R	236,52	279,40 ±0,13	36,50 ±0,81	239,01	17,45	263,14	260,60	2,29	38,35	1,27
CR 93125	R	236,52	295,28 ±0,13	44,55 ±1,27	239,01	21,26	273,05	–	–	38,35	2,26
CR 95620	R	242,87	301,22 ±0,13	49,50 ±1,75	245,36	23,50	271,86	–	–	43,18	1,88
CR 108710	R	276,23	329,41 ±0,13	39,12 ±1,27	280,92	18,54	307,34	304,80	3,63	42,42	1,09
CR 116500	R	295,28	336,55 ±0,13	32,77 ±0,76	299,21	15,62	324,61	–	–	30,73	11,43
CR 124020	R	314,96	365,13 ±0,13	42,06 ±1,27	317,50	20,02	343,66	342,14	1,52	40,89	1,45
CR 137570	R	349,25	401,75 ±0,13	47,63 ±0,81	353,31	23,01	380,62	–	–	42,42	2,26
CR 806715	R	374,65	424,05 ±0,13	47,63 ±0,81	379,73	23,01	402,92	–	–	42,42	15,75
CR 807115	V	374,65	424,05 ±0,13	47,63 ±0,81	379,73	23,01	402,92	–	–	42,42	1,57
CR 171025	R	434,98	488,70 ±0,15	38,89 ±1,35	438,91	18,39	467,36	464,82	3,56	42,14	1,09
CR 191022	R	485,78	546,10 ±0,15	41,66 ±1,07	488,95	19,91	532,13	529,59	4,45	46,53	1,45
CR 238020	R	606,43	682,63 ±0,15	53,98 ±1,02	616,71	25,86	648,97	–	–	47,02	2,26
CR 807199	V	606,43	682,63 ±0,15	53,98 ±1,02	616,71	25,86	648,97	–	–	47,02	2,26
CR 807149	V	736,60	812,80 ±0,15	53,98 ±1,02	749,60	26,11	779,07	–	–	47,02	2,26

¹⁾ Reference dimension

²⁾ Applicable when b is greater than B, requiring an undercut B₂



V-ring seals

General	394
Features	394
Materials	395
Standard designs	396
Main V-ring functions	397
Other V-ring functions	398
Sliding velocities	399
Coaxiality and runout	400
Misalignment	400
Counterface	401
Counterface treatment	401
Additional counterface information	401
Shaft requirements	403
Installing V-rings	403
7.1 Product table: V-ring seals dimensions, for North American market	404
7.2 Product table: V-ring seals dimensions, globally valid outside North American market	432
MVR axial shaft seals	460
General	460
Advantages and user benefits	460
Design and material	460
Temperature range	460
Sizes	460
Installation	461
7.3 Product table: MVR1	462
7.4 Product table: MVR2	464



V-ring seals

General

V-ring seals (or V-rings) are unique all-rubber seals for rotating shafts and are used in an extremely wide range of applications. The V-ring can be used alone to protect a wide assortment of bearing types from contaminants while reliably retaining the lubricant. They are also often used as secondary seals to protect primary seals in highly contaminated environments.

V-rings are installed on shafts and their thin, tapered lip seals against a counterface perpendicular to the shaft (→ **fig. 1a**). V-rings have an interference fit on the shaft, rotate with it and act as flingers (→ **fig. 1b**). Angular misalignment of the shaft relative to the counterface can be tolerated (→ **fig. 1c**). V-rings provide reliable sealing even if the shaft is out-of-round or rotates eccentrically (→ **fig. 1d**). The amount by which the shaft can be displaced axially is governed by the permissible displacement of the V-ring relative to its counterface.

V-rings are made entirely of elastomers without fabric or metal reinforcement and are therefore easy to install. They can be stretched and, depending on size, pushed over other components like flanges, pulleys or even housings. This is a very valuable feature, especially when replacing a seal.

Features

AV-ring consists of a seal body (→ **fig. 2a**), a flexible, conical-shaped sealing lip (→ **fig. 2b**) and an integral, resilient "hinge" (→ **fig. 2c**). It is stretched and installed directly on the shaft, where it is held in place by the inherent tension of the seal body. It rotates with the shaft and seals axially against a stationary counterface.

The counterface can be the end face of a bearing, a washer, stamping, bearing housing, or even the metal case of a radial shaft seal.

The flexible sealing lip applies contact pressure against the counterface that is relatively

Fig. 1

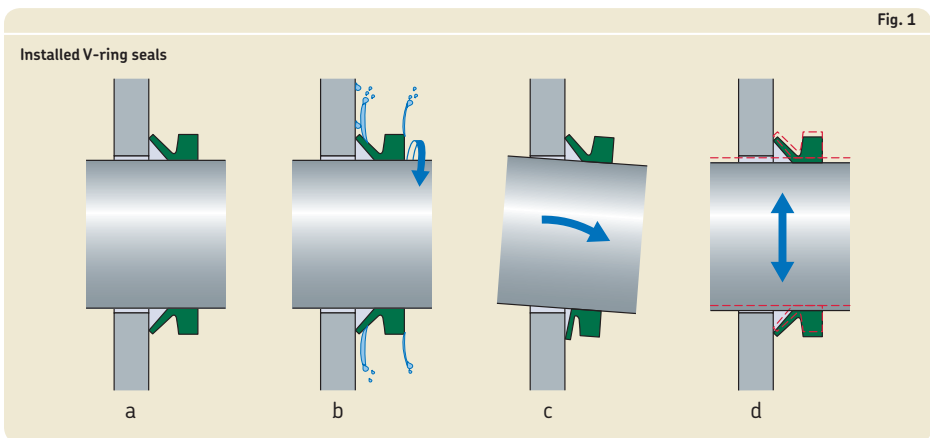

low but sufficient enough to maintain the sealing function. The light contact pressure even enables the seal to run dry in some low-speed applications resulting in insignificant torque drag or heat build-up. The contact pressure varies with the fitted width.

The flexible lip and hinge provide adequate sealing even in applications with considerable end play and shaft misalignment.

As a result of centrifugal force, the contact pressure of the lip decreases as speed increases. This means that friction losses and heat are kept to a minimum, resulting in improved wear resistance and extended service life. The power loss reaches its maximum at a shaft speed of approximately 12 m/s (2 360 ft/min) and is thereafter gradually reduced up to 20 m/s (3 900 ft/min), where it will decrease to zero. The V-ring then serves as a clearance seal and deflector.

Materials

V-rings are normally made of nitrile rubber that features good chemical resistance, resistance to wear and can be used in applications with normal operating temperatures. For applications with higher temperatures or where aggressive media are present, V-rings made of fluoro rubber can be supplied. The permissible operating conditions for V-rings made of nitrile or fluoro rubber are listed in **table 2** on **page 399**. In the product table under the heading *Lip code*, the letters R and V are used to identify nitrile rubber and fluoro rubber respectively.

Fig. 2

V-ring design

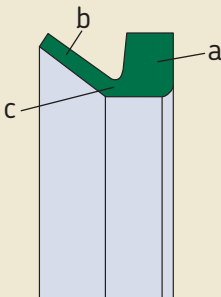

Standard designs

SKF offers five standard V-ring designs:

- VR1/VA, the most common type of V-ring, has a standard cross section and straight back sideface. VR1/VA is typically used to protect bearing arrangements in gearboxes, electric motors and drives.
- VR2/VS, that has a standard low cross section, tapered back face and wide body, providing a firm hold on the shaft. VR2/VS is commonly used in agricultural and automotive applications.
- VR3/VL, designed with a very compact axial cross section. VR3/VL is commonly used in confined spaces to replace labyrinth seals.
- VR5/VRM, a wide, large diameter V-ring with low cross section. VR5/VRM can be located axially and radially on the shaft using a standard band clamp. VR5/VRM has an extension that can be fitted into mechanical components or trimmed to length to meet existing space requirements. VR5/VRM is primarily intended for large, high-speed applications, like rolling mills and paper mills.

- VR6/VRME, a heavy-duty, large diameter V-ring for applications with large axial displacements. VR6/VRME can be located axially and radially on the shaft using a standard band clamp. VR6/VRME is primarily designed to protect high-speed bearing arrangements in rolling mills, paper-making and other large machine applications. The VR6/VRME is similar in shape to the VR5/VRME, except that it does not have the extension to the rear of the body section. It retains the saddle feature for axial and radial location on the shaft with a band clamp. VR6/VRME is available on a made-to-order basis.

V-rings from SKF are available for the shaft diameter ranges listed in **table 1**. If the shaft diameter lies in the appropriate range for two V-rings, the larger V-ring should always be chosen. In addition, special sizes and designs, including split versions, can be made to order. Contact your SKF sales representative for sizes outside the standard range.

Table 1

Standard V-ring designs and size ranges



Design, North America Design, elsewhere	VR1 VA	VR2 VS	VR3 VL	VR5 VRM	VR6 VRME
–	mm (in.)				
min	2.7 0.106	4,5 0.177	105 4.134	450 17.716	300 11.811
max	2 020 79.257	210 8.268	2 025 79.724	2 010 79.134	1 995 78.543

Main V-ring functions

V-rings are suitable for both grease and oil lubricated applications. For sealing grease lubricated bearing arrangements and protecting against contaminants, the V-ring should be arranged outside the housing cover or housing wall. Dust, water spray and other contaminants can be excluded in this position (→ **fig. 3**). The V-ring can also act as a grease valve, where used grease or excess new grease can escape between the counterface and the sealing lip (→ **fig. 4**). The installation of two opposing V-rings can be used in applications where lubricant retention and contaminant exclusion are of equal importance (→ **fig. 5**).

If V-rings are used to retain oil, they should always be located axially on the shaft on the lubricant side (→ **fig. 6**).

V-rings should not be submerged in the application medium.

Fig. 3

V-ring used as an excluder



Fig. 4

V-ring used as a grease valve

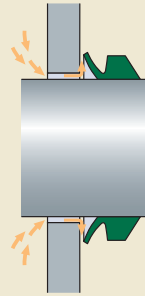

Fig. 5

Two opposing V-rings

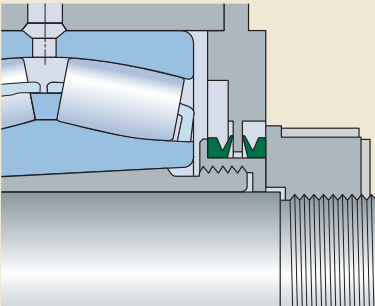
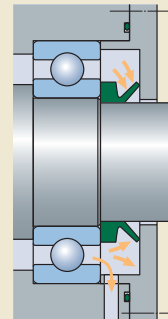

Fig. 6

V-ring located axially



Other V-ring functions

V-rings can also be used as secondary seals (→ **fig. 7**), for example where it is necessary to protect the sealing lip and counterface of the primary seal against contaminants or corrosion and they can be used to enhance the efficiency of labyrinth seals (→ **fig. 8**).

Fig. 7

V-ring used as a secondary seal

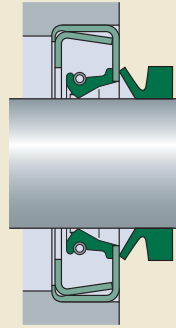
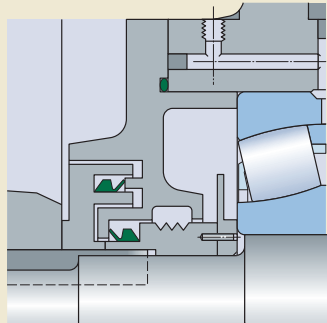

Fig. 8

V-rings in a labyrinth seal



Sliding velocities

V-rings can operate under the conditions listed in **table 2**. In the speed range 15 to 20 m/s (2 900 to 3 900 ft/min), the sealing lip lifts from the counterface and the V-ring only acts as a gap-type seal.

Table 2

Permissible operating conditions



1
normal

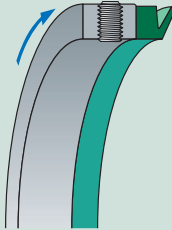

2
located axially¹⁾

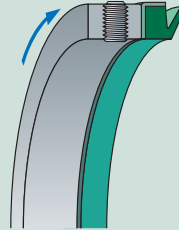

3
axial and radial support¹⁾

Operating conditions

Guideline values for V-rings of nitrile rubber

fluoro rubber

Temperature, °C (°F)

dynamic sealing

static sealing

-40 to +100 (-40 to +210)

-40 to +120 (-40 to +250)

-20 to +150 (-4 to +300)

-40 to +230 (-40 to +445)

Circumferential speed, m/s (ft/min)

normal (1)

located axially (2)

axial and radial support (3)

up to 8 (1 575)

8 to 12 (1 575 to 2 360)

>12 (2 360)

up to 6,5 (1 280)

6,5 to 10 (1 280 to 1 970)

>10 (1 970)

Pressure acting on seal, MPa (psi)

static sealing or very low
speed operation

up to 0,03 (4.35)

up to 0,03 (4.35)

¹⁾ Support ring by customer

Coaxiality and runout

The total tolerance for the deviation from coaxiality and runout should not exceed the guideline values provided in **table 3**.

Misalignment

V-rings can tolerate misalignment between the shaft and housing, i.e. deviations from the perpendicularity between the shaft and counterface of the housing. Guideline values for the maximum permissible angular misalignment are provided in **diagram 1**. These values apply to the V-ring designs VR1/VA and VR2/VS that are supported axially on the shaft.

The permissible misalignment values for the very compact VR3/VL design are appreciably lower than those for the VR1/VA and VR2/VS designs.

In applications where V-rings are not supported axially on the shaft, the maximum value in the diagram should be reduced.

Table 3

Coaxiality and runout tolerances

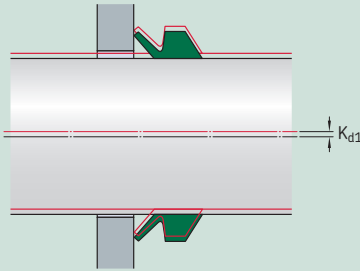

Shaft diameter nominal				Total tolerance for coaxiality deviation and runout	
d_1 over	incl.	over	incl.	K_{d_1} max	
mm		in.		mm	in.
V-rings, VR1/VA and VR2/VS designs					
9,5			0.374	0,4	0.016
9,5	19,5	0.374	0.768	0,6	0.024
19,5	38	0.768	1.496	0,9	0.034
38	68	1.496	2.677	1,1	0.043
68	105	2.677	4.134	1,4	0.055
105	155	4.134	6.102	1,6	0.063
155	210	6.102	8.628	1,9	0.075
210	2 020	8.628	79.527	3,6	0.142
V-rings, VR3/VL designs					
135	630	5.315	24.803	1,5	0.059

Counterface

A fine-turned counterface is adequate for V-rings. The appropriate surface roughness values vary depending on the circumferential speed (→ **table 4** on **page 402**). SKF recommends buffing all turned surfaces with an emery cloth to remove any sharp peaks arising from the turning operation. The surface finish should be measured at approximately 90 degrees to the path of the groove to obtain a true reading of the surface.

Counterface treatment

In the presence of grease, oil or dry lubricants, no special counterface treatment is required. Mild steel counterfaces that are exposed to water or other corrosives should be either zinc-plated or passivated. Chromium- or cadmium-plated shafts should be painted or treated with an anti-corrosive spray.

Additional counterface information

Aluminium surfaces should be free of scratch marks. Surface hardness should be > 100 HB in abrasive applications. Die cast aluminium can be used in the as-cast condition.

Steel and cast iron surfaces should be free from lead and sharp tool marks. Cold roll steel stampings can be used without machining.

Plastic counterface materials are generally not acceptable due to poor heat dissipation.

Stainless steel should not be used in dry-running applications unless the speed is below 1 m/s (200 ft/min).

Diagram 1

Maximum permissible misalignment for V-rings of the VR1/VA and VR2/VS designs

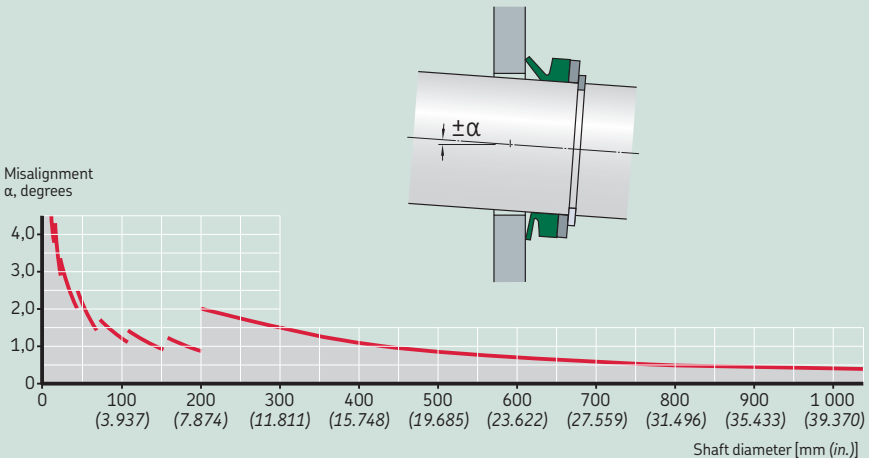

V-ring seals

Table 4

Recommended counterface surface finish

Circumferential speed		Surface finish	
m/s	ft/min.	R _a μm	R _a μin.
> 10	> 1 969	0,4–0,8	16–32
5–10	984–1 969	0,8–1,6	32–64
1–5	199–984	1,6–2,0	64–80
< 1	< 199	2,0–2,5	80–100

The surface finish must not be lower than R_a 0,05 μm (2 μin.).

Shaft requirements

Sharp edges, nicks and burrs on the shaft must be avoided to prevent damage to the V-ring during installation.

V-rings rotate with the shaft and only require a moderate surface roughness value. As a general guideline, the value should not exceed R_a 6,3 μm (252 $\mu\text{in.}$). When sealing fluids or exposed to fine, solid contaminants, the V-ring requires a surface roughness value of maximum R_a 3,2 μm (128 $\mu\text{in.}$).

A V-ring is stretched when installed and fits all shaft diameters within the ranges listed in the product tables.

Installing V-rings

V-rings are elastic and can be stretched and pushed over other components, which facilitates the installation (\rightarrow **fig. 9**). When several V-rings are to be installed, a simple tool (\rightarrow **fig. 10**) can be used to push the seals to their position at a predetermined distance from the counterface. V-rings can also be cut and rejoined in the field.

The general installation guidelines include the following:

- Clean the V-ring, counterface and shaft.
- Make sure that the shaft is dry and free from grease or oil, particularly when installing a V-ring without axial support.
- Lubricate the lip of the V-ring with a thin film of grease or silicone oil.
- In applications where friction must be reduced to a minimum, the counterface should be coated with a low-friction agent. Do not apply grease to the lip.
- Check that the V-ring is installed with a uniform stretch around the shaft.

Fig. 9

Installing a V-ring

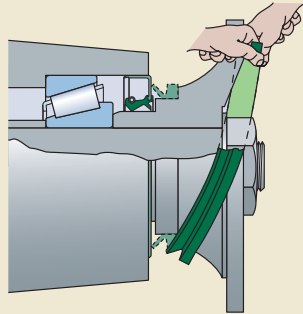
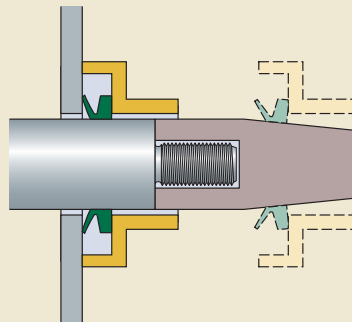

Fig. 10

Installation tool



V-ring seals – metric dimensions, for North American market

d_1 2,7 – 48 mm

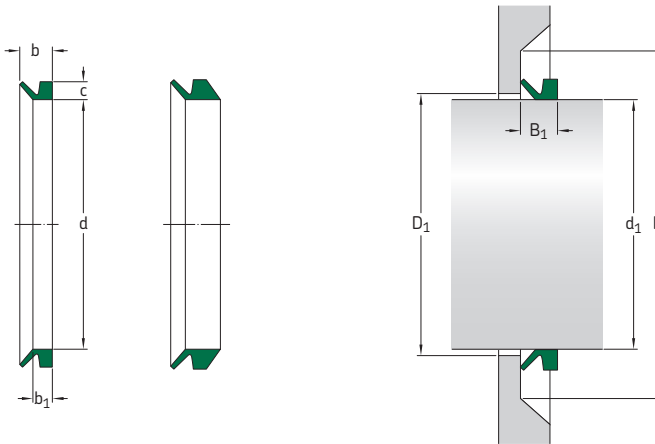

Dimensions		Seal inside diameter, free state d	Seal seat width b_1	Nominal seal width b	Nominal seal height c	Clearance D_1 max	Counterface D min	Seal fitted width B_1	Design	Lip code	Designation code
Shaft diameter range d_1 over	incl.										
mm											
2,7	3,5	2,5	2,1	3	1,5	$d_1 + 1$	$d_1 + 4$	$2,5 \pm 0,3$	VR1	R	CR 400030
		2,5	2,1	3	1,5	$d_1 + 1$	$d_1 + 4$	$2,5 \pm 0,3$	VR1	V	CR 400034
3,5	4,5	3,2	2,4	3,7	2	$d_1 + 1$	$d_1 + 6$	$3,0 \pm 0,4$	VR1	R	CR 400040
		3,2	2,4	3,7	2	$d_1 + 1$	$d_1 + 6$	$3,0 \pm 0,4$	VR1	V	CR 400044
4,5	5,5	4	2,4	3,7	2	$d_1 + 1$	$d_1 + 6$	$3,0 \pm 0,4$	VR1	R	CR 400050
		4	2,4	3,7	2	$d_1 + 1$	$d_1 + 6$	$3,0 \pm 0,4$	VR1	V	CR 400054
		4	3,9	5,2	2	$d_1 + 1$	$d_1 + 6$	$4,5 \pm 0,4$	VR2	R	CR 400051
		4	3,9	5,2	2	$d_1 + 1$	$d_1 + 6$	$4,5 \pm 0,4$	VR2	V	CR 400055
5,5	6,5	5	2,4	3,7	2	$d_1 + 1$	$d_1 + 6$	$3,0 \pm 0,4$	VR1	R	CR 400060
		5	2,4	3,7	2	$d_1 + 1$	$d_1 + 6$	$3,0 \pm 0,4$	VR1	V	CR 400064
		5	3,9	5,2	2	$d_1 + 1$	$d_1 + 6$	$4,5 \pm 0,4$	VR2	R	CR 400061
		5	3,9	5,2	2	$d_1 + 1$	$d_1 + 6$	$4,5 \pm 0,4$	VR2	V	CR 400065
6,5	8,0	6	2,4	3,7	2	$d_1 + 1$	$d_1 + 6$	$3,0 \pm 0,4$	VR1	R	CR 400070
		6	2,4	3,7	2	$d_1 + 1$	$d_1 + 6$	$3,0 \pm 0,4$	VR1	V	CR 400074
		6	3,9	5,2	2	$d_1 + 1$	$d_1 + 6$	$4,5 \pm 0,4$	VR2	R	CR 400071
		6	3,9	5,2	2	$d_1 + 1$	$d_1 + 6$	$4,5 \pm 0,4$	VR2	V	CR 400075
8,0	9,5	7	2,4	3,7	2	$d_1 + 1$	$d_1 + 6$	$3,0 \pm 0,4$	VR1	R	CR 400080
		7	2,4	3,7	2	$d_1 + 1$	$d_1 + 6$	$3,0 \pm 0,4$	VR1	V	CR 400084
		7	3,9	5,2	2	$d_1 + 1$	$d_1 + 6$	$4,5 \pm 0,4$	VR2	R	CR 400081
		7	3,9	5,2	2	$d_1 + 1$	$d_1 + 6$	$4,5 \pm 0,4$	VR2	V	CR 400085
9,5	11,5	9	3,4	5,5	3	$d_1 + 1$	$d_1 + 9$	$4,5 \pm 0,6$	VR1	R	CR 400100
		9	3,4	5,5	3	$d_1 + 1$	$d_1 + 9$	$4,5 \pm 0,6$	VR1	V	CR 400104
		9	5,6	7,7	3	$d_1 + 1$	$d_1 + 9$	$6,7 \pm 0,6$	VR2	R	CR 400101
		9	5,6	7,7	3	$d_1 + 1$	$d_1 + 9$	$6,7 \pm 0,6$	VR2	V	CR 400105
11,5	12,5	10,5	3,4	5,5	3	$d_1 + 1$	$d_1 + 9$	$4,5 \pm 0,6$	VR1	R	CR 400120
		10,5	3,4	5,5	3	$d_1 + 1$	$d_1 + 9$	$4,5 \pm 0,6$	VR1	V	CR 400124
		10,5	5,6	7,7	3	$d_1 + 1$	$d_1 + 9$	$6,7 \pm 0,6$	VR2	R	CR 400121
		10,5	5,6	7,7	3	$d_1 + 1$	$d_1 + 9$	$6,7 \pm 0,6$	VR2	V	CR 400125
12,5	13,5	11,7	3,4	5,5	3	$d_1 + 1$	$d_1 + 9$	$4,5 \pm 0,6$	VR1	R	CR 400130
		11,7	3,4	5,5	3	$d_1 + 1$	$d_1 + 9$	$4,5 \pm 0,6$	VR1	V	CR 400134

Select the larger V-ring when the dimension d_1 is on the boundary between two sizes of V-ring.

Dimensions		Seal inside diameter, free state d	Seal seat width b ₁	Nominal seal width b	Nominal seal height c	Clearance D ₁ max	Counterface D min	Seal fitted width B ₁	Design	Lip code	Designation
Shaft diameter range d ₁ over	incl.										
mm											
13,5	15,5	12,5	3,4	5,5	3	d ₁ +1	d ₁ +9	4,5±0,6	VR1	R	CR 400140
		12,5	3,4	5,5	3	d ₁ +1	d ₁ +9	4,5±0,6	VR1	V	CR 400144
		12,5	5,6	7,7	3	d ₁ +1	d ₁ +9	6,7±0,6	VR2	R	CR 400141
		12,5	5,6	7,7	3	d ₁ +1	d ₁ +9	6,7±0,6	VR2	V	CR 400145
15,5	17	14	3,4	5,5	3	d ₁ +1	d ₁ +9	4,5±0,6	VR1	R	CR 400160
		14	3,4	5,5	3	d ₁ +1	d ₁ +9	4,5±0,6	VR1	V	CR 400164
15,5	17,5	14	5,6	7,7	3	d ₁ +1	d ₁ +9	6,7±0,6	VR2	R	CR 400161
		14	5,6	7,7	3	d ₁ +1	d ₁ +9	6,7±0,6	VR2	V	CR 400165
17,5	19	16	3,4	5,5	3	d ₁ +1	d ₁ +9	4,5±0,6	VR1	R	CR 400180
		16	3,4	5,5	3	d ₁ +1	d ₁ +9	4,5±0,6	VR1	V	CR 400184
		16	5,6	7,7	3	d ₁ +1	d ₁ +9	6,7±0,6	VR2	R	CR 400181
		16	5,6	7,7	3	d ₁ +1	d ₁ +9	6,7±0,6	VR2	V	CR 400185
19	21	18	4,7	7,5	4	d ₁ +2	d ₁ +12	6,0±0,8	VR1	R	CR 400200
		18	4,7	7,5	4	d ₁ +2	d ₁ +12	6,0±0,8	VR1	V	CR 400204
		18	7,9	10,5	4	d ₁ +2	d ₁ +12	9,0±0,8	VR2	R	CR 400201
		18	7,9	10,5	4	d ₁ +2	d ₁ +12	9,0±0,8	VR2	V	CR 400205
21	24	20	4,7	7,5	4	d ₁ +2	d ₁ +12	6,0±0,8	VR1	R	CR 400220
		20	4,7	7,5	4	d ₁ +2	d ₁ +12	6,0±0,8	VR1	V	CR 400224
		20	7,9	10,5	4	d ₁ +2	d ₁ +12	9,0±0,8	VR2	R	CR 400221
		20	7,9	10,5	4	d ₁ +2	d ₁ +12	9,0±0,8	VR2	V	CR 400225
24	27	22	4,7	7,5	4	d ₁ +2	d ₁ +12	6,0±0,8	VR1	R	CR 400250
		22	4,7	7,5	4	d ₁ +2	d ₁ +12	6,0±0,8	VR1	V	CR 400254
		22	7,9	10,5	4	d ₁ +2	d ₁ +12	9,0±0,8	VR2	R	CR 400251
		22	7,9	10,5	4	d ₁ +2	d ₁ +12	9,0±0,8	VR2	V	CR 400255
27	29	25	4,7	7,5	4	d ₁ +2	d ₁ +12	6,0±0,8	VR1	R	CR 400280
		25	4,7	7,5	4	d ₁ +2	d ₁ +12	6,0±0,8	VR1	V	CR 400284
		25	7,9	10,5	4	d ₁ +2	d ₁ +12	9,0±0,8	VR2	R	CR 400281
		25	7,9	10,5	4	d ₁ +2	d ₁ +12	9,0±0,8	VR2	V	CR 400285
29	31	27	4,7	7,5	4	d ₁ +2	d ₁ +12	6,0±0,8	VR1	R	CR 400300
		27	4,7	7,5	4	d ₁ +2	d ₁ +12	6,0±0,8	VR1	V	CR 400304
		27	7,9	10,5	4	d ₁ +2	d ₁ +12	9,0±0,8	VR2	R	CR 400301
		27	7,9	10,5	4	d ₁ +2	d ₁ +12	9,0±0,8	VR2	V	CR 400305
31	33	29	4,7	7,5	4	d ₁ +2	d ₁ +12	6,0±0,8	VR1	R	CR 400320
		29	4,7	7,5	4	d ₁ +2	d ₁ +12	6,0±0,8	VR1	V	CR 400324
		29	7,9	10,5	4	d ₁ +2	d ₁ +12	9,0±0,8	VR2	R	CR 400321
		29	7,9	10,5	4	d ₁ +2	d ₁ +12	9,0±0,8	VR2	V	CR 400325
33	36	31	4,7	7,5	4	d ₁ +2	d ₁ +12	6,0±0,8	VR1	R	CR 400350
		31	4,7	7,5	4	d ₁ +2	d ₁ +12	6,0±0,8	VR1	V	CR 400354
		31	7,9	10,5	4	d ₁ +2	d ₁ +12	9,0±0,8	VR2	R	CR 400351
		31	7,9	10,5	4	d ₁ +2	d ₁ +12	9,0±0,8	VR2	V	CR 400355
36	38	34	4,7	7,5	4	d ₁ +2	d ₁ +12	6,0±0,8	VR1	R	CR 400380
		34	4,7	7,5	4	d ₁ +2	d ₁ +12	6,0±0,8	VR1	V	CR 400384
		34	7,9	10,5	4	d ₁ +2	d ₁ +12	9,0±0,8	VR2	R	CR 400381
		34	7,9	10,5	4	d ₁ +2	d ₁ +12	9,0±0,8	VR2	V	CR 400385
38	43	36	5,5	9	5	d ₁ +2	d ₁ +15	7,0±1	VR1	R	CR 400400
		36	5,5	9	5	d ₁ +2	d ₁ +15	7,0±1	VR1	V	CR 400404
		36	9,5	13	5	d ₁ +2	d ₁ +15	11,0±1	VR2	R	CR 400401
		36	9,5	13	5	d ₁ +2	d ₁ +15	11,0±1	VR2	V	CR 400405
43	48	40	5,5	9	5	d ₁ +2	d ₁ +15	7,0±1	VR1	R	CR 400450
		40	5,5	9	5	d ₁ +2	d ₁ +15	7,0±1	VR1	V	CR 400454
		40	9,5	13	5	d ₁ +2	d ₁ +15	11,0±1	VR2	R	CR 400451
		40	9,5	13	5	d ₁ +2	d ₁ +15	11,0±1	VR2	V	CR 400455

V-ring seals – metric dimensions, for North American market

d_1 48 – 175 mm

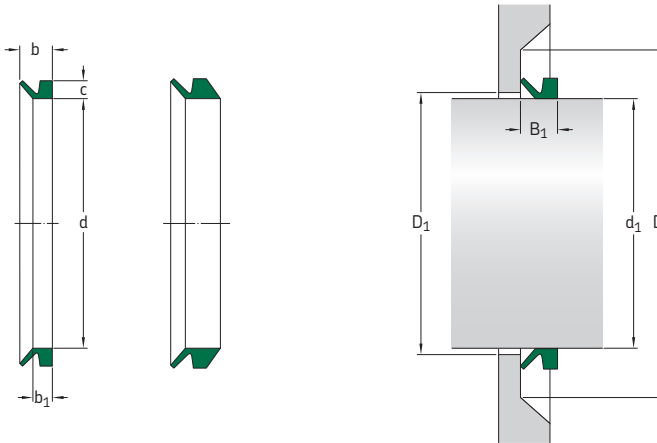

Dimensions		Seal inside diameter, free state d	Seal seat width b_1	Nominal seal width b	Nominal seal height c	Clearance D_1 max	Counterface D min	Seal fitted width B_1	Design	Lip code	Designation code
Shaft diameter range d_1 over	incl.										
mm											
48	53	45	5,5	9	5	$d_1 + 2$	$d_1 + 15$	$7,0 \pm 1$	VR1	R	CR 400500
		45	5,5	9	5	$d_1 + 2$	$d_1 + 15$	$7,0 \pm 1$	VR1	V	CR 400504
		45	9,5	13	5	$d_1 + 2$	$d_1 + 15$	$11,0 \pm 1$	VR2	R	CR 400501
		45	9,5	13	5	$d_1 + 2$	$d_1 + 15$	$11,0 \pm 1$	VR2	V	CR 400505
53	58	49	5,5	9	5	$d_1 + 2$	$d_1 + 15$	$7,0 \pm 1$	VR1	R	CR 400550
		49	5,5	9	5	$d_1 + 2$	$d_1 + 15$	$7,0 \pm 1$	VR1	V	CR 400554
		49	9,5	13	5	$d_1 + 2$	$d_1 + 15$	$11,0 \pm 1$	VR2	R	CR 400551
		49	9,5	13	5	$d_1 + 2$	$d_1 + 15$	$11,0 \pm 1$	VR2	V	CR 400555
58	63	54	5,5	9	5	$d_1 + 2$	$d_1 + 15$	$7,0 \pm 1$	VR1	R	CR 400600
		54	5,5	9	5	$d_1 + 2$	$d_1 + 15$	$7,0 \pm 1$	VR1	V	CR 400604
		54	9,5	13	5	$d_1 + 2$	$d_1 + 15$	$11,0 \pm 1$	VR2	R	CR 400601
		54	9,5	13	5	$d_1 + 2$	$d_1 + 15$	$11,0 \pm 1$	VR2	V	CR 400605
63	68	58	5,5	9	5	$d_1 + 2$	$d_1 + 15$	$7,0 \pm 1$	VR1	R	CR 400650
		58	5,5	9	5	$d_1 + 2$	$d_1 + 15$	$7,0 \pm 1$	VR1	V	CR 400654
		58	9,5	13	5	$d_1 + 2$	$d_1 + 15$	$11,0 \pm 1$	VR2	R	CR 400651
		58	9,5	13	5	$d_1 + 2$	$d_1 + 15$	$11,0 \pm 1$	VR2	V	CR 400655
68	73	63	6,8	11	6	$d_1 + 3$	$d_1 + 18$	$9,0 \pm 1,2$	VR1	R	CR 400700
		63	6,8	11	6	$d_1 + 3$	$d_1 + 18$	$9,0 \pm 1,2$	VR1	V	CR 400704
		63	11,3	15,5	6	$d_1 + 3$	$d_1 + 18$	$13,5 \pm 1,2$	VR2	R	CR 400701
		63	11,3	15,5	6	$d_1 + 3$	$d_1 + 18$	$13,5 \pm 1,2$	VR2	V	CR 400705
73	78	67	6,8	11	6	$d_1 + 3$	$d_1 + 18$	$9,0 \pm 1,2$	VR1	R	CR 400750
		67	6,8	11	6	$d_1 + 3$	$d_1 + 18$	$13,5 \pm 1,2$	VR2	R	CR 400751
		67	11,3	15,5	6	$d_1 + 3$	$d_1 + 18$	$13,5 \pm 1,2$	VR2	V	CR 400755
78	83	72	6,8	11	6	$d_1 + 3$	$d_1 + 18$	$9,0 \pm 1,2$	VR1	R	CR 400800
		72	6,8	11	6	$d_1 + 3$	$d_1 + 18$	$9,0 \pm 1,2$	VR1	V	CR 400804
		72	11,3	15,5	6	$d_1 + 3$	$d_1 + 18$	$13,5 \pm 1,2$	VR2	R	CR 400801
		72	11,3	15,5	6	$d_1 + 3$	$d_1 + 18$	$13,5 \pm 1,2$	VR2	V	CR 400805
83	88	76	6,8	11	6	$d_1 + 3$	$d_1 + 18$	$9,0 \pm 1,2$	VR1	R	CR 400850
		76	6,8	11	6	$d_1 + 3$	$d_1 + 18$	$9,0 \pm 1,2$	VR1	V	CR 400854
		76	11,3	15,5	6	$d_1 + 3$	$d_1 + 18$	$13,5 \pm 1,2$	VR2	R	CR 400851
		76	11,3	15,5	6	$d_1 + 3$	$d_1 + 18$	$13,5 \pm 1,2$	VR2	V	CR 400855

Select the larger V-ring when the dimension d_1 is on the boundary between two sizes of V-ring.

Dimensions		Seal inside diameter, free state d	Seal seat width b ₁	Nominal seal width b	Nominal seal height c	Clearance D ₁ max	Counterface D min	Seal fitted width B ₁	Design	Lip code	Designation
Shaft diameter range d ₁ over	incl.										
mm											
88	93	81	6,8	11	6	d ₁ +3	d ₁ +18	9,0±1,2	VR1	R	CR 400900
		81	6,8	11	6	d ₁ +3	d ₁ +18	9,0±1,2	VR1	V	CR 400904
		81	11,3	15,5	6	d ₁ +3	d ₁ +18	13,5±1,2	VR2	R	CR 400901
		81	11,3	15,5	6	d ₁ +3	d ₁ +18	13,5±1,2	VR2	V	CR 400905
93	98	85	6,8	11	6	d ₁ +3	d ₁ +18	9,0±1,2	VR1	R	CR 400950
		85	6,8	11	6	d ₁ +3	d ₁ +18	9,0±1,2	VR1	V	CR 400954
		85	11,3	15,5	6	d ₁ +3	d ₁ +18	13,5±1,2	VR2	R	CR 400951
		85	11,3	15,5	6	d ₁ +3	d ₁ +18	13,5±1,2	VR2	V	CR 400955
98	105	90	6,8	11	6	d ₁ +3	d ₁ +18	9,0±1,2	VR1	R	CR 401000
		90	6,8	11	6	d ₁ +3	d ₁ +18	9,0±1,2	VR1	V	CR 401004
		90	11,3	15,5	6	d ₁ +3	d ₁ +18	13,5±1,2	VR2	R	CR 401001
		90	11,3	15,5	6	d ₁ +3	d ₁ +18	13,5±1,2	VR2	V	CR 401005
105	115	99	6	10,5	6,5	d ₁ +5	d ₁ +20	8,0±1,5	VR3	R	CR 401102
		99	6	10,5	6,5	d ₁ +5	d ₁ +20	8,0±1,5	VR3	V	CR 401106
		99	7,9	12,8	7	d ₁ +4	d ₁ +21	10,5±1,5	VR1	R	CR 401100
		99	7,9	12,8	7	d ₁ +4	d ₁ +21	10,5±1,5	VR1	V	CR 401104
		99	13,1	18	7	d ₁ +4	d ₁ +21	15,5±1,5	VR2	R	CR 401101
		99	13,1	18	7	d ₁ +4	d ₁ +21	15,5±1,5	VR2	V	CR 401105
115	125	108	6	10,5	6,5	d ₁ +5	d ₁ +20	8,0±1,5	VR3	R	CR 401202
		108	6	10,5	6,5	d ₁ +5	d ₁ +20	8,0±1,5	VR3	V	CR 401206
		108	7,9	12,8	7	d ₁ +4	d ₁ +21	10,5±1,5	VR1	R	CR 401200
		108	7,9	12,8	7	d ₁ +4	d ₁ +21	10,5±1,5	VR1	V	CR 401204
		108	13,1	18	7	d ₁ +4	d ₁ +21	15,5±1,5	VR2	R	CR 401201
		108	13,1	18	7	d ₁ +4	d ₁ +21	15,5±1,5	VR2	V	CR 401205
125	135	117	6	10,5	6,5	d ₁ +5	d ₁ +20	8,0±1,5	VR3	R	CR 401302
		117	6	10,5	6,5	d ₁ +5	d ₁ +20	8,0±1,5	VR3	V	CR 401306
		117	7,9	12,8	7	d ₁ +4	d ₁ +21	10,5±1,5	VR1	R	CR 401300
		117	7,9	12,8	7	d ₁ +4	d ₁ +21	10,5±1,5	VR1	V	CR 401304
		117	13,1	18	7	d ₁ +4	d ₁ +21	15,5±1,5	VR2	R	CR 401301
		117	13,1	18	7	d ₁ +4	d ₁ +21	15,5±1,5	VR2	V	CR 401305
135	145	126	6	10,5	6,5	d ₁ +5	d ₁ +20	8,0±1,5	VR3	R	CR 401402
		126	6	10,5	6,5	d ₁ +5	d ₁ +20	8,0±1,5	VR3	V	CR 401406
		126	7,9	12,8	7	d ₁ +4	d ₁ +21	10,5±1,5	VR1	R	CR 401400
		126	7,9	12,8	7	d ₁ +4	d ₁ +21	10,5±1,5	VR1	V	CR 401404
		126	13,1	18	7	d ₁ +4	d ₁ +21	15,5±1,5	VR2	R	CR 401401
		126	13,1	18	7	d ₁ +4	d ₁ +21	15,5±1,5	VR2	V	CR 401405
145	155	135	6	10,5	6,5	d ₁ +5	d ₁ +20	8,0±1,5	VR3	R	CR 401502
		135	6	10,5	6,5	d ₁ +5	d ₁ +20	8,0±1,5	VR3	V	CR 401506
		135	7,9	12,8	7	d ₁ +4	d ₁ +21	10,5±1,5	VR1	R	CR 401500
		135	7,9	12,8	7	d ₁ +4	d ₁ +21	10,5±1,5	VR1	V	CR 401504
		135	13,1	18	7	d ₁ +4	d ₁ +21	15,5±1,5	VR2	R	CR 401501
		135	13,1	18	7	d ₁ +4	d ₁ +21	15,5±1,5	VR2	V	CR 401505
155	165	144	6	10,5	6,5	d ₁ +5	d ₁ +20	8,0±1,5	VR3	R	CR 401602
		144	6	10,5	6,5	d ₁ +5	d ₁ +20	8,0±1,5	VR3	V	CR 401606
		144	9	14,5	8	d ₁ +4	d ₁ +24	12,0±1,8	VR1	R	CR 401600
		144	9	14,5	8	d ₁ +4	d ₁ +24	12,0±1,8	VR1	V	CR 401604
		144	15	20,5	8	d ₁ +4	d ₁ +24	18,0±1,8	VR2	R	CR 401601
		144	15	20,5	8	d ₁ +4	d ₁ +24	18,0±1,8	VR2	V	CR 401605
165	175	153	6	10,5	6,5	d ₁ +5	d ₁ +20	8,0±1,5	VR3	R	CR 401702
		153	6	10,5	6,5	d ₁ +5	d ₁ +20	8,0±1,5	VR3	V	CR 401706
		153	9	14,5	8	d ₁ +4	d ₁ +24	12,0±1,8	VR1	R	CR 401700
		153	9	14,5	8	d ₁ +4	d ₁ +24	12,0±1,8	VR1	V	CR 401704
		153	15	20,5	8	d ₁ +4	d ₁ +24	18,0±1,8	VR2	R	CR 401701
		153	15	20,5	8	d ₁ +4	d ₁ +24	18,0±1,8	VR2	V	CR 401705

V-ring seals – metric dimensions, for North American market

d_1 175 – 375 mm

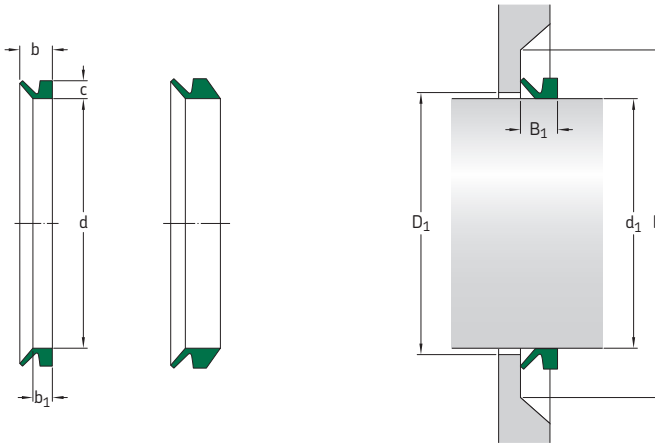

Dimensions		Seal inside diameter, free state d	Seal seat width b_1	Nominal seal width b	Nominal seal height c	Clearance D_1 max	Counterface D min	Seal fitted width B_1	Design	Lip code	Designation code
Shaft diameter range d_1 over	incl.										
mm											
175	185	162	6	10,5	6,5	$d_1 + 5$	$d_1 + 20$	$8,0 \pm 1,5$	VR3	R	CR 401802
		162	6	10,5	6,5	$d_1 + 5$	$d_1 + 20$	$8,0 \pm 1,5$	VR3	V	CR 401806
		162	9	14,5	8	$d_1 + 4$	$d_1 + 24$	$12,0 \pm 1,8$	VR1	R	CR 401800
		162	9	14,5	8	$d_1 + 4$	$d_1 + 24$	$12,0 \pm 1,8$	VR1	V	CR 401804
		162	15	20,5	8	$d_1 + 4$	$d_1 + 24$	$18,0 \pm 1,8$	VR2	R	CR 401801
		162	15	20,5	8	$d_1 + 4$	$d_1 + 24$	$18,0 \pm 1,8$	VR2	V	CR 401805
185	195	171	6	10,5	6,5	$d_1 + 5$	$d_1 + 20$	$8,0 \pm 1,5$	VR3	R	CR 401902
		171	6	10,5	6,5	$d_1 + 5$	$d_1 + 20$	$8,0 \pm 1,5$	VR3	V	CR 401906
		171	9	14,5	8	$d_1 + 4$	$d_1 + 24$	$12,0 \pm 1,8$	VR1	R	CR 401900
		171	9	14,5	8	$d_1 + 4$	$d_1 + 24$	$12,0 \pm 1,8$	VR1	V	CR 401904
		171	15	20,5	8	$d_1 + 4$	$d_1 + 24$	$18,0 \pm 1,8$	VR2	R	CR 401901
		171	15	20,5	8	$d_1 + 4$	$d_1 + 24$	$18,0 \pm 1,8$	VR2	V	CR 401905
195	210	180	9	14,5	8	$d_1 + 4$	$d_1 + 24$	$12,0 \pm 1,8$	VR1	R	CR 401990
		180	9	14,5	8	$d_1 + 4$	$d_1 + 24$	$12,0 \pm 1,8$	VR1	V	CR 401994
190	210	180	14,3	25	15	$d_1 + 10$	$d_1 + 45$	$20,0 \pm 4$	VR1	R	CR 402000
		180	14,3	25	15	$d_1 + 10$	$d_1 + 45$	$20,0 \pm 4$	VR1	V	CR 402004
195	210	180	15	20,5	8	$d_1 + 4$	$d_1 + 24$	$18,0 \pm 1,8$	VR2	R	CR 401991
		180	15	20,5	8	$d_1 + 4$	$d_1 + 24$	$18,0 \pm 1,8$	VR2	V	CR 401995
		182	6	10,5	6,5	$d_1 + 5$	$d_1 + 20$	$8,0 \pm 1,5$	VR3	R	CR 402002
		182	6	10,5	6,5	$d_1 + 5$	$d_1 + 20$	$8,0 \pm 1,5$	VR3	V	CR 402006
210	233	198	6	10,5	6,5	$d_1 + 5$	$d_1 + 20$	$8,0 \pm 1,5$	VR3	R	CR 402202
		198	6	10,5	6,5	$d_1 + 5$	$d_1 + 20$	$8,0 \pm 1,5$	VR3	V	CR 402206
210	235	198	14,3	25	15	$d_1 + 10$	$d_1 + 45$	$20,0 \pm 4$	VR1	R	CR 402200
		198	14,3	25	15	$d_1 + 10$	$d_1 + 45$	$20,0 \pm 4$	VR1	V	CR 402204
233	260	225	6	10,5	6,5	$d_1 + 5$	$d_1 + 20$	$8,0 \pm 1,5$	VR3	R	CR 402502
		225	6	10,5	6,5	$d_1 + 5$	$d_1 + 20$	$8,0 \pm 1,5$	VR3	V	CR 402506
235	265	225	14,3	25	15	$d_1 + 10$	$d_1 + 45$	$20,0 \pm 4$	VR1	R	CR 402500
		225	14,3	25	15	$d_1 + 10$	$d_1 + 45$	$20,0 \pm 4$	VR1	V	CR 402504
260	285	247	6	10,5	6,5	$d_1 + 5$	$d_1 + 20$	$8,0 \pm 1,5$	VR3	R	CR 402752
		247	6	10,5	6,5	$d_1 + 5$	$d_1 + 20$	$8,0 \pm 1,5$	VR3	V	CR 402756

Select the larger V-ring when the dimension d_1 is on the boundary between two sizes of V-ring.

Dimensions		Seal inside diameter, free state d	Seal seat width b ₁	Nominal seal width b	Nominal seal height c	Clearance D ₁ max	Counterface D min	Seal fitted width B ₁	Design	Lip code	Designation
Shaft diameter range d ₁ over	incl.										
mm											
265	290	247	14,3	25	15	d ₁ +10	d ₁ +45	20,0±4	VR1	R	CR 402750
		247	14,3	25	15	d ₁ +10	d ₁ +45	20,0±4	VR1	V	CR 402754
285	310	270	6	10,5	6,5	d ₁ +5	d ₁ +20	8,0±1,5	VR3	R	CR 403002
		270	6	10,5	6,5	d ₁ +5	d ₁ +20	8,0±1,5	VR3	V	CR 403006
290	310	270	14,3	25	15	d ₁ +10	d ₁ +45	20,0±4	VR1	R	CR 403000
		270	14,3	25	15	d ₁ +10	d ₁ +45	20,0±4	VR1	V	CR 403004
310	335	292	6	10,5	6,5	d ₁ +5	d ₁ +20	8,0±1,5	VR3	R	CR 403252
		292	6	10,5	6,5	d ₁ +5	d ₁ +20	8,0±1,5	VR3	V	CR 403256
		292	14,3	25	15	d ₁ +10	d ₁ +45	20,0±4	VR1	R	CR 403250
		292	14,3	25	15	d ₁ +10	d ₁ +45	20,0±4	VR1	V	CR 403254
300	305	294	32,5	65	21	d ₁ +24	d ₁ +115	50±12	VR6	R	CR 470301
		294	32,5	65	30	d ₁ +24	d ₁ +115	50±12	VR4	R	CR 403003
305	310	299	32,5	65	30	d ₁ +24	d ₁ +115	50±12	VR4	R	CR 403053
310	315	304	32,5	65	21	d ₁ +24	d ₁ +115	50±12	VR6	R	CR 470311
		304	32,5	65	30	d ₁ +24	d ₁ +115	50±12	VR4	R	CR 403103
315	320	309	32,5	65	30	d ₁ +24	d ₁ +115	50±12	VR4	R	CR 403153
320	325	314	32,5	65	30	d ₁ +24	d ₁ +115	50±12	VR4	R	CR 403203
335	365	315	6	10,5	6,5	d ₁ +5	d ₁ +20	8,0±1,5	VR3	R	CR 403502
		315	6	10,5	6,5	d ₁ +5	d ₁ +20	8,0±1,5	VR3	V	CR 403506
		315	14,3	25	15	d ₁ +10	d ₁ +45	20,0±4	VR1	R	CR 403500
		315	14,3	25	15	d ₁ +10	d ₁ +45	20,0±4	VR1	V	CR 403504
325	330	319	32,5	65	21	d ₁ +24	d ₁ +115	50±12	VR6	R	CR 470326
		319	32,5	65	30	d ₁ +24	d ₁ +115	50±12	VR4	R	CR 403253
330	335	323	32,5	65	30	d ₁ +24	d ₁ +115	50±12	VR4	R	CR 403303
335	340	328	32,5	65	30	d ₁ +24	d ₁ +115	50±12	VR4	R	CR 403353
340	345	333	32,5	65	21	d ₁ +24	d ₁ +115	50±12	VR6	R	CR 470341
		333	32,5	65	30	d ₁ +24	d ₁ +115	50±12	VR4	R	CR 403403
365	385	337	6	10,5	6,5	d ₁ +5	d ₁ +20	8,0±1,5	VR3	R	CR 403752
		337	6	10,5	6,5	d ₁ +5	d ₁ +20	8,0±1,5	VR3	V	CR 403756
365	390	337	14,3	25	15	d ₁ +10	d ₁ +45	20,0±4	VR1	R	CR 403750
		337	14,3	25	15	d ₁ +10	d ₁ +45	20,0±4	VR1	V	CR 403754
345	350	338	32,5	65	30	d ₁ +24	d ₁ +115	50±12	VR4	R	CR 403453
350	355	343	32,5	65	21	d ₁ +24	d ₁ +115	50±12	VR6	R	CR 470351
		343	32,5	65	30	d ₁ +24	d ₁ +115	50±12	VR4	R	CR 403503
355	360	347	32,5	65	21	d ₁ +24	d ₁ +115	50±12	VR6	R	CR 470356
		347	32,5	65	30	d ₁ +24	d ₁ +115	50±12	VR4	R	CR 403553
360	365	352	32,5	65	30	d ₁ +24	d ₁ +115	50±12	VR4	R	CR 403603
365	370	357	32,5	65	30	d ₁ +24	d ₁ +115	50±12	VR4	R	CR 403653
385	410	360	6	10,5	6,5	d ₁ +5	d ₁ +20	8,0±1,5	VR3	R	CR 404002
		360	6	10,5	6,5	d ₁ +5	d ₁ +20	8,0±1,5	VR3	V	CR 404006
390	430	360	14,3	25	15	d ₁ +10	d ₁ +45	20,0±4	VR1	R	CR 404000
		360	14,3	25	15	d ₁ +10	d ₁ +45	20,0±4	VR1	V	CR 404004
370	375	362	32,5	65	21	d ₁ +24	d ₁ +115	50±12	VR6	R	CR 470371
		362	32,5	65	30	d ₁ +24	d ₁ +115	50±12	VR4	R	CR 403703

7.1

V-ring seals – metric dimensions, for North American market

d_1 375 – 550 mm

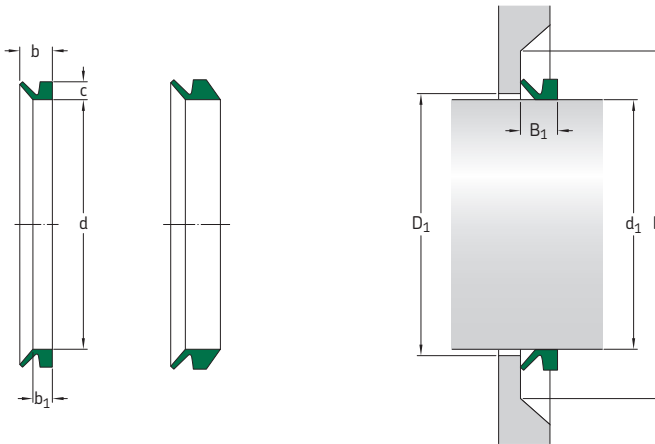

Dimensions		Seal inside diameter, free state d	Seal seat width b_1	Nominal seal width b	Nominal seal height c	Clearance D_1 max	Counterface D min	Seal fitted width B_1	Design	Lip code	Designation code
Shaft diameter range d_1 over	incl.										
mm											
375	380	367	32,5	65	21	$d_1 + 24$	$d_1 + 115$	50 ± 12	VR6	R	CR 470376
		367	32,5	65	30	$d_1 + 24$	$d_1 + 115$	50 ± 12	VR4	R	CR 403753
380	385	371	32,5	65	21	$d_1 + 24$	$d_1 + 115$	50 ± 12	VR6	R	CR 470381
		371	32,5	65	30	$d_1 + 24$	$d_1 + 115$	50 ± 12	VR4	R	CR 403803
385	390	376	32,5	65	30	$d_1 + 24$	$d_1 + 115$	50 ± 12	VR4	R	CR 403853
390	395	381	32,5	65	21	$d_1 + 24$	$d_1 + 115$	50 ± 12	VR6	R	CR 470391
		381	32,5	65	30	$d_1 + 24$	$d_1 + 115$	50 ± 12	VR4	R	CR 403903
410	440	382	6	10,5	6,5	$d_1 + 5$	$d_1 + 20$	$8,0 \pm 1,5$	VR3	R	CR 404252
		382	6	10,5	6,5	$d_1 + 5$	$d_1 + 20$	$8,0 \pm 1,5$	VR3	V	CR 404256
395	400	386	32,5	65	30	$d_1 + 24$	$d_1 + 115$	50 ± 12	VR4	R	CR 403953
400	405	391	32,5	65	21	$d_1 + 24$	$d_1 + 115$	50 ± 12	VR6	R	CR 470401
		391	32,5	65	30	$d_1 + 24$	$d_1 + 115$	50 ± 12	VR4	R	CR 404003
405	410	396	32,5	65	30	$d_1 + 24$	$d_1 + 115$	50 ± 12	VR4	R	CR 404053
410	415	401	32,5	65	21	$d_1 + 24$	$d_1 + 115$	50 ± 12	VR6	R	CR 470411
		401	32,5	65	30	$d_1 + 24$	$d_1 + 115$	50 ± 12	VR4	R	CR 404103
440	475	405	6	10,5	6,5	$d_1 + 5$	$d_1 + 20$	$8,0 \pm 1,5$	VR3	R	CR 404502
		405	6	10,5	6,5	$d_1 + 5$	$d_1 + 20$	$8,0 \pm 1,5$	VR3	V	CR 404506
430	480	405	14,3	25	15	$d_1 + 10$	$d_1 + 45$	$20,0 \pm 4$	VR1	R	CR 404500
		405	14,3	25	15	$d_1 + 10$	$d_1 + 45$	$20,0 \pm 4$	VR1	V	CR 404504
415	420	405	32,5	65	30	$d_1 + 24$	$d_1 + 115$	50 ± 12	VR4	R	CR 404153
420	425	410	32,5	65	21	$d_1 + 24$	$d_1 + 115$	50 ± 12	VR6	R	CR 470421
		410	32,5	65	30	$d_1 + 24$	$d_1 + 115$	50 ± 12	VR4	R	CR 404203
425	430	415	32,5	65	30	$d_1 + 24$	$d_1 + 115$	50 ± 12	VR4	R	CR 404253
430	435	420	32,5	65	21	$d_1 + 24$	$d_1 + 115$	50 ± 12	VR6	R	CR 470431
		420	32,5	65	30	$d_1 + 24$	$d_1 + 115$	50 ± 12	VR4	R	CR 404303

Select the larger V-ring when the dimension d_1 is on the boundary between two sizes of V-ring.

Dimensions		Seal inside diameter, free state d	Seal seat width b ₁	Nominal seal width b	Nominal seal height c	Clearance D ₁ max	Counterface D min	Seal fitted width B ₁	Design	Lip code	Designation
Shaft diameter range d ₁ over	incl.										
mm											
435	440	425	32,5	65	30	d ₁ +24	d ₁ +115	50±12	VR4	R	CR 404353
440	445	429	32,5	65	30	d ₁ +24	d ₁ +115	50±12	VR4	R	CR 404403
445	450	434	32,5	65	30	d ₁ +24	d ₁ +115	50±12	VR4	R	CR 404453
450	455	439 439	32,5 67,5	65 100	30 13	d ₁ +24 d ₁ +24	d ₁ +115 d ₁ +115	50±12 85±12	VR4 VR5	R R	CR 404503 CR 470450
455	460	444	32,5	65	30	d ₁ +24	d ₁ +115	50±12	VR4	R	CR 404553
460	465	448 448	32,5 32,5	65 65	21 30	d ₁ +24 d ₁ +24	d ₁ +115 d ₁ +115	50±12 50±12	VR6 VR4	R R	CR 470461 CR 404603
475	510	450 450	6 6	10,5 10,5	6,5 6,5	d ₁ +5 d ₁ +5	d ₁ +20 d ₁ +20	8,0±1,5 8,0±1,5	VR3 VR3	R V	CR 405002 CR 405006
480	530	450 450	14,3 14,3	25 25	15 15	d ₁ +10 d ₁ +10	d ₁ +45 d ₁ +45	20,0±4 20,0±4	VR1 VR1	R V	CR 405000 CR 405004
465	470	453	32,5	65	30	d ₁ +24	d ₁ +115	50±12	VR4	R	CR 404653
470	475	458	32,5	65	30	d ₁ +24	d ₁ +115	50±12	VR4	R	CR 404703
475	480	463 463	32,5 32,5	65 65	21 30	d ₁ +24 d ₁ +24	d ₁ +115 d ₁ +115	50±12 50±12	VR6 VR4	R R	CR 470476 CR 404753
480	485	468	32,5	65	30	d ₁ +24	d ₁ +115	50±12	VR4	R	CR 404803
510	540	472 472	6 6	10,5 10,5	6,5 6,5	d ₁ +5 d ₁ +5	d ₁ +20 d ₁ +20	8,0±1,5 8,0±1,5	VR3 VR3	R V	CR 405252 CR 405256
485	490	473	32,5	65	30	d ₁ +24	d ₁ +115	50±12	VR4	R	CR 404853
490	495	478	32,5	65	30	d ₁ +24	d ₁ +115	50±12	VR4	R	CR 404903
495	500	483 483	32,5 32,5	65 65	21 30	d ₁ +24 d ₁ +24	d ₁ +115 d ₁ +115	50±12 50±12	VR6 VR4	R R	CR 470496 CR 404953
500	505	488 488	32,5 67,5	65 100	30 13	d ₁ +24 d ₁ +24	d ₁ +115 d ₁ +115	50±12 85±12	VR4 VR5	R R	CR 405003 CR 470500
505	510	493	32,5	65	30	d ₁ +24	d ₁ +115	50±12	VR4	R	CR 405053
540	575	495 495	6 6	10,5 10,5	6,5 6,5	d ₁ +5 d ₁ +5	d ₁ +20 d ₁ +20	8,0±1,5 8,0±1,5	VR3 VR3	R V	CR 405502 CR 405506
530	580	495 495	14,3 14,3	25 25	15 15	d ₁ +10 d ₁ +10	d ₁ +45 d ₁ +45	20,0±4 20,0±4	VR1 VR1	R V	CR 405500 CR 405504
510	515	497	32,5	65	30	d ₁ +24	d ₁ +115	50±12	VR4	R	CR 405103
515	520	502	32,5	65	30	d ₁ +24	d ₁ +115	50±12	VR4	R	CR 405153
520	525	507	32,5	65	30	d ₁ +24	d ₁ +115	50±12	VR4	R	CR 405203
525	530	512 512	32,5 32,5	65 65	21 30	d ₁ +24 d ₁ +24	d ₁ +115 d ₁ +115	50±12 50±12	VR6 VR4	R R	CR 470526 CR 405253
530	535	517	32,5	65	30	d ₁ +24	d ₁ +115	50±12	VR4	R	CR 405303
535	540	521	32,5	65	30	d ₁ +24	d ₁ +115	50±12	VR4	R	CR 405353
540	545	526	32,5	65	30	d ₁ +24	d ₁ +115	50±12	VR4	R	CR 405403
545	550	531	32,5	65	30	d ₁ +24	d ₁ +115	50±12	VR4	R	CR 405453

7.1

V-ring seals – metric dimensions, for North American market

d_1 550 – 792 mm

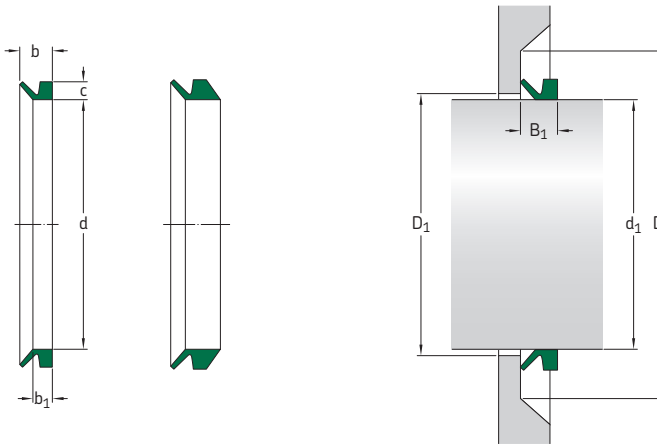

Dimensions		Seal inside diameter, free state d	Seal seat width b_1	Nominal seal width b	Nominal seal height c	Clearance D_1 max	Counterface D min	Seal fitted width B_1	Design	Lip code	Designation code
Shaft diameter range d_1 over	incl.										
mm											
550	555	536 536	32,5 67,5	65 100	30 13	$d_1 + 24$ $d_1 + 24$	$d_1 + 115$ $d_1 + 115$	50 ± 12 85 ± 12	VR4 VR5	R	CR 405503 CR 470550
575	625	540 540	6 6	10,5 10,5	6,5 6,5	$d_1 + 5$ $d_1 + 5$	$d_1 + 20$ $d_1 + 20$	$8,0 \pm 1,5$ $8,0 \pm 1,5$	VR3 VR3	R V	CR 406002 CR 406006
580	630	540 540	14,3 14,3	25 25	15 15	$d_1 + 10$ $d_1 + 10$	$d_1 + 45$ $d_1 + 45$	$20,0 \pm 4$ $20,0 \pm 4$	VR1 VR1	R V	CR 406000 CR 406004
555	560	541	32,5	65	30	$d_1 + 24$	$d_1 + 115$	50 ± 12	VR4	R	CR 405553
560	565	546	32,5	65	30	$d_1 + 24$	$d_1 + 115$	50 ± 12	VR4	R	CR 405603
565	570	550	32,5	65	30	$d_1 + 24$	$d_1 + 115$	50 ± 12	VR4	R	CR 405653
570	575	555	32,5	65	30	$d_1 + 24$	$d_1 + 115$	50 ± 12	VR4	R	CR 405703
575	580	560	32,5	65	30	$d_1 + 24$	$d_1 + 115$	50 ± 12	VR4	R	CR 405753
580	585	565	32,5	65	30	$d_1 + 24$	$d_1 + 115$	50 ± 12	VR4	R	CR 405803
585	590	570	32,5	65	30	$d_1 + 24$	$d_1 + 115$	50 ± 12	VR4	R	CR 405853
590	600	575	32,5	65	30	$d_1 + 24$	$d_1 + 115$	50 ± 12	VR4	R	CR 405903
600	610	582 582	32,5 67,5	65 100	30 13	$d_1 + 24$ $d_1 + 24$	$d_1 + 115$ $d_1 + 115$	50 ± 12 85 ± 12	VR4 VR5	R R	CR 406003 CR 470600
610	620	592	32,5	65	30	$d_1 + 24$	$d_1 + 115$	50 ± 12	VR4	R	CR 406103
615	675	600 600	6 6	10,5 10,5	6,5 6,5	$d_1 + 5$ $d_1 + 5$	$d_1 + 20$ $d_1 + 20$	$8,0 \pm 1,5$ $8,0 \pm 1,5$	VR3 VR3	R V	CR 406502 CR 406506
630	665	600 600	14,3 14,3	25 25	15 15	$d_1 + 10$ $d_1 + 10$	$d_1 + 45$ $d_1 + 45$	$20,0 \pm 4$ $20,0 \pm 4$	VR1 VR1	R V	CR 406500 CR 406504
620	630	602	32,5	65	30	$d_1 + 24$	$d_1 + 115$	50 ± 12	VR4	R	CR 406203
630	640	612	32,5	65	30	$d_1 + 24$	$d_1 + 115$	50 ± 12	VR4	R	CR 406303

Select the larger V-ring when the dimension d_1 is on the boundary between two sizes of V-ring.

Dimensions		Seal inside diameter, free state d	Seal seat width b ₁	Nominal seal width b	Nominal seal height c	Clearance D ₁ max	Counterface D min	Seal fitted width B ₁	Design	Lip code	Designation
Shaft diameter range d ₁ over	incl.										
mm											
640	650	621	32,5	65	30	d ₁ +24	d ₁ +115	50±12	VR4	R	CR 406403
675	710	630 630	6 6	10,5 10,5	6,5 6,5	d ₁ +5 d ₁ +5	d ₁ +20 d ₁ +20	8,0±1,5 8,0±1,5	VR3 VR3	R V	CR 407002 CR 407006
665	705	630 630	14,3 14,3	25 25	15 15	d ₁ +10 d ₁ +10	d ₁ +45 d ₁ +45	20,0±4 20,0±4	VR1 VR1	R V	CR 407000 CR 407004
650	660	631 631 631	32,5 32,5 67,5	65 65 100	21 30 13	d ₁ +24 d ₁ +24 d ₁ +24	d ₁ +115 d ₁ +115 d ₁ +115	50±12 50±12 85±12	VR6 VR4 VR5	R R R	CR 470651 CR 406503 CR 470650
660	670	640 640	32,5 32,5	65 65	21 30	d ₁ +24 d ₁ +24	d ₁ +115 d ₁ +115	50±12 50±12	VR6 VR4	R R	CR 470661 CR 406603
670	680	650 650	32,5 32,5	65 65	21 30	d ₁ +24 d ₁ +24	d ₁ +115 d ₁ +115	50±12 50±12	VR6 VR4	R R	CR 470671 CR 406703
680	690	660 660	32,5 32,5	65 65	21 30	d ₁ +24 d ₁ +24	d ₁ +115 d ₁ +115	50±12 50±12	VR6 VR4	R R	CR 470681 CR 406803
710	740	670 670	6 6	10,5 10,5	6,5 6,5	d ₁ +5 d ₁ +5	d ₁ +20 d ₁ +20	8,0±1,5 8,0±1,5	VR3 VR3	R V	CR 407252 CR 407256
705	745	670 670	14,3 14,3	25 25	15 15	d ₁ +10 d ₁ +10	d ₁ +45 d ₁ +45	20,0±4 20,0±4	VR1 VR1	R V	CR 407250 CR 407254
690	700	670 670	32,5 32,5	65 65	21 30	d ₁ +24 d ₁ +24	d ₁ +115 d ₁ +115	50±12 50±12	VR6 VR4	R R	CR 470691 CR 406903
700	710	680 680	32,5 67,5	65 100	30 13	d ₁ +24 d ₁ +24	d ₁ +115 d ₁ +115	50±12 85±12	VR4 VR5	R R	CR 407003 CR 470700
710	720	689	32,5	65	30	d ₁ +24	d ₁ +115	50±12	VR4	R	CR 407103
720	730	699	32,5	65	30	d ₁ +24	d ₁ +115	50±12	VR4	R	CR 407203
740	775	705 705	6 6	10,5 10,5	6,5 6,5	d ₁ +5 d ₁ +5	d ₁ +20 d ₁ +20	8,0±1,5 8,0±1,5	VR3 VR3	R V	CR 407502 CR 407506
745	785	705 705	14,3 14,3	25 25	15 15	d ₁ +10 d ₁ +10	d ₁ +45 d ₁ +45	20,0±4 20,0±4	VR1 VR1	R V	CR 407500 CR 407504
730	740	709	32,5	65	30	d ₁ +24	d ₁ +115	50±12	VR4	R	CR 407303
740	750	718	32,5	65	30	d ₁ +24	d ₁ +115	50±12	VR4	R	CR 407403
750	758	728 728 728	32,5 32,5 67,5	65 65 100	21 30 13	d ₁ +24 d ₁ +24 d ₁ +24	d ₁ +115 d ₁ +115 d ₁ +115	50±12 50±12 85±12	VR6 VR4 VR5	R R R	CR 470751 CR 407503 CR 470750
758	766	735 735	32,5 32,5	65 65	21 30	d ₁ +24 d ₁ +24	d ₁ +115 d ₁ +115	50±12 50±12	VR6 VR4	R R	CR 470761 CR 407603
766	774	743	32,5	65	30	d ₁ +24	d ₁ +115	50±12	VR4	R	CR 407703
775	825	745 745	6 6	10,5 10,5	6,5 6,5	d ₁ +5 d ₁ +5	d ₁ +20 d ₁ +20	8,0±1,5 8,0±1,5	VR3 VR3	R V	CR 408002 CR 408006
785	830	745 745	14,3 14,3	25 25	15 15	d ₁ +10 d ₁ +10	d ₁ +45 d ₁ +45	20,0±4 20,0±4	VR1 VR1	R V	CR 408000 CR 408004
774	783	751	32,5	65	30	d ₁ +24	d ₁ +115	50±12	VR4	R	CR 407803
783	792	759 759	32,5 32,5	65 65	21 30	d ₁ +24 d ₁ +24	d ₁ +115 d ₁ +115	50±12 50±12	VR6 VR4	R R	CR 470791 CR 407903

V-ring seals – metric dimensions, for North American market
 d_1 792 – 1 165 mm

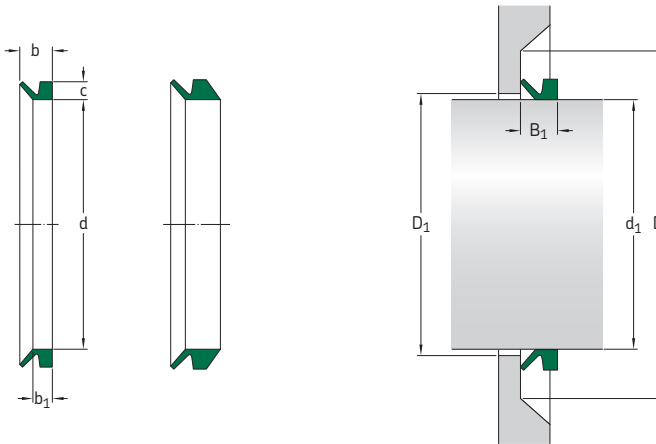

Dimensions			Seal inside diameter, free state d	Seal seat width b_1	Nominal seal width b	Nominal seal height c	Clearance D_1 max	Counterface D min	Seal fitted width B_1	Design	Lip code	Designation code
Shaft diameter range d_1 over	incl.											
mm												
792	801	768	32,5	65	21	$d_1 + 24$	$d_1 + 115$	50 ± 12	VR6	R	CR 470801	
		768	32,5	65	30	$d_1 + 24$	$d_1 + 115$	50 ± 12	VR4	R	CR 408003	
		768	67,5	100	13	$d_1 + 24$	$d_1 + 115$	85 ± 12	VR5	R	CR 470800	
801	810	777	32,5	65	30	$d_1 + 24$	$d_1 + 115$	50 ± 12	VR4	R	CR 408103	
825	875	785	6	10,5	6,5	$d_1 + 5$	$d_1 + 20$	$8,0 \pm 1,5$	VR3	R	CR 408502	
		785	6	10,5	6,5	$d_1 + 5$	$d_1 + 20$	$8,0 \pm 1,5$	VR3	V	CR 408506	
830	875	785	14,3	25	15	$d_1 + 10$	$d_1 + 45$	$20,0 \pm 4$	VR1	R	CR 408500	
		785	14,3	25	15	$d_1 + 10$	$d_1 + 45$	$20,0 \pm 4$	VR1	V	CR 408504	
810	821	786	32,5	65	30	$d_1 + 24$	$d_1 + 115$	50 ± 12	VR4	R	CR 408203	
821	831	796	32,5	65	21	$d_1 + 24$	$d_1 + 115$	50 ± 12	VR6	R	CR 470831	
		796	32,5	65	30	$d_1 + 24$	$d_1 + 115$	50 ± 12	VR4	R	CR 408303	
831	841	805	32,5	65	30	$d_1 + 24$	$d_1 + 115$	50 ± 12	VR4	R	CR 408403	
841	851	814	32,5	65	30	$d_1 + 24$	$d_1 + 115$	50 ± 12	VR4	R	CR 408503	
		814	67,5	100	13	$d_1 + 24$	$d_1 + 115$	85 ± 12	VR5	R	CR 470850	
851	861	824	32,5	65	30	$d_1 + 24$	$d_1 + 115$	50 ± 12	VR4	R	CR 408603	
875	925	825	6	10,5	6,5	$d_1 + 5$	$d_1 + 20$	$8,0 \pm 1,5$	VR3	R	CR 409002	
		825	6	10,5	6,5	$d_1 + 5$	$d_1 + 20$	$8,0 \pm 1,5$	VR3	V	CR 409006	
875	920	825	14,3	25	15	$d_1 + 10$	$d_1 + 45$	$20,0 \pm 4$	VR1	R	CR 409000	
		825	14,3	25	15	$d_1 + 10$	$d_1 + 45$	$20,0 \pm 4$	VR1	V	CR 409004	
861	871	833	32,5	65	30	$d_1 + 24$	$d_1 + 115$	50 ± 12	VR4	R	CR 408703	
871	882	843	32,5	65	21	$d_1 + 24$	$d_1 + 115$	50 ± 12	VR6	R	CR 470881	
		843	32,5	65	30	$d_1 + 24$	$d_1 + 115$	50 ± 12	VR4	R	CR 408803	
882	892	853	32,5	65	30	$d_1 + 24$	$d_1 + 115$	50 ± 12	VR4	R	CR 408903	
925	975	865	6	10,5	6,5	$d_1 + 5$	$d_1 + 20$	$8,0 \pm 1,5$	VR3	R	CR 409502	
		865	6	10,5	6,5	$d_1 + 5$	$d_1 + 20$	$8,0 \pm 1,5$	VR3	V	CR 409506	

Select the larger V-ring when the dimension d_1 is on the boundary between two sizes of V-ring.

Dimensions		Seal inside diameter, free state d	Seal seat width b ₁	Nominal seal width b	Nominal seal height c	Clearance D ₁ max	Counterface D min	Seal fitted width B ₁	Design	Lip code	Designation
Shaft diameter range d ₁ over	incl.										
mm											
920	965	865	14,3	25	15	d ₁ +10	d ₁ +45	20,0±4	VR1	R	CR 409500
		865	14,3	25	15	d ₁ +10	d ₁ +45	20,0±4	VR1	V	CR 409504
892	912	871	32,5	65	21	d ₁ +24	d ₁ +115	50±12	VR6	R	CR 470901
		871	32,5	65	30	d ₁ +24	d ₁ +115	50±12	VR4	R	CR 409003
		871	67,5	100	13	d ₁ +24	d ₁ +115	85±12	VR5	R	CR 470900
912	922	880	32,5	65	30	d ₁ +24	d ₁ +115	50±12	VR4	R	CR 409203
922	933	890	32,5	65	30	d ₁ +24	d ₁ +115	50±12	VR4	R	CR 409303
933	944	900	32,5	65	30	d ₁ +24	d ₁ +115	50±12	VR4	R	CR 409403
975	1025	910	6	10,5	6,5	d ₁ +5	d ₁ +20	8,0±1,5	VR3	R	CR 410002
		910	6	10,5	6,5	d ₁ +5	d ₁ +20	8,0±1,5	VR3	V	CR 410006
944	955	911	32,5	65	30	d ₁ +24	d ₁ +115	50±12	VR4	R	CR 409503
		911	67,5	100	13	d ₁ +24	d ₁ +115	85±12	VR5	R	CR 470950
955	966	921	32,5	65	30	d ₁ +24	d ₁ +115	50±12	VR4	R	CR 409603
966	977	932	32,5	65	30	d ₁ +24	d ₁ +115	50±12	VR4	R	CR 409703
977	988	942	32,5	65	21	d ₁ +24	d ₁ +115	50±12	VR6	R	CR 470981
		942	32,5	65	30	d ₁ +24	d ₁ +115	50±12	VR4	R	CR 409803
988	999	953	32,5	65	30	d ₁ +24	d ₁ +115	50±12	VR4	R	CR 409903
1025	1075	955	6	10,5	6,5	d ₁ +5	d ₁ +20	8,0±1,5	VR3	R	CR 410502
		955	6	10,5	6,5	d ₁ +5	d ₁ +20	8,0±1,5	VR3	V	CR 410506
1015	1065	955	14,3	25	15	d ₁ +10	d ₁ +45	20,0±4	VR1	R	CR 410500
999	1010	963	32,5	65	30	d ₁ +24	d ₁ +115	50±12	VR4	R	CR 410003
		963	67,5	100	13	d ₁ +24	d ₁ +115	85±12	VR5	R	CR 471000
1010	1025	973	32,5	65	30	d ₁ +24	d ₁ +115	50±12	VR4	R	CR 410203
1025	1045	990	32,5	65	21	d ₁ +24	d ₁ +115	50±12	VR6	R	CR 471041
		990	32,5	65	30	d ₁ +24	d ₁ +115	50±12	VR4	R	CR 410403
1075	1125	1000	6	10,5	6,5	d ₁ +5	d ₁ +20	8,0±1,5	VR3	R	CR 411002
		1000	6	10,5	6,5	d ₁ +5	d ₁ +20	8,0±1,5	VR3	V	CR 411006
1065	1115	1000	14,3	25	15	d ₁ +10	d ₁ +45	20,0±4	VR1	R	CR 411000
1045	1065	1008	32,5	65	30	d ₁ +24	d ₁ +115	50±12	VR4	R	CR 410603
1065	1085	1027	32,5	65	30	d ₁ +24	d ₁ +115	50±12	VR4	R	CR 410803
1125	1175	1045	6	10,5	6,5	d ₁ +5	d ₁ +20	8,0±1,5	VR3	R	CR 411502
		1045	6	10,5	6,5	d ₁ +5	d ₁ +20	8,0±1,5	VR3	V	CR 411506
1115	1165	1045	14,3	25	15	d ₁ +10	d ₁ +45	20,0±4	VR1	R	CR 411500
1085	1105	1045	32,5	65	30	d ₁ +24	d ₁ +115	50±12	VR4	R	CR 411003
		1045	67,5	100	13	d ₁ +24	d ₁ +115	85±12	VR5	R	CR 471100
1105	1125	1065	32,5	65	30	d ₁ +24	d ₁ +115	50±12	VR4	R	CR 411203
1125	1145	1084	32,5	65	30	d ₁ +24	d ₁ +115	50±12	VR4	R	CR 411403
1175	1225	1090	6	10,5	6,5	d ₁ +5	d ₁ +20	8,0±1,5	VR3	R	CR 412002
1165	1215	1090	14,3	25	15	d ₁ +10	d ₁ +45	20,0±4	VR1	R	CR 412000
1145	1165	1103	32,5	65	30	d ₁ +24	d ₁ +115	50±12	VR4	R	CR 411603

7.1

V-ring seals – metric dimensions, for North American market

d_1 1 165 – 1 775 mm

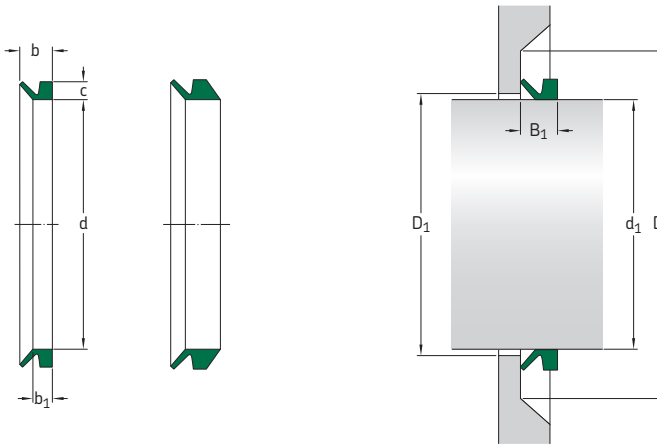

Dimensions		Seal inside diameter, free state d	Seal seat width b_1	Nominal seal width b	Nominal seal height c	Clearance D_1 max	Counterface D min	Seal fitted width B_1	Design	Lip code	Designation code
Shaft diameter range d_1 over	incl.										
mm											
1 165	1 185	1 121	32,5	65	30	$d_1 + 24$	$d_1 + 115$	50 ± 12	VR4	R	CR 411803
1 225	1 275	1 135	6	10,5	6,5	$d_1 + 5$	$d_1 + 20$	$8,0 \pm 1,5$	VR3	R	CR 412502
		1 135	6	10,5	6,5	$d_1 + 5$	$d_1 + 20$	$8,0 \pm 1,5$	VR3	V	CR 412506
1 215	1 270	1 135	14,3	25	15	$d_1 + 10$	$d_1 + 45$	$20,0 \pm 4$	VR1	R	CR 412500
1 185	1 205	1 139	32,5	65	21	$d_1 + 24$	$d_1 + 115$	50 ± 12	VR6	R	CR 471201
		1 139	32,5	65	30	$d_1 + 24$	$d_1 + 115$	50 ± 12	VR4	R	CR 412003
		1 139	67,5	100	13	$d_1 + 24$	$d_1 + 115$	85 ± 12	VR5	R	CR 471200
1 205	1 225	1 157	32,5	65	30	$d_1 + 24$	$d_1 + 115$	50 ± 12	VR4	R	CR 412203
1 225	1 245	1 176	32,5	65	30	$d_1 + 24$	$d_1 + 115$	50 ± 12	VR4	R	CR 412403
1 275	1 325	1 180	6	10,5	6,5	$d_1 + 5$	$d_1 + 20$	$8,0 \pm 1,5$	VR3	R	CR 413002
		1 180	6	10,5	6,5	$d_1 + 5$	$d_1 + 20$	$8,0 \pm 1,5$	VR3	V	CR 413006
1 270	1 320	1 180	14,3	25	15	$d_1 + 10$	$d_1 + 45$	$20,0 \pm 4$	VR1	R	CR 413000
1 245	1 270	1 195	32,5	65	30	$d_1 + 24$	$d_1 + 115$	50 ± 12	VR4	R	CR 412603
1 270	1 295	1 218	32,5	65	30	$d_1 + 24$	$d_1 + 115$	50 ± 12	VR4	R	CR 412803
1 325	1 375	1 225	6	10,5	6,5	$d_1 + 5$	$d_1 + 20$	$8,0 \pm 1,5$	VR3	R	CR 413502
		1 225	6	10,5	6,5	$d_1 + 5$	$d_1 + 20$	$8,0 \pm 1,5$	VR3	V	CR 413506
1 320	1 370	1 225	14,3	25	15	$d_1 + 10$	$d_1 + 45$	$20,0 \pm 4$	VR1	R	CR 413500
1 295	1 315	1 240	32,5	65	30	$d_1 + 24$	$d_1 + 115$	50 ± 12	VR4	R	CR 413003
		1 240	67,5	100	13	$d_1 + 24$	$d_1 + 115$	85 ± 12	VR5	R	CR 471300
1 315	1 340	1 259	32,5	65	30	$d_1 + 24$	$d_1 + 115$	50 ± 12	VR4	R	CR 413253
1 375	1 425	1 270	6	10,5	6,5	$d_1 + 5$	$d_1 + 20$	$8,0 \pm 1,5$	VR3	R	CR 414002
		1 270	6	10,5	6,5	$d_1 + 5$	$d_1 + 20$	$8,0 \pm 1,5$	VR3	V	CR 414006
1 370	1 420	1 270	14,3	25	15	$d_1 + 10$	$d_1 + 45$	$20,0 \pm 4$	VR1	R	CR 414000

Select the larger V-ring when the dimension d_1 is on the boundary between two sizes of V-ring.

Dimensions		Seal inside diameter, free state d	Seal seat width b ₁	Nominal seal width b	Nominal seal height c	Clearance D ₁ max	Counterface D min	Seal fitted width B ₁	Design	Lip code	Designation
Shaft diameter range d ₁ over	incl.										
mm											
1 340 1 365	1 281	32,5	65	30	d ₁ +24	d ₁ +115	50±12	VR4	R	CR 413503	
	1 281	67,5	100	13	d ₁ +24	d ₁ +115	85±12	VR5	R	CR 471350	
1 365 1 390	1 305	32,5	65	30	d ₁ +24	d ₁ +115	50±12	VR4	R	CR 413753	
1 425 1 475	1 315	6	10,5	6,5	d ₁ +5	d ₁ +20	8,0±1,5	VR3	R	CR 414502	
	1 315	6	10,5	6,5	d ₁ +5	d ₁ +20	8,0±1,5	VR3	V	CR 414506	
1 420 1 470	1 315	14,3	25	15	d ₁ +10	d ₁ +45	20,0±4	VR1	R	CR 414500	
1 390 1 415	1 328	32,5	65	30	d ₁ +24	d ₁ +115	50±12	VR4	R	CR 414003	
	1 328	67,5	100	13	d ₁ +24	d ₁ +115	85±12	VR5	R	CR 471400	
1 415 1 440	1 350	32,5	65	21	d ₁ +24	d ₁ +115	50±12	VR6	R	CR 471426	
	1 350	32,5	65	30	d ₁ +24	d ₁ +115	50±12	VR4	R	CR 414253	
1 475 1 525	1 360	6	10,5	6,5	d ₁ +5	d ₁ +20	8,0±1,5	VR3	R	CR 415002	
	1 360	6	10,5	6,5	d ₁ +5	d ₁ +20	8,0±1,5	VR3	V	CR 415006	
1 470 1 520	1 360	14,3	25	15	d ₁ +10	d ₁ +45	20,0±4	VR1	R	CR 415000	
1 440 1 465	1 374	32,5	65	21	d ₁ +24	d ₁ +115	50±12	VR6	R	CR 471451	
	1 374	32,5	65	30	d ₁ +24	d ₁ +115	50±12	VR4	R	CR 414503	
	1 374	67,5	100	13	d ₁ +24	d ₁ +115	85±12	VR5	R	CR 471450	
1 465 1 490	1 397	32,5	65	30	d ₁ +24	d ₁ +115	50±12	VR4	R	CR 414753	
1 525 1 575	1 405	6	10,5	6,5	d ₁ +5	d ₁ +20	8,0±1,5	VR3	R	CR 415502	
	1 405	6	10,5	6,5	d ₁ +5	d ₁ +20	8,0±1,5	VR3	V	CR 415506	
1 520 1 570	1 405	14,3	25	15	d ₁ +10	d ₁ +45	20,0±4	VR1	R	CR 415500	
1 490 1 515	1 419	32,5	65	21	d ₁ +24	d ₁ +115	50±12	VR6	R	CR 471501	
	1 419	32,5	65	30	d ₁ +24	d ₁ +115	50±12	VR4	R	CR 415003	
	1 419	67,5	100	13	d ₁ +24	d ₁ +115	85±12	VR5	R	CR 471500	
1 515 1 540	1 443	32,5	65	30	d ₁ +24	d ₁ +115	50±12	VR4	R	CR 415253	
1 575 1 625	1 450	6	10,5	6,5	d ₁ +5	d ₁ +20	8,0±1,5	VR3	R	CR 416002	
	1 450	6	10,5	6,5	d ₁ +5	d ₁ +20	8,0±1,5	VR3	V	CR 416006	
1 570 1 620	1 450	14,3	25	15	d ₁ +10	d ₁ +45	20,0±4	VR1	R	CR 416000	
1 540 1 570	1 467	32,5	65	21	d ₁ +24	d ₁ +115	50±12	VR6	R	CR 471551	
	1 467	32,5	65	30	d ₁ +24	d ₁ +115	50±12	VR4	R	CR 415503	
	1 467	67,5	100	13	d ₁ +24	d ₁ +115	85±12	VR5	R	CR 471550	
1 625 1 675	1 495	6	10,5	6,5	d ₁ +5	d ₁ +20	8,0±1,5	VR3	R	CR 416502	
	1 495	6	10,5	6,5	d ₁ +5	d ₁ +20	8,0±1,5	VR3	V	CR 416506	
1 620 1 670	1 495	14,3	25	15	d ₁ +10	d ₁ +45	20,0±4	VR1	R	CR 416500	
1 570 1 600	1 495	32,5	65	30	d ₁ +24	d ₁ +115	50±12	VR4	R	CR 415753	
1 600 1 640	1 524	32,5	65	30	d ₁ +24	d ₁ +115	50±12	VR4	R	CR 416003	
	1 524	67,5	100	13	d ₁ +24	d ₁ +115	85±12	VR5	R	CR 471600	
1 675 1 725	1 540	6	10,5	6,5	d ₁ +5	d ₁ +20	8,0±1,5	VR3	R	CR 417002	
	1 540	6	10,5	6,5	d ₁ +5	d ₁ +20	8,0±1,5	VR3	V	CR 417006	
1 670 1 720	1 540	14,3	25	15	d ₁ +10	d ₁ +45	20,0±4	VR1	R	CR 417000	
1 640 1 680	1 559	32,5	65	30	d ₁ +24	d ₁ +115	50±12	VR4	R	CR 416503	
	1 559	67,5	100	13	d ₁ +24	d ₁ +115	85±12	VR5	R	CR 471650	
1 725 1 775	1 585	6	10,5	6,5	d ₁ +5	d ₁ +20	8,0±1,5	VR3	R	CR 417502	
	1 585	6	10,5	6,5	d ₁ +5	d ₁ +20	8,0±1,5	VR3	V	CR 417506	

7.1

V-ring seals – metric dimensions, for North American market

d_1 1 720 – 2 010 mm

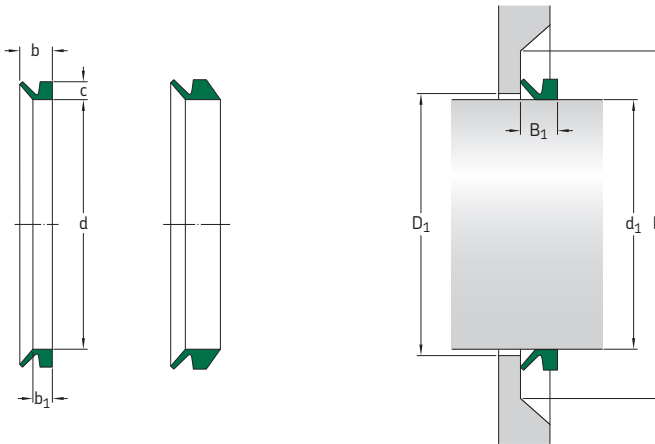

Dimensions		Seal inside diameter, free state d	Seal seat width b_1	Nominal seal width b	Nominal seal height c	Clearance D_1 max	Counterface D min	Seal fitted width B_1	Design	Lip code	Designation code
Shaft diameter range d_1 over	incl.										
mm											
1 720	1 770	1 585	14,3	25	15	$d_1 + 10$	$d_1 + 45$	$20,0 \pm 4$	VR1	R	CR 417500
1 680	1 720	1 596	32,5	65	21	$d_1 + 24$	$d_1 + 115$	50 ± 12	VR6	R	CR 471701
		1 596	32,5	65	30	$d_1 + 24$	$d_1 + 115$	50 ± 12	VR4	R	CR 417003
		1 596	67,5	100	13	$d_1 + 24$	$d_1 + 115$	85 ± 12	VR5	R	CR 471700
1 775	1 825	1 630	6	10,5	6,5	$d_1 + 5$	$d_1 + 20$	$8,0 \pm 1,5$	VR3	R	CR 418002
		1 630	6	10,5	6,5	$d_1 + 5$	$d_1 + 20$	$8,0 \pm 1,5$	VR3	V	CR 418006
1 770	1 820	1 630	14,3	25	15	$d_1 + 10$	$d_1 + 45$	$20,0 \pm 4$	VR1	R	CR 418000
1 720	1 765	1 632	32,5	65	21	$d_1 + 24$	$d_1 + 115$	50 ± 12	VR6	R	CR 471751
		1 632	32,5	65	30	$d_1 + 24$	$d_1 + 115$	50 ± 12	VR4	R	CR 417503
		1 632	67,5	100	13	$d_1 + 24$	$d_1 + 115$	85 ± 12	VR5	R	CR 471750
1 765	1 810	1 671	32,5	65	30	$d_1 + 24$	$d_1 + 115$	50 ± 12	VR4	R	CR 418003
		1 671	67,5	100	13	$d_1 + 24$	$d_1 + 115$	85 ± 12	VR5	R	CR 471800
1 825	1 875	1 675	6	10,5	6,5	$d_1 + 5$	$d_1 + 20$	$8,0 \pm 1,5$	VR3	R	CR 418502
		1 675	6	10,5	6,5	$d_1 + 5$	$d_1 + 20$	$8,0 \pm 1,5$	VR3	V	CR 418506
1 820	1 870	1 675	14,3	25	15	$d_1 + 10$	$d_1 + 45$	$20,0 \pm 4$	VR1	R	CR 418500
1 810	1 855	1 714	32,5	65	21	$d_1 + 24$	$d_1 + 115$	50 ± 12	VR6	R	CR 471851
		1 714	32,5	65	30	$d_1 + 24$	$d_1 + 115$	50 ± 12	VR4	R	CR 418503
		1 714	67,5	100	13	$d_1 + 24$	$d_1 + 115$	85 ± 12	VR5	R	CR 471850
1 875	1 925	1 720	6	10,5	6,5	$d_1 + 5$	$d_1 + 20$	$8,0 \pm 1,5$	VR3	R	CR 419002
		1 720	6	10,5	6,5	$d_1 + 5$	$d_1 + 20$	$8,0 \pm 1,5$	VR3	V	CR 419006
1 870	1 920	1 720	14,3	25	15	$d_1 + 10$	$d_1 + 45$	$20,0 \pm 4$	VR1	R	CR 419000
1 855	1 905	1 753	32,5	65	21	$d_1 + 24$	$d_1 + 115$	50 ± 12	VR6	R	CR 471901
		1 753	32,5	65	30	$d_1 + 24$	$d_1 + 115$	50 ± 12	VR4	R	CR 419003
		1 753	67,5	100	13	$d_1 + 24$	$d_1 + 115$	85 ± 12	VR5	R	CR 471900
1 925	1 975	1 765	6	10,5	6,5	$d_1 + 5$	$d_1 + 20$	$8,0 \pm 1,5$	VR3	R	CR 419502
		1 765	6	10,5	6,5	$d_1 + 5$	$d_1 + 20$	$8,0 \pm 1,5$	VR3	V	CR 419506
1 920	1 970	1 765	14,3	25	15	$d_1 + 10$	$d_1 + 45$	$20,0 \pm 4$	VR1	R	CR 419500

Select the larger V-ring when the dimension d_1 is on the boundary between two sizes of V-ring.

Dimensions		Seal inside diameter, free state d	Seal seat width b ₁	Nominal seal width b	Nominal seal height c	Clearance D ₁ max	Counterface D min	Seal fitted width B ₁	Design	Lip code	Designation
Shaft diameter range d ₁ over	incl.										
mm											
1 905	1 955	1 794	32,5	65	21	d ₁ + 24	d ₁ + 115	50 ± 12	VR6	R	CR 471951
		1 794	32,5	65	30	d ₁ + 24	d ₁ + 115	50 ± 12	VR4	R	CR 419503
		1 794	67,5	100	13	d ₁ + 24	d ₁ + 115	85 ± 12	VR5	R	CR 471950
1 975	2 025	1 810	6	10,5	6,5	d ₁ + 5	d ₁ + 20	8,0 ± 1,5	VR3	R	CR 420002
		1 810	6	10,5	6,5	d ₁ + 5	d ₁ + 20	8,0 ± 1,5	VR3	V	CR 420006
1 970	2 020	1 810	14,3	25	15	d ₁ + 10	d ₁ + 45	20,0 ± 4	VR1	R	CR 420000
1 955	2 010	1 844	32,5	65	30	d ₁ + 24	d ₁ + 115	50 ± 12	VR4	R	CR 420003
		1 844	67,5	100	13	d ₁ + 24	d ₁ + 115	85 ± 12	VR5	R	CR 472000

V-ring seals – inch dimensions, for North American market

d_1 0.110 – 1.890 in.

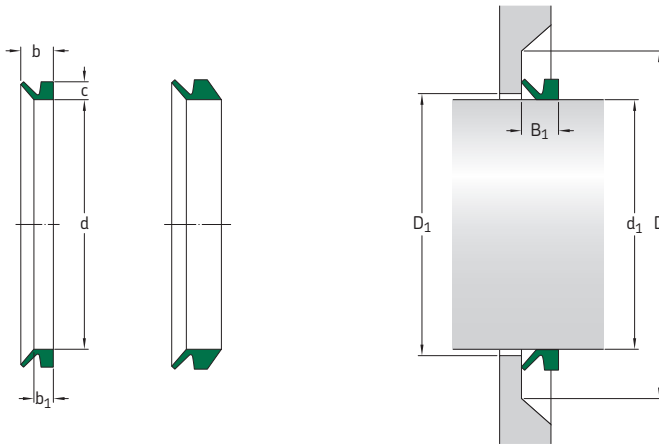

Dimensions		Ref. metric dim.	Seal inside diameter, free state d	Seal seat width b_1	Nominal seal width b	Nominal seal height c	Clearance D_1 max	Counter-face D min	Seal fitted width B_1	Design	Lip code	Designation
Shaft diameter range d_1 over	incl.											
in.	mm	in.								-	-	-
0.110	0.140	3	0.100	0.060	0.080	0.120	0.040	0.160	0.100 ± 0.012	VR1	R	CR 400030
		3	0.100	0.060	0.080	0.120	0.040	0.160	0.100 ± 0.012	VR1	V	CR 400034
0.140	0.180	4	0.130	0.080	0.090	0.150	0.040	0.240	0.120 ± 0.016	VR1	R	CR 400040
		4	0.130	0.080	0.090	0.150	0.040	0.240	0.120 ± 0.016	VR1	V	CR 400044
0.180	0.210	5	0.160	0.080	0.090	0.150	0.040	0.240	0.120 ± 0.016	VR1	R	CR 400050
		5	0.160	0.080	0.150	0.200	0.040	0.240	0.180 ± 0.016	VR2	R	CR 400051
		5	0.160	0.080	0.090	0.150	0.040	0.240	0.120 ± 0.016	VR1	V	CR 400054
		5	0.160	0.080	0.150	0.200	0.040	0.240	0.180 ± 0.016	VR2	V	CR 400055
0.210	0.260	6	0.200	0.080	0.090	0.150	0.040	0.240	0.120 ± 0.016	VR1	R	CR 400060
		6	0.200	0.080	0.150	0.200	0.040	0.240	0.180 ± 0.016	VR2	R	CR 400061
		6	0.200	0.080	0.090	0.150	0.040	0.240	0.120 ± 0.016	VR1	V	CR 400064
		6	0.200	0.080	0.150	0.200	0.040	0.240	0.180 ± 0.016	VR2	V	CR 400065
0.260	0.310	7	0.240	0.080	0.090	0.150	0.040	0.240	0.120 ± 0.016	VR1	R	CR 400070
		7	0.240	0.080	0.150	0.200	0.040	0.240	0.180 ± 0.016	VR2	R	CR 400071
		7	0.240	0.080	0.090	0.150	0.040	0.240	0.120 ± 0.016	VR1	V	CR 400074
		7	0.240	0.080	0.150	0.200	0.040	0.240	0.180 ± 0.016	VR2	V	CR 400075
0.310	0.370	8	0.280	0.080	0.090	0.150	0.040	0.240	0.120 ± 0.016	VR1	R	CR 400080
		8	0.280	0.080	0.150	0.200	0.040	0.240	0.180 ± 0.016	VR2	R	CR 400081
		8	0.280	0.080	0.090	0.150	0.040	0.240	0.120 ± 0.016	VR1	V	CR 400084
		8	0.280	0.080	0.150	0.200	0.040	0.240	0.180 ± 0.016	VR2	V	CR 400085
0.370	0.450	10	0.350	0.120	0.130	0.220	0.080	0.350	0.180 ± 0.020	VR1	R	CR 400100
		10	0.350	0.120	0.220	0.300	0.080	0.350	0.260 ± 0.020	VR2	R	CR 400101
		10	0.350	0.120	0.130	0.220	0.080	0.350	0.180 ± 0.020	VR1	V	CR 400104
		10	0.350	0.120	0.220	0.300	0.080	0.350	0.260 ± 0.020	VR2	V	CR 400105
0.450	0.530	12	0.410	0.120	0.130	0.220	0.080	0.350	0.180 ± 0.020	VR1	R	CR 400120
		12	0.410	0.120	0.220	0.300	0.080	0.350	0.260 ± 0.020	VR2	R	CR 400121
		12	0.410	0.120	0.130	0.220	0.080	0.350	0.180 ± 0.020	VR1	V	CR 400124
		12	0.410	0.120	0.220	0.300	0.080	0.350	0.260 ± 0.020	VR2	V	CR 400125
0.490	0.570	13	0.450	0.120	0.130	0.220	0.080	0.350	0.180 ± 0.020	VR1	R	CR 400130
		13	0.450	0.120	0.130	0.220	0.080	0.350	0.180 ± 0.020	VR1	V	CR 400134

Select the larger V-ring when the dimension d_1 is on the boundary between two sizes of V-ring.

Dimensions		Ref. metric dim.	Seal inside diameter, free state d	Seal seat width b ₁	Nominal seal width b	Nominal seal height c	Clearance D ₁ max	Counter-face D min	Seal fitted width B ₁	Design	Lip code	Designation
Shaft diameter range d ₁ over	incl.											
in.		mm	in.							-	-	-
0.530	0.610	14	0.490	0.120	0.130	0.220	0.080	0.350	0.180±0.020	VR1	R	CR 400140
		14	0.490	0.120	0.220	0.300	0.080	0.350	0.260±0.020	VR2	R	CR 400141
		14	0.490	0.120	0.130	0.220	0.080	0.350	0.180±0.020	VR1	V	CR 400144
		14	0.490	0.120	0.220	0.300	0.080	0.350	0.260±0.020	VR2	V	CR 400145
0.610	0.690	16	0.550	0.120	0.130	0.220	0.080	0.350	0.180±0.020	VR1	R	CR 400160
		16	0.550	0.120	0.220	0.300	0.080	0.350	0.260±0.020	VR2	R	CR 400161
		16	0.550	0.120	0.130	0.220	0.080	0.350	0.180±0.020	VR1	V	CR 400164
		16	0.550	0.120	0.220	0.300	0.080	0.350	0.260±0.020	VR2	V	CR 400165
0.690	0.750	18	0.630	0.120	0.130	0.220	0.080	0.350	0.180±0.020	VR1	R	CR 400180
		18	0.630	0.120	0.130	0.220	0.080	0.350	0.180±0.020	VR1	V	CR 400184
0.690	0.770	18	0.630	0.120	0.220	0.300	0.080	0.350	0.260±0.020	VR2	R	CR 400181
		18	0.630	0.120	0.220	0.300	0.080	0.350	0.260±0.020	VR2	V	CR 400185
0.750	0.830	20	0.710	0.160	0.190	0.300	0.080	0.470	0.240±0.030	VR1	R	CR 400200
		20	0.710	0.160	0.190	0.300	0.080	0.470	0.240±0.030	VR1	V	CR 400204
0.770	0.830	20	0.710	0.160	0.310	0.410	0.080	0.470	0.350±0.030	VR2	R	CR 400201
		20	0.710	0.160	0.310	0.410	0.080	0.470	0.350±0.030	VR2	V	CR 400205
0.830	0.950	22	0.790	0.160	0.190	0.300	0.080	0.470	0.240±0.030	VR1	R	CR 400220
		22	0.790	0.160	0.310	0.410	0.080	0.470	0.350±0.030	VR2	R	CR 400221
		22	0.790	0.160	0.190	0.300	0.080	0.470	0.240±0.030	VR1	V	CR 400224
		22	0.790	0.160	0.310	0.410	0.080	0.470	0.350±0.030	VR2	V	CR 400225
0.950	1.070	25	0.870	0.160	0.190	0.300	0.080	0.470	0.240±0.030	VR1	R	CR 400250
		25	0.870	0.160	0.310	0.410	0.080	0.470	0.350±0.030	VR2	R	CR 400251
		25	0.870	0.160	0.190	0.300	0.080	0.470	0.240±0.030	VR1	V	CR 400254
		25	0.870	0.160	0.310	0.410	0.080	0.470	0.350±0.030	VR2	V	CR 400255
1.070	1.140	28	0.980	0.160	0.190	0.300	0.120	0.470	0.240±0.030	VR1	R	CR 400280
		28	0.980	0.160	0.310	0.410	0.120	0.470	0.350±0.030	VR2	R	CR 400281
		28	0.980	0.160	0.190	0.300	0.120	0.470	0.240±0.030	VR1	V	CR 400284
		28	0.980	0.160	0.310	0.410	0.120	0.470	0.350±0.030	VR2	V	CR 400285
1.140	1.220	30	1.060	0.160	0.190	0.300	0.120	0.470	0.240±0.030	VR1	R	CR 400300
		30	1.060	0.160	0.310	0.410	0.120	0.470	0.350±0.030	VR2	R	CR 400301
		30	1.060	0.160	0.190	0.300	0.120	0.470	0.240±0.030	VR1	V	CR 400304
		30	1.060	0.160	0.310	0.410	0.120	0.470	0.350±0.030	VR2	V	CR 400305
1.220	1.300	32	1.140	0.160	0.190	0.300	0.120	0.470	0.240±0.030	VR1	R	CR 400320
		32	1.140	0.160	0.310	0.410	0.120	0.470	0.350±0.030	VR2	R	CR 400321
		32	1.140	0.160	0.190	0.300	0.120	0.470	0.240±0.030	VR1	V	CR 400324
		32	1.140	0.160	0.310	0.410	0.120	0.470	0.350±0.030	VR2	V	CR 400325
1.300	1.420	35	1.220	0.160	0.190	0.300	0.120	0.470	0.240±0.030	VR1	R	CR 400350
		35	1.220	0.160	0.310	0.410	0.120	0.470	0.350±0.030	VR2	R	CR 400351
		35	1.220	0.160	0.190	0.300	0.120	0.470	0.240±0.030	VR1	V	CR 400354
		35	1.220	0.160	0.310	0.410	0.120	0.470	0.350±0.030	VR2	V	CR 400355
1.420	1.500	38	1.340	0.160	0.190	0.300	0.120	0.470	0.240±0.030	VR1	R	CR 400380
		38	1.340	0.160	0.310	0.410	0.120	0.470	0.350±0.030	VR2	R	CR 400381
		38	1.340	0.160	0.190	0.300	0.120	0.470	0.240±0.030	VR1	V	CR 400384
		38	1.340	0.160	0.310	0.410	0.120	0.470	0.350±0.030	VR2	V	CR 400385
1.500	1.700	40	1.420	0.200	0.220	0.350	0.120	0.590	0.280±0.040	VR1	R	CR 400400
		40	1.420	0.200	0.370	0.510	0.120	0.590	0.430±0.040	VR2	R	CR 400401
		40	1.420	0.200	0.220	0.350	0.120	0.590	0.280±0.040	VR1	V	CR 400404
		40	1.420	0.200	0.370	0.510	0.120	0.590	0.430±0.040	VR2	V	CR 400405
1.700	1.890	45	1.570	0.200	0.220	0.350	0.120	0.590	0.280±0.040	VR1	R	CR 400450
		45	1.570	0.200	0.370	0.510	0.120	0.590	0.430±0.040	VR2	R	CR 400451
		45	1.570	0.200	0.220	0.350	0.120	0.590	0.280±0.040	VR1	V	CR 400454
		45	1.570	0.200	0.370	0.510	0.120	0.590	0.430±0.040	VR2	V	CR 400455

V-ring seals – inch dimensions, for North American market

d_1 1.890 – 6.890 in.

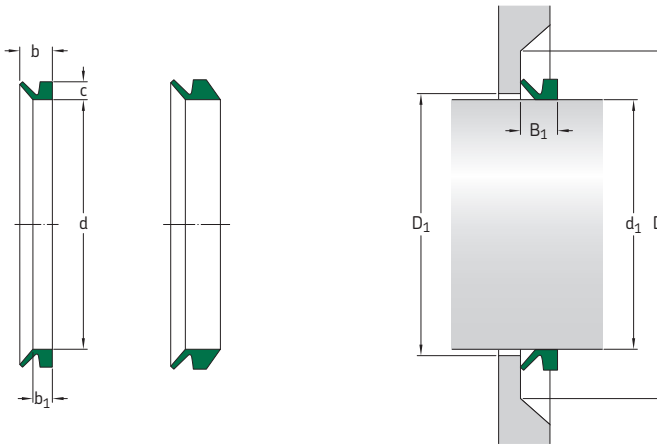

Dimensions		Ref. metric dim.	Seal inside diameter, free state d	Seal seat width b_1	Nominal seal width b	Nominal seal height c	Clearance D_1 max	Counter-face D min	Seal fitted width B_1	Design	Lip code	Designation
Shaft diameter range d_1 over	incl.											
in.		mm	in.							-	-	-
1.890	2.090	50	1.770	0.200	0.220	0.350	0.120	0.590	0.280±0.040	VR1	R	CR 400500
		50	1.770	0.200	0.370	0.510	0.120	0.590	0.430±0.040	VR2	R	CR 400501
		50	1.770	0.200	0.220	0.350	0.120	0.590	0.280±0.040	VR1	V	CR 400504
		50	1.770	0.200	0.370	0.510	0.120	0.590	0.430±0.040	VR2	V	CR 400505
2.090	2.290	55	1.930	0.200	0.220	0.350	0.120	0.590	0.280±0.040	VR1	R	CR 400550
		55	1.930	0.200	0.370	0.510	0.120	0.590	0.430±0.040	VR2	R	CR 400551
		55	1.930	0.200	0.220	0.350	0.120	0.590	0.280±0.040	VR1	V	CR 400554
		55	1.930	0.200	0.370	0.510	0.120	0.590	0.430±0.040	VR2	V	CR 400555
2.290	2.480	60	2.130	0.200	0.220	0.350	0.120	0.590	0.280±0.040	VR1	R	CR 400600
		60	2.130	0.200	0.370	0.510	0.120	0.590	0.430±0.040	VR2	R	CR 400601
		60	2.130	0.200	0.220	0.350	0.120	0.590	0.280±0.040	VR1	V	CR 400604
		60	2.130	0.200	0.370	0.510	0.120	0.590	0.430±0.040	VR2	V	CR 400605
2.480	2.680	65	2.280	0.200	0.220	0.350	0.120	0.590	0.280±0.040	VR1	R	CR 400650
		65	2.280	0.200	0.370	0.510	0.120	0.590	0.430±0.040	VR2	R	CR 400651
		65	2.280	0.200	0.220	0.350	0.120	0.590	0.280±0.040	VR1	V	CR 400654
		65	2.280	0.200	0.370	0.510	0.120	0.590	0.430±0.040	VR2	V	CR 400655
		65	2.280	0.200	0.220	0.350	0.120	0.590	0.280±0.040	VR1	R	CR 400659
2.680	2.880	70	2.480	0.240	0.270	0.430	0.160	0.710	0.350±0.050	VR1	R	CR 400700
		70	2.480	0.240	0.440	0.610	0.160	0.710	0.530±0.050	VR2	R	CR 400701
		70	2.480	0.240	0.270	0.430	0.160	0.710	0.350±0.050	VR1	V	CR 400704
		70	2.480	0.240	0.440	0.610	0.160	0.710	0.530±0.050	VR2	V	CR 400705
2.880	3.070	75	2.640	0.240	0.270	0.430	0.160	0.710	0.350±0.050	VR1	R	CR 400750
		75	2.640	0.240	0.440	0.610	0.160	0.710	0.530±0.050	VR2	R	CR 400751
		75	2.640	0.240	0.270	0.430	0.160	0.710	0.350±0.050	VR1	V	CR 400754
		75	2.640	0.240	0.440	0.610	0.160	0.710	0.530±0.050	VR2	V	CR 400755
3.070	3.270	80	2.830	0.240	0.270	0.430	0.160	0.710	0.350±0.050	VR1	R	CR 400800
		80	2.830	0.240	0.440	0.610	0.160	0.710	0.530±0.050	VR2	R	CR 400801
		80	2.830	0.240	0.270	0.430	0.160	0.710	0.350±0.050	VR1	V	CR 400804
		80	2.830	0.240	0.440	0.610	0.160	0.710	0.530±0.050	VR2	V	CR 400805

Select the larger V-ring when the dimension d_1 is on the boundary between two sizes of V-ring.

Dimensions		Ref. metric dim.	Seal inside diameter, free state d	Seal seat width b ₁	Nominal seal width b	Nominal seal height c	Clearance D ₁ max	Counter-face D min	Seal fitted width B ₁	Design	Lip code	Designation
Shaft diameter range d ₁ over	incl.											
in.		mm	in.							-	-	-
3.270	3.470	85	2.990	0.240	0.270	0.430	0.160	0.710	0.350±0.050	VR1	R	CR 400850
		85	2.940	0.240	0.440	0.610	0.160	0.710	0.530±0.050	VR2	R	CR 400851
		85	2.990	0.240	0.270	0.430	0.160	0.710	0.350±0.050	VR1	V	CR 400854
		85	2.940	0.240	0.440	0.610	0.160	0.710	0.530±0.050	VR2	V	CR 400855
3.470	3.660	90	3.190	0.240	0.270	0.430	0.160	0.710	0.350±0.050	VR1	R	CR 400900
		90	3.190	0.240	0.440	0.610	0.160	0.710	0.530±0.050	VR2	R	CR 400901
		90	3.190	0.240	0.270	0.430	0.160	0.710	0.350±0.050	VR1	V	CR 400904
		90	3.190	0.240	0.440	0.610	0.160	0.710	0.530±0.050	VR2	V	CR 400905
3.660	3.860	95	3.350	0.240	0.270	0.430	0.160	0.710	0.350±0.050	VR1	R	CR 400950
		95	3.350	0.240	0.440	0.610	0.160	0.710	0.530±0.050	VR2	R	CR 400951
		95	3.350	0.240	0.270	0.430	0.160	0.710	0.350±0.050	VR1	V	CR 400954
		95	3.350	0.240	0.440	0.610	0.160	0.710	0.530±0.050	VR2	V	CR 400955
3.860	4.140	100	3.540	0.240	0.270	0.430	0.160	0.710	0.350±0.050	VR1	R	CR 401000
		100	3.540	0.240	0.440	0.610	0.160	0.710	0.530±0.050	VR2	R	CR 401001
		100	3.540	0.240	0.270	0.430	0.160	0.710	0.350±0.050	VR1	V	CR 401004
		100	3.540	0.240	0.440	0.610	0.160	0.710	0.530±0.050	VR2	V	CR 401005
4.140	4.530	110	3.900	0.280	0.310	0.500	0.160	0.830	0.410±0.060	VR1	R	CR 401100
		110	3.900	0.280	0.520	0.710	0.160	0.830	0.610±0.060	VR2	R	CR 401101
		110	3.900	0.280	0.310	0.500	0.160	0.830	0.410±0.060	VR1	V	CR 401104
		110	3.900	0.280	0.520	0.710	0.160	0.830	0.610±0.060	VR2	V	CR 401105
4.530	4.920	120	4.250	0.280	0.310	0.500	0.160	0.830	0.410±0.060	VR1	R	CR 401200
		120	4.250	0.280	0.520	0.710	0.160	0.830	0.610±0.060	VR2	R	CR 401201
		120	4.250	0.260	0.240	0.410	0.200	0.800	0.315±0.060	VR3	V	CR 401202 ¹⁾
		120	4.250	0.280	0.310	0.500	0.160	0.830	0.410±0.060	VR1	V	CR 401204
		120	4.250	0.280	0.520	0.710	0.160	0.830	0.610±0.060	VR2	V	CR 401205
4.531	4.917	120	4.250	0.280	0.310	0.500	0.160	0.830	0.410±0.060	VR1	R	CR 401208
4.920	5.320	130	4.610	0.280	0.310	0.500	0.160	0.830	0.410±0.060	VR1	R	CR 401300
		130	4.610	0.280	0.520	0.710	0.160	0.830	0.610±0.060	VR2	R	CR 401301
		130	4.610	0.280	0.310	0.500	0.160	0.830	0.410±0.060	VR1	V	CR 401304
		130	4.610	0.280	0.520	0.710	0.160	0.830	0.610±0.060	VR2	V	CR 401305
5.320	5.710	140	4.960	0.280	0.310	0.500	0.160	0.830	0.410±0.060	VR1	R	CR 401400
		140	4.960	0.280	0.520	0.710	0.160	0.830	0.610±0.060	VR2	R	CR 401401
		140	4.960	0.260	0.240	0.410	0.200	0.800	0.310±0.060	VR3	R	CR 401402
		140	4.960	0.280	0.310	0.500	0.160	0.830	0.410±0.060	VR1	V	CR 401404
		140	4.960	0.280	0.520	0.710	0.160	0.830	0.610±0.060	VR2	V	CR 401405
		140	4.960	0.260	0.240	0.410	0.200	0.800	0.310±0.060	VR3	V	CR 401406
5.710	6.100	150	5.310	0.280	0.310	0.500	0.160	0.830	0.410±0.060	VR1	R	CR 401500
		150	5.310	0.280	0.520	0.710	0.160	0.830	0.610±0.060	VR2	R	CR 401501
		150	5.310	0.260	0.240	0.410	0.200	0.800	0.310±0.060	VR3	R	CR 401502
		150	5.310	0.280	0.310	0.500	0.160	0.830	0.410±0.060	VR1	V	CR 401504
		150	5.310	0.280	0.520	0.710	0.160	0.830	0.610±0.060	VR2	V	CR 401505
		150	5.310	0.260	0.240	0.410	0.200	0.800	0.310±0.060	VR3	V	CR 401506
6.100	6.500	160	5.670	0.310	0.350	0.570	0.200	0.940	0.470±0.070	VR1	R	CR 401600
		160	5.670	0.310	0.590	0.810	0.200	0.940	0.710±0.070	VR2	R	CR 401601
		160	5.670	0.260	0.240	0.410	0.200	0.800	0.310±0.060	VR3	R	CR 401602
		160	5.670	0.310	0.350	0.570	0.200	0.940	0.470±0.070	VR1	V	CR 401604
		160	5.670	0.310	0.590	0.810	0.200	0.940	0.710±0.070	VR2	V	CR 401605
		160	5.670	0.260	0.240	0.410	0.200	0.800	0.310±0.060	VR3	V	CR 401606
		160	5.670	0.310	0.350	0.570	0.200	0.940	0.470±0.070	VR1	R	CR 401608
		6.500	6.890	170	6.020	0.310	0.350	0.570	0.200	0.940	0.470±0.070	VR1
		170	6.020	0.310	0.590	0.810	0.200	0.940	0.710±0.070	VR2	R	CR 401701
		170	6.020	0.260	0.240	0.410	0.200	0.800	0.310±0.060	VR3	R	CR 401702
		170	6.020	0.310	0.350	0.570	0.200	0.940	0.470±0.070	VR1	V	CR 401704
		170	6.020	0.310	0.590	0.810	0.200	0.940	0.710±0.070	VR2	V	CR 401705
		170	6.020	0.260	0.240	0.410	0.200	0.800	0.310±0.060	VR3	V	CR 401706

¹⁾ Check for availability and pricing



V-ring seals – inch dimensions, for North American market
 d_1 6.890 – 18.700 in.

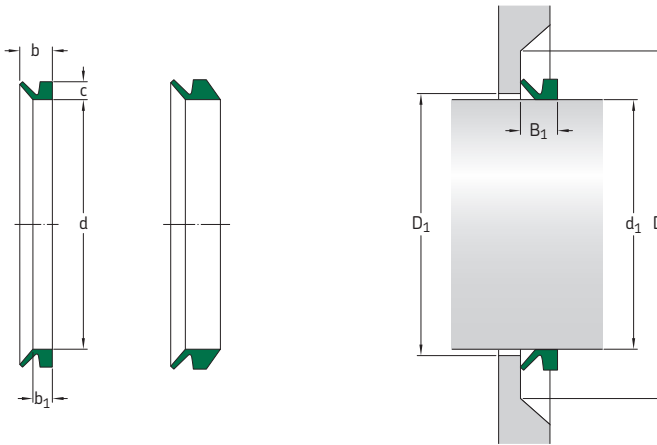

Dimensions		Ref. metric dim.	Seal inside diameter, free state d	Seal seat width b_1	Nominal seal width b	Nominal seal height c	Clearance D_1 max	Counter-face D min	Seal fitted width B_1	Design Lip code	Design-ation	
Shaft diameter range d_1 over	incl.											
in.	mm	mm	in.							-	-	
6.890	7.290	180	6.380	0.310	0.350	0.570	0.200	0.940	0.470±0.070	VR1	R	CR 401800
		180	6.380	0.310	0.590	0.810	0.200	0.940	0.710±0.070	VR2	R	CR 401801
		180	6.380	0.260	0.240	0.410	0.200	0.800	0.310±0.060	VR3	R	CR 401802
		180	6.380	0.310	0.350	0.570	0.200	0.940	0.470±0.070	VR1	V	CR 401804
		180	6.380	0.310	0.590	0.810	0.200	0.940	0.710±0.070	VR2	V	CR 401805
		180	6.380	0.260	0.240	0.410	0.200	0.800	0.310±0.060	VR3	V	CR 401806
7.290	7.680	190	6.730	0.310	0.350	0.570	0.200	0.940	0.470±0.070	VR1	R	CR 401900
		190	6.730	0.310	0.590	0.810	0.200	0.940	0.710±0.070	VR2	R	CR 401901
		190	6.730	0.260	0.240	0.410	0.200	0.800	0.310±0.060	VR3	R	CR 401902
		190	6.730	0.310	0.350	0.570	0.200	0.940	0.470±0.070	VR1	V	CR 401904
		190	6.730	0.310	0.590	0.810	0.200	0.940	0.710±0.070	VR2	V	CR 401905
		190	6.730	0.260	0.240	0.410	0.200	0.800	0.310±0.060	VR3	V	CR 401906
7.480	8.270	200	7.090	0.590	0.560	0.980	0.400	1.770	0.790±0.160	VR1	R	CR 402000
		200	7.090	0.590	0.560	0.980	0.400	1.770	0.790±0.160	VR1	V	CR 402004
7.680	8.270	199	7.090	0.310	0.350	0.570	0.200	0.940	0.470±0.070	VR1	R	CR 401990
		199	7.090	0.310	0.590	0.810	0.200	0.940	0.710±0.070	VR2	R	CR 401991
		199	7.090	0.310	0.350	0.570	0.200	0.940	0.470±0.070	VR1	V	CR 401994
		199	7.090	0.310	0.590	0.810	0.200	0.940	0.710±0.070	VR2	V	CR 401995
		200	7.170	0.260	0.240	0.410	0.200	0.800	0.310±0.060	VR3	R	CR 402002
		200	7.170	0.260	0.240	0.410	0.200	0.800	0.310±0.060	VR3	V	CR 402006
8.270	9.170	220	7.800	0.260	0.240	0.410	0.200	0.800	0.310±0.060	VR3	R	CR 402202
		220	7.800	0.260	0.240	0.410	0.200	0.800	0.310±0.060	VR3	V	CR 402206
8.270	9.250	220	7.800	0.590	0.560	0.980	0.400	1.770	0.790±0.160	VR1	R	CR 402200
		220	7.800	0.590	0.560	0.980	0.400	1.770	0.790±0.160	VR1	V	CR 402204
9.170	10.240	250	8.860	0.260	0.240	0.410	0.200	0.800	0.310±0.060	VR3	R	CR 402502
		250	8.860	0.260	0.240	0.410	0.200	0.800	0.310±0.060	VR3	V	CR 402506
9.250	10.430	250	8.860	0.590	0.560	0.980	0.400	1.770	0.790±0.160	VR1	R	CR 402500
		250	8.860	0.590	0.560	0.980	0.400	1.770	0.790±0.160	VR1	V	CR 402504
10.240	11.220	275	9.720	0.260	0.240	0.410	0.200	0.800	0.310±0.060	VR3	R	CR 402752
		275	9.720	0.260	0.240	0.410	0.200	0.800	0.310±0.060	VR3	V	CR 402756

Select the larger V-ring when the dimension d_1 is on the boundary between two sizes of V-ring.

Dimensions		Ref. metric dim.	Seal inside diameter, free state d	Seal seat width b ₁	Nominal seal width b	Nominal seal height c	Clearance D ₁ max	Counter-face D min	Seal fitted width B ₁	Design	Lip code	Designation
Shaft diameter range d ₁ over	incl.											
in.		mm	in.							-	-	-
10.430	11.420	275	9.720	0.590	0.560	0.980	0.400	1.770	0.790±0.160	VR1	R	CR 402750
		275	9.720	0.590	0.560	0.980	0.400	1.770	0.790±0.160	VR1	V	CR 402754
11.220	12.200	300	10.630	0.260	0.240	0.410	0.200	0.800	0.310±0.060	VR3	R	CR 403002
		300	10.630	0.260	0.240	0.410	0.200	0.800	0.310±0.060	VR3	V	CR 403006
11.420	12.200	300	10.630	0.590	0.560	0.980	0.400	1.770	0.790±0.160	VR1	R	CR 403000
		300	10.630	0.590	0.560	0.980	0.400	1.770	0.790±0.160	VR1	V	CR 403004
11.811	12.000	300	11.575	0.827	2.657	3.931	0.940	4.530	3.350±0.500	VR5	R	CR 470300¹⁾
12.200	13.190	325	11.500	0.590	0.560	0.980	0.400	1.770	0.790±0.160	VR1	R	CR 403250
		325	11.500	0.260	0.240	0.410	0.200	0.800	0.310±0.060	VR3	R	CR 403252
		325	11.500	0.590	0.560	0.980	0.400	1.770	0.790±0.160	VR1	V	CR 403254
		325	11.500	0.260	0.240	0.410	0.200	0.800	0.310±0.060	VR3	V	CR 403256
12.400	12.600	315	12.170	1.180	1.280	2.560	0.940	4.530	2.000±0.500	VR4	R	CR 403153¹⁾
13.190	14.370	350	12.400	0.590	0.560	0.980	0.400	1.770	0.790±0.160	VR1	R	CR 403500
		350	12.400	0.260	0.240	0.410	0.200	0.800	0.310±0.060	VR3	R	CR 403502
		350	12.400	0.590	0.560	0.980	0.400	1.770	0.790±0.160	VR1	V	CR 403504
		350	12.400	0.260	0.240	0.410	0.200	0.800	0.310±0.060	VR3	V	CR 403506
14.170	14.370	360	13.858	1.181	1.280	2.559	0.945	4.528	1.969±0.472	VR4	R	CR 403603
		360	13.858	1.180	1.280	2.560	0.940	4.530	2.000±0.500	VR4	V	CR 403607¹⁾
14.350	15.550	390	15.000	1.180	1.280	2.560	0.940	4.530	2.000±0.500	VR4	R	CR 403903¹⁾
14.370	15.150	375	13.270	0.260	0.240	0.410	0.200	0.800	0.310±0.060	VR3	R	CR 403752
		375	13.270	0.260	0.240	0.410	0.200	0.800	0.310±0.060	VR3	V	CR 403756
14.370	15.350	375	13.270	0.590	0.560	0.980	0.400	1.770	0.790±0.160	VR1	R	CR 403750
		375	13.270	0.590	0.560	0.980	0.400	1.770	0.790±0.160	VR1	V	CR 403754
14.567	14.764	370	14.252	1.180	1.280	2.560	0.940	4.530	2.000±0.500	VR4	R	CR 403703¹⁾
14.764	14.961	375	14.449	1.180	1.280	2.560	0.940	4.530	2.000±0.500	VR4	R	CR 403753¹⁾
14.961	15.157	380	14.606	0.827	2.657	3.937	0.940	4.530	3.350±0.500	VR5	R	CR 470380¹⁾
15.150	16.730	400	14.170	0.260	0.240	0.410	0.200	0.800	0.310±0.060	VR3	R	CR 404002
15.150	16.930	400	14.170	0.260	0.240	0.410	0.200	0.800	0.310±0.060	VR3	V	CR 404006
15.350	16.930	400	14.170	0.590	0.560	0.980	0.400	1.770	0.790±0.160	VR1	R	CR 404000
		400	14.170	0.590	0.560	0.980	0.400	1.770	0.790±0.160	VR1	V	CR 404004
15.354	19.685	385	14.803	0.827	2.657	3.937	0.940	4.530	3.350±0.500	VR5	R	CR 470385¹⁾
15.750	15.940	400	15.394	1.181	1.280	2.559	0.945	4.528	1.969±0.472	VR4	R	CR 404003
16.142	17.322	425	15.039	0.260	0.240	0.410	0.200	0.800	0.315±0.060	VR3	R	CR 404252¹⁾
16.730	18.700	450	15.940	0.260	0.240	0.410	0.200	0.800	0.310±0.060	VR3	R	CR 404502
		450	15.940	0.260	0.240	0.410	0.200	0.800	0.310±0.060	VR3	V	CR 404506
16.930	17.120	430	16.490	1.180	1.280	2.560	0.940	4.530	2.000±0.500	VR4	R	CR 404303
16.930	18.900	450	15.940	0.590	0.560	0.980	0.400	1.770	0.790±0.160	VR1	R	CR 404500
		450	15.940	0.590	0.560	0.980	0.400	1.770	0.790±0.160	VR1	V	CR 404504
17.720	17.910	450	17.280	1.180	1.280	2.560	0.940	4.530	2.000±0.500	VR4	R	CR 404503
18.110	18.310	460	17.640	1.180	1.280	2.560	0.940	4.530	5.000±0.500	VR4	R	CR 404603
18.500	18.700	470	18.030	1.180	1.280	2.560	0.940	4.530	2.000±0.500	VR4	R	CR 404703

¹⁾ Check for availability and pricing

V-ring seals – inch dimensions, for North American market

d_1 18.700 – 30.512 in.

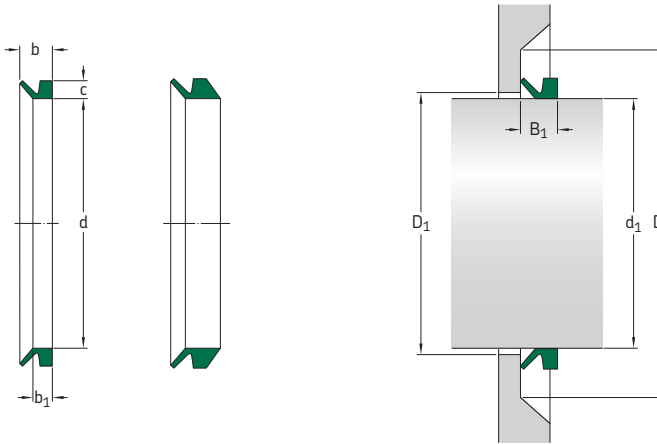

Dimensions		Ref. metric dim.	Seal inside diameter, free state d	Seal seat width b_1	Nominal seal width b	Nominal seal height c	Clearance D_1 max	Counter-face D min	Seal fitted width B_1	Design Lip code	Design-ation	
Shaft diameter range d_1 over	incl.											
in.	mm	in.										
18.700	18.900	475	18.228	1.180	1.280	2.560	0.940	4.530	2.000 ± 0.500	VR4	R	CR 404753 ¹⁾
	475	18.228	1.180	1.280	2.560	0.940	4.530	2.000 ± 0.500	VR4	V	CR 404754 ¹⁾	
18.700	20.080	500	17.717	0.255	0.236	0.413	0.196	0.787	0.315 ± 0.060	VR3	R	CR 405006
18.900	19.090	480	18.430	1.180	1.280	2.560	0.940	4.530	2.000 ± 0.500	VR4	R	CR 404803
	480	18.430	1.180	1.280	2.560	0.940	4.530	2.000 ± 0.500	VR4	V	CR 404807 ¹⁾	
18.900	20.870	500	17.720	0.590	0.560	0.980	0.400	1.770	0.790 ± 0.160	VR1	R	CR 405000
	500	17.720	0.260	0.240	0.410	0.200	0.800	0.310 ± 0.060	VR3	R	CR 405002	
	500	17.720	0.590	0.560	0.980	0.400	1.770	0.790 ± 0.160	VR1	V	CR 405004	
19.090	19.290	485	18.622	1.181	1.280	2.559	0.945	4.528	1.969 ± 0.472	VR4	R	CR 404853
19.100	19.290	485	19.094	1.180	1.280	2.560	0.940	4.530	2.000 ± 0.500	VR4	V	CR 404857 ¹⁾
19.290	19.490	490	18.820	1.180	1.280	2.560	0.940	4.530	2.000 ± 0.500	VR4	R	CR 404903
19.690	19.880	500	19.210	1.180	1.280	2.560	0.940	4.530	2.000 ± 0.500	VR4	R	CR 405003
	500	19.213	1.180	1.280	2.560	0.940	4.530	2.000 ± 0.500	VR4	V	CR 405007 ¹⁾	
19.910	18.110	455	17.480	1.180	1.280	2.560	0.940	4.530	2.000 ± 0.500	VR4	R	CR 404553
20.010	20.280	510	19.570	1.180	1.280	2.560	0.940	4.530	2.000 ± 0.500	VR4	R	CR 405103
20.080	21.260	525	18.580	0.260	0.240	0.410	0.200	0.800	0.310 ± 0.060	VR3	R	CR 405252
20.470	20.670	520	19.960	1.180	1.280	2.560	0.940	4.530	2.000 ± 0.500	VR4	R	CR 405203
20.870	21.060	530	20.350	1.180	1.280	2.560	0.940	4.530	2.000 ± 0.500	VR4	R	CR 405303
20.870	22.830	550	19.490	0.590	0.560	0.980	0.400	1.770	0.790 ± 0.160	VR1	R	CR 405500
	550	19.490	0.260	0.240	0.410	0.200	0.800	0.310 ± 0.060	VR3	R	CR 405502	
	550	19.490	0.590	0.560	0.980	0.400	1.770	0.790 ± 0.160	VR1	V	CR 405504	
21.260	21.460	540	20.709	1.180	1.280	2.560	0.940	4.530	2.000 ± 0.500	VR4	R	CR 405403 ¹⁾
21.560	22.638	550	19.488	0.260	0.240	0.410	0.200	0.800	0.315 ± 0.060	VR3	V	CR 405506 ¹⁾

Select the larger V-ring when the dimension d_1 is on the boundary between two sizes of V-ring.

¹⁾ Check for availability and pricing

Dimensions		Ref. metric dim.	Seal inside diameter, free state d	Seal seat width b ₁	Nominal seal width b	Nominal seal height c	Clearance D ₁ max	Counter-face D min	Seal fitted width B ₁	Design	Lip code	Designation
Shaft diameter range d ₁ over	incl.											
in.		mm	in.							-	-	-
21.650	21.850	550	21.100	1.180	1.280	2.560	0.940	4.530	2.000±0.500	VR4	R	CR 405503
22.050	22.240	560 560	21.496 21.496	1.181 1.180	1.280 1.280	2.559 2.560	0.945 0.940	4.528 4.530	1.969±0.472 2.000±0.500	VR4 VR4	R V	CR 405603 CR 405607¹⁾
22.440	22.640	570	21.850	1.180	1.280	2.560	0.940	4.530	2.000±0.500	VR4	R	CR 405703
22.638	22.835	575	22.047	1.180	1.280	2.560	0.940	4.530	2.000±0.500	VR4	V	CR 405757¹⁾
22.638	24.606	600	21.260	0.260	0.240	0.410	0.200	0.800	0.315±0.060	VR3	V	CR 406006¹⁾
22.640	22.830	575	22.050	1.180	1.280	2.560	0.940	4.530	2.000±0.500	VR4	R	CR 405753
22.830	23.030	580	22.240	1.180	1.280	2.560	0.940	4.530	2.000±0.500	VR4	R	CR 405803
22.830	24.800	600 600 600	21.260 21.260 21.260	0.590 0.260 0.590	0.560 0.240 0.560	0.980 0.410 0.980	0.400 0.200 0.400	1.770 0.800 1.770	0.790±0.160 0.310±0.060 0.790±0.160	VR1 VR3 VR1	R R V	CR 406000 CR 406002 CR 406004
23.230	23.620	590	22.640	1.180	1.280	2.560	0.940	4.530	2.000±0.500	VR4	R	CR 405903
23.620	24.020	600	22.910	1.180	1.280	2.560	0.940	4.530	2.000±0.500	VR4	R	CR 406003
24.020	24.410	610	23.310	1.180	1.280	2.560	0.940	4.530	2.000±0.500	VR4	R	CR 406103
24.410	24.800	620	23.700	1.180	1.280	2.560	0.940	4.530	2.000±0.500	VR4	R	CR 406203
24.790	26.187	650	23.622	0.590	0.560	0.980	0.400	1.770	0.790±0.160	VR1	V	CR 406504¹⁾
24.800	25.200	630	24.090	1.180	1.280	2.560	0.940	4.530	2.000±0.500	VR4	R	CR 406303
24.800	26.180	650	23.620	0.590	0.560	0.980	0.400	1.770	0.790±0.160	VR1	R	CR 406500
25.200	25.590	640	24.450	1.180	1.280	2.560	0.940	4.530	2.000±0.500	VR4	R	CR 406403
25.590	25.980	650 650	24.840 24.842	1.180 1.180	1.280 1.280	2.560 2.560	0.940 0.940	4.530 4.530	2.000±0.500 2.000±0.500	VR4 VR4	R V	CR 406503 CR 406507¹⁾
25.980	26.380	660	25.197	1.180	1.280	2.560	0.940	4.530	2.000±0.500	VR4	R	CR 406603¹⁾
26.180	27.760	700 700	24.800 24.803	0.590 0.590	0.560 0.560	0.980 0.980	0.400 0.400	1.770 1.770	0.790±0.160 0.790±0.160	VR1 VR1	R V	CR 407000 CR 407004¹⁾
26.380	26.770	670	25.591	1.180	1.280	2.560	0.940	4.530	2.000±0.500	VR4	N	CR 406703¹⁾
26.770	27.170	680	25.984	1.180	1.280	2.560	0.940	4.530	2.000±0.500	VR4	N	CR 406803¹⁾
27.170	27.560	690 690	26.380 26.378	1.180 1.180	1.280 1.280	2.560 2.560	0.940 0.940	4.530 4.530	2.000±0.500 2.000±0.500	VR4 VR4	R V	CR 406903 CR 406907¹⁾
27.560	27.950	700	26.780	1.180	1.280	2.560	0.940	4.530	2.000±0.500	VR4	R	CR 407003
27.760	29.330	725	26.380	0.590	0.560	0.980	0.400	1.770	0.790±0.160	VR1	R	CR 407250
27.953	28.346	710	27.126	1.180	1.280	2.560	0.940	4.530	2.000±0.500	VR4	R	CR 407103¹⁾
28.350	28.740	720	27.520	1.180	1.280	2.560	0.940	4.530	2.000±0.500	VR4	R	CR 407203¹⁾
28.740	29.134	730 730	27.910 27.913	1.180 1.180	1.280 1.280	2.560 2.560	0.940 0.940	4.530 4.530	2.000±0.500 2.500±0.500	VR4 VR4	R V	CR 407303 CR 407307¹⁾
29.130	29.530	740	28.270	1.180	1.280	2.560	0.940	4.530	2.000±0.500	VR4	R	CR 407403
29.134	30.512	750	29.528	0.260	0.240	0.410	0.200	0.800	0.315±0.060	VR3	R	CR 407502¹⁾

¹⁾ Check for availability and pricing



V-ring seals – inch dimensions, for North American market

d_1 29.330 – 52.760 in.

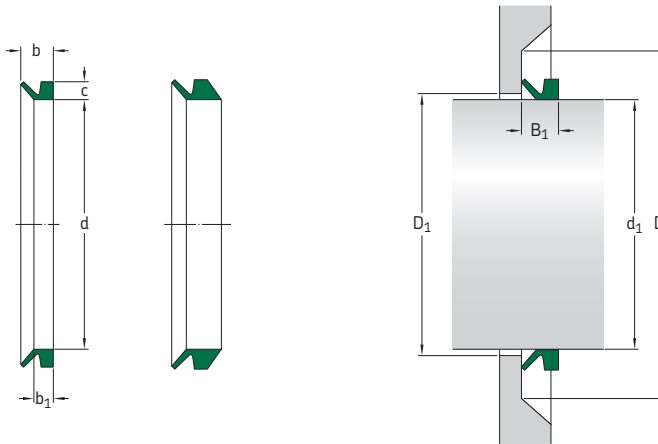

Dimensions		Ref. metric dim.	Seal inside diameter, free state d	Seal seat width b_1	Nominal seal width b	Nominal seal height c	Clearance D_1 max	Counter-face D min	Seal fitted width B_1	Design	Lip code	Designation
Shaft diameter range d_1 over	incl.											
in.	mm	in.								-	-	-
29.330	30.900	750	27.756	0.590	0.560	0.980	0.400	1.770	0.790±0.160	VR1	V	CR 407504 ¹⁾
29.330	30.910	750	27.760	0.590	0.560	0.980	0.400	1.770	0.790±0.160	VR1	R	CR 407500
29.530	29.840	750	28.660	1.180	1.280	2.560	0.940	4.530	2.000±0.500	VR4	R	CR 407503
29.845	30.157	760	28.937	1.181	1.280	2.559	0.945	4.528	1.969±0.472	VR4	R	CR 407603
30.157	30.472	770	29.250	1.181	1.280	2.559	0.945	4.528	1.969±0.472	VR4	R	CR 407703
30.470	30.830	780	29.570	1.180	1.280	2.560	0.940	4.530	2.000±0.500	VR4	R	CR 407803
30.900	32.680	800	29.330	0.590	0.560	0.980	0.400	1.770	0.790±0.160	VR1	V	CR 408004 ¹⁾
30.910	32.680	800	29.330	0.590	0.560	0.980	0.400	1.770	0.790±0.160	VR1	R	CR 408000
31.180	31.540	800	30.240	1.180	1.280	2.560	0.940	4.530	2.000±0.500	VR4	R	CR 408003
32.680	34.450	850	30.910	0.590	0.560	0.980	0.400	1.770	0.790±0.160	VR1	R	CR 408500
32.720	33.110	840	31.693	1.181	1.280	2.560	0.940	4.530	2.500±0.500	VR4	R	CR 408403 ¹⁾
33.110	33.500	850	32.050	1.180	1.280	2.560	0.940	4.530	2.000±0.500	VR4	R	CR 408503
33.900	34.290	870	32.795	1.180	1.280	2.560	0.940	4.530	2.000±0.500	VR4	R	CR 408703 ¹⁾
34.290	34.720	880	33.189	1.180	1.280	2.560	0.940	4.530	2.000±0.500	VR4	R	CR 408803 ¹⁾
		880	33.189	1.180	1.280	2.560	0.940	4.530	2.000±0.500	VR4	V	CR 408807 ¹⁾
34.449	36.417	900	32.480	0.260	0.240	0.410	0.200	0.800	0.315±0.060	VR3	R	CR 409002 ¹⁾
34.450	36.220	890	33.583	1.180	1.280	2.560	0.940	4.530	2.000±0.500	VR4	V	CR 408907 ¹⁾
		900	32.480	0.590	0.560	0.980	0.400	1.770	0.790±0.160	VR1	R	CR 409000
		900	32.480	0.590	0.560	0.980	0.400	1.770	0.790±0.160	VR1	V	CR 409004 ¹⁾
34.720	35.310	890	33.580	1.180	1.280	2.560	0.940	4.530	2.000±0.500	VR4	R	CR 408903
35.118	35.905	900	34.291	0.827	2.657	3.937	0.940	4.530	3.350±0.500	VR5	R	CR 470900 ¹⁾

Select the larger V-ring when the dimension d_1 is on the boundary between two sizes of V-ring.

¹⁾ Check for availability and pricing

Dimensions		Ref. metric dim.	Seal inside diameter, free state d	Seal seat width b ₁	Nominal seal width b	Nominal seal height c	Clearance D ₁ max	Counter-face D min	Seal fitted width B ₁	Design	Lip code	Designation
Shaft diameter range d ₁ over	incl.											
in.		mm	in.							-	-	-
35.310	35.910	900	34.290	1.180	1.280	2.560	0.940	4.530	2.000±0.500	VR4	R	CR 409003
36.220	37.990	950	34.060	0.590	0.560	0.980	0.400	1.770	0.790±0.160	VR1	R	CR 409500
36.220	37.992	950	34.055	0.590	0.560	0.980	0.400	1.770	0.790±0.160	VR1	V	CR 409504¹⁾
36.730	31.170	940	35.433	0.827	2.657	3.937	0.940	4.530	3.350±0.500	VR5	R	CR 470940¹⁾
36.732	37.165	940	35.433	1.180	1.280	2.560	0.940	4.530	2.000±0.500	VR4	R	CR 409403¹⁾
37.170	37.600	950	35.870	1.180	1.280	2.560	0.940	4.530	2.000±0.500	VR4	R	CR 409503
37.990	39.960	1 000	35.830	0.590	0.560	0.980	0.400	1.770	0.790±0.160	VR1	R	CR 410000
		1 000	35.827	0.590	0.560	0.980	0.400	1.770	0.790±0.160	VR1	V	CR 410004¹⁾
38.898	39.331	990	37.520	1.180	1.280	2.560	0.940	4.530	2.000±0.500	VR4	R	CR 409903¹⁾
39.330	39.760	1 000	37.910	1.180	1.280	2.560	0.940	4.530	2.000±0.500	VR4	R	CR 410003
39.960	41.930	1 050	37.600	0.590	0.560	0.980	0.400	1.770	0.790±0.160	VR1	R	CR 410500
40.550	41.350	1 050	39.340	1.180	1.280	2.560	0.940	4.530	2.000±0.500	VR4	R	CR 410503
41.140	41.930	1 060	39.690	1.180	1.280	2.560	0.940	4.530	2.000±0.500	VR4	R	CR 410603
41.930	42.720	1 080	40.433	1.180	1.280	2.560	0.940	4.530	2.000±0.500	VR4	R	CR 410803¹⁾
41.930	43.900	1 100	39.370	0.590	0.560	0.980	0.400	1.770	0.790±0.160	VR1	R	CR 411000
42.720	43.500	1 100	41.140	1.180	1.280	2.560	0.940	4.530	2.000±0.500	VR4	R	CR 411003
43.500	44.290	1 120	41.929	1.180	1.280	2.560	0.940	4.530	2.000±0.500	VR4	R	CR 411203¹⁾
43.900	45.870	1 150	41.140	0.590	0.560	0.980	0.400	1.770	0.790±0.160	VR1	R	CR 411500
44.290	46.260	1 150	41.142	0.260	0.240	0.410	0.200	0.800	0.315±0.060	VR3	R	CR 411502¹⁾
44.291	45.079	1 140	42.677	0.827	2.657	3.937	0.940	4.530	3.350±0.500	VR5	R	CR 471140¹⁾
44.490	45.290	1 150	43.060	1.180	1.280	2.560	0.940	4.530	2.000±0.500	VR4	R	CR 411503
45.870	46.650	1 180	44.134	1.180	1.280	2.560	0.940	4.530	2.000±0.500	VR4	R	CR 411803¹⁾
45.870	47.840	1 200	42.910	0.590	0.560	0.980	0.400	1.770	0.790±0.160	VR1	R	CR 412000
45.875	47.840	1 200	42.913	0.590	0.560	0.980	0.400	1.770	0.790±0.160	VR1	V	CR 412004¹⁾
46.259	48.238	1 200	42.913	0.260	0.240	0.410	0.200	0.800	0.315±0.060	VR3	R	CR 412002¹⁾
46.650	47.440	1 200	44.840	1.180	1.280	2.560	0.940	4.530	2.000±0.500	VR4	R	CR 412003
47.840	50.000	1 250	44.690	0.590	0.560	0.980	0.400	1.770	0.790±0.160	VR1	R	CR 412500
		1 250	44.685	0.590	0.560	0.980	0.400	1.770	0.790±0.160	VR1	V	CR 412504¹⁾
48.230	49.020	1 240	46.299	1.180	1.280	2.560	0.940	4.530	2.000±0.500	VR4	R	CR 412403¹⁾
48.520	49.320	1 250	46.680	1.180	1.280	2.560	0.940	4.530	2.000±0.500	VR4	R	CR 412503
50.000	50.890	1 250	47.953	1.180	1.280	2.560	0.940	4.530	2.000±0.500	VR4	R	CR 412803¹⁾
50.000	51.970	1 300	46.460	0.590	0.560	0.980	0.400	1.770	0.790±0.160	VR1	R	CR 413000
50.980	51.770	1 300	48.820	1.180	1.280	2.560	0.940	4.530	2.000±0.500	VR4	R	CR 413003
51.770	52.760	1 325	49.567	1.180	1.280	2.560	0.940	4.530	2.000±0.500	VR4	R	CR 413253¹⁾

¹⁾ Check for availability and pricing



V-ring seals – inch dimensions, for North American market

d_1 51.970 – 131.890 in.

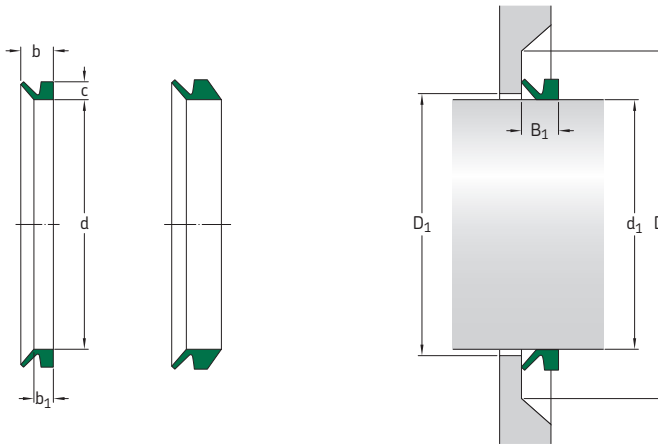

Dimensions		Ref. metric dim.	Seal inside diameter, free state d	Seal seat width b_1	Nominal seal width b	Nominal seal height c	Clearance D_1 max	Counter-face D min	Seal fitted width B_1	Design	Lip code	Designation
Shaft diameter range d_1 over	incl.											
in.	mm	in.								-	-	-
51.970	53.940	1350	48.230	0.590	0.560	0.980	0.400	1.770	0.790±0.160	VR1	R	CR 413500
52.165	54.134	1350	48.228	0.260	0.240	0.410	0.200	0.800	0.315±0.060	VR3	R	CR 413502 ¹⁾
52.760	53.740	1350	50.430	1.180	1.280	2.560	0.940	4.530	2.000±0.500	VR4	R	CR 413503
53.940	55.910	1400	50.000	0.590	0.560	0.980	0.400	1.770	0.790±0.160	VR1	R	CR 414000
54.130	56.100	1400	50.000	0.260	0.240	0.410	0.200	0.800	0.315±0.060	VR3	V	CR 414006 ¹⁾
54.720	55.710	1400	52.280	1.180	1.280	2.560	0.940	4.530	2.000±0.500	VR4	R	CR 414003
55.190	57.870	1450	51.772	0.590	0.560	0.980	0.400	1.770	0.790±0.160	VR1	V	CR 414504 ¹⁾
55.910	57.870	1450	51.770	0.590	0.560	0.980	0.400	1.770	0.790±0.160	VR1	R	CR 414500
56.690	57.680	1450	54.090	1.180	1.280	2.560	0.940	4.530	2.000±0.500	VR4	R	CR 414503
57.870	59.840	1500	53.540	0.590	0.560	0.980	0.400	1.770	0.790±0.160	VR1	R	CR 415000
58.660	59.650	1500	55.870	1.180	1.280	2.560	0.940	4.530	2.000±0.500	VR4	R	CR 415003
59.840	61.810	1550	55.320	0.590	0.560	0.980	0.400	1.770	0.790±0.160	VR1	R	CR 415500
60.630	61.810	1550	57.760	1.180	1.280	2.560	0.940	4.530	2.000±0.500	VR4	R	CR 415503
61.810	63.780	1600	57.090	0.590	0.560	0.980	0.400	1.770	0.790±0.160	VR1	R	CR 416000
62.990	64.570	1600	60.000	1.180	1.280	2.560	0.940	4.530	2.000±0.500	VR4	R	CR 416003
63.780	65.750	1650	58.860	0.590	0.560	0.980	0.400	1.770	0.790±0.160	VR1	R	CR 416500
64.570	66.140	1650	61.380	1.180	1.280	2.560	0.940	4.530	2.000±0.500	VR4	R	CR 416503
65.750	67.720	1700	60.630	0.590	0.560	0.980	0.400	1.770	0.790±0.160	VR1	R	CR 417000
66.140	67.720	1700	62.830	1.180	1.280	2.560	0.940	4.530	2.000±0.500	VR4	R	CR 417003

Select the larger V-ring when the dimension d_1 is on the boundary between two sizes of V-ring.

¹⁾ Check for availability and pricing

Dimensions		Ref. metric dim.	Seal inside diameter, free state d	Seal seat width b ₁	Nominal seal width b	Nominal seal height c	Clearance D ₁ max	Counter-face D min	Seal fitted width B ₁	Design	Lip code	Designation
Shaft diameter range d ₁ over	incl.											
in.		mm	in.							-	-	-
67.720	69.490	1750	64.250	1.180	1.280	2.560	0.940	4.530	2.000±0.500	VR4	R	CR 417503
67.720	69.690	1750	62.400	0.590	0.560	0.980	0.400	1.770	0.790±0.160	VR1	R	CR 417500
69.490	71.260	1800	65.790	1.180	1.280	2.560	0.940	4.530	2.000±0.500	VR4	R	CR 418003
69.690	71.560	1800	64.170	0.590	0.560	0.980	0.400	1.770	0.790±0.160	VR1	R	CR 418000
69.880	71.850	1800	64.173	0.260	0.240	0.410	0.200	0.800	0.315±0.060	VR3	V	CR 418006¹⁾
71.260	73.030	1850	67.480	1.180	1.280	2.560	0.940	4.530	2.000±0.500	VR4	R	CR 418503
71.650	73.620	1850	65.950	0.590	0.560	0.980	0.400	1.770	0.790±0.160	VR1	R	CR 418500
73.030	75.000	1900	69.020	1.180	1.280	2.560	0.940	4.530	2.000±0.500	VR4	R	CR 419003
73.620	75.590	1900	67.720	0.590	0.560	0.980	0.400	1.770	0.790±0.160	VR1	R	CR 419000
75.000	76.970	1950	70.630	1.180	1.280	2.560	0.940	4.530	2.000±0.500	VR4	R	CR 419503
75.590	77.560	1950	69.490	0.590	0.560	0.980	0.400	1.770	0.790±0.160	VR1	R	CR 419500
76.970	79.130	2000	72.600	1.180	1.280	2.560	0.940	4.530	2.000±0.500	VR4	R	CR 419993
77.560	79.530	2000	71.260	0.590	0.560	0.980	0.400	1.770	0.790±0.160	VR1	R	CR 419990
79.530	83.460	2100	72.240	0.590	0.560	0.980	0.400	1.770	0.790±0.160	VR1	R	CR 421000¹⁾
83.360	86.420	2150	78.660	1.180	1.280	2.560	0.940	4.530	2.000±0.520	VR4	R	CR 421503¹⁾
86.419	89.209	2200	80.905	0.827	2.657	3.937	0.940	4.530	3.350±0.500	VR5	R	CR 472201¹⁾
96.063	100.000	2500	89.520	1.180	1.280	2.560	0.940	4.530	2.000±0.500	VR4	R	CR 425003¹⁾
97.358	99.543	2500	86.020	0.590	0.560	0.980	0.400	1.770	0.790±0.160	VR1	R	CR 425000¹⁾
126.260	129.670	3250	113.740	1.180	1.280	2.560	0.940	4.530	2.00±0.500	VR4	R	CR 432503¹⁾
127.950	131.890	3300	115.390	1.180	1.280	2.560	0.940	4.530	2.00±0.500	VR4	R	CR 433003¹⁾

¹⁾ Check for availability and pricing



V-ring seals – metric dimensions, globally valid outside North American market

d_1 2,7 – 48 mm

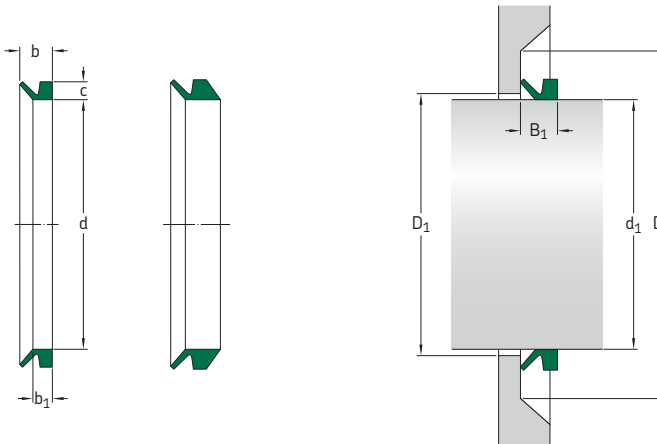

Dimensions		Seal inside diameter, free state d	Seal seat width b_1	Nominal seal width b	Nominal seal height c	Clearance D_1 max	Counterface D min	Seal fitted width B_1	Lip code	Designation
Shaft diameter range d_1 over	incl.									
mm										
2,7	3,5	2,5	2,1	3	1,5	d_1+1	d_1+4	$2,5 \pm 0,3$	R	3 VA R
		2,5	2,1	3	1,5	d_1+1	d_1+4	$2,5 \pm 0,3$	V	3 VAV
3,5	4,5	3,2	2,4	3,7	2	d_1+1	d_1+6	$3,0 \pm 0,4$	R	4 VA R
		3,2	2,4	3,7	2	d_1+1	d_1+6	$3,0 \pm 0,4$	V	4 VAV
4,5	5,5	4	2,4	3,7	2	d_1+1	d_1+6	$3,0 \pm 0,4$	R	5 VA R
		4	2,4	3,7	2	d_1+1	d_1+6	$3,0 \pm 0,4$	V	5 VAV
		4	3,9	5,2	2	d_1+1	d_1+6	$4,5 \pm 0,4$	R	5 VS R
		4	3,9	5,2	2	d_1+1	d_1+6	$4,5 \pm 0,4$	V	5 VSV
5,5	6,5	5	2,4	3,7	2	d_1+1	d_1+6	$3,0 \pm 0,4$	R	6 VA R
		5	2,4	3,7	2	d_1+1	d_1+6	$3,0 \pm 0,4$	V	6 VAV
		5	3,9	5,2	2	d_1+1	d_1+6	$4,5 \pm 0,4$	R	6 VS R
		5	3,9	5,2	2	d_1+1	d_1+6	$4,5 \pm 0,4$	V	6 VSV
6,5	8,0	6	2,4	3,7	2	d_1+1	d_1+6	$3,0 \pm 0,4$	R	7 VA R
		6	2,4	3,7	2	d_1+1	d_1+6	$3,0 \pm 0,4$	V	7 VAV
		6	3,9	5,2	2	d_1+1	d_1+6	$4,5 \pm 0,4$	R	7 VS R
		6	3,9	5,2	2	d_1+1	d_1+6	$4,5 \pm 0,4$	V	7 VSV
8,0	9,5	7	2,4	3,7	2	d_1+1	d_1+6	$3,0 \pm 0,4$	R	8 VA R
		7	2,4	3,7	2	d_1+1	d_1+6	$3,0 \pm 0,4$	V	8 VAV
		7	3,9	5,2	2	d_1+1	d_1+6	$4,5 \pm 0,4$	R	8 VS R
		7	3,9	5,2	2	d_1+1	d_1+6	$4,5 \pm 0,4$	V	8 VSV
9,5	11,5	9	3,4	5,5	3	d_1+1	d_1+9	$4,5 \pm 0,6$	R	10 VA R
		9	3,4	5,5	3	d_1+1	d_1+9	$4,5 \pm 0,6$	V	10 VAV
		9	5,6	7,7	3	d_1+1	d_1+9	$6,7 \pm 0,6$	R	10 VS R
		9	5,6	7,7	3	d_1+1	d_1+9	$6,7 \pm 0,6$	V	10 VSV
11,5	12,5	10,5	3,4	5,5	3	d_1+1	d_1+9	$4,5 \pm 0,6$	R	12 VA R
		10,5	3,4	5,5	3	d_1+1	d_1+9	$4,5 \pm 0,6$	V	12 VAV
11,5	13,5	10,5	5,6	7,7	3	d_1+1	d_1+9	$6,7 \pm 0,6$	R	12 VS R
		10,5	5,6	7,7	3	d_1+1	d_1+9	$6,7 \pm 0,6$	V	12 VSV
12,5	13,5	11,7	3,4	5,5	3	d_1+1	d_1+9	$4,5 \pm 0,6$	R	13 VA R
		11,7	3,4	5,5	3	d_1+1	d_1+9	$4,5 \pm 0,6$	V	13 VAV

Select the larger V-ring when the dimension d_1 is on the boundary between two sizes of V-ring.

Dimensions		Seal inside diameter, free state d	Seal seat width b ₁	Nominal seal width b	Nominal seal height c	Clearance D ₁ max	Counterface D min	Seal fitted width B ₁	Lip code	Designation
Shaft diameter range d ₁ over	incl.									
mm										
13,5	15,5	12,5	3,4	5,5	3	d ₁ +1	d ₁ +9	4,5±0,6	R	14 VA R
		12,5	3,4	5,5	3	d ₁ +1	d ₁ +9	4,5±0,6	V	14 VA V
		12,5	5,6	7,7	3	d ₁ +1	d ₁ +9	6,7±0,6	R	14 VS R
		12,5	5,6	7,7	3	d ₁ +1	d ₁ +9	6,7±0,6	V	14 VS V
15,5	17	14	3,4	5,5	3	d ₁ +1	d ₁ +9	4,5±0,6	R	16 VA R
		14	3,4	5,5	3	d ₁ +1	d ₁ +9	4,5±0,6	V	16 VA V
15,5	17,5	14	5,6	7,7	3	d ₁ +1	d ₁ +9	6,7±0,6	R	16 VS R
		14	5,6	7,7	3	d ₁ +1	d ₁ +9	6,7±0,6	V	16 VS V
17,5	19	16	3,4	5,5	3	d ₁ +1	d ₁ +9	4,5±0,6	R	18 VA R
		16	3,4	5,5	3	d ₁ +1	d ₁ +9	4,5±0,6	V	18 VA V
		16	5,6	7,7	3	d ₁ +1	d ₁ +9	6,7±0,6	R	18 VS R
		16	5,6	7,7	3	d ₁ +1	d ₁ +9	6,7±0,6	V	18 VS V
19	21	18	4,7	7,5	4	d ₁ +2	d ₁ +12	6,0±0,8	R	20 VA R
		18	4,7	7,5	4	d ₁ +2	d ₁ +12	6,0±0,8	V	20 VA V
		18	7,9	10,5	4	d ₁ +2	d ₁ +12	9,0±0,8	R	20 VS R
		18	7,9	10,5	4	d ₁ +2	d ₁ +12	9,0±0,8	V	20 VS V
21	24	20	4,7	7,5	4	d ₁ +2	d ₁ +12	6,0±0,8	R	22 VA R
		20	4,7	7,5	4	d ₁ +2	d ₁ +12	6,0±0,8	V	22 VA V
		20	7,9	10,5	4	d ₁ +2	d ₁ +12	9,0±0,8	R	22 VS R
		20	7,9	10,5	4	d ₁ +2	d ₁ +12	9,0±0,8	V	22 VS V
24	27	22	4,7	7,5	4	d ₁ +2	d ₁ +12	6,0±0,8	R	25 VA R
		22	4,7	7,5	4	d ₁ +2	d ₁ +12	6,0±0,8	V	25 VA V
		22	7,9	10,5	4	d ₁ +2	d ₁ +12	9,0±0,8	R	25 VS R
		22	7,9	10,5	4	d ₁ +2	d ₁ +12	9,0±0,8	V	25 VS V
27	29	25	4,7	7,5	4	d ₁ +2	d ₁ +12	6,0±0,8	R	28 VA R
		25	4,7	7,5	4	d ₁ +2	d ₁ +12	6,0±0,8	V	28 VA V
		25	7,9	10,5	4	d ₁ +2	d ₁ +12	9,0±0,8	R	28 VS R
		25	7,9	10,5	4	d ₁ +2	d ₁ +12	9,0±0,8	V	28 VS V
29	31	27	4,7	7,5	4	d ₁ +2	d ₁ +12	6,0±0,8	R	30 VA R
		27	4,7	7,5	4	d ₁ +2	d ₁ +12	6,0±0,8	V	30 VA V
		27	7,9	10,5	4	d ₁ +2	d ₁ +12	9,0±0,8	R	30 VS R
		27	7,9	10,5	4	d ₁ +2	d ₁ +12	9,0±0,8	V	30 VS V
31	33	29	4,7	7,5	4	d ₁ +2	d ₁ +12	6,0±0,8	R	32 VA R
		29	4,7	7,5	4	d ₁ +2	d ₁ +12	6,0±0,8	V	32 VA V
		29	7,9	10,5	4	d ₁ +2	d ₁ +12	9,0±0,8	R	32 VS R
		29	7,9	10,5	4	d ₁ +2	d ₁ +12	9,0±0,8	V	32 VS V
33	36	31	4,7	7,5	4	d ₁ +2	d ₁ +12	6,0±0,8	R	35 VA R
		31	4,7	7,5	4	d ₁ +2	d ₁ +12	6,0±0,8	V	35 VA V
		31	7,9	10,5	4	d ₁ +2	d ₁ +12	9,0±0,8	R	35 VS R
		31	7,9	10,5	4	d ₁ +2	d ₁ +12	9,0±0,8	V	35 VS V
36	38	34	4,7	7,5	4	d ₁ +2	d ₁ +12	6,0±0,8	R	38 VA R
		34	4,7	7,5	4	d ₁ +2	d ₁ +12	6,0±0,8	V	38 VA V
		34	7,9	10,5	4	d ₁ +2	d ₁ +12	9,0±0,8	R	38 VS R
		34	7,9	10,5	4	d ₁ +2	d ₁ +12	9,0±0,8	V	38 VS V
38	43	36	5,5	9	5	d ₁ +2	d ₁ +15	7,0±1	R	40 VA R
		36	5,5	9	5	d ₁ +2	d ₁ +15	7,0±1	V	40 VA V
		36	9,5	13	5	d ₁ +2	d ₁ +15	11,0±1	R	40 VS R
		36	9,5	13	5	d ₁ +2	d ₁ +15	11,0±1	V	40 VS V
43	48	40	5,5	9	5	d ₁ +2	d ₁ +15	7,0±1	R	45 VA R
		40	5,5	9	5	d ₁ +2	d ₁ +15	7,0±1	V	45 VA V
		40	9,5	13	5	d ₁ +2	d ₁ +15	11,0±1	R	45 VS R
		40	9,5	13	5	d ₁ +2	d ₁ +15	11,0±1	V	45 VS V

7.2

V-ring seals – metric dimensions, globally valid outside North American market

d_1 48 – 175 mm

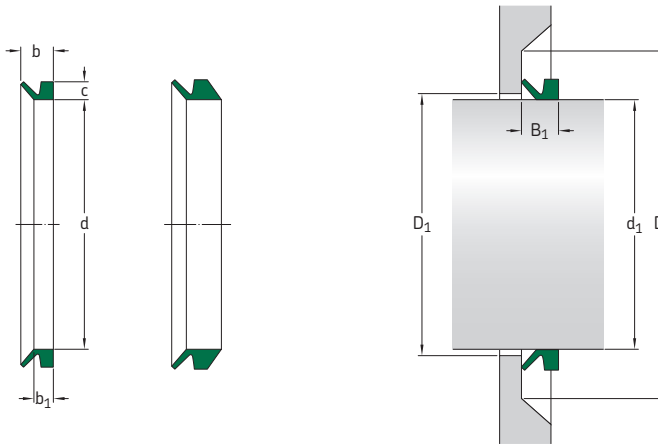

Dimensions		Seal inside diameter, free state d	Seal seat width b_1	Nominal seal width b	Nominal seal height c	Clearance D_1 max	Counterface D min	Seal fitted width B_1	Lip code	Designation
Shaft diameter range d_1 over	incl.									
mm										
48	53	45	5,5	9	5	$d_1 + 2$	$d_1 + 15$	$7,0 \pm 1$	R	50 VA R
		45	5,5	9	5	$d_1 + 2$	$d_1 + 15$	$7,0 \pm 1$	V	50 VA V
		45	9,5	13	5	$d_1 + 2$	$d_1 + 15$	$11,0 \pm 1$	R	50 VS R
		45	9,5	13	5	$d_1 + 2$	$d_1 + 15$	$11,0 \pm 1$	V	50 VS V
53	58	49	5,5	9	5	$d_1 + 2$	$d_1 + 15$	$7,0 \pm 1$	R	55 VA R
		49	5,5	9	5	$d_1 + 2$	$d_1 + 15$	$7,0 \pm 1$	V	55 VA V
		49	9,5	13	5	$d_1 + 2$	$d_1 + 15$	$11,0 \pm 1$	R	55 VS R
		49	9,5	13	5	$d_1 + 2$	$d_1 + 15$	$11,0 \pm 1$	V	55 VS V
58	63	54	5,5	9	5	$d_1 + 2$	$d_1 + 15$	$7,0 \pm 1$	R	60 VA R
		54	5,5	9	5	$d_1 + 2$	$d_1 + 15$	$7,0 \pm 1$	V	60 VA V
		54	9,5	13	5	$d_1 + 2$	$d_1 + 15$	$11,0 \pm 1$	R	60 VS R
		54	9,5	13	5	$d_1 + 2$	$d_1 + 15$	$11,0 \pm 1$	V	60 VS V
63	68	58	5,5	9	5	$d_1 + 2$	$d_1 + 15$	$7,0 \pm 1$	R	65 VA R
		58	5,5	9	5	$d_1 + 2$	$d_1 + 15$	$7,0 \pm 1$	V	65 VA V
		58	9,5	13	5	$d_1 + 2$	$d_1 + 15$	$11,0 \pm 1$	R	65 VS R
		58	9,5	13	5	$d_1 + 2$	$d_1 + 15$	$11,0 \pm 1$	V	65 VS V
68	73	63	6,8	11	6	$d_1 + 3$	$d_1 + 18$	$9,0 \pm 1,2$	R	70 VA R
		63	6,8	11	6	$d_1 + 3$	$d_1 + 18$	$9,0 \pm 1,2$	V	70 VA V
		63	11,3	15,5	6	$d_1 + 3$	$d_1 + 18$	$13,5 \pm 1,2$	R	70 VS R
		63	11,3	15,5	6	$d_1 + 3$	$d_1 + 18$	$13,5 \pm 1,2$	V	70 VS V
73	78	67	6,8	11	6	$d_1 + 3$	$d_1 + 18$	$9,0 \pm 1,2$	R	75 VA R
		67	6,8	11	6	$d_1 + 3$	$d_1 + 18$	$13,5 \pm 1,2$	R	75 VS R
		67	11,3	15,5	6	$d_1 + 3$	$d_1 + 18$	$13,5 \pm 1,2$	V	75 VS V
78	83	72	6,8	11	6	$d_1 + 3$	$d_1 + 18$	$9,0 \pm 1,2$	R	80 VA R
		72	6,8	11	6	$d_1 + 3$	$d_1 + 18$	$9,0 \pm 1,2$	V	80 VA V
		72	11,3	15,5	6	$d_1 + 3$	$d_1 + 18$	$13,5 \pm 1,2$	R	80 VS R
		72	11,3	15,5	6	$d_1 + 3$	$d_1 + 18$	$13,5 \pm 1,2$	V	80 VS V
83	88	76	6,8	11	6	$d_1 + 3$	$d_1 + 18$	$9,0 \pm 1,2$	R	85 VA R
		76	6,8	11	6	$d_1 + 3$	$d_1 + 18$	$9,0 \pm 1,2$	V	85 VA V
		76	11,3	15,5	6	$d_1 + 3$	$d_1 + 18$	$13,5 \pm 1,2$	R	85 VS R
		76	11,3	15,5	6	$d_1 + 3$	$d_1 + 18$	$13,5 \pm 1,2$	V	85 VS V

Select the larger V-ring when the dimension d_1 is on the boundary between two sizes of V-ring.

Dimensions		Seal inside diameter, free state d	Seal seat width b ₁	Nominal seal width b	Nominal seal height c	Clearance D ₁ max	Counterface D min	Seal fitted width B ₁	Lip code	Designation
Shaft diameter range d ₁ over	incl.									
mm										
88	93	81	6,8	11	6	d ₁ +3	d ₁ +18	9,0±1,2	R	90 VA R
		81	6,8	11	6	d ₁ +3	d ₁ +18	9,0±1,2	V	90 VA V
		81	11,3	15,5	6	d ₁ +3	d ₁ +18	13,5±1,2	R	90 VS R
		81	11,3	15,5	6	d ₁ +3	d ₁ +18	13,5±1,2	V	90 VS V
93	98	85	6,8	11	6	d ₁ +3	d ₁ +18	9,0±1,2	R	95 VA R
		85	6,8	11	6	d ₁ +3	d ₁ +18	9,0±1,2	V	95 VA V
		85	11,3	15,5	6	d ₁ +3	d ₁ +18	13,5±1,2	R	95 VS R
		85	11,3	15,5	6	d ₁ +3	d ₁ +18	13,5±1,2	V	95 VS V
98	105	90	6,8	11	6	d ₁ +3	d ₁ +18	9,0±1,2	R	100 VA R
		90	6,8	11	6	d ₁ +3	d ₁ +18	9,0±1,2	V	100 VA V
		90	11,3	15,5	6	d ₁ +3	d ₁ +18	13,5±1,2	R	100 VS R
		90	11,3	15,5	6	d ₁ +3	d ₁ +18	13,5±1,2	V	100 VS V
105	115	99	6	10,5	6,5	d ₁ +5	d ₁ +20	8,0±1,5	R	110 VL R
		99	6	10,5	6,5	d ₁ +5	d ₁ +20	8,0±1,5	V	110 VL V
		99	7,9	12,8	7	d ₁ +4	d ₁ +21	10,5±1,5	R	110 VA R
		99	7,9	12,8	7	d ₁ +4	d ₁ +21	10,5±1,5	V	110 VA V
		99	13,1	18	7	d ₁ +4	d ₁ +21	15,5±1,5	R	110 VS R
		99	13,1	18	7	d ₁ +4	d ₁ +21	15,5±1,5	V	110 VS V
115	125	108	6	10,5	6,5	d ₁ +5	d ₁ +20	8,0±1,5	R	120 VL R
		108	6	10,5	6,5	d ₁ +5	d ₁ +20	8,0±1,5	V	120 VL V
		108	7,9	12,8	7	d ₁ +4	d ₁ +21	10,5±1,5	R	120 VA R
		108	7,9	12,8	7	d ₁ +4	d ₁ +21	10,5±1,5	V	120 VA V
		108	13,1	18	7	d ₁ +4	d ₁ +21	15,5±1,5	R	120 VS R
		108	13,1	18	7	d ₁ +4	d ₁ +21	15,5±1,5	V	120 VS V
125	135	117	6	10,5	6,5	d ₁ +5	d ₁ +20	8,0±1,5	R	130 VL R
		117	6	10,5	6,5	d ₁ +5	d ₁ +20	8,0±1,5	V	130 VL V
		117	7,9	12,8	7	d ₁ +4	d ₁ +21	10,5±1,5	R	130 VA R
		117	7,9	12,8	7	d ₁ +4	d ₁ +21	10,5±1,5	V	130 VA V
		117	13,1	18	7	d ₁ +4	d ₁ +21	15,5±1,5	R	130 VS R
		117	13,1	18	7	d ₁ +4	d ₁ +21	15,5±1,5	V	130 VS V
135	145	126	6	10,5	6,5	d ₁ +5	d ₁ +20	8,0±1,5	R	140 VL R
		126	6	10,5	6,5	d ₁ +5	d ₁ +20	8,0±1,5	V	140 VL V
		126	7,9	12,8	7	d ₁ +4	d ₁ +21	10,5±1,5	R	140 VA R
		126	7,9	12,8	7	d ₁ +4	d ₁ +21	10,5±1,5	V	140 VA V
		126	13,1	18	7	d ₁ +4	d ₁ +21	15,5±1,5	R	140 VS R
		126	13,1	18	7	d ₁ +4	d ₁ +21	15,5±1,5	V	140 VS V
145	155	135	6	10,5	6,5	d ₁ +5	d ₁ +20	8,0±1,5	R	150 VL R
		135	6	10,5	6,5	d ₁ +5	d ₁ +20	8,0±1,5	V	150 VL V
		135	7,9	12,8	7	d ₁ +4	d ₁ +21	10,5±1,5	R	150 VA R
		135	7,9	12,8	7	d ₁ +4	d ₁ +21	10,5±1,5	V	150 VA V
		135	13,1	18	7	d ₁ +4	d ₁ +21	15,5±1,5	R	150 VS R
		135	13,1	18	7	d ₁ +4	d ₁ +21	15,5±1,5	V	150 VS V
155	165	144	6	10,5	6,5	d ₁ +5	d ₁ +20	8,0±1,5	R	160 VL R
		144	6	10,5	6,5	d ₁ +5	d ₁ +20	8,0±1,5	V	160 VL V
		144	9	14,5	8	d ₁ +4	d ₁ +24	12,0±1,8	R	160 VA R
		144	9	14,5	8	d ₁ +4	d ₁ +24	12,0±1,8	V	160 VA V
		144	15	20,5	8	d ₁ +4	d ₁ +24	18,0±1,8	R	160 VS R
		144	15	20,5	8	d ₁ +4	d ₁ +24	18,0±1,8	V	160 VS V
165	175	153	6	10,5	6,5	d ₁ +5	d ₁ +20	8,0±1,5	R	170 VL R
		153	6	10,5	6,5	d ₁ +5	d ₁ +20	8,0±1,5	V	170 VL V
		153	9	14,5	8	d ₁ +4	d ₁ +24	12,0±1,8	R	170 VA R
		153	9	14,5	8	d ₁ +4	d ₁ +24	12,0±1,8	V	170 VA V
		153	15	20,5	8	d ₁ +4	d ₁ +24	18,0±1,8	R	170 VS R
		153	15	20,5	8	d ₁ +4	d ₁ +24	18,0±1,8	V	170 VS V

7.2

V-ring seals – metric dimensions, globally valid outside North American market

d_1 175 – 375 mm

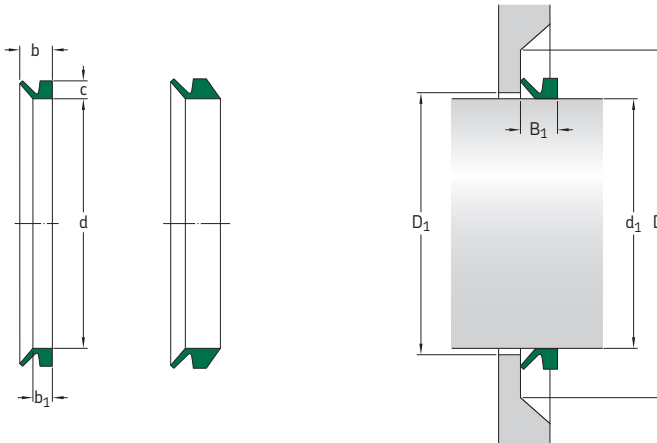

Dimensions		Seal inside diameter, free state d	Seal seat width b_1	Nominal seal width b	Nominal seal height c	Clearance D_1 max	Counterface D min	Seal fitted width B_1	Lip code	Designation
Shaft diameter range d_1 over	incl.									
mm										
175	185	162	6	10,5	6,5	$d_1 + 5$	$d_1 + 20$	$8,0 \pm 1,5$	R	180 VL R
		162	6	10,5	6,5	$d_1 + 5$	$d_1 + 20$	$8,0 \pm 1,5$	V	180 VL V
		162	9	14,5	8	$d_1 + 4$	$d_1 + 24$	$12,0 \pm 1,8$	R	180 VA R
		162	9	14,5	8	$d_1 + 4$	$d_1 + 24$	$12,0 \pm 1,8$	V	180 VA V
		162	15	20,5	8	$d_1 + 4$	$d_1 + 24$	$18,0 \pm 1,8$	R	180 VS R
		162	15	20,5	8	$d_1 + 4$	$d_1 + 24$	$18,0 \pm 1,8$	V	180 VS V
185	195	171	6	10,5	6,5	$d_1 + 5$	$d_1 + 20$	$8,0 \pm 1,5$	R	190 VL R
		171	6	10,5	6,5	$d_1 + 5$	$d_1 + 20$	$8,0 \pm 1,5$	V	190 VL V
		171	9	14,5	8	$d_1 + 4$	$d_1 + 24$	$12,0 \pm 1,8$	R	190 VA R
		171	9	14,5	8	$d_1 + 4$	$d_1 + 24$	$12,0 \pm 1,8$	V	190 VA V
		171	15	20,5	8	$d_1 + 4$	$d_1 + 24$	$18,0 \pm 1,8$	R	190 VS R
		171	15	20,5	8	$d_1 + 4$	$d_1 + 24$	$18,0 \pm 1,8$	V	190 VS V
195	210	180	9	14,5	8	$d_1 + 4$	$d_1 + 24$	$12,0 \pm 1,8$	R	199 VA R
		180	9	14,5	8	$d_1 + 4$	$d_1 + 24$	$12,0 \pm 1,8$	V	199 VA V
190	210	180	14,3	25	15	$d_1 + 10$	$d_1 + 45$	$20,0 \pm 4$	R	200 VA R
		180	14,3	25	15	$d_1 + 10$	$d_1 + 45$	$20,0 \pm 4$	V	200 VA V
195	210	180	15	20,5	8	$d_1 + 4$	$d_1 + 24$	$18,0 \pm 1,8$	R	199 VS R
		180	15	20,5	8	$d_1 + 4$	$d_1 + 24$	$18,0 \pm 1,8$	V	199 VS V
		182	6	10,5	6,5	$d_1 + 5$	$d_1 + 20$	$8,0 \pm 1,5$	R	200 VL R
		182	6	10,5	6,5	$d_1 + 5$	$d_1 + 20$	$8,0 \pm 1,5$	V	200 VL V
210	233	198	6	10,5	6,5	$d_1 + 5$	$d_1 + 20$	$8,0 \pm 1,5$	R	220 VL R
		198	6	10,5	6,5	$d_1 + 5$	$d_1 + 20$	$8,0 \pm 1,5$	V	220 VL V
210	235	198	14,3	25	15	$d_1 + 10$	$d_1 + 45$	$20,0 \pm 4$	R	220 VA R
		198	14,3	25	15	$d_1 + 10$	$d_1 + 45$	$20,0 \pm 4$	V	220 VA V
233	260	225	6	10,5	6,5	$d_1 + 5$	$d_1 + 20$	$8,0 \pm 1,5$	R	250 VL R
		225	6	10,5	6,5	$d_1 + 5$	$d_1 + 20$	$8,0 \pm 1,5$	V	250 VL V
235	265	225	14,3	25	15	$d_1 + 10$	$d_1 + 45$	$20,0 \pm 4$	R	250 VA R
		225	14,3	25	15	$d_1 + 10$	$d_1 + 45$	$20,0 \pm 4$	V	250 VA V
260	285	247	6	10,5	6,5	$d_1 + 5$	$d_1 + 20$	$8,0 \pm 1,5$	R	275 VL R
		247	6	10,5	6,5	$d_1 + 5$	$d_1 + 20$	$8,0 \pm 1,5$	V	275 VL V

Select the larger V-ring when the dimension d_1 is on the boundary between two sizes of V-ring.

Dimensions		Seal inside diameter, free state d	Seal seat width b ₁	Nominal seal width b	Nominal seal height c	Clearance D ₁ max	Counterface D min	Seal fitted width B ₁	Lip code	Designation
Shaft diameter range d ₁ over	incl.									
mm										
265	290	247	14,3	25	15	d ₁ +10	d ₁ +45	20,0±4	R	275 VA R
		247	14,3	25	15	d ₁ +10	d ₁ +45	20,0±4	V	275 VAV
285	310	270	6	10,5	6,5	d ₁ +5	d ₁ +20	8,0±1,5	R	300 VL R
		270	6	10,5	6,5	d ₁ +5	d ₁ +20	8,0±1,5	V	300 VLV
290	310	270	14,3	25	15	d ₁ +10	d ₁ +45	20,0±4	R	300 VA R
		270	14,3	25	15	d ₁ +10	d ₁ +45	20,0±4	V	300 VAV
310	335	292	6	10,5	6,5	d ₁ +5	d ₁ +20	8,0±1,5	R	325 VL R
		292	6	10,5	6,5	d ₁ +5	d ₁ +20	8,0±1,5	V	325 VLV
		292	14,3	25	15	d ₁ +10	d ₁ +45	20,0±4	R	325 VA R
		292	14,3	25	15	d ₁ +10	d ₁ +45	20,0±4	V	325 VAV
300	305	294	32,5	65	21	d ₁ +24	d ₁ +115	50±12	R	300 VRME R
		294	32,5	65	30	d ₁ +24	d ₁ +115	50±12	R	300 VE R
305	310	299	32,5	65	30	d ₁ +24	d ₁ +115	50±12	R	305 VE R
310	315	304	32,5	65	21	d ₁ +24	d ₁ +115	50±12	R	310 VRME R
		304	32,5	65	30	d ₁ +24	d ₁ +115	50±12	R	310 VE R
315	320	309	32,5	65	30	d ₁ +24	d ₁ +115	50±12	R	315 VE R
320	325	314	32,5	65	30	d ₁ +24	d ₁ +115	50±12	R	320 VE R
335	365	315	6	10,5	6,5	d ₁ +5	d ₁ +20	8,0±1,5	R	350 VL R
		315	6	10,5	6,5	d ₁ +5	d ₁ +20	8,0±1,5	V	350 VLV
		315	14,3	25	15	d ₁ +10	d ₁ +45	20,0±4	R	350 VA R
		315	14,3	25	15	d ₁ +10	d ₁ +45	20,0±4	V	350 VAV
325	330	319	32,5	65	21	d ₁ +24	d ₁ +115	50±12	R	325 VRME R
		319	32,5	65	30	d ₁ +24	d ₁ +115	50±12	R	325 VE R
330	335	323	32,5	65	30	d ₁ +24	d ₁ +115	50±12	R	330 VE R
335	340	328	32,5	65	30	d ₁ +24	d ₁ +115	50±12	R	335 VE R
340	345	333	32,5	65	21	d ₁ +24	d ₁ +115	50±12	R	340 VRME R
		333	32,5	65	30	d ₁ +24	d ₁ +115	50±12	R	340 VE R
365	385	337	6	10,5	6,5	d ₁ +5	d ₁ +20	8,0±1,5	R	375 VL R
		337	6	10,5	6,5	d ₁ +5	d ₁ +20	8,0±1,5	V	375 VLV
365	390	337	14,3	25	15	d ₁ +10	d ₁ +45	20,0±4	R	375 VA R
		337	14,3	25	15	d ₁ +10	d ₁ +45	20,0±4	V	375 VAV
345	350	338	32,5	65	30	d ₁ +24	d ₁ +115	50±12	R	345 VE R
350	355	343	32,5	65	21	d ₁ +24	d ₁ +115	50±12	R	350 VRME R
		343	32,5	65	30	d ₁ +24	d ₁ +115	50±12	R	350 VE R
355	360	347	32,5	65	21	d ₁ +24	d ₁ +115	50±12	R	355 VRME R
		347	32,5	65	30	d ₁ +24	d ₁ +115	50±12	R	355 VE R
360	365	352	32,5	65	30	d ₁ +24	d ₁ +115	50±12	R	360 VE R
365	370	357	32,5	65	30	d ₁ +24	d ₁ +115	50±12	R	365 VE R
385	410	360	6	10,5	6,5	d ₁ +5	d ₁ +20	8,0±1,5	R	400 VL R
		360	6	10,5	6,5	d ₁ +5	d ₁ +20	8,0±1,5	V	400 VLV
390	430	360	14,3	25	15	d ₁ +10	d ₁ +45	20,0±4	R	400 VA R
		360	14,3	25	15	d ₁ +10	d ₁ +45	20,0±4	V	400 VAV
370	375	362	32,5	65	21	d ₁ +24	d ₁ +115	50±12	R	370 VRME R
		362	32,5	65	30	d ₁ +24	d ₁ +115	50±12	R	370 VE R

7.2

V-ring seals – metric dimensions, globally valid outside North American market

d_1 375 – 550 mm

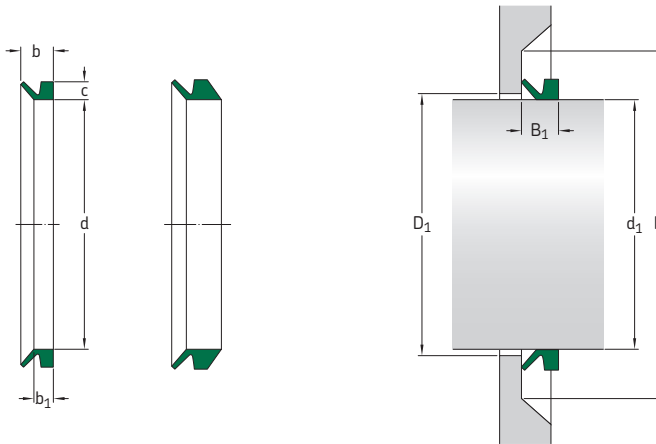

Dimensions		Seal inside diameter, free state d	Seal seat width b_1	Nominal seal width b	Nominal seal height c	Clearance D_1 max	Counterface D min	Seal fitted width B_1	Lip code	Designation
Shaft diameter range d_1 over	incl.									
mm										
375	380	367	32,5	65	21	$d_1 + 24$	$d_1 + 115$	50 ± 12	R	375 VRME R 375 VE R
		367	32,5	65	30	$d_1 + 24$	$d_1 + 115$	50 ± 12	R	
380	385	371	32,5	65	21	$d_1 + 24$	$d_1 + 115$	50 ± 12	R	380 VRME R 380 VE R
		371	32,5	65	30	$d_1 + 24$	$d_1 + 115$	50 ± 12	R	
385	390	376	32,5	65	30	$d_1 + 24$	$d_1 + 115$	50 ± 12	R	385 VE R
390	395	381	32,5	65	21	$d_1 + 24$	$d_1 + 115$	50 ± 12	R	390 VRME R 390 VE R
		381	32,5	65	30	$d_1 + 24$	$d_1 + 115$	50 ± 12	R	
410	440	382	6	10,5	6,5	$d_1 + 5$	$d_1 + 20$	$8,0 \pm 1,5$	R	425 VL R
		382	6	10,5	6,5	$d_1 + 5$	$d_1 + 20$	$8,0 \pm 1,5$	V	425 VLV
395	400	386	32,5	65	30	$d_1 + 24$	$d_1 + 115$	50 ± 12	R	395 VE R
400	405	391	32,5	65	21	$d_1 + 24$	$d_1 + 115$	50 ± 12	R	400 VRME R 400 VE R
		391	32,5	65	30	$d_1 + 24$	$d_1 + 115$	50 ± 12	R	
405	410	396	32,5	65	30	$d_1 + 24$	$d_1 + 115$	50 ± 12	R	405 VE R
410	415	401	32,5	65	21	$d_1 + 24$	$d_1 + 115$	50 ± 12	R	410 VRME R 410 VE R
		401	32,5	65	30	$d_1 + 24$	$d_1 + 115$	50 ± 12	R	
440	475	405	6	10,5	6,5	$d_1 + 5$	$d_1 + 20$	$8,0 \pm 1,5$	R	450 VL R
		405	6	10,5	6,5	$d_1 + 5$	$d_1 + 20$	$8,0 \pm 1,5$	V	450 VLV
430	480	405	14,3	25	15	$d_1 + 10$	$d_1 + 45$	$20,0 \pm 4$	R	450 VA R 450 VAV
		405	14,3	25	15	$d_1 + 10$	$d_1 + 45$	$20,0 \pm 4$	V	
415	420	405	32,5	65	30	$d_1 + 24$	$d_1 + 115$	50 ± 12	R	415 VE R
420	425	410	32,5	65	21	$d_1 + 24$	$d_1 + 115$	50 ± 12	R	420 VRME R 420 VE R
		410	32,5	65	30	$d_1 + 24$	$d_1 + 115$	50 ± 12	R	
425	430	415	32,5	65	30	$d_1 + 24$	$d_1 + 115$	50 ± 12	R	425 VE R
430	435	420	32,5	65	21	$d_1 + 24$	$d_1 + 115$	50 ± 12	R	430 VRME R 430 VE R
		420	32,5	65	30	$d_1 + 24$	$d_1 + 115$	50 ± 12	R	

Select the larger V-ring when the dimension d_1 is on the boundary between two sizes of V-ring.

Dimensions		Seal inside diameter, free state d	Seal seat width b ₁	Nominal seal width b	Nominal seal height c	Clearance D ₁ max	Counterface D min	Seal fitted width B ₁	Lip code	Designation
Shaft diameter range d ₁ over	incl.									
mm										
435	440	425	32,5	65	30	d ₁ + 24	d ₁ + 115	50 ± 12	R	435 VE R
440	445	429	32,5	65	30	d ₁ + 24	d ₁ + 115	50 ± 12	R	440 VE R
445	450	434	32,5	65	30	d ₁ + 24	d ₁ + 115	50 ± 12	R	445 VE R
450	455	439 439	32,5 67,5	65 100	30 13	d ₁ + 24 d ₁ + 24	d ₁ + 115 d ₁ + 115	50 ± 12 85 ± 12	R R	450 VE R 450 VRM R
455	460	444	32,5	65	30	d ₁ + 24	d ₁ + 115	50 ± 12	R	455 VE R
460	465	448 448	32,5 32,5	65 65	21 30	d ₁ + 24 d ₁ + 24	d ₁ + 115 d ₁ + 115	50 ± 12 50 ± 12	R R	460 VRME R 460 VE R
475	510	450 450	6 6	10,5 10,5	6,5 6,5	d ₁ + 5 d ₁ + 5	d ₁ + 20 d ₁ + 20	8,0 ± 1,5 8,0 ± 1,5	R V	500 VL R 500 VL V
480	530	450 450	14,3 14,3	25 25	15 15	d ₁ + 10 d ₁ + 10	d ₁ + 45 d ₁ + 45	20,0 ± 4 20,0 ± 4	R V	500 VA R 500 VAV
465	470	453	32,5	65	30	d ₁ + 24	d ₁ + 115	50 ± 12	R	465 VE R
470	475	458	32,5	65	30	d ₁ + 24	d ₁ + 115	50 ± 12	R	470 VE R
475	480	463 463	32,5 32,5	65 65	21 30	d ₁ + 24 d ₁ + 24	d ₁ + 115 d ₁ + 115	50 ± 12 50 ± 12	R R	475 VRME R 475 VE R
480	485	468	32,5	65	30	d ₁ + 24	d ₁ + 115	50 ± 12	R	480 VE R
510	540	472 472	6 6	10,5 10,5	6,5 6,5	d ₁ + 5 d ₁ + 5	d ₁ + 20 d ₁ + 20	8,0 ± 1,5 8,0 ± 1,5	R V	525 VL R 525 VL V
485	490	473	32,5	65	30	d ₁ + 24	d ₁ + 115	50 ± 12	R	485 VE R
490	495	478	32,5	65	30	d ₁ + 24	d ₁ + 115	50 ± 12	R	490 VE R
495	500	483 483	32,5 32,5	65 65	21 30	d ₁ + 24 d ₁ + 24	d ₁ + 115 d ₁ + 115	50 ± 12 50 ± 12	R R	495 VRME R 495 VE R
500	505	488 488	32,5 67,5	65 100	30 13	d ₁ + 24 d ₁ + 24	d ₁ + 115 d ₁ + 115	50 ± 12 85 ± 12	R R	500 VE R 500 VRM R
505	510	493	32,5	65	30	d ₁ + 24	d ₁ + 115	50 ± 12	R	505 VE R
540	575	495 495	6 6	10,5 10,5	6,5 6,5	d ₁ + 5 d ₁ + 5	d ₁ + 20 d ₁ + 20	8,0 ± 1,5 8,0 ± 1,5	R V	550 VL R 550 VL V
530	580	495 495	14,3 14,3	25 25	15 15	d ₁ + 10 d ₁ + 10	d ₁ + 45 d ₁ + 45	20,0 ± 4 20,0 ± 4	R V	550 VA R 550 VAV
510	515	497	32,5	65	30	d ₁ + 24	d ₁ + 115	50 ± 12	R	510 VE R
515	520	502	32,5	65	30	d ₁ + 24	d ₁ + 115	50 ± 12	R	515 VE R
520	525	507	32,5	65	30	d ₁ + 24	d ₁ + 115	50 ± 12	R	520 VE R
525	530	512 512	32,5 32,5	65 65	21 30	d ₁ + 24 d ₁ + 24	d ₁ + 115 d ₁ + 115	50 ± 12 50 ± 12	R R	525 VRME R 525 VE R
530	535	517	32,5	65	30	d ₁ + 24	d ₁ + 115	50 ± 12	R	530 VE R
535	540	521	32,5	65	30	d ₁ + 24	d ₁ + 115	50 ± 12	R	535 VE R
540	545	526	32,5	65	30	d ₁ + 24	d ₁ + 115	50 ± 12	R	540 VE R
545	550	531	32,5	65	30	d ₁ + 24	d ₁ + 115	50 ± 12	R	545 VE R

7.2

V-ring seals – metric dimensions, globally valid outside North American market
d₁ 550 – 792 mm

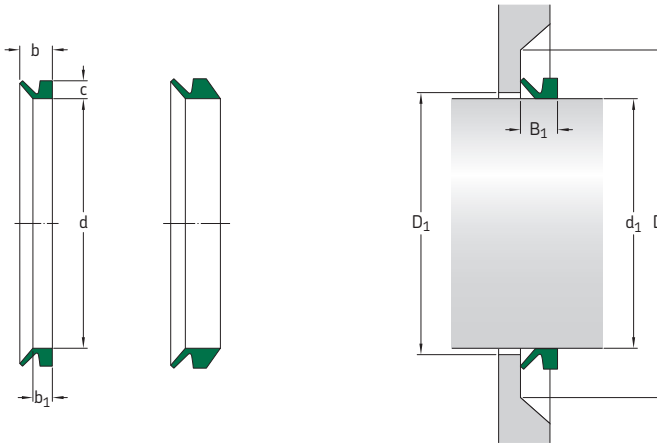

Dimensions		Seal inside diameter, free state d	Seal seat width b ₁	Nominal seal width b	Nominal seal height c	Clearance D ₁ max	Counterface D min	Seal fitted width B ₁	Lip code	Designation
Shaft diameter range d ₁ over	incl.									
mm										
550	555	536 536	32,5 67,5	65 100	30 13	d ₁ + 24 d ₁ + 24	d ₁ + 115 d ₁ + 115	50 ± 12 85 ± 12	R R	550 VE R 550 VRM R
575	625	540 540	6 6	10,5 10,5	6,5 6,5	d ₁ + 5 d ₁ + 5	d ₁ + 20 d ₁ + 20	8,0 ± 1,5 8,0 ± 1,5	R V	600 VL R 600 VL V
580	630	540 540	14,3 14,3	25 25	15 15	d ₁ + 10 d ₁ + 10	d ₁ + 45 d ₁ + 45	20,0 ± 4 20,0 ± 4	R V	600 VA R 600 VA V
555	560	541	32,5	65	30	d ₁ + 24	d ₁ + 115	50 ± 12	R	555 VE R
560	565	546	32,5	65	30	d ₁ + 24	d ₁ + 115	50 ± 12	R	560 VE R
565	570	550	32,5	65	30	d ₁ + 24	d ₁ + 115	50 ± 12	R	565 VE R
570	575	555	32,5	65	30	d ₁ + 24	d ₁ + 115	50 ± 12	R	570 VE R
575	580	560	32,5	65	30	d ₁ + 24	d ₁ + 115	50 ± 12	R	575 VE R
580	585	565	32,5	65	30	d ₁ + 24	d ₁ + 115	50 ± 12	R	580 VE R
585	590	570	32,5	65	30	d ₁ + 24	d ₁ + 115	50 ± 12	R	585 VE R
590	600	575	32,5	65	30	d ₁ + 24	d ₁ + 115	50 ± 12	R	590 VE R
600	610	582 582	32,5 67,5	65 100	30 13	d ₁ + 24 d ₁ + 24	d ₁ + 115 d ₁ + 115	50 ± 12 85 ± 12	R R	600 VE R 600 VRM R
610	620	592	32,5	65	30	d ₁ + 24	d ₁ + 115	50 ± 12	R	610 VE R
615	675	600 600	6 6	10,5 10,5	6,5 6,5	d ₁ + 5 d ₁ + 5	d ₁ + 20 d ₁ + 20	8,0 ± 1,5 8,0 ± 1,5	R V	650 VL R 650 VL V
630	665	600 600	14,3 14,3	25 25	15 15	d ₁ + 10 d ₁ + 10	d ₁ + 45 d ₁ + 45	20,0 ± 4 20,0 ± 4	R V	650 VA R 650 VA V
620	630	602	32,5	65	30	d ₁ + 24	d ₁ + 115	50 ± 12	R	620 VE R
630	640	612	32,5	65	30	d ₁ + 24	d ₁ + 115	50 ± 12	R	630 VE R

Select the larger V-ring when the dimension d₁ is on the boundary between two sizes of V-ring.

Dimensions		Seal inside diameter, free state d	Seal seat width b ₁	Nominal seal width b	Nominal seal height c	Clearance D ₁ max	Counterface D min	Seal fitted width B ₁	Lip code	Designation
Shaft diameter range d ₁ over	incl.									
mm										
640	650	621	32,5	65	30	d ₁ + 24	d ₁ + 115	50 ± 12	R	640 VE R
675	710	630 630	6 6	10,5 10,5	6,5 6,5	d ₁ + 5 d ₁ + 5	d ₁ + 20 d ₁ + 20	8,0 ± 1,5 8,0 ± 1,5	R V	700 VL R 700 VL V
665	705	630 630	14,3 14,3	25 25	15 15	d ₁ + 10 d ₁ + 10	d ₁ + 45 d ₁ + 45	20,0 ± 4 20,0 ± 4	R V	700 VA R 700 VA V
650	660	631 631 631	32,5 32,5 67,5	65 65 100	21 30 13	d ₁ + 24 d ₁ + 24 d ₁ + 24	d ₁ + 115 d ₁ + 115 d ₁ + 115	50 ± 12 50 ± 12 85 ± 12	R R R	650 VRME R 650 VE R 650 VRM R
660	670	640 640	32,5 32,5	65 65	21 30	d ₁ + 24 d ₁ + 24	d ₁ + 115 d ₁ + 115	50 ± 12 50 ± 12	R R	660 VRME R 660 VE R
670	680	650 650	32,5 32,5	65 65	21 30	d ₁ + 24 d ₁ + 24	d ₁ + 115 d ₁ + 115	50 ± 12 50 ± 12	R R	670 VRME R 670 VE R
680	690	660 660	32,5 32,5	65 65	21 30	d ₁ + 24 d ₁ + 24	d ₁ + 115 d ₁ + 115	50 ± 12 50 ± 12	R R	680 VRME R 680 VE R
710	740	670 670	6 6	10,5 10,5	6,5 6,5	d ₁ + 5 d ₁ + 5	d ₁ + 20 d ₁ + 20	8,0 ± 1,5 8,0 ± 1,5	R V	725 VL R 725 VL V
705	745	670 670	14,3 14,3	25 25	15 15	d ₁ + 10 d ₁ + 10	d ₁ + 45 d ₁ + 45	20,0 ± 4 20,0 ± 4	R V	725 VA R 725 VA V
690	700	670 670	32,5 32,5	65 65	21 30	d ₁ + 24 d ₁ + 24	d ₁ + 115 d ₁ + 115	50 ± 12 50 ± 12	R R	690 VRME R 690 VE R
700	710	680 680	32,5 67,5	65 100	30 13	d ₁ + 24 d ₁ + 24	d ₁ + 115 d ₁ + 115	50 ± 12 85 ± 12	R R	700 VE R 700 VRM R
710	720	689	32,5	65	30	d ₁ + 24	d ₁ + 115	50 ± 12	R	710 VE R
720	730	699	32,5	65	30	d ₁ + 24	d ₁ + 115	50 ± 12	R	720 VE R
740	775	705 705	6 6	10,5 10,5	6,5 6,5	d ₁ + 5 d ₁ + 5	d ₁ + 20 d ₁ + 20	8,0 ± 1,5 8,0 ± 1,5	R V	750 VL R 750 VL V
745	785	705 705	14,3 14,3	25 25	15 15	d ₁ + 10 d ₁ + 10	d ₁ + 45 d ₁ + 45	20,0 ± 4 20,0 ± 4	R V	750 VA R 750 VA V
730	740	709	32,5	65	30	d ₁ + 24	d ₁ + 115	50 ± 12	R	730 VE R
740	750	718	32,5	65	30	d ₁ + 24	d ₁ + 115	50 ± 12	R	740 VE R
750	758	728 728 728	32,5 32,5 67,5	65 65 100	21 30 13	d ₁ + 24 d ₁ + 24 d ₁ + 24	d ₁ + 115 d ₁ + 115 d ₁ + 115	50 ± 12 50 ± 12 85 ± 12	R R R	750 VRME R 750 VE R 750 VRM R
758	766	735 735	32,5 32,5	65 65	21 30	d ₁ + 24 d ₁ + 24	d ₁ + 115 d ₁ + 115	50 ± 12 50 ± 12	R R	760 VRME R 760 VE R
766	774	743	32,5	65	30	d ₁ + 24	d ₁ + 115	50 ± 12	R	770 VE R
775	825	745 745	6 6	10,5 10,5	6,5 6,5	d ₁ + 5 d ₁ + 5	d ₁ + 20 d ₁ + 20	8,0 ± 1,5 8,0 ± 1,5	R V	800 VL R 800 VL V
785	830	745 745	14,3 14,3	25 25	15 15	d ₁ + 10 d ₁ + 10	d ₁ + 45 d ₁ + 45	20,0 ± 4 20,0 ± 4	R V	800 VA R 800 VA V
774	783	751	32,5	65	30	d ₁ + 24	d ₁ + 115	50 ± 12	R	780 VE R
783	792	759 759	32,5 32,5	65 65	21 30	d ₁ + 24 d ₁ + 24	d ₁ + 115 d ₁ + 115	50 ± 12 50 ± 12	R R	790 VRME R 790 VE R

7.2

V-ring seals – metric dimensions, globally valid outside North American market
d₁ 792 – 1 165 mm

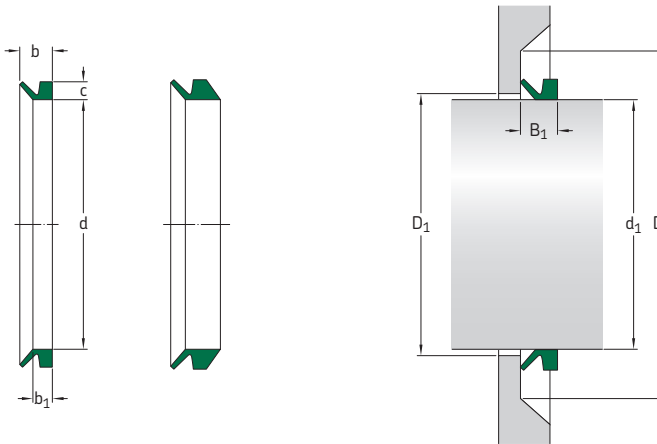

Dimensions		Seal inside diameter, free state d	Seal seat width b ₁	Nominal seal width b	Nominal seal height c	Clearance D ₁ max	Counterface D min	Seal fitted width B ₁	Lip code	Designation
Shaft diameter range d ₁ over	incl.									
mm										
792	801	768	32,5	65	21	d ₁ + 24	d ₁ + 115	50 ± 12	R	800 VRME R
		768	32,5	65	30	d ₁ + 24	d ₁ + 115	50 ± 12	R	800 VE R
		768	67,5	100	13	d ₁ + 24	d ₁ + 115	85 ± 12	R	800 VRM R
801	810	777	32,5	65	30	d ₁ + 24	d ₁ + 115	50 ± 12	R	810 VE R
825	875	785	6	10,5	6,5	d ₁ + 5	d ₁ + 20	8,0 ± 1,5	R	850 VL R
		785	6	10,5	6,5	d ₁ + 5	d ₁ + 20	8,0 ± 1,5	V	850 VL V
830	875	785	14,3	25	15	d ₁ + 10	d ₁ + 45	20,0 ± 4	R	850 VA R
		785	14,3	25	15	d ₁ + 10	d ₁ + 45	20,0 ± 4	V	850 VAV
810	821	786	32,5	65	30	d ₁ + 24	d ₁ + 115	50 ± 12	R	820 VE R
821	831	796	32,5	65	21	d ₁ + 24	d ₁ + 115	50 ± 12	R	830 VRME R
		796	32,5	65	30	d ₁ + 24	d ₁ + 115	50 ± 12	R	830 VE R
831	841	805	32,5	65	30	d ₁ + 24	d ₁ + 115	50 ± 12	R	840 VE R
841	851	814	32,5	65	30	d ₁ + 24	d ₁ + 115	50 ± 12	R	850 VE R
		814	67,5	100	13	d ₁ + 24	d ₁ + 115	85 ± 12	R	850 VRM R
851	861	824	32,5	65	30	d ₁ + 24	d ₁ + 115	50 ± 12	R	860 VE R
875	925	825	6	10,5	6,5	d ₁ + 5	d ₁ + 20	8,0 ± 1,5	R	900 VL R
		825	6	10,5	6,5	d ₁ + 5	d ₁ + 20	8,0 ± 1,5	V	900 VL V
875	920	825	14,3	25	15	d ₁ + 10	d ₁ + 45	20,0 ± 4	R	900 VA R
		825	14,3	25	15	d ₁ + 10	d ₁ + 45	20,0 ± 4	V	900 VAV
861	871	833	32,5	65	30	d ₁ + 24	d ₁ + 115	50 ± 12	R	870 VE R
		833	32,5	65	30	d ₁ + 24	d ₁ + 115	50 ± 12	R	870 VE R
871	882	843	32,5	65	21	d ₁ + 24	d ₁ + 115	50 ± 12	R	880 VRME R
		843	32,5	65	30	d ₁ + 24	d ₁ + 115	50 ± 12	R	880 VE R
882	892	853	32,5	65	30	d ₁ + 24	d ₁ + 115	50 ± 12	R	890 VE R
925	975	865	6	10,5	6,5	d ₁ + 5	d ₁ + 20	8,0 ± 1,5	R	950 VL R
		865	6	10,5	6,5	d ₁ + 5	d ₁ + 20	8,0 ± 1,5	V	950 VL V

Select the larger V-ring when the dimension d₁ is on the boundary between two sizes of V-ring.

Dimensions		Seal inside diameter, free state d	Seal seat width b ₁	Nominal seal width b	Nominal seal height c	Clearance D ₁ max	Counterface D min	Seal fitted width B ₁	Lip code	Designation
Shaft diameter range d ₁ over	incl.									
mm										
920	965	865 865	14,3 14,3	25 25	15 15	d ₁ +10 d ₁ +10	d ₁ +45 d ₁ +45	20,0±4 20,0±4	R V	950 VA R 950 VAV
892	912	871 871 871	32,5 32,5 67,5	65 65 100	21 30 13	d ₁ +24 d ₁ +24 d ₁ +24	d ₁ +115 d ₁ +115 d ₁ +115	50±12 50±12 85±12	R R R	900 VRME R 900 VE R 900 VRM R
912	922	880	32,5	65	30	d ₁ +24	d ₁ +115	50±12	R	920 VE R
922	933	890	32,5	65	30	d ₁ +24	d ₁ +115	50±12	R	930 VE R
933	944	900	32,5	65	30	d ₁ +24	d ₁ +115	50±12	R	940 VE R
975	1025	910 910	6 6	10,5 10,5	6,5 6,5	d ₁ +5 d ₁ +5	d ₁ +20 d ₁ +20	8,0±1,5 8,0±1,5	R V	1000 VL R 1000 VL V
944	955	911 911	32,5 67,5	65 100	30 13	d ₁ +24 d ₁ +24	d ₁ +115 d ₁ +115	50±12 85±12	R R	950 VE R 950 VRM R
955	966	921	32,5	65	30	d ₁ +24	d ₁ +115	50±12	R	960 VE R
966	977	932	32,5	65	30	d ₁ +24	d ₁ +115	50±12	R	970 VE R
977	988	942 942	32,5 32,5	65 65	21 30	d ₁ +24 d ₁ +24	d ₁ +115 d ₁ +115	50±12 50±12	R R	980 VRME R 980 VE R
988	999	953	32,5	65	30	d ₁ +24	d ₁ +115	50±12	R	990 VE R
1025	1075	955 955	6 6	10,5 10,5	6,5 6,5	d ₁ +5 d ₁ +5	d ₁ +20 d ₁ +20	8,0±1,5 8,0±1,5	R V	1050 VL R 1050 VL V
1015	1065	955	14,3	25	15	d ₁ +10	d ₁ +45	20,0±4	R	1050 VA R
999	1010	963 963	32,5 67,5	65 100	30 13	d ₁ +24 d ₁ +24	d ₁ +115 d ₁ +115	50±12 85±12	R R	1000 VE R 1000 VRM R
1010	1025	973	32,5	65	30	d ₁ +24	d ₁ +115	50±12	R	1020 VE R
1025	1045	990 990	32,5 32,5	65 65	21 30	d ₁ +24 d ₁ +24	d ₁ +115 d ₁ +115	50±12 50±12	R R	1040 VRME R 1040 VE R
1075	1125	1000 1000	6 6	10,5 10,5	6,5 6,5	d ₁ +5 d ₁ +5	d ₁ +20 d ₁ +20	8,0±1,5 8,0±1,5	R V	1100 VL R 1100 VL V
1065	1115	1000	14,3	25	15	d ₁ +10	d ₁ +45	20,0±4	R	1100 VA R
1045	1065	1008	32,5	65	30	d ₁ +24	d ₁ +115	50±12	R	1060 VE R
1065	1085	1027	32,5	65	30	d ₁ +24	d ₁ +115	50±12	R	1080 VE R
1125	1175	1045 1045	6 6	10,5 10,5	6,5 6,5	d ₁ +5 d ₁ +5	d ₁ +20 d ₁ +20	8,0±1,5 8,0±1,5	R V	1150 VL R 1150 VL V
1115	1165	1045	14,3	25	15	d ₁ +10	d ₁ +45	20,0±4	R	1150 VA R
1085	1105	1045 1045	32,5 67,5	65 100	30 13	d ₁ +24 d ₁ +24	d ₁ +115 d ₁ +115	50±12 85±12	R R	1100 VE R 1100 VRM R
1105	1125	1065	32,5	65	30	d ₁ +24	d ₁ +115	50±12	R	1120 VE R
1125	1145	1084	32,5	65	30	d ₁ +24	d ₁ +115	50±12	R	1140 VE R
1175	1225	1090	6	10,5	6,5	d ₁ +5	d ₁ +20	8,0±1,5	R	1200 VL R
1165	1215	1090	14,3	25	15	d ₁ +10	d ₁ +45	20,0±4	R	1200 VA R
1145	1165	1103	32,5	65	30	d ₁ +24	d ₁ +115	50±12	R	1160 VE R

7.2

V-ring seals – metric dimensions, globally valid outside North American market
d₁ 1 165 – 1 775 mm

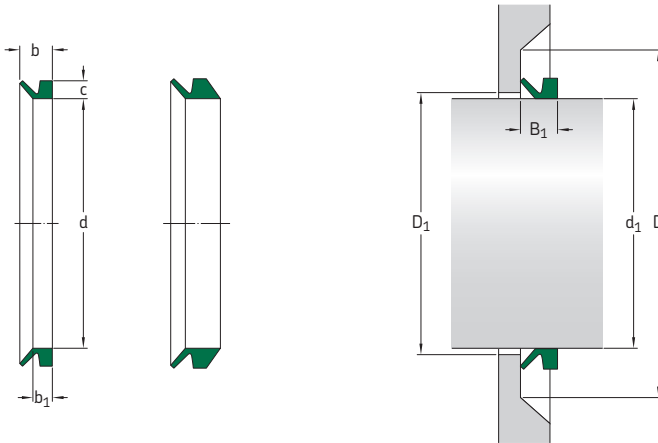

Dimensions		Seal inside diameter, free state d	Seal seat width b ₁	Nominal seal width b	Nominal seal height c	Clearance D ₁ max	Counterface D min	Seal fitted width B ₁	Lip code	Designation
Shaft diameter range d ₁ over	incl.									
mm										
1165	1185	1121	32,5	65	30	d ₁ + 24	d ₁ + 115	50 ± 12	R	1180 VE R
1225	1275	1135	6	10,5	6,5	d ₁ + 5	d ₁ + 20	8,0 ± 1,5	R	1250 VL R
		1135	6	10,5	6,5	d ₁ + 5	d ₁ + 20	8,0 ± 1,5	V	1250 VL V
1215	1270	1135	14,3	25	15	d ₁ + 10	d ₁ + 45	20,0 ± 4	R	1250 VA R
1185	1205	1139	32,5	65	21	d ₁ + 24	d ₁ + 115	50 ± 12	R	1200 VRME R
		1139	32,5	65	30	d ₁ + 24	d ₁ + 115	50 ± 12	R	1200 VE R
		1139	67,5	100	13	d ₁ + 24	d ₁ + 115	85 ± 12	R	1200 VRM R
1205	1225	1157	32,5	65	30	d ₁ + 24	d ₁ + 115	50 ± 12	R	1220 VE R
1225	1245	1176	32,5	65	30	d ₁ + 24	d ₁ + 115	50 ± 12	R	1240 VE R
1275	1325	1180	6	10,5	6,5	d ₁ + 5	d ₁ + 20	8,0 ± 1,5	R	1300 VL R
		1180	6	10,5	6,5	d ₁ + 5	d ₁ + 20	8,0 ± 1,5	V	1300 VL V
1270	1320	1180	14,3	25	15	d ₁ + 10	d ₁ + 45	20,0 ± 4	R	1300 VA R
1245	1270	1195	32,5	65	30	d ₁ + 24	d ₁ + 115	50 ± 12	R	1260 VE R
1270	1295	1218	32,5	65	30	d ₁ + 24	d ₁ + 115	50 ± 12	R	1280 VE R
1325	1375	1225	6	10,5	6,5	d ₁ + 5	d ₁ + 20	8,0 ± 1,5	R	1350 VL R
		1225	6	10,5	6,5	d ₁ + 5	d ₁ + 20	8,0 ± 1,5	V	1350 VL V
1320	1370	1225	14,3	25	15	d ₁ + 10	d ₁ + 45	20,0 ± 4	R	1350 VA R
1295	1315	1240	32,5	65	30	d ₁ + 24	d ₁ + 115	50 ± 12	R	1300 VE R
		1240	67,5	100	13	d ₁ + 24	d ₁ + 115	85 ± 12	R	1300 VRM R
1315	1340	1259	32,5	65	30	d ₁ + 24	d ₁ + 115	50 ± 12	R	1325 VE R
1375	1425	1270	6	10,5	6,5	d ₁ + 5	d ₁ + 20	8,0 ± 1,5	R	1400 VL R
		1270	6	10,5	6,5	d ₁ + 5	d ₁ + 20	8,0 ± 1,5	V	1400 VL V
1370	1420	1270	14,3	25	15	d ₁ + 10	d ₁ + 45	20,0 ± 4	R	1400 VA R

Select the larger V-ring when the dimension d₁ is on the boundary between two sizes of V-ring.

Dimensions		Seal inside diameter, free state d	Seal seat width b ₁	Nominal seal width b	Nominal seal height c	Clearance D ₁ max	Counterface D min	Seal fitted width B ₁	Lip code	Designation
Shaft diameter range d ₁ over	incl.									
mm										
1340	1365	1281	32,5	65	30	d ₁ +24	d ₁ +115	50±12	R	1350 VE R
		1281	67,5	100	13	d ₁ +24	d ₁ +115	85±12	R	1350 VRM R
1365	1390	1305	32,5	65	30	d ₁ +24	d ₁ +115	50±12	R	1375 VE R
1425	1475	1315	6	10,5	6,5	d ₁ +5	d ₁ +20	8,0±1,5	R	1450 VL R
		1315	6	10,5	6,5	d ₁ +5	d ₁ +20	8,0±1,5	V	1450 VL V
1420	1470	1315	14,3	25	15	d ₁ +10	d ₁ +45	20,0±4	R	1450 VA R
1390	1415	1328	32,5	65	30	d ₁ +24	d ₁ +115	50±12	R	1400 VE R
		1328	67,5	100	13	d ₁ +24	d ₁ +115	85±12	R	1400 VRM R
1415	1440	1350	32,5	65	21	d ₁ +24	d ₁ +115	50±12	R	1425 VRME R
		1350	32,5	65	30	d ₁ +24	d ₁ +115	50±12	R	1425 VE R
1475	1525	1360	6	10,5	6,5	d ₁ +5	d ₁ +20	8,0±1,5	R	1500 VL R
		1360	6	10,5	6,5	d ₁ +5	d ₁ +20	8,0±1,5	V	1500 VL V
1470	1520	1360	14,3	25	15	d ₁ +10	d ₁ +45	20,0±4	R	1500 VA R
1440	1465	1374	32,5	65	21	d ₁ +24	d ₁ +115	50±12	R	1450 VRME R
		1374	32,5	65	30	d ₁ +24	d ₁ +115	50±12	R	1450 VE R
		1374	67,5	100	13	d ₁ +24	d ₁ +115	85±12	R	1450 VRM R
1465	1490	1397	32,5	65	30	d ₁ +24	d ₁ +115	50±12	R	1475 VE R
1525	1575	1405	6	10,5	6,5	d ₁ +5	d ₁ +20	8,0±1,5	R	1550 VL R
		1405	6	10,5	6,5	d ₁ +5	d ₁ +20	8,0±1,5	V	1550 VL V
1520	1570	1405	14,3	25	15	d ₁ +10	d ₁ +45	20,0±4	R	1550 VA R
1490	1515	1419	32,5	65	21	d ₁ +24	d ₁ +115	50±12	R	1500 VRME R
		1419	32,5	65	30	d ₁ +24	d ₁ +115	50±12	R	1500 VE R
		1419	67,5	100	13	d ₁ +24	d ₁ +115	85±12	R	1500 VRM R
1515	1540	1443	32,5	65	30	d ₁ +24	d ₁ +115	50±12	R	1525 VE R
1575	1625	1450	6	10,5	6,5	d ₁ +5	d ₁ +20	8,0±1,5	R	1600 VL R
		1450	6	10,5	6,5	d ₁ +5	d ₁ +20	8,0±1,5	V	1600 VL V
1570	1620	1450	14,3	25	15	d ₁ +10	d ₁ +45	20,0±4	R	1600 VA R
1540	1570	1467	32,5	65	21	d ₁ +24	d ₁ +115	50±12	R	1550 VRME R
		1467	32,5	65	30	d ₁ +24	d ₁ +115	50±12	R	1550 VE R
		1467	67,5	100	13	d ₁ +24	d ₁ +115	85±12	R	1550 VRM R
1625	1675	1495	6	10,5	6,5	d ₁ +5	d ₁ +20	8,0±1,5	R	1650 VL R
		1495	6	10,5	6,5	d ₁ +5	d ₁ +20	8,0±1,5	V	1650 VL V
1620	1670	1495	14,3	25	15	d ₁ +10	d ₁ +45	20,0±4	R	1650 VA R
1570	1600	1495	32,5	65	30	d ₁ +24	d ₁ +115	50±12	R	1575 VE R
1600	1640	1524	32,5	65	30	d ₁ +24	d ₁ +115	50±12	R	1600 VE R
		1524	67,5	100	13	d ₁ +24	d ₁ +115	85±12	R	1600 VRM R
1675	1725	1540	6	10,5	6,5	d ₁ +5	d ₁ +20	8,0±1,5	R	1700 VL R
		1540	6	10,5	6,5	d ₁ +5	d ₁ +20	8,0±1,5	V	1700 VL V
1670	1720	1540	14,3	25	15	d ₁ +10	d ₁ +45	20,0±4	R	1700 VA R
1640	1680	1559	32,5	65	30	d ₁ +24	d ₁ +115	50±12	R	1650 VE R
		1559	67,5	100	13	d ₁ +24	d ₁ +115	85±12	R	1650 VRM R
1725	1775	1585	6	10,5	6,5	d ₁ +5	d ₁ +20	8,0±1,5	R	1750 VL R
		1585	6	10,5	6,5	d ₁ +5	d ₁ +20	8,0±1,5	V	1750 VL V

7.2

V-ring seals – metric dimensions, globally valid outside North American market

d_1 1 720 – 2 010 mm

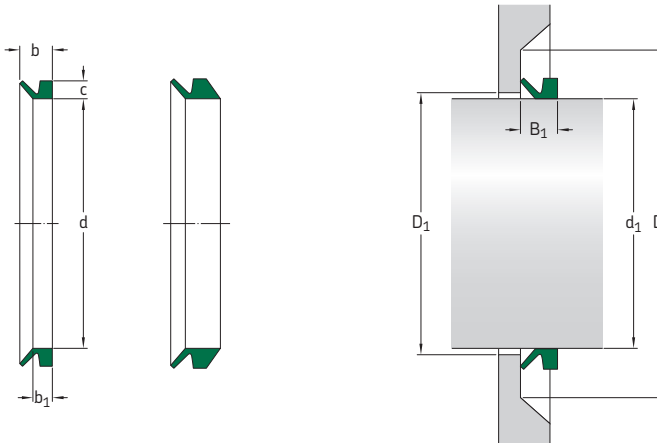

Dimensions		Seal inside diameter, free state d	Seal seat width b_1	Nominal seal width b	Nominal seal height c	Clearance D_1 max	Counterface D min	Seal fitted width B_1	Lip code	Designation
Shaft diameter range d_1 over	incl.									
mm										
1 720	1 770	1 585	14,3	25	15	$d_1 + 10$	$d_1 + 45$	$20,0 \pm 4$	R	1750 VA R
1 680	1 720	1 596	32,5	65	21	$d_1 + 24$	$d_1 + 115$	50 ± 12	R	1700 VRME R
		1 596	32,5	65	30	$d_1 + 24$	$d_1 + 115$	50 ± 12	R	1700 VE R
		1 596	67,5	100	13	$d_1 + 24$	$d_1 + 115$	85 ± 12	R	1700 VRM R
1 775	1 825	1 630	6	10,5	6,5	$d_1 + 5$	$d_1 + 20$	$8,0 \pm 1,5$	R	1800 VL R
		1 630	6	10,5	6,5	$d_1 + 5$	$d_1 + 20$	$8,0 \pm 1,5$	V	1800 VL V
1 770	1 820	1 630	14,3	25	15	$d_1 + 10$	$d_1 + 45$	$20,0 \pm 4$	R	1800 VA R
1 720	1 765	1 632	32,5	65	21	$d_1 + 24$	$d_1 + 115$	50 ± 12	R	1750 VRME R
		1 632	32,5	65	30	$d_1 + 24$	$d_1 + 115$	50 ± 12	R	1750 VE R
		1 632	67,5	100	13	$d_1 + 24$	$d_1 + 115$	85 ± 12	R	1750 VRM R
1 765	1 810	1 671	32,5	65	30	$d_1 + 24$	$d_1 + 115$	50 ± 12	R	1800 VE R
		1 671	67,5	100	13	$d_1 + 24$	$d_1 + 115$	85 ± 12	R	1800 VRM R
1 825	1 875	1 675	6	10,5	6,5	$d_1 + 5$	$d_1 + 20$	$8,0 \pm 1,5$	R	1850 VL R
		1 675	6	10,5	6,5	$d_1 + 5$	$d_1 + 20$	$8,0 \pm 1,5$	V	1850 VL V
1 820	1 870	1 675	14,3	25	15	$d_1 + 10$	$d_1 + 45$	$20,0 \pm 4$	R	1850 VA R
1 810	1 855	1 714	32,5	65	21	$d_1 + 24$	$d_1 + 115$	50 ± 12	R	1800 VRME R
		1 714	32,5	65	30	$d_1 + 24$	$d_1 + 115$	50 ± 12	R	1850 VE R
		1 714	67,5	100	13	$d_1 + 24$	$d_1 + 115$	85 ± 12	R	1850 VRM R
1 875	1 925	1 720	6	10,5	6,5	$d_1 + 5$	$d_1 + 20$	$8,0 \pm 1,5$	R	1900 VL R
		1 720	6	10,5	6,5	$d_1 + 5$	$d_1 + 20$	$8,0 \pm 1,5$	V	1900 VL V
1 870	1 920	1 720	14,3	25	15	$d_1 + 10$	$d_1 + 45$	$20,0 \pm 4$	R	1900 VA R
1 855	1 905	1 753	32,5	65	21	$d_1 + 24$	$d_1 + 115$	50 ± 12	R	1900 VRME R
		1 753	32,5	65	30	$d_1 + 24$	$d_1 + 115$	50 ± 12	R	1900 VE R
		1 753	67,5	100	13	$d_1 + 24$	$d_1 + 115$	85 ± 12	R	1900 VRM R
1 925	1 975	1 765	6	10,5	6,5	$d_1 + 5$	$d_1 + 20$	$8,0 \pm 1,5$	R	1950 VL R
		1 765	6	10,5	6,5	$d_1 + 5$	$d_1 + 20$	$8,0 \pm 1,5$	V	1950 VL V

Select the larger V-ring when the dimension d_1 is on the boundary between two sizes of V-ring.

Dimensions		Seal inside diameter, free state d	Seal seat width b ₁	Nominal seal width b	Nominal seal height c	Clearance D ₁ max	Counterface D min	Seal fitted width B ₁	Lip code	Designation
Shaft diameter range d ₁ over	incl.									
mm										
1 920	1 970	1 765	14,3	25	15	d ₁ +10	d ₁ +45	20,0±4	R	1950 VA R
1 905	1 955	1 794	32,5	65	21	d ₁ +24	d ₁ +115	50±12	R	1950 VRME R
		1 794	32,5	65	30	d ₁ +24	d ₁ +115	50±12	R	1950 VE R
		1 794	67,5	100	13	d ₁ +24	d ₁ +115	85±12	R	1950 VRM R
1 975	2 025	1 810	6	10,5	6,5	d ₁ +5	d ₁ +20	8,0±1,5	R	2000 VL R
		1 810	6	10,5	6,5	d ₁ +5	d ₁ +20	8,0±1,5	V	2000 VL V
1 970	2 020	1 810	14,3	25	15	d ₁ +10	d ₁ +45	20,0±4	R	2000 VA R
1 955	2 010	1 844	32,5	65	30	d ₁ +24	d ₁ +115	50±12	R	2000 VE R
		1 844	67,5	100	13	d ₁ +24	d ₁ +115	85±12	R	2000 VRM R

V-ring seals – inch dimensions, globally valid outside North American market

d_1 0.110 – 1.890 in.

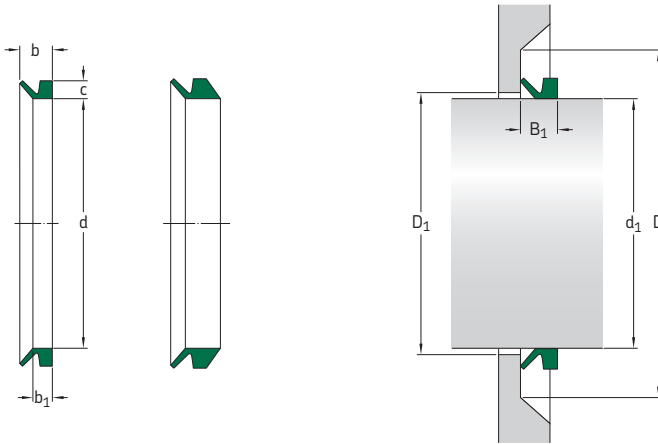

Dimensions		Ref. metric dim.	Seal inside diameter, free state d	Seal seat width b_1	Nominal seal width b	Nominal seal height c	Clearance D_1 max	Counter-face D min	Seal fitted width B_1	Lip code	Designation
Shaft diameter range d_1 over	incl.										
in.	mm	in.									
0.110	0.140	3	0.100	0.060	0.080	0.120	0.040	0.160	0.100±0.012	R	3 VA R
		3	0.100	0.060	0.080	0.120	0.040	0.160	0.100±0.012	V	3 VA V
0.140	0.180	4	0.130	0.080	0.090	0.150	0.040	0.240	0.120±0.016	R	4 VA R
		4	0.130	0.080	0.090	0.150	0.040	0.240	0.120±0.016	V	4 VA V
0.180	0.210	5	0.160	0.080	0.090	0.150	0.040	0.240	0.120±0.016	R	5 VA R
		5	0.160	0.080	0.150	0.200	0.040	0.240	0.180±0.016	R	5 VS R
		5	0.160	0.080	0.090	0.150	0.040	0.240	0.120±0.016	V	5 VA V
		5	0.160	0.080	0.150	0.200	0.040	0.240	0.180±0.016	V	5 VS V
0.210	0.260	6	0.200	0.080	0.090	0.150	0.040	0.240	0.120±0.016	R	6 VA R
		6	0.200	0.080	0.150	0.200	0.040	0.240	0.180±0.016	R	6 VS R
		6	0.200	0.080	0.090	0.150	0.040	0.240	0.120±0.016	V	6 VA V
		6	0.200	0.080	0.150	0.200	0.040	0.240	0.180±0.016	V	6 VS V
0.260	0.310	7	0.240	0.080	0.090	0.150	0.040	0.240	0.120±0.016	R	7 VA R
		7	0.240	0.080	0.150	0.200	0.040	0.240	0.180±0.016	R	7 VS R
		7	0.240	0.080	0.090	0.150	0.040	0.240	0.120±0.016	V	7 VA V
		7	0.240	0.080	0.150	0.200	0.040	0.240	0.180±0.016	V	7 VS V
0.310	0.370	8	0.280	0.080	0.090	0.150	0.040	0.240	0.120±0.016	R	8 VA R
		8	0.280	0.080	0.150	0.200	0.040	0.240	0.180±0.016	R	8 VS R
		8	0.280	0.080	0.090	0.150	0.040	0.240	0.120±0.016	V	8 VA V
		8	0.280	0.080	0.150	0.200	0.040	0.240	0.180±0.016	V	8 VS V
0.370	0.450	10	0.350	0.120	0.130	0.220	0.080	0.350	0.180±0.020	R	10 VA R
		10	0.350	0.120	0.220	0.300	0.080	0.350	0.260±0.020	R	10 VS R
		10	0.350	0.120	0.130	0.220	0.080	0.350	0.180±0.020	V	10 VA V
		10	0.350	0.120	0.220	0.300	0.080	0.350	0.260±0.020	V	10 VS V
0.450	0.530	12	0.410	0.120	0.130	0.220	0.080	0.350	0.180±0.020	R	12 VA R
		12	0.410	0.120	0.220	0.300	0.080	0.350	0.260±0.020	R	12 VS R
		12	0.410	0.120	0.130	0.220	0.080	0.350	0.180±0.020	V	12 VA V
		12	0.410	0.120	0.220	0.300	0.080	0.350	0.260±0.020	V	12 VS V
0.490	0.570	13	0.450	0.120	0.130	0.220	0.080	0.350	0.180±0.020	R	13 VA R
		13	0.450	0.120	0.130	0.220	0.080	0.350	0.180±0.020	V	13 VA V

Select the larger V-ring when the dimension d_1 is on the boundary between two sizes of V-ring.

Dimensions		Ref. metric dim.	Seal inside diameter, free state d	Seal seat width b ₁	Nominal seal width b	Nominal seal height c	Clearance D ₁ max	Counter-face D min	Seal fitted width B ₁	Lip code	Designation
Shaft diameter range d ₁ over	incl.										
in.		mm	in.							-	-
0.530	0.610	14	0.490	0.120	0.130	0.220	0.080	0.350	0.180±0.020	R	14 VA R
		14	0.490	0.120	0.220	0.300	0.080	0.350	0.260±0.020	R	14 VS R
		14	0.490	0.120	0.130	0.220	0.080	0.350	0.180±0.020	V	14 VAV
		14	0.490	0.120	0.220	0.300	0.080	0.350	0.260±0.020	V	14 VSV
0.610	0.690	16	0.550	0.120	0.130	0.220	0.080	0.350	0.180±0.020	R	16 VA R
		16	0.550	0.120	0.220	0.300	0.080	0.350	0.260±0.020	R	16 VS R
		16	0.550	0.120	0.130	0.220	0.080	0.350	0.180±0.020	V	16 VAV
		16	0.550	0.120	0.220	0.300	0.080	0.350	0.260±0.020	V	16 VSV
0.690	0.750	18	0.630	0.120	0.130	0.220	0.080	0.350	0.180±0.020	R	18 VA R
		18	0.630	0.120	0.130	0.220	0.080	0.350	0.180±0.020	V	18 VAV
0.690	0.770	18	0.630	0.120	0.220	0.300	0.080	0.350	0.260±0.020	R	18 VS R
		18	0.630	0.120	0.220	0.300	0.080	0.350	0.260±0.020	V	18 VSV
0.750	0.830	20	0.710	0.160	0.190	0.300	0.080	0.470	0.240±0.030	R	20 VA R
		20	0.710	0.160	0.190	0.300	0.080	0.470	0.240±0.030	V	20 VAV
0.770	0.830	20	0.710	0.160	0.310	0.410	0.080	0.470	0.350±0.030	R	20 VS R
		20	0.710	0.160	0.310	0.410	0.080	0.470	0.350±0.030	V	20 VSV
0.830	0.950	22	0.790	0.160	0.190	0.300	0.080	0.470	0.240±0.030	R	22 VA R
		22	0.790	0.160	0.310	0.410	0.080	0.470	0.350±0.030	R	22 VS R
		22	0.790	0.160	0.190	0.300	0.080	0.470	0.240±0.030	V	22 VAV
		22	0.790	0.160	0.310	0.410	0.080	0.470	0.350±0.030	V	22 VSV
0.950	1.070	25	0.870	0.160	0.190	0.300	0.080	0.470	0.240±0.030	R	25 VA R
		25	0.870	0.160	0.310	0.410	0.080	0.470	0.350±0.030	R	25 VS R
		25	0.870	0.160	0.190	0.300	0.080	0.470	0.240±0.030	V	25 VAV
		25	0.870	0.160	0.310	0.410	0.080	0.470	0.350±0.030	V	25 VSV
1.070	1.140	28	0.980	0.160	0.190	0.300	0.120	0.470	0.240±0.030	R	28 VA R
		28	0.980	0.160	0.310	0.410	0.120	0.470	0.350±0.030	R	28 VS R
		28	0.980	0.160	0.190	0.300	0.120	0.470	0.240±0.030	V	28 VAV
		28	0.980	0.160	0.310	0.410	0.120	0.470	0.350±0.030	V	28 VSV
1.140	1.220	30	1.060	0.160	0.190	0.300	0.120	0.470	0.240±0.030	R	30 VA R
		30	1.060	0.160	0.310	0.410	0.120	0.470	0.350±0.030	R	30 VS R
		30	1.060	0.160	0.190	0.300	0.120	0.470	0.240±0.030	V	30 VAV
		30	1.060	0.160	0.310	0.410	0.120	0.470	0.350±0.030	V	30 VSV
1.220	1.300	32	1.140	0.160	0.190	0.300	0.120	0.470	0.240±0.030	R	32 VA R
		32	1.140	0.160	0.310	0.410	0.120	0.470	0.350±0.030	R	32 VS R
		32	1.140	0.160	0.190	0.300	0.120	0.470	0.240±0.030	V	32 VAV
		32	1.140	0.160	0.310	0.410	0.120	0.470	0.350±0.030	V	32 VSV
1.300	1.420	35	1.220	0.160	0.190	0.300	0.120	0.470	0.240±0.030	R	35 VA R
		35	1.220	0.160	0.310	0.410	0.120	0.470	0.350±0.030	R	35 VS R
		35	1.220	0.160	0.190	0.300	0.120	0.470	0.240±0.030	V	35 VAV
		35	1.220	0.160	0.310	0.410	0.120	0.470	0.350±0.030	V	35 VSV
1.420	1.500	38	1.340	0.160	0.190	0.300	0.120	0.470	0.240±0.030	R	38 VA R
		38	1.340	0.160	0.310	0.410	0.120	0.470	0.350±0.030	R	38 VS R
		38	1.340	0.160	0.190	0.300	0.120	0.470	0.240±0.030	V	38 VAV
		38	1.340	0.160	0.310	0.410	0.120	0.470	0.350±0.030	V	38 VSV
1.500	1.700	40	1.420	0.200	0.220	0.350	0.120	0.590	0.280±0.040	R	40 VA R
		40	1.420	0.200	0.370	0.510	0.120	0.590	0.430±0.040	R	40 VS R
		40	1.420	0.200	0.220	0.350	0.120	0.590	0.280±0.040	V	40 VAV
		40	1.420	0.200	0.370	0.510	0.120	0.590	0.430±0.040	V	40 VSV
1.700	1.890	45	1.570	0.200	0.220	0.350	0.120	0.590	0.280±0.040	R	45 VA R
		45	1.570	0.200	0.370	0.510	0.120	0.590	0.430±0.040	R	45 VS R
		45	1.570	0.200	0.220	0.350	0.120	0.590	0.280±0.040	V	45 VAV
		45	1.570	0.200	0.370	0.510	0.120	0.590	0.430±0.040	V	45 VSV

7.2

V-ring seals – inch dimensions, globally valid outside North American market

d_1 1.890 – 7.290 in.

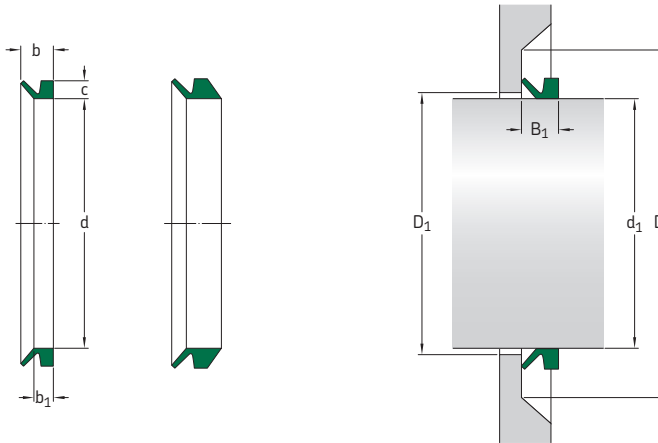

Dimensions		Ref. metric dim.	Seal inside diameter, free state d	Seal seat width b_1	Nominal seal width b	Nominal seal height c	Clearance D_1 max	Counter-face D min	Seal fitted width B_1	Lip code	Designation
Shaft diameter range d_1 over	incl.										
in.	mm	in.									
1.890	2.090	50	1.770	0.200	0.220	0.350	0.120	0.590	0.280±0.040	R	50 VA R
		50	1.770	0.200	0.370	0.510	0.120	0.590	0.430±0.040	R	50 VS R
		50	1.770	0.200	0.220	0.350	0.120	0.590	0.280±0.040	V	50 VAV
		50	1.770	0.200	0.370	0.510	0.120	0.590	0.430±0.040	V	50 VSV
2.090	2.290	55	1.930	0.200	0.220	0.350	0.120	0.590	0.280±0.040	R	55 VA R
		55	1.930	0.200	0.370	0.510	0.120	0.590	0.430±0.040	R	55 VS R
		55	1.930	0.200	0.220	0.350	0.120	0.590	0.280±0.040	V	55 VAV
		55	1.930	0.200	0.370	0.510	0.120	0.590	0.430±0.040	V	55 VSV
2.290	2.480	60	2.130	0.200	0.220	0.350	0.120	0.590	0.280±0.040	R	60 VA R
		60	2.130	0.200	0.370	0.510	0.120	0.590	0.430±0.040	R	60 VS R
		60	2.130	0.200	0.220	0.350	0.120	0.590	0.280±0.040	V	60 VAV
		60	2.130	0.200	0.370	0.510	0.120	0.590	0.430±0.040	V	60 VSV
2.480	2.680	65	2.280	0.200	0.220	0.350	0.120	0.590	0.280±0.040	R	65 VA R
		65	2.280	0.200	0.370	0.510	0.120	0.590	0.430±0.040	R	65 VS R
		65	2.280	0.200	0.220	0.350	0.120	0.590	0.280±0.040	V	65 VAV
		65	2.280	0.200	0.370	0.510	0.120	0.590	0.430±0.040	V	65 VSV
2.680	2.880	70	2.480	0.240	0.270	0.430	0.160	0.710	0.350±0.050	R	70 VA R
		70	2.480	0.240	0.440	0.610	0.160	0.710	0.530±0.050	R	70 VS R
		70	2.480	0.240	0.270	0.430	0.160	0.710	0.350±0.050	V	70 VAV
		70	2.480	0.240	0.440	0.610	0.160	0.710	0.530±0.050	V	70 VSV
2.880	3.070	75	2.640	0.240	0.270	0.430	0.160	0.710	0.350±0.050	R	75 VA R
		75	2.640	0.240	0.440	0.610	0.160	0.710	0.530±0.050	R	75 VS R
		75	2.640	0.240	0.270	0.430	0.160	0.710	0.350±0.050	V	75 VAV
		75	2.640	0.240	0.440	0.610	0.160	0.710	0.530±0.050	V	75 VSV
3.070	3.270	80	2.830	0.240	0.270	0.430	0.160	0.710	0.350±0.050	R	80 VA R
		80	2.830	0.240	0.440	0.610	0.160	0.710	0.530±0.050	R	80 VS R
		80	2.830	0.240	0.270	0.430	0.160	0.710	0.350±0.050	V	80 VAV
		80	2.830	0.240	0.440	0.610	0.160	0.710	0.530±0.050	V	80 VSV
3.270	3.470	85	2.990	0.240	0.270	0.430	0.160	0.710	0.350±0.050	R	85 VA R
		85	2.940	0.240	0.440	0.610	0.160	0.710	0.530±0.050	R	85 VS R
		85	2.990	0.240	0.270	0.430	0.160	0.710	0.350±0.050	V	85 VAV
		85	2.940	0.240	0.440	0.610	0.160	0.710	0.530±0.050	V	85 VSV

Select the larger V-ring when the dimension d_1 is on the boundary between two sizes of V-ring.

Dimensions		Ref. metric dim.	Seal inside diameter, free state d	Seal seat width b ₁	Nominal seal width b	Nominal seal height c	Clearance D ₁ max	Counter-face D min	Seal fitted width B ₁	Lip code	Designation
Shaft diameter range d ₁ over	incl.										
in.	mm	in.									
3.470	3.660	90	3.190	0.240	0.270	0.430	0.160	0.710	0.350±0.050	R	90 VA R
		90	3.190	0.240	0.440	0.610	0.160	0.710	0.530±0.050	R	90 VS R
		90	3.190	0.240	0.270	0.430	0.160	0.710	0.350±0.050	V	90 VAV
		90	3.190	0.240	0.440	0.610	0.160	0.710	0.530±0.050	V	90 VSV
3.660	3.860	95	3.350	0.240	0.270	0.430	0.160	0.710	0.350±0.050	R	95 VA R
		95	3.350	0.240	0.440	0.610	0.160	0.710	0.530±0.050	R	95 VS R
		95	3.350	0.240	0.270	0.430	0.160	0.710	0.350±0.050	V	95 VAV
		95	3.350	0.240	0.440	0.610	0.160	0.710	0.530±0.050	V	95 VSV
3.860	4.140	100	3.540	0.240	0.270	0.430	0.160	0.710	0.350±0.050	R	100 VA R
		100	3.540	0.240	0.440	0.610	0.160	0.710	0.530±0.050	R	100 VS R
		100	3.540	0.240	0.270	0.430	0.160	0.710	0.350±0.050	V	100 VAV
		100	3.540	0.240	0.440	0.610	0.160	0.710	0.530±0.050	V	100 VSV
4.140	4.530	110	3.900	0.280	0.310	0.500	0.160	0.830	0.410±0.060	R	110 VA R
		110	3.900	0.280	0.520	0.710	0.160	0.830	0.610±0.060	R	110 VS R
		110	3.900	0.280	0.310	0.500	0.160	0.830	0.410±0.060	V	110 VAV
		110	3.900	0.280	0.520	0.710	0.160	0.830	0.610±0.060	V	110 VSV
4.530	4.920	120	4.250	0.280	0.310	0.500	0.160	0.830	0.410±0.060	R	120 VA R
		120	4.250	0.280	0.520	0.710	0.160	0.830	0.610±0.060	R	120 VS R
		120	4.250	0.260	0.240	0.410	0.200	0.800	0.315±0.060	V	120 VL R
		120	4.250	0.280	0.310	0.500	0.160	0.830	0.410±0.060	V	120 VAV
		120	4.250	0.280	0.520	0.710	0.160	0.830	0.610±0.060	V	120 VSV
4.920	5.320	130	4.610	0.280	0.310	0.500	0.160	0.830	0.410±0.060	R	130 VA R
		130	4.610	0.280	0.520	0.710	0.160	0.830	0.610±0.060	R	130 VS R
		130	4.610	0.280	0.310	0.500	0.160	0.830	0.410±0.060	V	130 VAV
		130	4.610	0.280	0.520	0.710	0.160	0.830	0.610±0.060	V	130 VSV
5.320	5.710	140	4.960	0.280	0.310	0.500	0.160	0.830	0.410±0.060	R	140 VA R
		140	4.960	0.280	0.520	0.710	0.160	0.830	0.610±0.060	R	140 VS R
		140	4.960	0.260	0.240	0.410	0.200	0.800	0.310±0.060	R	140 VL R
		140	4.960	0.280	0.310	0.500	0.160	0.830	0.410±0.060	V	140 VAV
		140	4.960	0.280	0.520	0.710	0.160	0.830	0.610±0.060	V	140 VSV
		140	4.960	0.260	0.240	0.410	0.200	0.800	0.310±0.060	V	140 VL V
5.710	6.100	150	5.310	0.280	0.310	0.500	0.160	0.830	0.410±0.060	R	150 VA R
		150	5.310	0.280	0.520	0.710	0.160	0.830	0.610±0.060	R	150 VS R
		150	5.310	0.260	0.240	0.410	0.200	0.800	0.310±0.060	R	150 VL R
		150	5.310	0.280	0.310	0.500	0.160	0.830	0.410±0.060	V	150 VAV
		150	5.310	0.280	0.520	0.710	0.160	0.830	0.610±0.060	V	150 VSV
		150	5.310	0.260	0.240	0.410	0.200	0.800	0.310±0.060	V	150 VL V
6.100	6.500	160	5.670	0.310	0.350	0.570	0.200	0.940	0.470±0.070	R	160 VA R
		160	5.670	0.310	0.590	0.810	0.200	0.940	0.710±0.070	R	160 VS R
		160	5.670	0.260	0.240	0.410	0.200	0.800	0.310±0.060	R	160 VL R
		160	5.670	0.310	0.350	0.570	0.200	0.940	0.470±0.070	V	160 VAV
		160	5.670	0.310	0.590	0.810	0.200	0.940	0.710±0.070	V	160 VSV
		160	5.670	0.260	0.240	0.410	0.200	0.800	0.310±0.060	V	160 VL V
6.500	6.890	170	6.020	0.310	0.350	0.570	0.200	0.940	0.470±0.070	R	170 VA R
		170	6.020	0.310	0.590	0.810	0.200	0.940	0.710±0.070	R	170 VS R
		170	6.020	0.260	0.240	0.410	0.200	0.800	0.310±0.060	R	170 VL R
		170	6.020	0.310	0.350	0.570	0.200	0.940	0.470±0.070	V	170 VAV
		170	6.020	0.310	0.590	0.810	0.200	0.940	0.710±0.070	V	170 VSV
		170	6.020	0.260	0.240	0.410	0.200	0.800	0.310±0.060	V	170 VL V
6.890	7.290	180	6.380	0.310	0.350	0.570	0.200	0.940	0.470±0.070	R	180 VA R
		180	6.380	0.310	0.590	0.810	0.200	0.940	0.710±0.070	R	180 VS R
		180	6.380	0.260	0.240	0.410	0.200	0.800	0.310±0.060	R	180 VL R
		180	6.380	0.310	0.350	0.570	0.200	0.940	0.470±0.070	V	180 VAV
		180	6.380	0.310	0.590	0.810	0.200	0.940	0.710±0.070	V	180 VSV
		180	6.380	0.260	0.240	0.410	0.200	0.800	0.310±0.060	V	180 VL V

V-ring seals – inch dimensions, globally valid outside North American market
d₁ 7.290 – 19.090 in.

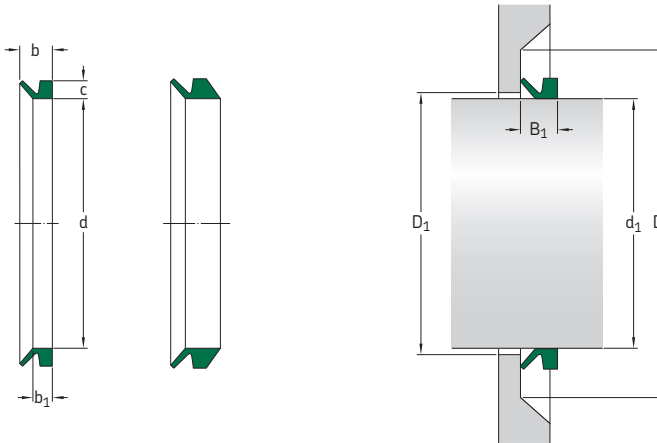

Dimensions		Ref. metric dim.	Seal inside diameter, free state d	Seal seat width b ₁	Nominal seal width b	Nominal seal height c	Clearance D ₁ max	Counter-face D min	Seal fitted width B ₁	Lip code	Designation
Shaft diameter range d ₁ over	incl.										
in.	mm	mm	in.							-	-
7.290	7.680	190	6.730	0.310	0.350	0.570	0.200	0.940	0.470±0.070	R	190 VA R
		190	6.730	0.310	0.590	0.810	0.200	0.940	0.710±0.070	R	190 VS R
		190	6.730	0.260	0.240	0.410	0.200	0.800	0.310±0.060	R	190 VL R
		190	6.730	0.310	0.350	0.570	0.200	0.940	0.470±0.070	V	190 VA V
		190	6.730	0.310	0.590	0.810	0.200	0.940	0.710±0.070	V	190 VS V
		190	6.730	0.260	0.240	0.410	0.200	0.800	0.310±0.060	V	190 VL V
7.480	8.270	200	7.090	0.590	0.560	0.980	0.400	1.770	0.790±0.160	R	200 VA R
		200	7.090	0.590	0.560	0.980	0.400	1.770	0.790±0.160	V	200 VA V
7.680	8.270	199	7.090	0.310	0.350	0.570	0.200	0.940	0.470±0.070	R	199 VA R
		199	7.090	0.310	0.590	0.810	0.200	0.940	0.710±0.070	R	199 VS R
		199	7.090	0.310	0.350	0.570	0.200	0.940	0.470±0.070	V	199 VA V
		199	7.090	0.310	0.590	0.810	0.200	0.940	0.710±0.070	V	199 VS V
		200	7.170	0.260	0.240	0.410	0.200	0.800	0.310±0.060	R	200 VL R
		200	7.170	0.260	0.240	0.410	0.200	0.800	0.310±0.060	V	200 VL V
8.270	9.170	220	7.800	0.260	0.240	0.410	0.200	0.800	0.310±0.060	R	220 VL R
		220	7.800	0.260	0.240	0.410	0.200	0.800	0.310±0.060	V	220 VL V
8.270	9.250	220	7.800	0.590	0.560	0.980	0.400	1.770	0.790±0.160	R	220 VA R
		220	7.800	0.590	0.560	0.980	0.400	1.770	0.790±0.160	V	220 VA V
9.170	10.240	250	8.860	0.260	0.240	0.410	0.200	0.800	0.310±0.060	R	250 VL R
		250	8.860	0.260	0.240	0.410	0.200	0.800	0.310±0.060	V	250 VL V
9.250	10.430	250	8.860	0.590	0.560	0.980	0.400	1.770	0.790±0.160	R	250 VA R
		250	8.860	0.590	0.560	0.980	0.400	1.770	0.790±0.160	V	250 VA V
10.240	11.220	275	9.720	0.260	0.240	0.410	0.200	0.800	0.310±0.060	R	275 VL R
		275	9.720	0.260	0.240	0.410	0.200	0.800	0.310±0.060	V	275 VL V
10.430	11.420	275	9.720	0.590	0.560	0.980	0.400	1.770	0.790±0.160	R	275 VA R
		275	9.720	0.590	0.560	0.980	0.400	1.770	0.790±0.160	V	275 VA V
11.220	12.200	300	10.630	0.260	0.240	0.410	0.200	0.800	0.310±0.060	R	300 VL R
		300	10.630	0.260	0.240	0.410	0.200	0.800	0.310±0.060	V	300 VL V
11.420	12.200	300	10.630	0.590	0.560	0.980	0.400	1.770	0.790±0.160	R	300 VA R
		300	10.630	0.590	0.560	0.980	0.400	1.770	0.790±0.160	V	300 VA V

Select the larger V-ring when the dimension d₁ is on the boundary between two sizes of V-ring.

Dimensions		Ref. metric dim.	Seal inside diameter, free state d	Seal seat width b ₁	Nominal seal width b	Nominal seal height c	Clearance D ₁ max	Counter-face D min	Seal fitted width B ₁	Lip code	Designation
Shaft diameter range d ₁ over	incl.										
in.		mm	in.							-	-
11.811	12.000	300	11.575	0.827	2.657	3.931	0.940	4.530	3.350±0.500	R	300 VRM R
12.200	13.190	325	11.500	0.590	0.560	0.980	0.400	1.770	0.790±0.160	R	325 VA R
		325	11.500	0.260	0.240	0.410	0.200	0.800	0.310±0.060	R	325 VL R
		325	11.500	0.590	0.560	0.980	0.400	1.770	0.790±0.160	V	325 VAV
		325	11.500	0.260	0.240	0.410	0.200	0.800	0.310±0.060	V	325 VL V
12.400	12.600	315	12.170	1.180	1.280	2.560	0.940	4.530	2.000±0.500	R	315 VE R
13.190	14.370	350	12.400	0.590	0.560	0.980	0.400	1.770	0.790±0.160	R	350 VA R
		350	12.400	0.260	0.240	0.410	0.200	0.800	0.310±0.060	R	350 VL R
		350	12.400	0.590	0.560	0.980	0.400	1.770	0.790±0.160	V	350 VAV
		350	12.400	0.260	0.240	0.410	0.200	0.800	0.310±0.060	V	350 VL V
14.170	14.370	360	13.858	1.181	1.280	2.559	0.945	4.528	1.969±0.472	R	360 VE R
		360	13.858	1.180	1.280	2.560	0.940	4.530	2.000±0.500	V	360 VE V
14.350	15.550	390	15.000	1.180	1.280	2.560	0.940	4.530	2.000±0.500	R	390 VE R
14.370	15.150	375	13.270	0.260	0.240	0.410	0.200	0.800	0.310±0.060	R	375 VL R
		375	13.270	0.260	0.240	0.410	0.200	0.800	0.310±0.060	V	375 VL V
14.370	15.350	375	13.270	0.590	0.560	0.980	0.400	1.770	0.790±0.160	R	375 VA R
		375	13.270	0.590	0.560	0.980	0.400	1.770	0.790±0.160	V	375 VAV
14.567	14.764	370	14.252	1.180	1.280	2.560	0.940	4.530	2.000±0.500	R	370 VE R
14.764	14.961	375	14.449	1.180	1.280	2.560	0.940	4.530	2.000±0.500	R	375 VE R
14.961	15.157	380	14.606	0.827	2.657	3.937	0.940	4.530	3.350±0.500	R	380 VRM R
15.150	16.730	400	14.170	0.260	0.240	0.410	0.200	0.800	0.310±0.060	R	400 VL R
15.150	16.930	400	14.170	0.260	0.240	0.410	0.200	0.800	0.310±0.060	V	400 VL V
15.350	16.930	400	14.170	0.590	0.560	0.980	0.400	1.770	0.790±0.160	R	400 VA R
		400	14.170	0.590	0.560	0.980	0.400	1.770	0.790±0.160	V	400 VAV
15.354	19.685	385	14.803	0.827	2.657	3.937	0.940	4.530	3.350±0.500	R	385 VRM R
15.750	15.940	400	15.394	1.181	1.280	2.559	0.945	4.528	1.969±0.472	R	400 VE R
16.142	17.322	425	15.039	0.260	0.240	0.410	0.200	0.800	0.315±0.060	R	425 VL R
16.730	18.700	450	15.940	0.260	0.240	0.410	0.200	0.800	0.310±0.060	R	450 VL R
		450	15.940	0.260	0.240	0.410	0.200	0.800	0.310±0.060	V	450 VL V
16.930	17.120	430	16.490	1.180	1.280	2.560	0.940	4.530	2.000±0.500	R	430 VE R
16.930	18.900	450	15.940	0.590	0.560	0.980	0.400	1.770	0.790±0.160	R	450 VA R
		450	15.940	0.590	0.560	0.980	0.400	1.770	0.790±0.160	V	450 VAV
17.720	17.910	450	17.280	1.180	1.280	2.560	0.940	4.530	2.000±0.500	R	450 VE R
18.110	18.310	460	17.640	1.180	1.280	2.560	0.940	4.530	5.000±0.500	R	460 VE R
18.500	18.700	470	18.030	1.180	1.280	2.560	0.940	4.530	2.000±0.500	R	470 VE R
18.700	18.900	475	18.228	1.180	1.280	2.560	0.940	4.530	2.000±0.500	R	475 VE R
		475	18.228	1.180	1.280	2.560	0.940	4.530	2.000±0.500	V	475 VE V
18.700	20.080	500	17.717	0.255	0.236	0.413	0.196	0.787	0.315±0.060	R	500 VL V
18.900	19.090	480	18.430	1.180	1.280	2.560	0.940	4.530	2.000±0.500	R	480 VE R
		480	18.430	1.180	1.280	2.560	0.940	4.530	2.000±0.500	V	480 VE V

7.2

V-ring seals – inch dimensions, globally valid outside North American market
d₁ 18.900 – 30.830 in.

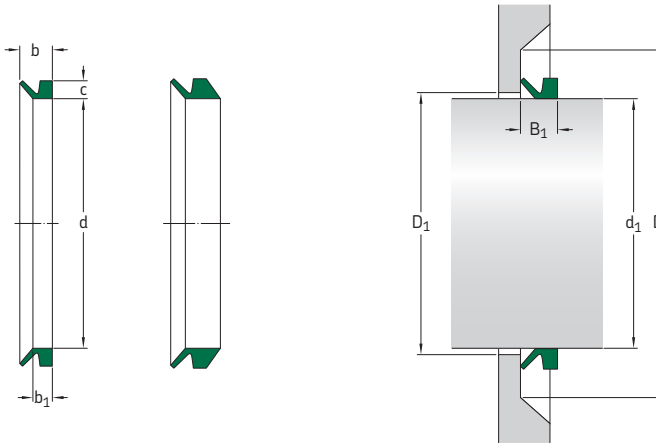

Dimensions		Ref. metric dim.	Seal inside diameter, free state d	Seal seat width b ₁	Nominal seal width b	Nominal seal height c	Clearance D ₁ max	Counter-face D min	Seal fitted width B ₁	Lip code	Designation
Shaft diameter range d ₁ over	incl.										
in.	mm	in.								-	-
18.900	20.870	500	17.720	0.590	0.560	0.980	0.400	1.770	0.790±0.160	R	500 VA R
		500	17.720	0.260	0.240	0.410	0.200	0.800	0.310±0.060	R	500 VL R
		500	17.720	0.590	0.560	0.980	0.400	1.770	0.790±0.160	V	500 VAV
19.090	19.290	485	18.622	1.181	1.280	2.559	0.945	4.528	1.969±0.472	R	485 VE R
19.100	19.290	485	19.094	1.180	1.280	2.560	0.940	4.530	2.000±0.500	V	485 VE V
19.290	19.490	490	18.820	1.180	1.280	2.560	0.940	4.530	2.000±0.500	R	490 VE R
19.690	19.880	500	19.210	1.180	1.280	2.560	0.940	4.530	2.000±0.500	R	500 VE R
		500	19.213	1.180	1.280	2.560	0.940	4.530	2.000±0.500	V	500 VE V
19.910	18.110	455	17.480	1.180	1.280	2.560	0.940	4.530	2.000±0.500	R	455 VE R
20.010	20.280	510	19.570	1.180	1.280	2.560	0.940	4.530	2.000±0.500	R	510 VE R
20.080	21.260	525	18.580	0.260	0.240	0.410	0.200	0.800	0.310±0.060	R	525 VL R
20.470	20.670	520	19.960	1.180	1.280	2.560	0.940	4.530	2.000±0.500	R	520 VE R
20.870	21.060	530	20.350	1.180	1.280	2.560	0.940	4.530	2.000±0.500	R	530 VE R
20.870	22.830	550	19.490	0.590	0.560	0.980	0.400	1.770	0.790±0.160	R	550 VA R
		550	19.490	0.260	0.240	0.410	0.200	0.800	0.310±0.060	R	550 VL R
		550	19.490	0.590	0.560	0.980	0.400	1.770	0.790±0.160	V	550 VAV
21.260	21.460	540	20.709	1.180	1.280	2.560	0.940	4.530	2.000±0.500	R	540 VE R
21.560	22.638	550	19.488	0.260	0.240	0.410	0.200	0.800	0.315±0.060	V	550 VL V
21.650	21.850	550	21.100	1.180	1.280	2.560	0.940	4.530	2.000±0.500	R	550 VE R
22.050	22.240	560	21.496	1.181	1.280	2.559	0.945	4.528	1.969±0.472	R	560 VE R
		560	21.496	1.180	1.280	2.560	0.940	4.530	2.000±0.500	V	560 VE V
22.440	22.640	570	21.850	1.180	1.280	2.560	0.940	4.530	2.000±0.500	R	570 VE R
22.638	22.835	575	22.047	1.180	1.280	2.560	0.940	4.530	2.000±0.500	V	575 VE V

Select the larger V-ring when the dimension d₁ is on the boundary between two sizes of V-ring.

Dimensions		Ref. metric dim.	Seal inside diameter, free state d	Seal seat width b ₁	Nominal seal width b	Nominal seal height c	Clearance D ₁ max	Counter-face D min	Seal fitted width B ₁	Lip code	Designation
Shaft diameter range d ₁ over	incl.										
in.	mm	in.								-	-
22.638	24.606	600	21.260	0.260	0.240	0.410	0.200	0.800	0.315±0.060	V	600 VL V
22.640	22.830	575	22.050	1.180	1.280	2.560	0.940	4.530	2.000±0.500	R	575 VE R
22.830	23.030	580	22.240	1.180	1.280	2.560	0.940	4.530	2.000±0.500	R	580 VE R
22.830	24.800	600 600 600	21.260 21.260 21.260	0.590 0.260 0.590	0.560 0.240 0.560	0.980 0.410 0.980	0.400 0.200 0.400	1.770 0.800 1.770	0.790±0.160 0.310±0.060 0.790±0.160	R R V	600 VA R 600 VL R 600 VAV
23.230	23.620	590	22.640	1.180	1.280	2.560	0.940	4.530	2.000±0.500	R	590 VE R
23.620	24.020	600	22.910	1.180	1.280	2.560	0.940	4.530	2.000±0.500	R	600 VE R
24.020	24.410	610	23.310	1.180	1.280	2.560	0.940	4.530	2.000±0.500	R	610 VE R
24.410	24.800	620	23.700	1.180	1.280	2.560	0.940	4.530	2.000±0.500	R	620 VE R
24.790	26.187	650	23.622	0.590	0.560	0.980	0.400	1.770	0.790±0.160	V	650 VAV
24.800	25.200	630	24.090	1.180	1.280	2.560	0.940	4.530	2.000±0.500	R	630 VE R
24.800	26.180	650	23.620	0.590	0.560	0.980	0.400	1.770	0.790±0.160	R	650 VA R
25.200	25.590	640	24.450	1.180	1.280	2.560	0.940	4.530	2.000±0.500	R	640 VE R
25.590	25.980	650 650	24.840 24.842	1.180 1.180	1.280 1.280	2.560 2.560	0.940 0.940	4.530 4.530	2.000±0.500 2.000±0.500	R V	650 VE R 650 VE V
25.980	26.380	660	25.197	1.180	1.280	2.560	0.940	4.530	2.000±0.500	R	660 VE R
26.180	27.760	700 700	24.800 24.803	0.590 0.590	0.560 0.560	0.980 0.980	0.400 0.400	1.770 1.770	0.790±0.160 0.790±0.160	R V	700 VA R 700 VAV
26.380	26.770	670	25.591	1.180	1.280	2.560	0.940	4.530	2.000±0.500	N	670 VE R
26.770	27.170	680	25.984	1.180	1.280	2.560	0.940	4.530	2.000±0.500	N	680 VE R
27.170	27.560	690 690	26.380 26.378	1.180 1.180	1.280 1.280	2.560 2.560	0.940 0.940	4.530 4.530	2.000±0.500 2.000±0.500	R V	690 VE R 690 VE V
27.560	27.950	700	26.780	1.180	1.280	2.560	0.940	4.530	2.000±0.500	R	700 VE R
27.760	29.330	725	26.380	0.590	0.560	0.980	0.400	1.770	0.790±0.160	R	725 VA R
27.953	28.346	710	27.126	1.180	1.280	2.560	0.940	4.530	2.000±0.500	R	710 VE R
28.350	28.740	720	27.520	1.180	1.280	2.560	0.940	4.530	2.000±0.500	R	720 VE R
28.740	29.134	730 730	27.910 27.913	1.180 1.180	1.280 1.280	2.560 2.560	0.940 0.940	4.530 4.530	2.000±0.500 2.500±0.500	R V	730 VE R 730 VE V
29.130	29.530	740	28.270	1.180	1.280	2.560	0.940	4.530	2.000±0.500	R	740 VE R
29.134	30.512	750	29.528	0.260	0.240	0.410	0.200	0.800	0.315±0.060	R	750 VL R
29.330	30.900	750	27.756	0.590	0.560	0.980	0.400	1.770	0.790±0.160	V	750 VAV
29.330	30.910	750	27.760	0.590	0.560	0.980	0.400	1.770	0.790±0.160	R	750 VA R
29.530	29.840	750	28.660	1.180	1.280	2.560	0.940	4.530	2.000±0.500	R	750 VE R
29.845	30.157	760	28.937	1.181	1.280	2.559	0.945	4.528	1.969±0.472	R	760 VE R
30.157	30.472	770	29.250	1.181	1.280	2.559	0.945	4.528	1.969±0.472	R	770 VE R
30.470	30.830	780	29.570	1.180	1.280	2.560	0.940	4.530	2.000±0.500	R	780 VE R

7.2

V-ring seals – inch dimensions, globally valid outside North American market
d₁ 30.900 – 57.870 in.

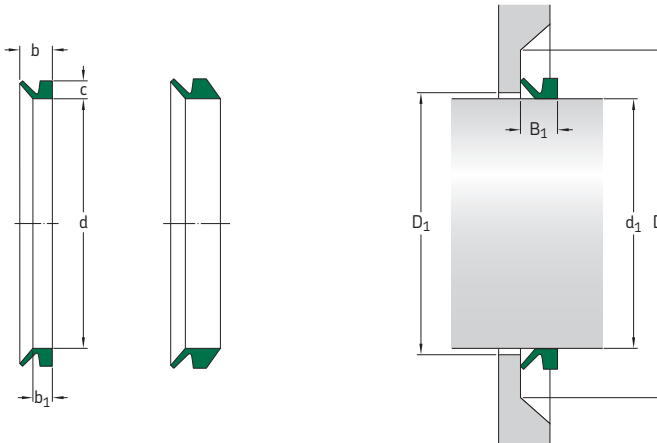

Dimensions		Ref. metric dim.	Seal inside diameter, free state d	Seal seat width b ₁	Nominal seal width b	Nominal seal height c	Clearance D ₁ max	Counter-face D min	Seal fitted width B ₁	Lip code	Designation
Shaft diameter range d ₁ over	incl.										
in.	mm	in.								-	-
30.900	32.680	800	29.330	0.590	0.560	0.980	0.400	1.770	0.790±0.160	V	800 VAV
30.910	32.680	800	29.330	0.590	0.560	0.980	0.400	1.770	0.790±0.160	R	800 VAR
31.180	31.540	800	30.240	1.180	1.280	2.560	0.940	4.530	2.000±0.500	R	800 VER
32.680	34.450	850	30.910	0.590	0.560	0.980	0.400	1.770	0.790±0.160	R	850 VAR
32.720	33.110	840	31.693	1.181	1.280	2.560	0.940	4.530	2.500±0.500	R	840 VER
33.110	33.500	850	32.050	1.180	1.280	2.560	0.940	4.530	2.000±0.500	R	850 VER
33.900	34.290	870	32.795	1.180	1.280	2.560	0.940	4.530	2.000±0.500	R	870 VER
34.290	34.720	880	33.189	1.180	1.280	2.560	0.940	4.530	2.000±0.500	R	880 VER
		880	33.189	1.180	1.280	2.560	0.940	4.530	2.000±0.500	V	880 VEV
34.449	36.417	900	32.480	0.260	0.240	0.410	0.200	0.800	0.315±0.060	R	900 VL R
34.450	36.220	890	33.583	1.180	1.280	2.560	0.940	4.530	2.000±0.500	V	890 VEV
		900	32.480	0.590	0.560	0.980	0.400	1.770	0.790±0.160	R	900 VAR
		900	32.480	0.590	0.560	0.980	0.400	1.770	0.790±0.160	V	900 VAV
34.720	35.310	890	33.580	1.180	1.280	2.560	0.940	4.530	2.000±0.500	R	890 VER
35.118	35.905	900	34.291	0.827	2.657	3.937	0.940	4.530	3.350±0.500	R	900 VRM R
35.310	35.910	900	34.290	1.180	1.280	2.560	0.940	4.530	2.000±0.500	R	900 VER
36.220	37.990	950	34.060	0.590	0.560	0.980	0.400	1.770	0.790±0.160	R	950 VAR
36.220	37.992	950	34.055	0.590	0.560	0.980	0.400	1.770	0.790±0.160	V	950 VAV
36.730	31.170	940	35.433	0.827	2.657	3.937	0.940	4.530	3.350±0.500	R	940 VRM R
36.732	37.165	940	35.433	1.180	1.280	2.560	0.940	4.530	2.000±0.500	R	940 VER
37.170	37.600	950	35.870	1.180	1.280	2.560	0.940	4.530	2.000±0.500	R	950 VER

Select the larger V-ring when the dimension d₁ is on the boundary between two sizes of V-ring.

Dimensions		Ref. metric dim.	Seal inside diameter, free state d	Seal seat width b ₁	Nominal seal width b	Nominal seal height c	Clearance D ₁ max	Counter-face D min	Seal fitted width B ₁	Lip code	Designation
Shaft diameter range d ₁ over	incl.										
in.		mm	in.							-	-
37.990	39.960	1 000 1 000	35.830 35.827	0.590 0.590	0.560 0.560	0.980 0.980	0.400 0.400	1.770 1.770	0.790±0.160 0.790±0.160	R V	1000 VA R 1000 VAV
38.898	39.331	990	37.520	1.180	1.280	2.560	0.940	4.530	2.000±0.500	R	990 VE R
39.330	39.760	1 000	37.910	1.180	1.280	2.560	0.940	4.530	2.000±0.500	R	1000 VE R
39.960	41.930	1 050	37.600	0.590	0.560	0.980	0.400	1.770	0.790±0.160	R	1050 VA R
40.550	41.350	1 050	39.340	1.180	1.280	2.560	0.940	4.530	2.000±0.500	R	1050 VE R
41.140	41.930	1 060	39.690	1.180	1.280	2.560	0.940	4.530	2.000±0.500	R	1060 VE R
41.930	42.720	1 080	40.433	1.180	1.280	2.560	0.940	4.530	2.000±0.500	R	1080 VE R
41.930	43.900	1 100	39.370	0.590	0.560	0.980	0.400	1.770	0.790±0.160	R	1100 VA R
42.720	43.500	1 100	41.140	1.180	1.280	2.560	0.940	4.530	2.000±0.500	R	1100 VE R
43.500	44.290	1 120	41.929	1.180	1.280	2.560	0.940	4.530	2.000±0.500	R	1120 VE R
43.900	45.870	1 150	41.140	0.590	0.560	0.980	0.400	1.770	0.790±0.160	R	1150 VA R
44.290	46.260	1 150	41.142	0.260	0.240	0.410	0.200	0.800	0.315±0.060	R	1150 VL R
44.291	45.079	1 140	42.677	0.827	2.657	3.937	0.940	4.530	3.350±0.500	R	1140 VRM R
44.490	45.290	1 150	43.060	1.180	1.280	2.560	0.940	4.530	2.000±0.500	R	1150 VE R
45.870	46.650	1 180	44.134	1.180	1.280	2.560	0.940	4.530	2.000±0.500	R	1180 VE R
45.870	47.840	1 200	42.910	0.590	0.560	0.980	0.400	1.770	0.790±0.160	R	1200 VA R
45.875	47.840	1 200	42.913	0.590	0.560	0.980	0.400	1.770	0.790±0.160	V	1200 VAV
46.259	48.238	1 200	42.913	0.260	0.240	0.410	0.200	0.800	0.315±0.060	R	1200 VL R
46.650	47.440	1 200	44.840	1.180	1.280	2.560	0.940	4.530	2.000±0.500	R	1200 VE R
47.840	50.000	1 250 1 250	44.690 44.685	0.590 0.590	0.560 0.560	0.980 0.980	0.400 0.400	1.770 1.770	0.790±0.160 0.790±0.160	R V	1250 VA R 1250 VAV
48.230	49.020	1 240	46.299	1.180	1.280	2.560	0.940	4.530	2.000±0.500	R	1240 VE R
48.520	49.320	1 250	46.680	1.180	1.280	2.560	0.940	4.530	2.000±0.500	R	1250 VE R
50.000	50.890	1 250	47.953	1.180	1.280	2.560	0.940	4.530	2.000±0.500	R	1280 VE R
50.000	51.970	1 300	46.460	0.590	0.560	0.980	0.400	1.770	0.790±0.160	R	1300 VA R
50.980	51.770	1 300	48.820	1.180	1.280	2.560	0.940	4.530	2.000±0.500	R	1300 VE R
51.770	52.760	1 325	49.567	1.180	1.280	2.560	0.940	4.530	2.000±0.500	R	1325 VE R
51.970	53.940	1 350	48.230	0.590	0.560	0.980	0.400	1.770	0.790±0.160	R	1350 VA R
52.165	54.134	1 350	48.228	0.260	0.240	0.410	0.200	0.800	0.315±0.060	R	1350 VL R
52.760	53.740	1 350	50.430	1.180	1.280	2.560	0.940	4.530	2.000±0.500	R	1350 VE R
53.940	55.910	1 400	50.000	0.590	0.560	0.980	0.400	1.770	0.790±0.160	R	1400 VA R
54.130	56.100	1 400	50.000	0.260	0.240	0.410	0.200	0.800	0.315±0.060	V	1400 VL V
54.720	55.710	1 400	52.280	1.180	1.280	2.560	0.940	4.530	2.000±0.500	R	1400 VE R
55.190	57.870	1 450	51.772	0.590	0.560	0.980	0.400	1.770	0.790±0.160	V	1450 VAV

7.2

V-ring seals – inch dimensions, globally valid outside North American market
d₁ 55.910 – 131.890 in.

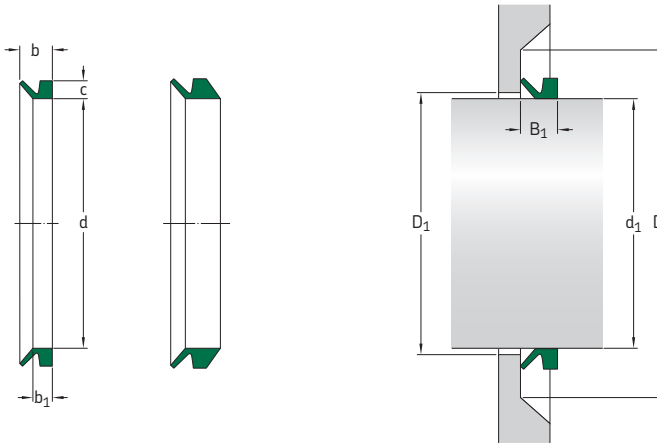

Dimensions		Ref. metric dim.	Seal inside diameter, free state d	Seal seat width b ₁	Nominal seal width b	Nominal seal height c	Clearance D ₁ max	Counter-face D min	Seal fitted width B ₁	Lip code	Designation
Shaft diameter range d ₁ over	incl.										
in.	mm	in.									
55.910	57.870	1 450	51.770	0.590	0.560	0.980	0.400	1.770	0.790±0.160	R	1450 VA R
56.690	57.680	1 450	54.090	1.180	1.280	2.560	0.940	4.530	2.000±0.500	R	1450 VE R
57.870	59.840	1 500	53.540	0.590	0.560	0.980	0.400	1.770	0.790±0.160	R	1500 VA R
58.660	59.650	1 500	55.870	1.180	1.280	2.560	0.940	4.530	2.000±0.500	R	1500 VE R
59.840	61.810	1 550	55.320	0.590	0.560	0.980	0.400	1.770	0.790±0.160	R	1550 VA R
60.630	61.810	1 550	57.760	1.180	1.280	2.560	0.940	4.530	2.000±0.500	R	1550 VE R
61.810	63.780	1 600	57.090	0.590	0.560	0.980	0.400	1.770	0.790±0.160	R	1600 VA R
62.990	64.570	1 600	60.000	1.180	1.280	2.560	0.940	4.530	2.000±0.500	R	1600 VE R
63.780	65.750	1 650	58.860	0.590	0.560	0.980	0.400	1.770	0.790±0.160	R	1650 VA R
64.570	66.140	1 650	61.380	1.180	1.280	2.560	0.940	4.530	2.000±0.500	R	1650 VE R
65.750	67.720	1 700	60.630	0.590	0.560	0.980	0.400	1.770	0.790±0.160	R	1700 VA R
66.140	67.720	1 700	62.830	1.180	1.280	2.560	0.940	4.530	2.000±0.500	R	1700 VE R
67.720	69.490	1 750	64.250	1.180	1.280	2.560	0.940	4.530	2.000±0.500	R	1750 VE R
67.720	69.690	1 750	62.400	0.590	0.560	0.980	0.400	1.770	0.790±0.160	R	1750 VA R
69.490	71.260	1 800	65.790	1.180	1.280	2.560	0.940	4.530	2.000±0.500	R	1800 VE R
69.690	71.560	1 800	64.170	0.590	0.560	0.980	0.400	1.770	0.790±0.160	R	1800 VA R
69.880	71.850	1 800	64.173	0.260	0.240	0.410	0.200	0.800	0.315±0.060	V	1800 VL V
71.260	73.030	1 850	67.480	1.180	1.280	2.560	0.940	4.530	2.000±0.500	R	1850 VE R
71.650	73.620	1 850	65.950	0.590	0.560	0.980	0.400	1.770	0.790±0.160	R	1850 VA R
73.030	75.000	1 900	69.020	1.180	1.280	2.560	0.940	4.530	2.000±0.500	R	1900 VE R

Select the larger V-ring when the dimension d₁ is on the boundary between two sizes of V-ring.

Dimensions		Ref. metric dim.	Seal inside diameter, free state d	Seal seat width b ₁	Nominal seal width b	Nominal seal height c	Clearance D ₁ max	Counter-face D min	Seal fitted width B ₁	Lip code	Designation
Shaft diameter range d ₁ over	incl.										
in.		mm	in.							-	-
73.620	75.590	1 900	67.720	0.590	0.560	0.980	0.400	1.770	0.790±0.160	R	1900 VA R
75.000	76.970	1 950	70.630	1.180	1.280	2.560	0.940	4.530	2.000±0.500	R	1950 VE R
75.590	77.560	1 950	69.490	0.590	0.560	0.980	0.400	1.770	0.790±0.160	R	1950 VA R
76.970	79.130	2 000	72.600	1.180	1.280	2.560	0.940	4.530	2.000±0.500	R	2000 VE R
77.560	79.530	2 000	71.260	0.590	0.560	0.980	0.400	1.770	0.790±0.160	R	2000 VA R
79.530	83.460	2 100	72.240	0.590	0.560	0.980	0.400	1.770	0.790±0.160	R	2100 VA R
83.360	86.420	2 150	78.660	1.180	1.280	2.560	0.940	4.530	2.000±0.520	R	2150 VE R
86.419	89.209	2 200	80.905	0.827	2.657	3.937	0.940	4.530	3.350±0.500	R	2200 VRM R
96.063	100.000	2 500	89.520	1.180	1.280	2.560	0.940	4.530	2.000±0.500	R	2500 VE R
97.358	99.543	2 500	86.020	0.590	0.560	0.980	0.400	1.770	0.790±0.160	R	2500 VA R
126.260	129.670	3 250	113.740	1.180	1.280	2.560	0.940	4.530	2.00±0.500	R	3250 VE R
127.950	131.890	3 300	115.390	1.180	1.280	2.560	0.940	4.530	2.00±0.500	R	3300 VE R

MVR axial shaft seals

General

For added protection in extremely contaminated applications, SKF also offers MVR seals. Like V-ring seals, MVR seals also seal axially and function by combining lip contact with centrifugal "flinging" action. MVR seals are, however, different from V-rings in that their rubber element is stretch fit into a metal case. The metal case is then press fit onto the shaft. The case provides excellent protection from heavy debris and enables the seal to accommodate high rotational speeds without requiring auxiliary clamping devices.

MVR seals are used in rotating shaft applications such as gearboxes, speed reducers, saws, lathes, motors, mixers, where high levels of contaminants reduce the service life of radial shaft seals and bearings. MVR seals can also serve as primary seals to retain high-viscosity lubricants or exclude contaminants in dry-running applications.

Advantages and user benefits

- The metal case serves as a support and deflector, protecting the rubber body and lip from damage and displacement by external debris like rocks and aggressive media.
- The case also often functions as a holder that keeps the rubber lip in position in high-speed applications. No additional axial retention is required.
- Narrow installation widths are possible thanks to the compact design.
- Frictional heat build-up and torque drag are very low compared to those of contacting radial shaft seals. As rotational speed increases, the MVR sealing lip lifts off the counterface surface starting at about 12 m/s (2 360 ft/min) and drops to zero contact by 20 m/s (3 900 ft/min). The high rotational speed helps exclude contaminants while minimizing power loss.
- The service life of MVR seals is considerably higher than that of radial shaft seals in contaminated environments and can extend to thousands of hours.

Design and material

The MVR seals are made of a nitrile rubber material with very good wear resistance. Other elastomers are also available on request.

The standard metal element is zinc-plated cold-rolled carbon steel. Acid-resistant steel, similar to SAE 316, is available on request.

There are two different MVR seal designs: the basic MVR1 seal and the MVR2 seal with case extension (→ fig. 11).

Temperature range

The permissible operating temperature range is between -30 and $+100$ °C (-20 and $+210$ °F).

Sizes

MVR seals are available for shaft diameters ranging from 10 to 200 mm (0.394 to 7.874 in.). Contact your SKF sales representative for comprehensive information on available sizes.

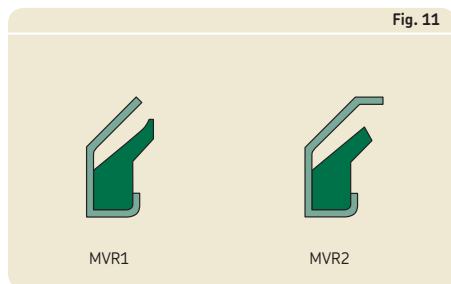

Installation

The inside diameter of MVR seals is machined for a press fit on the shaft (→ **figs. 12** and **13**). As with radial shaft seals, do not hit the metal case with a hammer.

The sealing lip face should be lightly greased prior to installation, but no grease should be applied between the lip and case. A shaft finish of $R_a\ 4\ \mu\text{m}$ ($160\ \mu\text{in.}$) is sufficient.

A lead-in chamfer should be provided. No splines or keyways are allowed.

Counterface surfaces for MVR seals should be prepared the same way as for V-rings. Avoid aluminium or soft metals in applications where there will be abrasive contaminants. Sharp peaks on turned surfaces should be removed.

Fig. 12

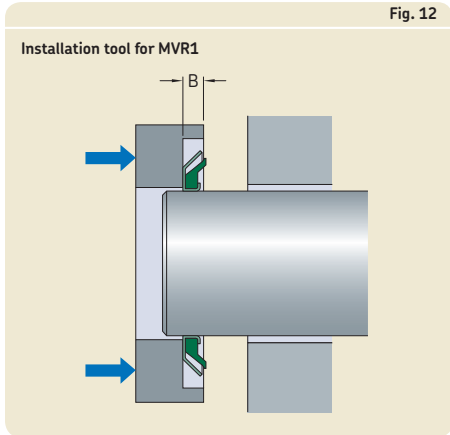
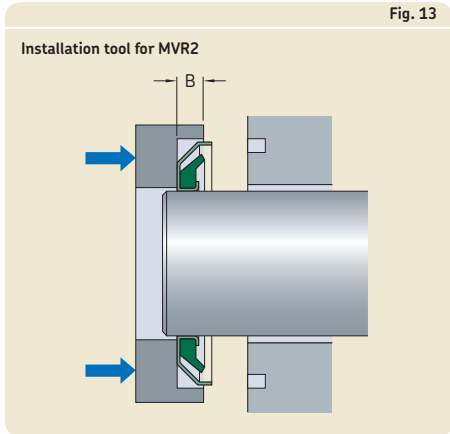
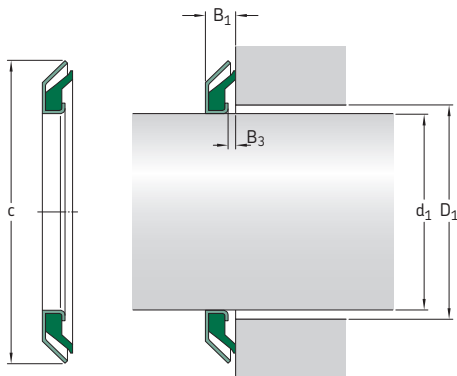

Fig. 13



Metal-cased V-ring seals – MVR1 – metric dimensions
d₁ 10 – 135 mm



Dimensions					Designation
Shaft diameter d ₁	Case outside diameter c	Seal fitted width B ₁	Gap width B ₃	Max. counterface hole diameter D ₁	
mm					-
10	24	3,5	1,0	15	CR MVR1-10
12	26	3,5	1,0	17	CR MVR1-12
15	30	4,0	1,0	21	CR MVR1-15
16	32	4,0	1,0	23	CR MVR1-16
17	32	4,0	1,0	23	CR MVR1-17
18	33	4,0	1,0	24	CR MVR1-18
20	35	4,0	1,0	26	CR MVR1-20
22	40	4,0	1,0	28	CR MVR1-22
24	40	4,0	1,0	30	CR MVR1-24
25	40	4,0	1,0	31	CR MVR1-25
26	40	4,0	1,0	32	CR MVR1-26
28	43	4,0	1,0	34	CR MVR1-28
30	47	4,5	1,0	37	CR MVR1-30
32	49	4,5	1,0	39	CR MVR1-32
35	52	4,5	1,0	42	CR MVR1-35
40	57	4,5	1,0	47	CR MVR1-40
45	62	4,5	1,0	52	CR MVR1-45
48	65	4,5	1,0	55	CR MVR1-48
50	70	5,5	1,0	58	CR MVR1-50
52	72	5,5	1,0	60	CR MVR1-52
53	73	5,5	1,0	61	CR MVR1-53
55	75	5,5	1,0	63	CR MVR1-55
58	78	5,5	1,0	66	CR MVR1-58
60	80	5,5	1,0	68	CR MVR1-60
62	82	5,5	1,0	70	CR MVR1-62
65	85	5,5	1,0	73	CR MVR1-65
68	88	5,5	1,0	76	CR MVR1-68
70	90	5,5	1,0	78	CR MVR1-70
72	92	5,5	1,0	80	CR MVR1-72
75	95	5,5	1,0	83	CR MVR1-75

Special designs are available and new sizes are added gradually.

Dimensions					Designation
Shaft diameter d_1	Case outside diameter c	Seal fitted width B_1	Gap width B_3	Max. counterface hole diameter D_1	
mm					–
78	98	5,5	1,0	86	CR MVR1-78
80	100	5,5	1,0	88	CR MVR1-80
85	105	5,5	1,0	93	CR MVR1-85
90	110	5,5	1,0	98	CR MVR1-90
95	115	5,5	1,0	103	CR MVR1-95
100	120	5,5	1,0	108	CR MVR1-100
105	125	5,5	1,0	113	CR MVR1-105
125	148	6,5	1,0	133	CR MVR1-125
135	159	6,5	1,0	145	CR MVR1-135

Metal-cased V-ring seals – MVR2 – metric dimensions

d_1 15 – 100 mm

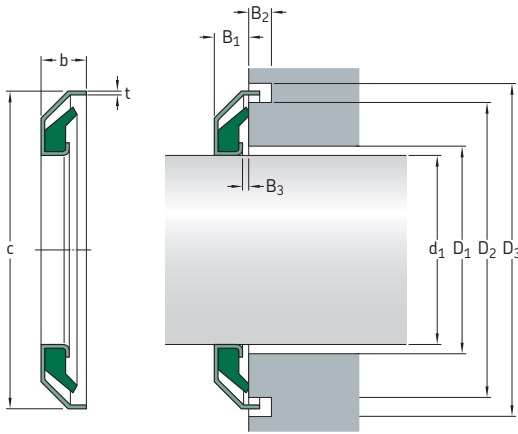

Dimensions										Designation
Shaft diameter d_1	Case outside diameter c	Seal fitted width B_1	Gap width B_3	Total seal case width b	Case groove width B_2	Seal counter-face hole D_1 max	Case groove diameter inside D_2	Case groove diameter outside D_3	Metal case thickness t	
mm										–
15	32	4,0	1,0	6,0	3	21	29	34	0,5	CR MVR2-15
17	34	4,0	1,0	6,0	3	23	31	36	0,5	CR MVR2-17
20	37	4,0	1,0	6,0	3	26	34	39	0,5	CR MVR2-20
25	42	4,0	1,0	6,0	3	31	39	44	0,5	CR MVR2-25
30	48	4,5	1,0	6,5	3	37	45	50	0,5	CR MVR2-30
35	53	4,5	1,0	6,5	3	42	50	55	0,5	CR MVR2-35
40	58	4,5	1,0	6,5	3	47	55	60	0,5	CR MVR2-40
45	63	4,5	1,0	6,5	3	52	60	65	0,5	CR MVR2-45
50	72	5,5	1,0	7,5	3	58	68,5	74	0,75	CR MVR2-50
55	77	5,5	1,0	7,5	3	63	73,5	79	0,75	CR MVR2-55
60	82	5,5	1,0	7,5	3	68	78,5	84	0,75	CR MVR2-60
65	87	5,5	1,0	7,5	3	73	83,5	89	0,75	CR MVR2-65
70	92	5,5	1,0	7,5	3	78	88,5	94	0,75	CR MVR2-70
75	95	5,5	1,0	7,5	3	83	93,5	99	0,75	CR MVR2-75
80	102	5,5	1,0	7,5	3	88	98,5	104	0,75	CR MVR2-80
85	107	5,5	1,0	7,5	3	93	103,5	109	0,75	CR MVR2-85
90	112	5,5	1,0	7,5	3	98	108,5	114	0,75	CR MVR2-90
95	117	5,5	1,0	7,5	3	103	113,5	119	0,75	CR MVR2-95
100	122	5,5	1,0	7,5	3	108	118,5	124	0,75	CR MVR2-100



Axial clamp seals

General	468
Designs	468
Design of the sealing arrangement	469
Installation instructions	470
8.1 Product table: CT1 and CT4	472

Axial clamp seals

General

SKF axial clamp seals are designed for large and very large shaft diameters. They are suitable for use as primary seals or as secondary seals in applications where the primary seals are subjected to excessive solid or fluid contaminants. Axial clamp seals do not rotate but seal axially against a rotating counterface.

SKF axial clamp seals are made of profiled strips of non-reinforced nitrile rubber and are held firmly in position by stainless steel band clamps. They are available for shaft diameters ranging from 150 to 4 600 mm (5.9 to 181 in.).

The standard range of SKF axial clamp seals is intended for inch-size shaft diameters. Because axial clamp seals are typically installed with an approximate 25 mm (0.984 in.) gap between the ends, they may also be used for metric shaft diameters.

Designs

SKF axial clamp seals are manufactured in two different designs:

- CT1 seals (→ **fig. 1**) have the basic design and are held in position by a band clamp. The maximum permissible axial displacement relative to the counterface is +2,4 mm (0.094 in.).
- CT4 seals (→ **fig. 1**) are extra wide and are designed with two band clamps. The maximum axial displacement relative to the counterface is +4,8 mm (0.189 in.).

Fig. 1

Axial clamp seal designs

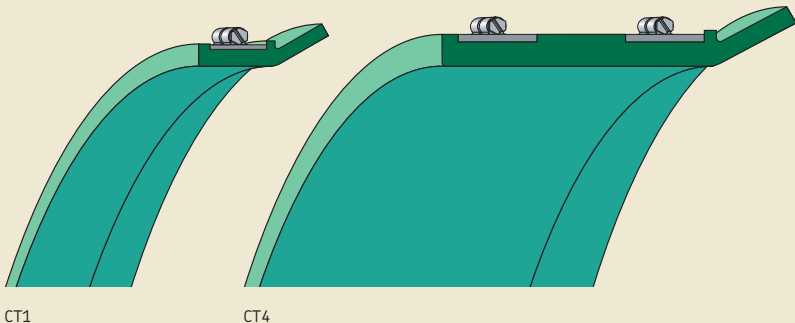

CT1

CT4

Design of the sealing arrangement

To obtain reliable sealing performance, the seal seat diameter (d_1), seal seat width (b_1) and the operating width (B_1) should meet the requirements listed in **table 1**. SKF also recommends that the seal should abut a shoulder to simplify alignment.

Finely turned counterfaces are adequate for axial clamp seals. The appropriate surface roughness values are R_a 2,5 μm (115 $\mu\text{in.}$) and R_t 12 μm (480 $\mu\text{in.}$).

Typically, after installation, CT axial clamp seals have an approximate 25 mm (1 in.) gap between the ends. This should be arranged at the 6 o'clock position (\rightarrow **fig. 2** on **page 470**) to facilitate installation and drainage of contaminants.

Butt-joint seals are also available for certain applications.

Table 1

Application tolerances

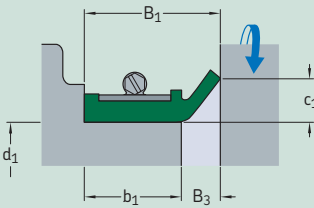

Dimension	Tolerance	Axial clamp seals	
		CT1	CT4
Seal seat diameter, d_1	mm $\pm 1,6$ in. $\pm 0,063$	152,40 – 4 572 6.000 – 180.000	304,80 – 1 143 12.000 – 45.000
Seal fitted width, B_1	mm $\pm 0,8$ in. $\pm 0,031$	28,60 – 38,10 1.125 – 1.500	38,10 – 92,20 1.500 – 3.750
Seal seat width, b_1	mm $\pm 3,2$ in. $\pm 0,125$	17,50 – 27 0.688 – 1.063	27 – 84 1.063 – 3.313
Lip height, c_1	mm $\pm 0,8$ in. $\pm 0,031$	12,70 0.500	12,70 0.500
Gap width, B_3 (max)	mm in.	11,10 0.437	11,10 0.437

Installation instructions

Axial clamp seals are supplied as rolled-up coils. They are placed in position on their seat in the housing and bolted lightly together. They are then pushed forward toward the counterface and the gap (or joint) between the two ends is arranged at the 6 o'clock position (→ **fig. 2**). The clamps are finally tightened. The torque applied to the clamp screws should not exceed 7 Nm.

Fig. 2

Sealing arrangement and installation

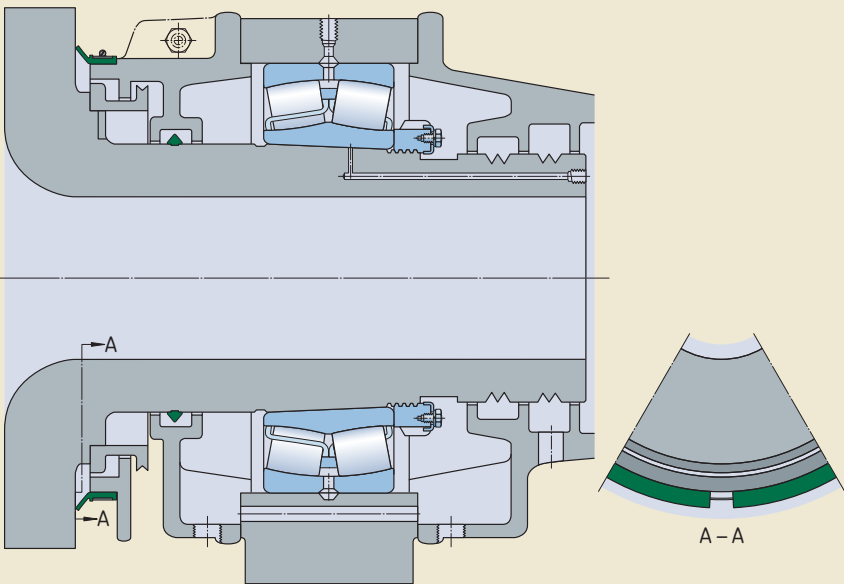

Axial clamp seals – CT1 and CT4 – metric dimensions
d₁ 168 – 1 080 mm

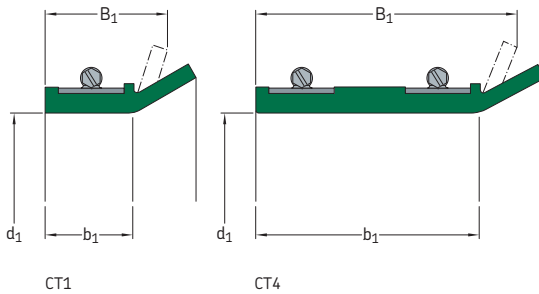

See **table 1, page 469** for application tolerances.

Dimensions			Design	Designation	Dimensions			Design	Designation
Seal seat diameter d ₁	Seal fitted width B ₁	Seal seat width b ₁			Seal seat diameter d ₁	Seal fitted width B ₁	Seal seat width b ₁		
mm			–	–	mm			–	–
168	28,60	17,50	CT1	CR 594334	381	28,60	17,50	CT1	CR 594025
168,30	28,60	17,50	CT1	CR 529489	387	28,60	17,50	CT1	CR 594954
178	38,10	27	CT1	CR 523586	410	23,80	12,70	CT1	CR 595110
185	30	18,90	CT1	CR 593637	413	88,90	77,80	CT4	CR 592934
209,60	28,60	17,50	CT1	CR 527820	425	31,80 33,40	20,70 22,30	CT1 CT1	CR 523826 CR 524815
219	28,60	17,50	CT1	CR 529490	432	38,10	27	CT1	CR 528535
227	28,60	17,50	CT1	CR 531635	444,50	34,90	23,80	CT1	CR 525737
228,60	28,60 28,60	17,50 17,50	CT1 CT1	CR 524204 CR 527819	445	31,80 34,90	20,70 23,80	CT1 CT1	CR 522679 CR 523547
229	29	17,90	CT1	CR 528631	449,30	95,30	84,20	CT4	CR 528070
254	28,60 28,60	17,50 17,50	CT1 CT1	CR 524205 CR 527806	470	28,60 31,80	17,50 20,70	CT1 CT1	CR 525708 CR 526192
273	28,60	17,50	CT1	CR 594369	495	28,60	17,50	CT1	CR 594181
280	28,60 31,80	17,50 20,70	CT1 CT1	CR 524206 CR 524928	508	31,80	20,70	CT1	CR 524587
298,40	28,60	17,50	CT1	CR 593629	533	32	20,90	CT1	CR 594241
305	31,80 38,10	20,70 27	CT1 CT1	CR 524208 CR 525582	546	31,80 95,30	20,70 84,20	CT1 CT4	CR 524599 CR 526741
330	28,60 38,10	17,50 27	CT1 CT1	CR 524209 CR 523587	554	31,80	20,70	CT1	CR 524210
350,80	38,10	27	CT1	CR 594110	557	28,60	17,50	CT1	CR 524211
355,60	38,10 34,90	27 23,80	CT1 CT1	CR 530733 CR 593037	559	31,80	20,70	CT1	CR 524347
380	38,10	27	CT1	CR 593171	571,50	31,80	20,70	CT1	CR 524212
					578	34,90	23,80	CT1	CR 524657

Dimensions		Seal fitted width B ₁	Seal seat width b ₁	Design	Designation	Dimensions		Seal fitted width B ₁	Seal seat width b ₁	Design	Designation
Seal seat diameter d ₁	mm					Seal seat diameter d ₁	mm				
594	34,90	23,80	CT1	CR 525627	876	38,10	27	CT1	CR 523063		
595	28,60	17,50	CT1	CR 525031	889	31,80	20,70	CT1	CR 524220		
597	34,90	23,80	CT1	CR 524364	900	31,80	20,70	CT1	CR 524221		
600	30	18,90	CT1	CR 594431	902	38,10	27	CT1	CR 524222		
603	31,80 34,90 46	20,70 23,80 34,90	CT1 CT1 CT4	CR 524365 CR 523184 CR 528651	914	28,60 30,20 38,10	17,50 19,10 27	CT1 CT1 CT1	CR 528416 CR 524223 CR 524224		
603,30	34,90 46	23,80 34,90	CT1 CT4	CR 525637 CR 528267	914,40	28,60 31,80	17,50 20,70	CT1 CT1	CR 593606 CR 530466		
616	47,60	36,50	CT4	CR 529276	929	28,60 75,20	17,50 64,10	CT1 CT4	CR 593285 CR 594202		
629	31,80	20,70	CT1	CR 524213	937	34,90	23,80	CT1	CR 523154		
638	34,90	23,80	CT1	CR 524214	940	38,10	27	CT1	CR 525320		
655	40	28,90	CT4	CR 594784	943	31,80	20,70	CT1	CR 524768		
660	34,90	23,80	CT1	CR 524591	946	31,80	20,70	CT1	CR 524368		
684	28,60 73	17,50 61,90	CT1 CT4	CR 524215 CR 593604	949	31,80	20,70	CT1	CR 526246		
692	34,90	23,80	CT1	CR 524592	952	31,80	20,70	CT1	CR 526582		
705	34,90 60,30	23,80 49,20	CT1 CT4	CR 524216 CR 528268	962	31,80	20,70	CT1	CR 524225		
711	31,80	20,70	CT1	CR 527232	965	31,80	20,70	CT1	CR 524226		
732	28,60	17,50	CT1	CR 525032	1 003	28,60 31,80	17,50 20,70	CT1 CT1	CR 529452 CR 526806		
737	38,10 44,50	27 33,40	CT1 CT4	CR 524940 CR 528269	1 013	34,90 36,50	23,80 25,40	CT1 CT1	CR 523584 CR 529379		
746	38,10 39,70	27 28,60	CT1 CT4	CR 524853 CR 528270	1 016	36,50 38,10	25,40 27	CT1 CT1	CR 525035 CR 527903		
755	34,90 38,10	23,80 27	CT1 CT1	CR 524217 CR 524218	1 018	54,80	43,70	CT4	CR 530396		
755,70	38,10	27	CT1	CR 524973	1 022	31,80	20,70	CT1	CR 525426		
764	28,60	17,50	CT1	CR 525033	1 029	38,10	27	CT1	CR 528532		
787	31,80	20,70	CT1	CR 525212	1 038	38,10	27	CT1	CR 525633		
800	31,80	20,70	CT1	CR 528210	1 041	38,10	27	CT1	CR 524227		
806	31,80	20,70	CT1	CR 526715	1 045	38,10	27	CT1	CR 525036		
818	31,80	20,70	CT1	CR 525034	1 051	33,40	22,30	CT1	CR 530448		
819,20	31,80	20,70	CT1	CR 524294	1 054	31,80 38,10	20,70 27	CT1 CT1	CR 527474 CR 524228		
822,30	31,80	20,70	CT1	CR 593949	1 064	41,30	30,20	CT4	CR 528272		
825	28,60 31,80	17,50 20,70	CT1 CT1	CR 594785 CR 524367	1 066	63,50	52,40	CT4	CR 528271		
840	31,80	20,70	CT1	CR 526867	1 066,90	38,10	27	CT4	CR 594494		
856	31,80	20,70	CT1	CR 524219	1 080	28,60	17,50	CT1	CR 523133		

Axial clamp seals – CT1 and CT4 – metric dimensions
 d_1 1 101,70 – 4 142 mm

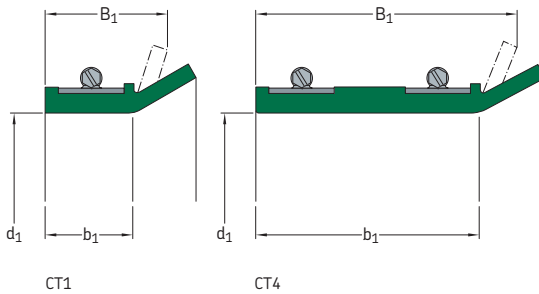

See **table 1, page 469** for application tolerances.

Dimensions			Design	Designation	Dimensions			Design	Designation
Seal seat diameter d_1	Seal fitted width B_1	Seal seat width b_1			Seal seat diameter d_1	Seal fitted width B_1	Seal seat width b_1		
mm			–	–	mm			–	–
1 101,70	31,80	20,70	CT1	CR 524909	1 321	38,10	27	CT1	CR 528927
1 105	38,10	27	CT1	CR 524369	1 346	31,80	20,70	CT1	CR 528526
1 118	31,80	20,70	CT1	CR 524370	1 397	31,80	20,70	CT1	CR 526807
	34,90	23,80	CT1	CR 528415					
	38,10	27	CT1	CR 524229					
	38,10	27	CT1	CR 593180					
	44,50	33,40	CT4	CR 528002					
44,50	33,40	CT4	CR 528273	1 448	31,80	20,70	CT1	CR 528525	
1 140	38,10	27	CT1	CR 522676	1 497,60	41,30	30,20	CT4	CR 594163
	38,10	27	CT1	CR 522677					
	38,10	27	CT1	CR 524231					
	38,10	27	CT1	CR 524371					
	38,10	27	CT1	CR 522828					
1 181	31,80	20,70	CT1	CR 529086	1 613	31,80	20,70	CT1	CR 526808
1 193,80	38,10	27	CT1	CR 527211	1 721	31,80	20,70	CT1	CR 528975
	38,10	27	CT1	CR 525091					
1 206	31,80	27	CT1	CR 526021	1 778	31,80	20,70	CT1	CR 526809
	34,90	23,80	CT1	CR 524230					
	38,10	27	CT1	CR 524230					
1 206,50	30,20	19,10	CT1	CR 530606	1 803	31,80	20,70	CT1	CR 524373
	38,10	27	CT1	CR 522677					
1 210	38,10	27	CT1	CR 522677	1 854	38,10	27	CT1	CR 531456
	38,10	27	CT1	CR 524231					
1 225	38,10	27	CT1	CR 524231	1 924	31,80	20,70	CT1	CR 525092
1 241	38,10	27	CT1	CR 524371					
1 245	31,80	20,70	CT1	CR 522828	1 968	31,80	20,70	CT1	CR 529517
1 270	34,90	23,80	CT1	CR 529129					
1 286	31,80	20,70	CT1	CR 525953	2 540	38,10	27	CT1	CR 522856
1 302	34,90	23,80	CT1	CR 529130					
1 308	31,80	20,70	CT1	CR 524372	2 616	31,80	20,70	CT1	CR 594083
	34,90	23,80	CT1	CR 530661					
	38,10	27	CT1	CR 524232					
					4 142	31,80	20,70	CT1	CR 594682

Axial clamp seals – CT1 and CT4 – inch dimensions

d_1 6.614 – 29.016 in.

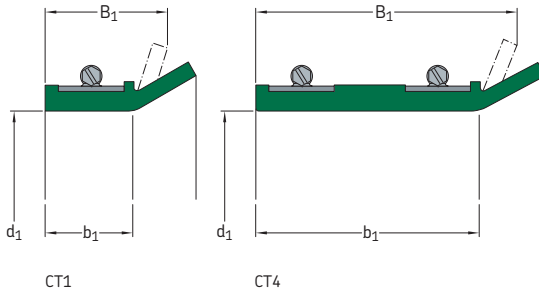

See table 1, page 469 for application tolerances.

Dimensions			Design	Designation	Dimensions			Design	Designation
Seal seat diameter d_1	Seal fitted width B_1	Seal seat width b_1			Seal seat diameter d_1	Seal fitted width B_1	Seal seat width b_1		
in.			–	–	in.		–	–	
6.614	1.126	0.689	CT1	CR 594334	18.504	1.126	0.689	CT1	CR 525708
6.626	1.126	0.689	CT1	CR 529489	18.504	1.252	0.815	CT1	CR 526192
7.008	1.500	1.063	CT1	CR 523586	19.488	1.126	0.689	CT1	CR 594181
7.284	1.181	0.744	CT1	CR 593637	20.000	1.252	0.815	CT1	CR 524587
8.252	1.126	0.689	CT1	CR 527820	20.984	1.260	0.823	CT1	CR 594241
8.622	1.126	0.689	CT1	CR 529490	21.496	1.252	0.815	CT1	CR 524599
8.937	1.126	0.689	CT1	CR 531635	21.496	3.752	3.315	CT4	CR 526741
9.000	1.126	0.689	CT1	CR 524204	21.811	1.252	0.815	CT1	CR 524210
9.000	1.126	0.689	CT1	CR 527819	21.929	1.126	0.689	CT1	CR 524211
9.016	1.142	0.705	CT1	CR 528631	22.008	1.252	0.815	CT1	CR 524347
10.000	1.126	0.689	CT1	CR 524205	22.500	1.252	0.815	CT1	CR 524212
10.000	1.126	0.689	CT1	CR 527806	22.756	1.374	0.937	CT1	CR 524657
10.748	1.126	0.689	CT1	CR 594369	23.386	1.374	0.937	CT1	CR 525627
11.024	1.126	0.689	CT1	CR 524206	23.426	1.126	0.689	CT1	CR 525031
11.024	1.252	0.815	CT1	CR 524928	23.504	1.374	0.937	CT1	CR 524364
11.748	1.126	0.689	CT1	CR 593629	23.622	1.181	0.744	CT1	CR 594431
12.008	1.252	0.815	CT1	CR 524208	23.740	1.252	0.815	CT1	CR 524365
12.008	1.500	1.063	CT1	CR 525582	23.740	1.374	0.937	CT1	CR 523184
12.992	1.126	0.689	CT1	CR 524209	23.740	1.811	1.374	CT4	CR 528651
12.992	1.500	1.063	CT1	CR 523587	23.752	1.374	0.937	CT1	CR 525637
13.811	1.500	1.063	CT1	CR 594110	23.752	1.811	1.374	CT4	CR 528267
14.000	1.500	1.063	CT1	CR 530733	24.252	1.874	1.437	CT4	CR 529276
14.000	1.374	0.937	CT1	CR 593037	24.764	1.252	0.815	CT1	CR 524213
14.961	1.500	1.063	CT1	CR 593171	25.118	1.374	0.937	CT1	CR 524214
15.000	1.126	0.689	CT1	CR 594025	25.787	1.575	1.138	CT4	CR 594784
15.236	1.126	0.689	CT1	CR 594954	25.984	1.374	0.937	CT1	CR 524591
16.142	0.937	0.500	CT1	CR 595110	26.929	1.126	0.689	CT1	CR 524215
16.260	3.500	3.063	CT4	CR 592934	26.929	2.874	2.437	CT4	CR 593604
16.732	1.252	0.815	CT1	CR 523826	27.244	1.374	0.937	CT1	CR 524592
16.732	1.315	0.878	CT1	CR 524815	27.756	1.374	0.937	CT1	CR 524216
17.008	1.500	1.063	CT1	CR 528535	27.756	2.374	1.937	CT4	CR 528268
17.500	1.374	0.937	CT1	CR 525737	27.992	1.252	0.815	CT1	CR 527232
17.520	1.252	0.815	CT1	CR 522679	28.819	1.126	0.689	CT1	CR 525032
17.520	1.374	0.937	CT1	CR 523547	29.016	1.500	1.063	CT1	CR 524940
17.689	3.752	3.315	CT4	CR 528070	29.016	1.752	1.315	CT4	CR 528269

Axial clamp seals – CT1 and CT4 – inch dimensions

d₁ 29.370 – 163.071 in.

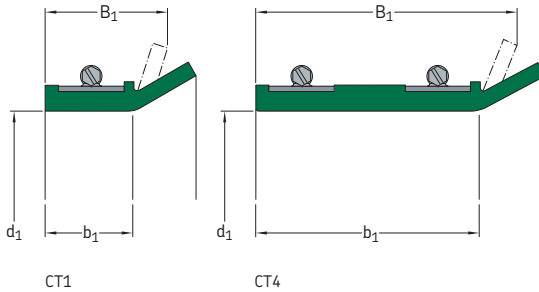

See table 1, page 469 for application tolerances.

Dimensions			Design	Designation	Dimensions			Design	Designation
Seal seat diameter d ₁	Seal fitted width B ₁	Seal seat width b ₁			Seal seat diameter d ₁	Seal fitted width B ₁	Seal seat width b ₁		
in.			–	–	in.			–	–
29.370	1.500	1.063	CT1	CR 524853	39.488	1.126	0.689	CT1	CR 529452
29.370	1.563	1.126	CT4	CR 528270	39.488	1.252	0.815	CT1	CR 526806
29.724	1.374	0.937	CT1	CR 524217	39.882	1.374	0.937	CT1	CR 523584
29.724	1.500	1.063	CT1	CR 524218	39.882	1.437	1.000	CT1	CR 529379
29.752	1.500	1.063	CT1	CR 524973	40.000	1.437	1.000	CT1	CR 525035
30.079	1.126	0.689	CT1	CR 525033	40.000	1.500	1.063	CT1	CR 527903
30.984	1.252	0.815	CT1	CR 525212	40.079	2.156	1.721	CT4	CR 530396
31.496	1.252	0.815	CT1	CR 528210	40.236	1.252	0.815	CT1	CR 525426
31.732	1.252	0.815	CT1	CR 526715	40.512	1.500	1.063	CT1	CR 528532
32.205	1.252	0.815	CT1	CR 525034	40.866	1.500	1.063	CT1	CR 525633
32.252	1.252	0.815	CT1	CR 524294	40.984	1.500	1.063	CT1	CR 524227
32.374	1.252	0.815	CT1	CR 593949	41.142	1.500	1.063	CT1	CR 525036
32.480	1.126	0.689	CT1	CR 594785	41.378	1.315	0.878	CT1	CR 530448
32.480	1.252	0.815	CT1	CR 524367	41.496	1.252	0.815	CT1	CR 527474
33.071	1.252	0.815	CT1	CR 526867	41.496	1.500	1.063	CT1	CR 524228
33.701	1.252	0.815	CT1	CR 524219	41.890	1.626	1.189	CT4	CR 528272
34.488	1.500	1.063	CT1	CR 523063	41.968	2.500	2.063	CT4	CR 528271
35.000	1.252	0.815	CT1	CR 524220	42.004	1.500	1.063	CT4	CR 594494
35.433	1.252	0.815	CT1	CR 524221	42.520	1.126	0.689	CT1	CR 523133
35.512	1.500	1.063	CT1	CR 524222	43.374	1.252	0.815	CT1	CR 524909
35.984	1.126	0.689	CT1	CR 528416	43.504	1.500	1.063	CT1	CR 524369
35.984	1.189	0.752	CT1	CR 524223	44.016	1.252	0.815	CT1	CR 524370
35.984	1.500	1.063	CT1	CR 524224	44.016	1.374	0.937	CT1	CR 528415
36.000	1.126	0.689	CT1	CR 593606	44.016	1.500	1.063	CT1	CR 524229
36.000	1.252	0.815	CT1	CR 530466	44.016	1.500	1.063	CT1	CR 593180
36.575	1.126	0.689	CT1	CR 593285	44.016	1.752	1.315	CT4	CR 528002
36.575	2.961	2.524	CT4	CR 594202	44.016	1.752	1.315	CT4	CR 528273
36.890	1.374	0.937	CT1	CR 523154	44.882	1.500	1.063	CT1	CR 522676
37.008	1.252	0.815	CT1	CR 526246	46.496	1.252	0.815	CT1	CR 529086
37.008	1.500	1.063	CT1	CR 525320	47.000	1.500	1.063	CT1	CR 527211
37.126	1.252	0.815	CT1	CR 524768	47.480	1.252	1.063	CT1	CR 525091
37.244	1.252	0.815	CT1	CR 524368	47.480	1.374	0.937	CT1	CR 526021
37.480	1.252	0.815	CT1	CR 526582	47.480	1.500	1.063	CT1	CR 524230
37.874	1.252	0.815	CT1	CR 524225	47.500	1.189	0.752	CT1	CR 530606
37.992	1.252	0.815	CT1	CR 524226	47.638	1.500	1.063	CT1	CR 522677

Dimensions			Design	Designation
Seal seat diameter d_1	Seal fitted width B_1	Seal seat width b_1		
in.			-	-
48.228	1.500	1.063	CT1	CR 524231
48.858	1.500	1.063	CT1	CR 524371
49.016	1.252	0.815	CT1	CR 522828
50.000	1.374	0.937	CT1	CR 529129
50.630	1.252	0.815	CT1	CR 525953
51.260	1.374	0.937	CT1	CR 529130
51.496	1.252	0.815	CT1	CR 524372
51.496	1.374	0.937	CT1	CR 530661
51.496	1.500	1.063	CT1	CR 524232
52.008	1.500	1.063	CT1	CR 528927
52.992	1.252	0.815	CT1	CR 528526
55.000	1.252	0.815	CT1	CR 526807
57.008	1.252	0.815	CT1	CR 528525
58.606	1.626	1.189	CT4	CR 594163
63.504	1.252	0.815	CT1	CR 526808
67.756	1.252	0.815	CT1	CR 528975
70.000	1.252	0.815	CT1	CR 526809
70.984	1.252	0.815	CT1	CR 524373
72.992	1.500	1.063	CT1	CR 531456
75.748	1.252	0.815	CT1	CR 525092
77.480	1.252	0.815	CT1	CR 529517
100.00	1.500	1.063	CT1	CR 522856
102.992	1.252	0.815	CT1	CR 594083
163.071	1.252	0.815	CT1	CR 594082
163.071	1.252	0.815	CT1	CR 594082

Product index

Design	Product group	Product table	Page
CRS1	Radial shaft seal	2.6	171
CRSA1	Radial shaft seal	2.6	171
CRSH1	Radial shaft seal	2.6	171
CRSHA1	Radial shaft seal	2.6	172
CRW1	Radial shaft seal	2.2	101
CRW5	Radial shaft seal	2.3	157
CRWA1	Radial shaft seal	2.2	102
CRWA5	Radial shaft seal	2.3	157
CRWH1	Radial shaft seal	2.2	109
CRWHA1	Radial shaft seal	2.2	109
CT1	Axial clamp seal	8.1	472
CT4	Axial clamp seal	8.1	472
DL	Radial shaft seal		178*
DLA	Radial shaft seal		178*
HDDF	Metal face seal	6.1	388
HDL	Radial shaft seal	2.11	230
HDS1	Radial shaft seal	2.12	246
HDS1K	Radial shaft seal	2.13	262
HDS2K	Radial shaft seal	2.14	264
HDS2	Radial shaft seal	2.12	246
HDS3	Radial shaft seal	2.12	246
HDS7	Radial shaft seal	2.9	220
HDS7K	Radial shaft seal	2.10	226
HDSA1	Radial shaft seal	2.16	268
HDSA2	Radial shaft seal	2.16	268
HDSB1	Radial shaft seal	2.16	268
HDSB2	Radial shaft seal	2.16	268
HDSC1	Radial shaft seal	2.16	268
HDSC2	Radial shaft seal	2.16	270
HDSD1	Radial shaft seal	2.18	276
HDSD2	Radial shaft seal	2.18	276
HDSE1	Radial shaft seal	2.17	274
HDSE2	Radial shaft seal	2.18	276
HDSF1	Radial shaft seal	2.15	267
HDSF2	Radial shaft seal	2.15	266
HDSF7	Radial shaft seal	2.15	266
HDSH7	Radial shaft seal	2.15	266
HDW1	Radial shaft seal	2.4	161
HM1	Radial shaft seal	2.7	183
HM102	Radial shaft seal	2.7	183
HM11	Radial shaft seal	2.7	191
HM12	Radial shaft seal	2.7	195
HM14	Radial shaft seal	2.7	183
HM18	Radial shaft seal	2.7	189
HM21	Radial shaft seal	2.7	187
HM3	Radial shaft seal	2.7	183
HM4	Radial shaft seal	2.7	183
HM8	Radial shaft seal	2.7	186
HMA10	Radial shaft seal	2.7	183
HMA101	Radial shaft seal	2.7	185

* Product table not available. Contact SKF for more information.

Design	Product group	Product table	Page
HMA11	Radial shaft seal	2.7	190
HMA14	Radial shaft seal	2.7	186
HMA21	Radial shaft seal	2.7	195
HMA22	Radial shaft seal	2.7	185
HMA6	Radial shaft seal	2.7	187
HMA76	Radial shaft seal	2.7	184
HMA8	Radial shaft seal	2.7	185
HMA85	Radial shaft seal	2.7	185
HMA94	Radial shaft seal	2.7	193
HMA96	Radial shaft seal	2.7	195
HMS4	Radial shaft seal	2.5	163
HMS5	Radial shaft seal	2.1	94
HMSA10	Radial shaft seal	2.1	94
HMSA7	Radial shaft seal	2.5	163
HS4	Radial shaft seal	2.25	306
HS5	Radial shaft seal	2.25	306
HS6	Radial shaft seal	2.26	310
HS7	Radial shaft seal	2.26	310
HS8	Radial shaft seal	2.26	310
HSF1	Radial shaft seal	2.20	280
HSF2	Radial shaft seal	2.21	294
HSF3	Radial shaft seal	2.22	296
HSF4	Radial shaft seal	2.23	302
HSF5	Radial shaft seal	2.20	280
HSF6	Radial shaft seal	2.21	294
HSF7	Radial shaft seal	2.22	296
HSF8	Radial shaft seal	2.23	302
HSF9	Radial shaft seal	2.24	304
LDSLV3	Wear sleeve	4.2	364
LDSLV4	Wear sleeve	4.2	364
MUD1	Cassette seal		325*
MUD2	Cassette seal		325*
MUD3	Cassette seal		325*
MUD4	Cassette seal		325*
MUD5	Cassette seal		325*
MUD6	Cassette seal		325*
MUD7	Cassette seal		325*
MVR1	V-ring seal	7.3	462
MVR2	V-ring seal	7.4	464
SBF	Radial shaft seal	2.19	278
SKF SPEEDI-SLEEVE	Wear sleeve	4.1	338
SL	Radial shaft seal		178*
SLA	Radial shaft seal		178*
SLS	Radial shaft seal		178*
SLX	Radial shaft seal		178*
TL1	Radial shaft seal	2.7	194
TL4	Radial shaft seal	2.7	194
TL5	Radial shaft seal	2.7	194
TL6	Radial shaft seal	2.7	192
TL7	Radial shaft seal	2.7	191
TL8	Radial shaft seal	2.7	190
TP	Track pin seal	5.1	380
TPM	Track pin seal	5.1	380
VR1	V-ring seal	7.1	404
VR2	V-ring seal	7.1	404
VR3	V-ring seal	7.1	407
VR4	V-ring seal	7.1	409
VR5	V-ring seal	7.1	411
VR6	V-ring seal	7.1	409
VA	V-ring seal	7.2	432
VE	V-ring seal	7.2	437
VS	V-ring seal	7.2	432
VL	V-ring seal	7.2	435
VRM	V-ring seal	7.2	439
VRME	V-ring seal	7.2	437

* Product table not available. Contact SKF for more information.



Design	Product group	Product table	Page
X1	Radial shaft seal	2.8	197
X12	Radial shaft seal	2.8	197
X13	Radial shaft seal	2.8	197
X14	Radial shaft seal	2.8	198
X15	Radial shaft seal	2.8	197
X2	Radial shaft seal	2.8	197
X4	Radial shaft seal	2.8	197
XH15	Radial shaft seal	2.8	197
YNSLE	Radial shaft seal		178*
YSL	Radial shaft seal		178*
YSLE	Radial shaft seal		178*

