



SKF heavy-duty spherical plain bearings

Steel/steel spherical plain bearings
with LS heavy-duty seals

- Increased service life
- Lower system costs
- Minimal maintenance



The SKF heavy-duty system

A set of strong elements

The SKF heavy-duty system for spherical plain bearings is a modular solution characterized by the following:

- tough steel/steel spherical plain bearings
- multi-groove system
- newly developed seals
- high-performance lubricants

Each one of these elements provides a benefit, which when compounded, can provide the following benefits:

- minimize maintenance
- create more robust bearing arrangements with fewer parts
- improve performance substantially.

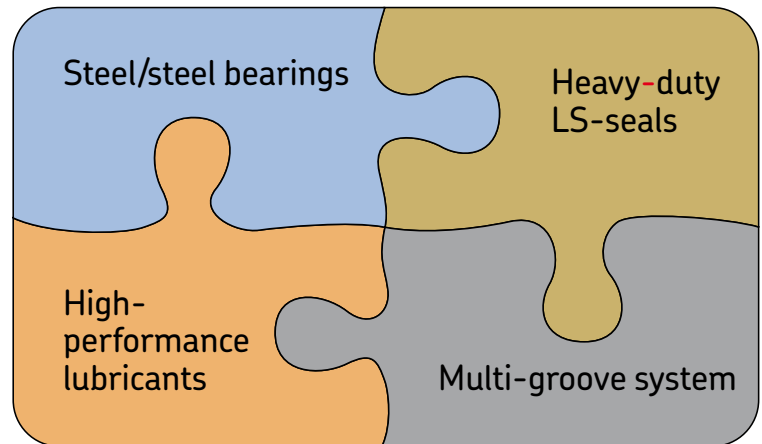

A combination of these elements makes the SKF heavy-duty system an excellent solution for applications that must operate reliably in extreme environments.



The heavy-duty system

Steel/steel bearings

For heavy-duty applications, the bearing selection process is extremely important. Typically, the bearings in these types of applications must accommodate:

- heavy alternating loads
- shock loads
- heavy static loads

Steel/steel radial spherical plain bearings (→ **fig. 1**) are an excellent choice for these applications, because the high strength of the sliding contact surfaces provides superior performance under these load conditions.

The multi-groove system

The multi-groove system optimizes both the effectiveness of the lubricant and the lubrication conditions within the bearing. Benefits of the multi-groove system include:

- more grease inside the bearing
- better grease distribution
- grease remains fresh longer
- bearings can be relubricated even when fully loaded

The multi-groove system can improve the bearing service life, depending on the oscillating angle – the smaller the oscillating angle, the higher the positive effect on bearing life (even up to 200%) (→ **diagram 1**).

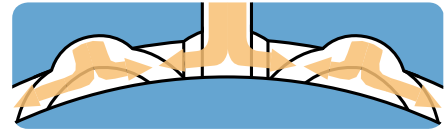

The multi-groove system promotes a better lubrication condition inside the bearing

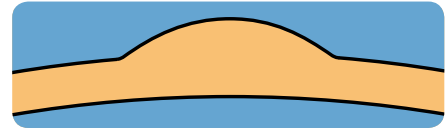

The multi-groove system provides a reservoir for grease inside the bearing, even under load conditions

SKF heavy-duty spherical plain bearing with the multi-groove system, for improved lubrication, and LS seals

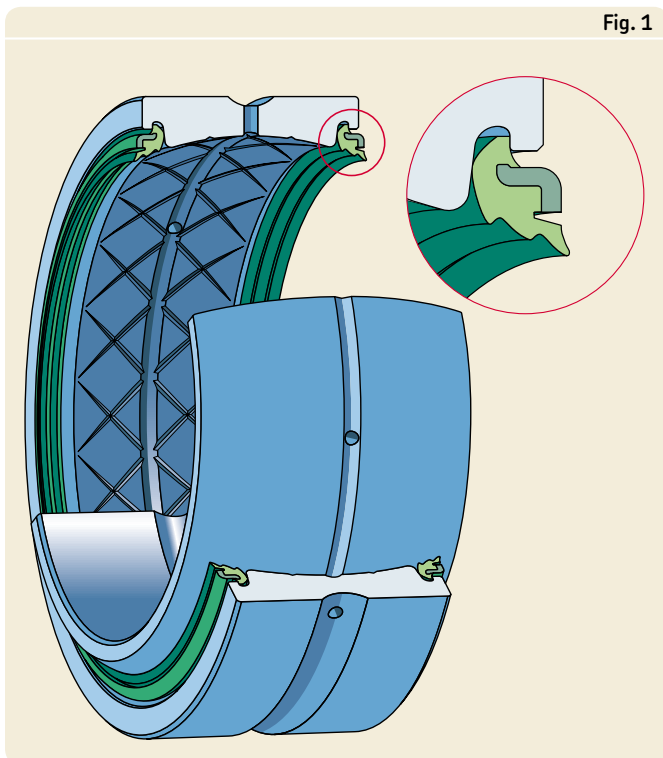
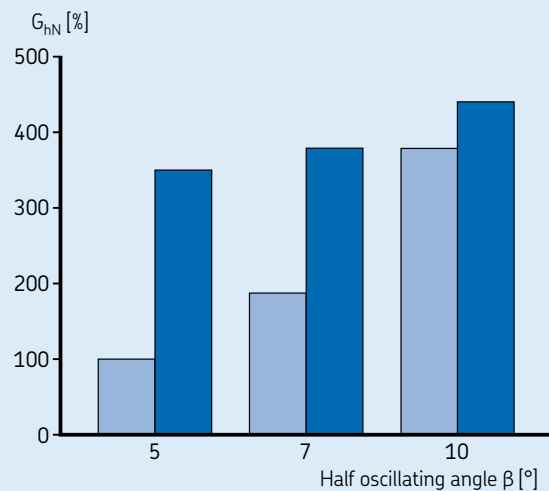

Fig. 1

Diagram 1

Influence of the multi-groove system on bearing life G_{hN} depending on the oscillating angle



■ Conventional system
■ Multi-groove system

The LS heavy-duty seal

To perform well for long periods under harsh operating conditions, the seal must be located firmly and protected from damage. To achieve this, the LS heavy-duty seal has been reinforced with a steel insert (→ **fig. 2**). This insert increases retention forces considerably (→ **diagram 2**) and closely covers the seal lip, protecting it from larger sized contaminants.

Designed for harsh environments, the new LS heavy-duty seal was developed for long service life in highly contaminated environments. The result is a three-lip seal specially designed for:

- dimensional stability
- optimum stiffness

These characteristics provide a very reliable contact between the seal lips and the inner ring. The design of the seal lips creates a safe opening from the inside-out to provide a number of advantages including:

- virtually eliminates the ingress of contaminants into the bearing (→ **fig. 3**)
- enables excess grease to escape from the bearing during relubrication (→ **fig. 4**)

These advantages can significantly improve bearing service life. Also, relubrication intervals can be extended, because there are fewer contaminants inside the bearing that need to be expelled.

In tests under severe operating conditions (→ **diagram 3**), the service life¹⁾ of an LS heavy-duty seal was shown to last three times longer than standard seals. Made of long-lasting, oil and wear-resistant acrylonitrile-butadiene rubber (NBR), these seals are suitable for operating temperatures between -25 and $+120$ °C (-15 and $+250$ °F) and up to $+130$ °C ($+265$ °F) for short periods. NBR is highly wear resistant and maintains its shape to provide excellent performance characteristics. Its resistance to aging further extends the service life of the seal.

¹⁾ Time until the ingress of contaminants under sludge test conditions.

Diagram 2

Test results: seal retention force

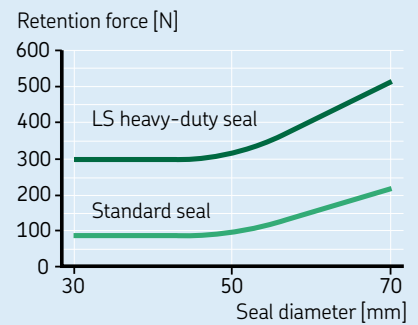
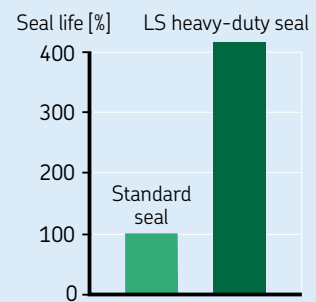

Diagram 3

Test results: seal life



A steel insert protects the seal lips from damage



Three seal lips keep contaminants out

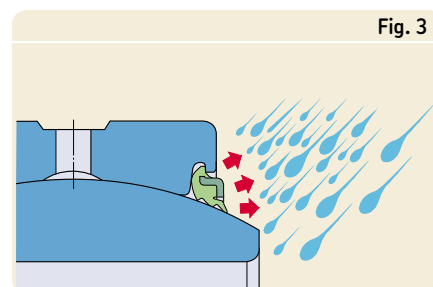

Designed so that grease can escape, the seal will not eject during relubrication

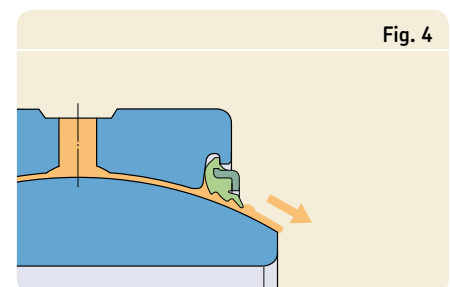

Lubrication

For the SKF heavy-duty spherical plain bearing system, SKF recommends one of following greases (→ **table 1**):

- high performance LGHB 2 grease
- biodegradable LGGB 2 grease

The grease you choose depends on the application and the operating conditions.

For standard applications, SKF recommends using LGHB 2 grease. This grease, which has been proven to have superior mechanical stability, also has excellent anti-oxidation and anti-corrosion properties. For these bearings, LGHB 2 grease provides a significant increase in bearing service life (→ **diagram 4**) and can further extend maintenance intervals.

LGGB 2 grease, the SKF “green grease”, is the first biodegradable grease suitable for heavily loaded and demanding bearing applications, as it exhibits similar performance characteristics as an EP grease, such as SKF LGEP 2 grease (→ **diagram 4**).

Even if the service life is satisfactory, LGGB 2 “green grease” should be considered as an alternative for relubrication in applications where pollution of the environment is a concern.

To switch to one of these greases for relubrication of the bearings in an existing machine, check that the two greases are compatible.

For applications with very specific requirements or unique operating conditions, such as chemical exposure or permanent, small oscillations, other special greases may be required.

For additional information about greases, contact the SKF application engineering service.

Benefits of the SKF heavy-duty system

Heavy-duty steel/steel spherical plain bearings with an LS heavy-duty seal were developed for applications that must operate reliably in highly contaminated environments. Typical applications where the SKF heavy-duty system is used:

- agricultural and forestry equipment
- construction and earthmoving equipment
- mining and conveying equipment
- material handling machinery
- steel mills
- railway vehicles
- linkages and rod ends
- other similar applications

Whether in development, design, production or operation, the SKF heavy-duty spherical plain bearing system provides a number of benefits:

- **More compact sealing arrangements with fewer components**
Due to the high performance characteristics of the LS triple-lip seal and protective steel insert, external sealing arrangements can be simplified or omitted.
- **Fewer surfaces to be finished**
Because SKF spherical plain bearings have integral seals, there is no need to machine or grind a seal counterface on adjacent components.
- **Improved reliability under severe operating conditions**
High-performance greases, combined with the highly engineered design of the LS heavy-duty seal, provide extended bearing service life.
- **Reduced downtime**
The multi-groove system and highly-efficient seal extend the service life of the grease, enabling extended relubrication intervals.
- **Reduced unplanned downtime**
In particularly difficult applications where high levels of contamination are the cause of premature bearing failure, the heavy-duty system can significantly reduce unplanned downtime.

Table 1

Technical data of SKF greases for heavy-duty spherical plain bearing systems

Property	Grease LGHB 2	LGGB 2	LGEP 2
Base oil	Mineral oil	Synthetic ester oil	Mineral oil
Thickener	Complex calcium sulphonate	Lithium-calcium soap	Lithium soap
Colour	Brown	White	Light brown
NLGI consistency class	2	2	2
Base oil viscosity, mm²/s at 40 °C at 100 °C	400–450 26,5	110 13	200 16
Temperature range, °C (°F)	–20 to +150 (–4 to +300)	–40 to +120 (–40 to +250)	–20 to +110 (–4 to +230)
Dropping point, °C (°F)	≥ 220 (≥ 430)	≥ 170 (≥ 340)	≥ 180 (≥ 355)

Diagram 4

Influence of SKF greases on bearing life

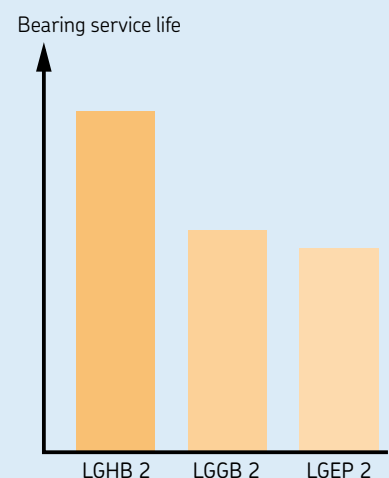

- **Upgraded existing machines for more demanding applications**

The boundary dimensions of SKF spherical plain bearings are in accordance with ISO and ANSI standards and are dimensionally interchangeable with standard products that meet those specifications.

- **Protect the environment**

SKF “green grease” LGGB 2 helps to reduce the environmental impact. This highly effective grease is biodegradable and provides similar, and in some cases better, performance than an EP grease.

Reduce system costs by 30%

For example, compare two rocking lever designs. **Fig. 5** shows a conventional arrangement with an external sealing arrangement. **Fig. 6** shows an arrangement using an SKF spherical plain bearing with integral LS heavy-duty seals. With the SKF heavy-duty system, designers can save up to 30% of the system cost (→ **diagram 5**), while maintaining the same performance level.

The potential for similar savings in other designs depends on the specific requirements.

The assortment

Bearings

Spherical plain bearings in the GE, GEH, GEM and GEZ series are available with heavy-duty LS seals.

The multi-groove system is standard for metric bearings with an outside diameter ≥ 150 mm.

SKF steel/steel radial spherical plain bearings are made of high grade carbon chromium steel that has been hardened, ground and phosphated. The sliding surfaces are treated with a running-in lubricant but have to be lubricated before use. The outer ring is intentionally fractured at a given point, so that it can be sprung apart to enable the inner ring to be inserted. The bearings are non-separable.

Greases

SKF recommends LGHB 2 and LGGB 2 greases for use with the SKF heavy-duty system. These greases are available in the following pack sizes:

- 125 ml cartridge unit for the SKF SYSTEM 24 automatic lubricator
- 420 ml cartridge for grease guns
- 5 kg and 18 kg cans
- 50 kg and 180 kg drums

Additional information about SKF’s wide assortment of lubricants, lubrication devices, and tools for mounting and dismounting can be found in the SKF catalogue MP3000 “SKF Maintenance and Lubrication Products”.

Diagram 5

Cost comparison

Cost, [%]

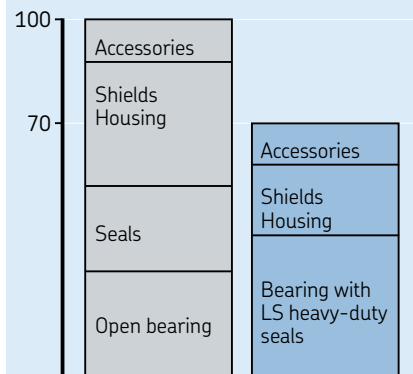

Rocking lever with a conventional bearing arrangement with external seals

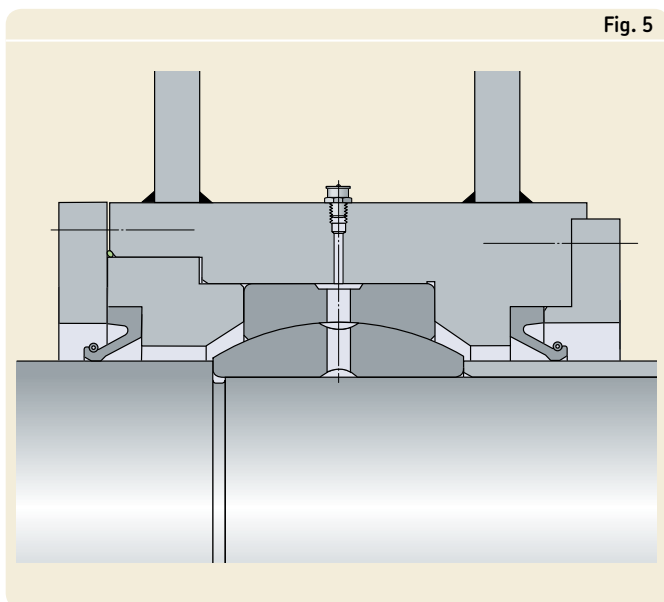

Fig. 5

Rocking lever with an SKF spherical plain bearing with integrated LS heavy-duty seals

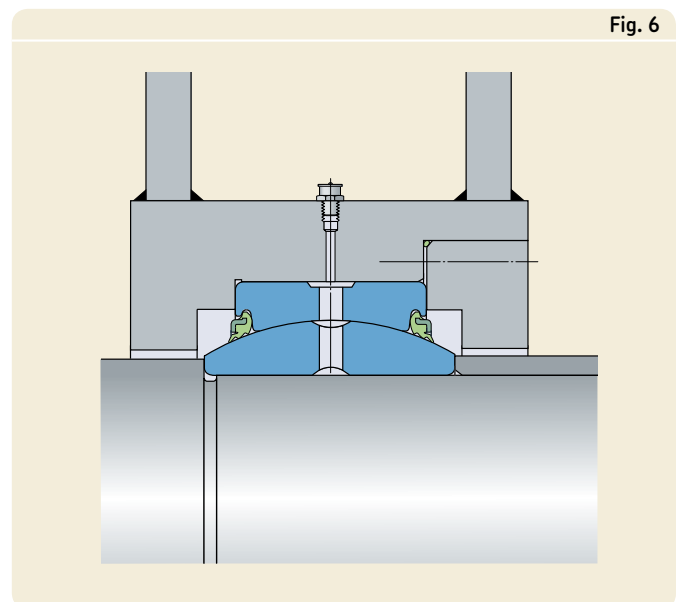

Fig. 6

Bearing data – general Tolerances

Dimensions

Boundary dimensions of metric spherical plain bearings in the GE .. ES(L)-2LS and GEH .. ES(L)-2LS series are in accordance with ISO 12240-1. Bearings in the GEM .. ESL-2LS series have a non-standard inner ring, but otherwise are in accordance with ISO 12240-1. Boundary dimensions of inch spherical plain bearings in the GEZ .. ESL-2LS series are in accordance with ANSI/ABMA Std. 22.2-1988.

SKF metric radial spherical plain bearings are manufactured to tolerances in accordance with ISO 12240-1. SKF inch radial spherical plain bearings are manufactured to tolerances in accordance with ANSI/ABMA Std. 22.2-1988.

Internal clearance

The radial internal clearance values are listed in **table 2**. The bearings are manufactured as standard with Normal radial internal clearance. For bearings with a C2 or C3 radial internal clearance, contact SKF for availability.

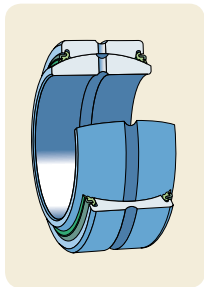

GE .. ESL-2LS

Metric radial spherical plain bearings with an annular groove and lubrication holes in the inner and outer rings and the multi-groove system. Range: 20 to 90 mm bore.

GE .. ES-2LS

Metric radial spherical plain bearings with an annular groove and lubrication holes in the inner and outer rings, multi-groove system. Range: 100 to 300 mm bore.

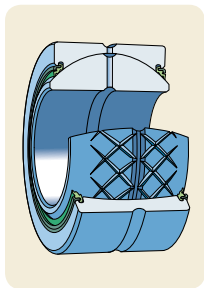

GEZ .. ESL-2LS

Inch size radial spherical plain bearings with an annular groove and lubrication holes in the inner and outer rings, multi-groove system. Range: 1 to 6 inch bore.

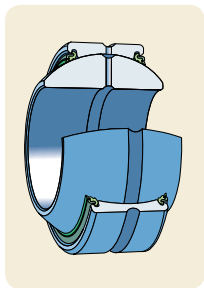

GEH .. ESL-2LS

Metric radial spherical plain bearings, as GE .. ESL-2LS, but with wider inner ring and larger outside diameter. Range: 20 to 120 mm bore.

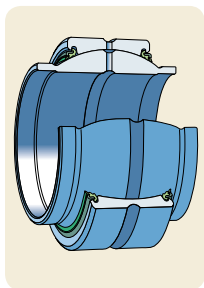

GEM .. ESL-2LS

Metric radial spherical plain bearings, as GE .. ESL-2LS, but with a cylindrical extension on both sides of the inner ring. Range: 20 to 80 mm bore.

Table 2

Radial internal clearance of steel/steel spherical plain bearings

Bore diameter d		Radial internal clearance ¹⁾					
		C2		Normal		C3	
over	incl.	min	max	min	max	min	max
mm/in		µm					

Metric bearings

12	20	10	40	40	82	82	124
20	35	12	50	50	100	100	150
35	60	15	60	60	120	120	180
60	90	18	72	72	142	142	212
90	140	18	85	85	165	165	245
140	200	18	100	100	192	192	284
200	240	18	110	110	214	214	318
240	300	18	125	125	239	239	353

Inch bearings

5/8	2	25	105	80	180	180	260
2	3	30	130	100	200	200	300
3	6	40	160	130	230	230	350

¹⁾ Bearings in the GEH series with a bore d = 20, 35, 60 and 90 mm have a radial internal clearance corresponding to the values quoted for the next larger diameter range.

Steel/steel spherical plain bearings with LS heavy-duty seals and the multi-groove system, metric sizes

d 20 – 300 mm

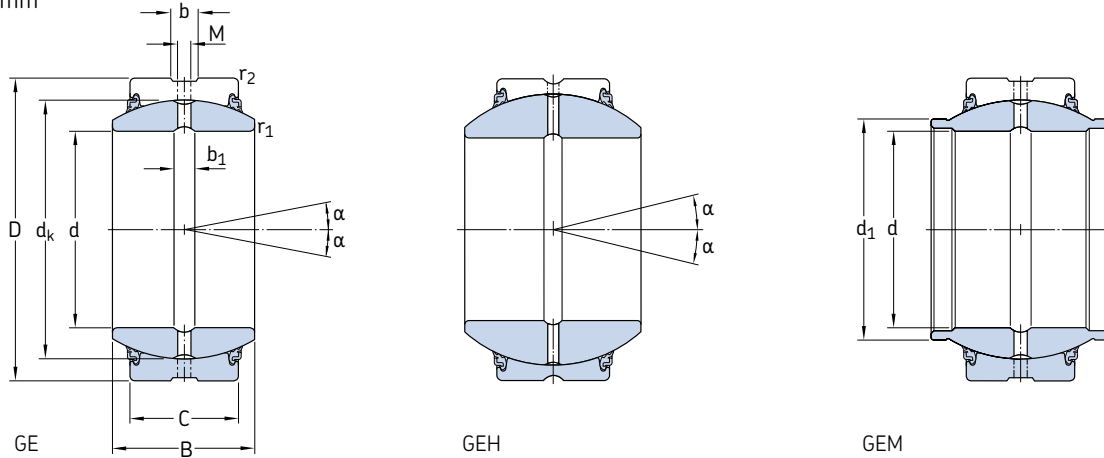

Dimensions												Basic load ratings		Mass	Designation
d	D	B	C	dk	d ₁	b	b ₁	M	r ₁ min	r ₂ min	α	dyn. C	stat. C ₀		
mm												deg.	kN	kg	-
20	35	16	12	29	-	146	0,065	2	0,3	0,3	9	30	146	0,065	GE 20 ESL-2LS
	35	24	12	29	24	3,1	3,1	2	0,3	0,3	6	30	146	0,073	GEM 20 ESL-2LS
	42	25	16	35,5	-	240	0,16	2	0,3	0,6	17	48	240	0,16	GEH 20 ESL-2LS
25	42	20	16	35,5	-	3,1	3,1	2	0,6	0,6	7	48	240	0,12	GE 25 ESL-2LS
	42	29	16	35,5	29	3,1	3,1	2	0,3	0,6	4	48	240	0,13	GEM 25 ESL-2LS
	47	28	18	40,7	-	3,1	3,1	2	0,6	0,6	17	62	310	0,20	GEH 25 ESL-2LS
30	47	22	18	40,7	-	3,1	3,1	2	0,6	0,6	6	62	310	0,16	GE 30 ESL-2LS
	47	30	18	40,7	34	3,1	3,1	2	0,3	0,6	4	62	310	0,17	GEM 30 ESL-2LS
	55	32	20	47	-	3,9	3,9	2,5	0,6	1	17	80	400	0,35	GEH 30 ESL-2LS
35	55	25	20	47	-	3,9	3,9	2,5	0,6	1	6	80	400	0,23	GE 35 ESL-2LS
	55	35	20	47	40	3,9	3,9	2,5	0,6	1	4	80	400	0,25	GEM 35 ESL-2LS
	62	35	22	53	-	3,9	3,9	2,5	0,6	1	15	100	500	0,47	GEH 35 ESL-2LS
40	62	28	22	53	-	3,9	3,9	2,5	0,6	1	6	100	500	0,32	GE 40 ESL-2LS
	62	38	22	53	45	3,9	3,9	2,5	0,6	1	4	100	500	0,35	GEM 40 ESL-2LS
	68	40	25	60	-	4,6	4,6	3	0,6	1	17	127	640	0,61	GEH 40 ESL-2LS
45	68	32	25	60	-	4,6	4,6	3	0,6	1	7	127	640	0,46	GE 45 ESL-2LS
	68	40	25	60	52	4,6	4,6	3	0,6	1	4	127	640	0,49	GEM 45 ESL-2LS
	75	43	28	66	-	4,6	4,6	3	0,6	1	14	156	780	0,80	GEH 45 ESL-2LS
50	75	35	28	66	-	4,6	4,6	3	0,6	1	6	156	780	0,56	GE 50 ESL-2LS
	75	43	28	66	57	4,6	4,6	3	0,6	1	4	156	780	0,60	GEM 50 ESL-2LS
	90	56	36	80	-	6,2	6,2	4	0,6	1	17	245	1 220	1,60	GEH 50 ESL-2LS
60	90	44	36	80	-	6,2	6,2	4	1	1	6	245	1 220	1,10	GE 60 ESL-2LS
	90	54	36	80	68	6,2	6,2	4	0,6	1	3	245	1 220	1,15	GEM 60 ESL-2LS
	105	63	40	92	-	7,7	7,7	4	1	1	17	315	1 560	2,40	GEH 60 ESL-2LS
70	105	49	40	92	-	7,7	7,7	4	1	1	6	315	1 560	1,55	GE 70 ESL-2LS
	105	65	40	92	78	7,7	7,7	4	0,6	1	4	315	1 560	1,65	GEM 70 ESL-2LS
	120	70	45	105	-	7,7	7,7	4	1	1	16	400	2 000	3,40	GEH 70 ESL-2LS
80	120	55	45	105	-	7,7	7,7	4	1	1	5	400	2 000	2,30	GE 80 ESL-2LS
	120	74	45	105	90	7,7	7,7	4	0,6	1	4	400	2 000	2,50	GEM 80 ESL-2LS
	130	75	50	115	-	9,5	9,5	5	1	1	14	490	2 450	4,10	GEH 80 ESL-2LS
90	130	60	50	115	-	9,5	9,5	5	1	1	5	490	2 450	2,75	GE 90 ESL-2LS
	150	85	55	130	-	11,3	11,3	5	1	1	15	610	3 050	6,30	GEH 90 ES-2LS
100	150	70	55	130	-	11,3	11,3	5	1	1	6	610	3 050	4,40	GE 100 ES-2LS
	160	85	55	140	-	11,5	11,5	5	1	1	13	655	3 250	6,80	GEH 100 ES-2LS
110	160	70	55	140	-	11,5	11,5	5	1	1	6	655	3 250	4,80	GE 110 ES-2LS
	180	100	70	160	-	13,5	13,5	6	1	1	12	950	4 750	11,0	GEH 110 ES-2LS

Dimensions											Basic load ratings		Mass	Designation
d	D	B	C	d _k	b	b ₁	M	r ₁ min	r ₂ min	α	dyn. C	stat. C ₀		
mm											deg.	kN	kg	–
120	180	85	70	160	13,5	13,5	6	1	1	6	950	4 750	8,25	GE 120 ES-2LS
	210	115	70	180	13,5	13,5	6	1	1	16	1 080	5 400	15,0	GEH 120 ES-2LS
140	210	90	70	180	13,5	13,5	6	1	1	7	1 080	5 400	11,0	GE 140 ES-2LS
160	230	105	80	200	13,5	13,5	6	1	1	8	1 370	6 800	14,0	GE 160 ES-2LS
180	260	105	80	225	13,5	13,5	6	1,1	1,1	6	1 530	7 650	18,5	GE 180 ES-2LS
200	290	130	100	250	15,5	15,5	7	1,1	1,1	7	2 120	10 600	28,0	GE 200 ES-2LS
220	320	135	100	275	15,5	15,5	7	1,1	1,1	8	2 320	11 600	35,5	GE 220 ES-2LS
240	340	140	100	300	15,5	15,5	7	1,1	1,1	8	2 550	12 700	40,0	GE 240 ES-2LS
260	370	150	110	325	15,5	15,5	7	1,1	1,1	7	3 050	15 300	51,5	GE 260 ES-2LS
280	400	155	120	350	15,5	15,5	7	1,1	1,1	6	3 550	18 000	65,0	GE 280 ES-2LS
300	430	165	120	375	15,5	15,5	7	1,1	1,1	7	3 800	19 000	78,5	GE 300 ES-2LS

¹⁾ Metric heavy-duty bearings with the multi-groove system and an outside diameter < 150 mm have the designation series GE .. ESL. Metric heavy-duty bearings with the multi-groove system and an outside diameter ≥ 150 mm have the series designation GE .. ES instead, as the multi-groove system is standard.

Steel/steel spherical plain bearings with LS heavy-duty seals and the multi-groove system, inch sizes

d 1 – 6 inch
25,4 – 152,4 mm

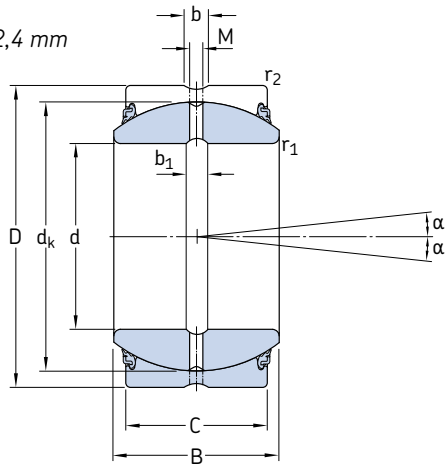

Dimensions											Basic load ratings		Mass	Designation
d	D	B	C	dk	b	b ₁	M	r ₁ min	r ₂ min	α	dyn. C	stat. C ₀		
inch/mm											deg.	kN	kg	–
1.0000 25,4	1.6250 41,275	0.8750 22,225	0.7500 19,05	1.437 36,5	0.126 3,2	0.118 3	0.098 2,5	0.012 0,3	0.039 1	6	56	166	0,12	GEZ 100 ESL-2LS
1.2500 31,75	2.0000 50,800	1.0930 27,762	0.9370 23,8	1.795 45,593	0.189 4,8	0.197 5	0.158 4	0.024 0,6	0.039 1	6	86,5	260	0,23	GEZ 104 ESL-2LS
1.3750 34,925	2.1875 55,563	1.1870 30,150	1.0310 26,187	1.937 49,2	0.189 4,8	0.197 5	0.158 4	0.024 0,6	0.039 1	5	104	310	0,35	GEZ 106 ESL-2LS
1.5000 38,1	2.4375 61,913	1.3120 33,325	1.1250 28,575	2.155 54,737	0.189 4,8	0.197 5	0.158 4	0.024 0,6	0.039 1	6	125	375	0,42	GEZ 108 ESL-2LS
1.7500 44,45	2.8125 71,438	1.5310 38,887	1.3120 33,325	2.515 63,881	0.189 4,8	0.197 5	0.158 4	0.024 0,6	0.039 1	6	170	510	0,64	GEZ 112 ESL-2LS
2.0000 50,8	3.1875 80,963	1.7500 44,450	1.5000 38,1	2.875 73,025	0.189 4,8	0.197 5	0.158 4	0.024 0,6	0.039 1	6	224	670	0,93	GEZ 200 ESL-2LS
2.2500 57,15	3.5625 90,488	1.9690 50,013	1.6870 42,85	3.235 82,169	0.224 5,7	0.197 5	0.158 4	0.024 0,6	0.039 1	6	280	850	1,3	GEZ 204 ESL-2LS
2.5000 63,5	3.9375 100,013	2.1870 55,550	1.8750 47,625	3.590 91,186	0.354 9	0.315 8	0.256 6,5	0.024 0,6	0.039 1	6	345	1 040	1,85	GEZ 208 ESL-2LS
2.7500 69,850	4.3750 111,125	2.4060 61,112	2.0620 52,375	3.950 100,33	0.354 9	0.315 8	0.256 6,5	0.024 0,6	0.039 1	6	425	1 270	2,4	GEZ 212 ESL-2LS
3.0000 76,2	4.7500 120,65	2.6250 66,675	2.2500 57,15	4.312 109,525	0.354 9	0.315 8	0.256 6,5	0.024 0,6	0.039 1	6	500	1 500	3,1	GEZ 300 ESL-2LS
3.2500 82,55	5.1250 130,175	2.8440 72,238	2.4370 61,9	4.675 118,745	0.366 9,3	0.315 8	0.256 6,5	0.024 0,6	0.039 1	6	585	1 760	3,8	GEZ 304 ESL-2LS
3.5000 88,9	5.5000 139,700	3.0620 77,775	2.6250 66,675	5.040 128,016	0.413 10,5	0.315 8	0.256 6,5	0.024 0,6	0.039 1	6	680	2 040	4,8	GEZ 308 ESL-2LS
3.7500 95,25	5.8750 149,225	3.2810 83,337	2.8120 71,425	5.390 136,906	0.413 10,5	0.315 8	0.256 6,5	0.024 0,6	0.039 1	6	780	2 360	5,8	GEZ 312 ESL-2LS
4.0000 101,6	6.2500 158,750	3.5000 88,900	3.0000 76,2	5.750 146,05	0.413 10,5	0.394 10	0.315 8	0.024 0,6	0.039 1	6	900	2 650	7,0	GEZ 400 ESL-2LS
4.5000 114,3	7.0000 177,800	3.9370 100,000	3.3750 85,725	6.475 164,465	0.433 11	0.394 10	0.315 8	0.039 1	0.043 1,1	6	1 120	3 400	9,8	GEZ 408 ESL-2LS
4.7500 120,65	7.3750 187,325	4.1560 105,562	3.5620 90,475	6.825 173,355	0.433 11	0.394 10	0.315 8	0.039 1	0.043 1,1	6	1 250	3 750	11,5	GEZ 412 ESL-2LS

Dimensions											Basic load ratings		Mass	Designation
d	D	B	C	d _k	b -	b ₁ -	M -	r ₁ min	r ₂ min	α	dyn. C	stat. C ₀		
inch/mm										deg.	kN	kg	-	
5.0000 127	7.7500 196,850	4.3750 111,125	3.7500 95,25	7.190 182,626	0.433 11	0.394 10	0.315 8	0.039 1	0.043 1,1	6	1 400	4 150	13,5	GEZ 500 ESL-2LS
6.0000 152,4	8.7500 222,250	4.7500 120,650	4.1250 104,775	8.156 207,162	0.591 15	0.433 11	0.315 8	0.039 1	0.043 1,1	5	1 730	5 200	17,5	GEZ 600 ESL-2LS

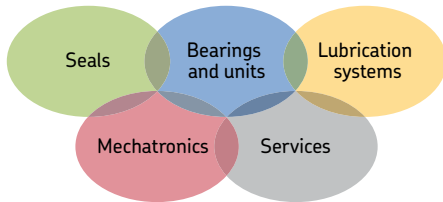

The Power of Knowledge Engineering

Drawing on five areas of competence and application-specific expertise amassed over more than 100 years, SKF brings innovative solutions to OEMs and production facilities in every major industry worldwide. These five competence areas include bearings and units, seals, lubrication systems, mechatronics (combining mechanics and electronics into intelligent systems), and a wide range of services, from 3-D computer modelling to advanced condition monitoring and reliability and asset management systems. A global presence provides SKF customers uniform quality standards and worldwide product availability.

© SKF and SYSTEM 24 are registered trademarks of the SKF Group.

© SKF Group 2008

The contents of this publication are the copyright of the publisher and may not be reproduced (even extracts) unless written permission is granted. Every care has been taken to ensure the accuracy of the information contained in this publication but no liability can be accepted for any loss or damage whether direct, indirect or consequential arising out of the use of the information contained herein.

Publication **6476 EN** · November 2008

This publication supersedes publication 5141 E.

Printed in Sweden on environmentally friendly paper.

