

# SKF FX Keyless Bushings





The SKF brand now stands for more than ever before, and means more to you as a valued customer.

While SKF maintains its leadership as a high-quality bearing manufacturer throughout the world, new dimensions in technical advances, product support and services have evolved SKF into a truly solutions-oriented supplier, creating greater value for customers.

These solutions enable customers to improve productivity, not only with breakthrough application-specific products, but also through leading-edge design simulation tools and consultancy services, plant asset efficiency maintenance programmes, and the industry's most advanced supply management techniques.

The SKF brand still stands for the very best in rolling bearings, but it now stands for much more.

**SKF – the knowledge engineering company**

# Contents

## 1 Foreword

**Introduction** ..... 3

**Traditional connections** ..... 3

## 2 Product information

**About SKF FX Keyless Bushings** ..... 4

**A truly innovative concentric locking technology** ..... 4

**Minimum hub diameter calculation** ..... 4

**SKF FX Keyless Bushings models** ..... 6

## 3 Product data

**Product tables** ..... 8

## 4 Additional information

**SKF – the knowledge engineering company** ..... 30

# SKF FX Keyless Bushings

## Introduction

SKF FX Keyless Bushings are designed to secure gears, couplings and pulleys to a shaft using mechanical friction rather than using traditional keyways, splines or an interference fit. In general, the size of a shaft is dependant on a number of factors. If splines or keyways are cut into a shaft, the shaft is weakened and a larger-than-necessary shaft must be specified. If, however, the objective is to reduce shaft size, weight, machining costs and installation time while improving accuracy and reliability, SKF FX Keyless Bushings are an excellent solution.

SKF FX Keyless Bushings are available in 16 different designs, enabling machine designers to match the best bushing solution to the application. The bushings, which are made from high quality steel, meet SKF standards for precision and quality.

SKF FX Keyless Bushings are designed to accurately and effectively mount components to a shaft. These components, which normally require sophisticated broaching or milling techniques to prepare the shaft, can now be mounted with a minimum amount of machining. This not only saves time, it can also significantly reduce production costs.

In the past, the torque capacity of an application was limited by the keyway, spline or interference fit. The use of keyways meant that over-designed shafts were used to accommodate the structural loss of strength (→ **fig. 1**). As a consequence, shaft costs increased considerably.

However, SKF FX Keyless Bushings have changed that by placing torque limits on the design of the hub and material of the shaft.

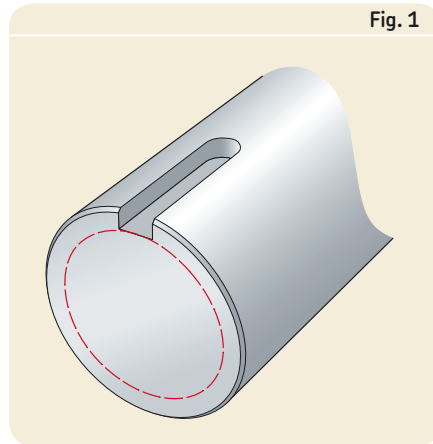

Fig. 1

*For keyed bushings, the shaft diameters need to be increased by 20–30% to cover the expected weakening caused by the keyways*

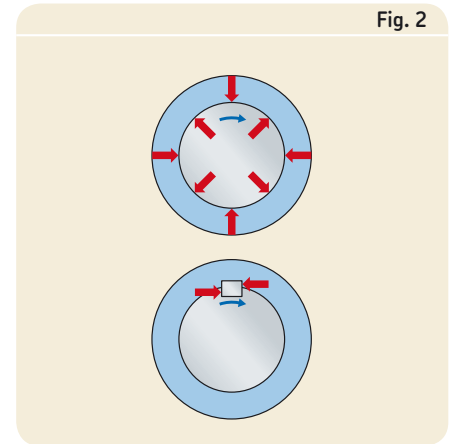

Fig. 2

*Traditional connections*

## Traditional connections

Traditional connections include interference fits (also called press fits and shrink fits) keyways, keyed bushing systems, QD and tapered bushings (→ **fig. 2**).

Interference fits offer some advantages, like zero backlash and uniform contact pressures. Interference fits also have distinct disadvantages such as extended fit lengths and the need for extremely close machining tolerances of the shaft and component bore. Also, depending on the size of the shaft, the use of a press or heat source might be necessary. In addition, maintenance is often difficult and components can seldom be reused.

Keys and keyways have been around for quite some time and keyed tapered bushings are especially popular around the globe as the same basic bushing can be accommodated on different shaft sizes. Keys and keyways are relatively easy to prepare, quick to install and provide a low cost solution. Although

they are commonly used, they are surprisingly ineffective. When keyways are cut into components and shafts, they reduce the cross section and, consequently, the strength of the machined parts. As a result, any shafts, gears or pulleys containing a keyway must be oversized to compensate for the reduced cross section. Keys and keyways require a clearance fit on several planes. The combined effect of these clearances is backlash, which in some cases can enlarge the keyways, while promoting fatigue failures and fretting corrosion.

## About SKF FX Keyless Bushings

SKF FX Keyless Bushings are designed to create an interference fit with uniform contact pressure on shafts and components that must be fixed to the shaft. The design offers true zero backlash installation and has none of the problems associated with keyways. SKF FX Keyless Bushings make it easy to mount components with a cylindrical (non-tapered) bore to standard, plain shafting and can even be mounted over an existing keyway if necessary.

These bushings, which can accommodate wide component tolerances, can considerably reduce machining and material costs.

In addition, SKF FX Keyless Bushings are easy to adjust axially and radially, and are simple to install and remove.

## A truly innovative concentric locking technology

The concept behind SKF FX Keyless Bushings is based on two inclined planes working against each other. As a series of screws or a single hexagonal nut is tightened, two steel rings with inclined serrations are displaced axially. This forces one steel ring to expand in the component bore while the other ring contracts evenly around the shaft. The result is a true concentric, tight fit.

The near perfect 360 degree grip on the shaft and in the component bore eliminates shaft damage and the possibility of fretting corrosion.

## Minimum hub diameter calculation

SKF FX Keyless Bushings use opposing inclined planes to apply pressure on a shaft and hub. This pressure can be quite significant and could exceed the material strength of the hub and shaft. The shaft values are only critical if the shaft is hollow, but, in all cases, the forces on the hub must be calculated.

When calculating the minimum hub diameter, the length and shape of a hub influences the results. The data required to calculate the minimum hub diameter are:

- The hub surface pressure from the product tables for each size
- Select the shape factor based on the installation setup (→ **fig. 3**)
- The hub material yield strength (→ **table 1**)

To calculate the required minimum hub diameter for each application, follow the example below.

### Example

With an application using a selected model PHF FX10-50X80. From the product table, the listed hub surface pressure ( $P_n$  N/mm<sup>2</sup>) is 115 N/mm<sup>2</sup>.

- This bushing requires a centering hub (→ **fig. 3**), Shape factor  $f = 0,8$ .
- The hub, made from mild steel, has a material yield strength of 220 N/mm<sup>2</sup> (→ **table 1**).
- From **table 2**, we can determine the factor for the ratio to be applied to the hub diameter 1,56, which has to be multiplied by D.
- The minimum hub diameter is 80 mm × 1,56 = 124,8 mm for full power transmission capability.

Table 1

### Material yield strength values

Yield strength	Material
N/mm <sup>2</sup>	–
180	Cast iron
600	SG iron
220	Mild steel
550	Gear steel
195–225	18/8 Austenitic stainless steel
565–608	Cast steels 0,3% carbon
95–125	Aluminium
180	Aluminium alloy Hs 30W
415	4,5% Cu – Aluminium alloy

### Shape factor based on installation setup

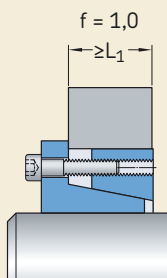

Narrow hubs with length  $\geq L_1$

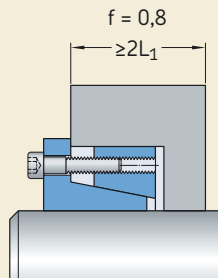

Wider hubs with centering guides, length  $\geq 2L_1$

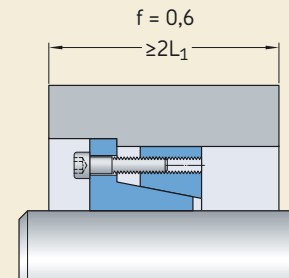

Wider hubs without centering guides, length  $\geq 2L_1$

Fig. 3

Table 4

## Ratio selection chart for minimum hub diameter

Hub surface pressure N/mm <sup>2</sup>	Shape factor f	Material yield strength, $\sigma$ [N/mm <sup>2</sup> ]								
		$\sigma = 150$	$\sigma = 180$	$\sigma = 200$	$\sigma = 220$	$\sigma = 250$	$\sigma = 270$	$\sigma = 300$	$\sigma = 350$	$\sigma = 400$
60	0,6	1,28	1,25	1,20	1,18	1,15	1,14	1,12	1,10	1,09
	0,8	1,39	1,30	1,24	1,23	1,22	1,20	1,18	1,15	1,12
	1	1,52	1,42	1,36	1,32	1,28	1,25	1,22	1,18	1,16
65	0,6	1,30	1,25	1,22	1,20	1,18	1,15	1,13	1,11	1,10
	0,8	1,44	1,35	1,30	1,28	1,24	1,22	1,20	1,16	1,14
	1	1,60	1,45	1,40	1,35	1,30	1,28	1,24	1,20	1,18
70	0,6	1,34	1,26	1,24	1,22	1,18	1,16	1,15	1,12	1,11
	0,8	1,48	1,38	1,34	1,30	1,25	1,23	1,20	1,18	1,15
	1	1,65	1,50	1,45	1,40	1,34	1,30	1,26	1,22	1,20
75	0,6	1,30	1,28	1,25	1,23	1,20	1,18	1,16	1,14	1,12
	0,8	1,52	1,42	1,36	1,32	1,28	1,25	1,22	1,18	1,16
	1	1,74	1,55	1,48	1,42	1,36	1,33	1,30	1,25	1,20
80	0,6	1,39	1,31	1,28	1,25	1,21	1,20	1,18	1,15	1,13
	0,8	1,58	1,45	1,39	1,35	1,30	1,27	1,24	1,20	1,18
	1	1,81	1,61	1,53	1,46	1,39	1,36	1,31	1,26	1,22
85	0,6	1,42	1,34	1,30	1,27	1,23	1,21	1,19	1,16	1,14
	0,8	1,53	1,49	1,42	1,38	1,32	1,29	1,26	1,22	1,19
	1	1,90	1,67	1,57	1,50	1,42	1,39	1,34	1,28	1,24
90	0,6	1,46	1,36	1,32	1,28	1,25	1,22	1,20	1,17	1,15
	0,8	1,69	1,53	1,46	1,40	1,34	1,31	1,28	1,23	1,20
	1	2,00	1,73	1,62	1,54	1,46	1,41	1,38	1,30	1,26
95	0,6	1,49	1,39	1,34	1,30	1,26	1,24	1,21	1,18	1,15
	0,8	1,75	1,57	1,49	1,43	1,37	1,34	1,30	1,25	1,21
	1	2,11	1,80	1,68	1,59	1,49	1,44	1,39	1,32	1,27
100	0,6	1,53	1,41	1,36	1,32	1,28	1,25	1,22	1,19	1,16
	0,8	1,81	1,61	1,53	1,46	1,39	1,36	1,31	1,26	1,22
	1	2,24	1,87	1,73	1,63	1,53	1,48	1,41	1,34	1,29
105	0,6	1,56	1,44	1,39	1,34	1,29	1,27	1,24	1,20	1,17
	0,8	1,88	1,66	1,56	1,50	1,42	1,38	1,33	1,28	1,24
	1	2,38	1,95	1,79	1,68	1,56	1,51	1,44	1,36	1,31
110	0,6	1,60	1,47	1,41	1,36	1,31	1,28	1,25	1,21	1,18
	0,8	1,96	1,71	1,60	1,53	1,44	1,37	1,35	1,29	1,25
	1	2,55	2,04	1,96	1,73	1,60	1,54	1,47	1,38	1,33
115	0,6	1,64	1,50	1,43	1,36	1,33	1,30	1,26	1,22	1,19
	0,8	2,04	1,76	1,64	1,56	1,47	1,43	1,37	1,31	1,26
	1	2,75	2,13	1,93	1,79	1,64	1,58	1,50	1,41	1,43
120	0,6	1,69	1,53	1,46	1,40	1,34	1,31	1,28	1,23	1,20
	0,8	2,13	1,81	1,69	1,60	1,50	1,45	1,39	1,33	1,29
	1	3,00	2,24	2,00	1,84	1,69	1,61	1,53	1,43	1,36
125	0,6	1,73	1,56	1,48	1,43	1,36	1,33	1,29	1,24	1,21
	0,8	2,24	1,87	1,73	1,63	1,53	1,48	1,41	1,34	1,29
	1	3,32	2,35	2,08	1,91	1,73	1,65	1,56	1,45	1,38
130	0,6	1,78	1,59	1,51	1,45	1,38	1,35	1,30	1,25	1,22
	0,8	2,35	1,93	1,78	1,67	1,56	1,50	1,44	1,36	1,30
	1	3,74	2,49	2,17	1,97	1,78	1,69	1,59	1,48	1,40
135	0,6	1,83	1,62	1,54	1,47	1,40	1,36	1,32	1,27	1,23
	0,8	2,48	2,00	1,83	1,71	1,59	1,53	1,46	1,38	1,32
	1	4,36	2,65	2,27	2,04	1,83	1,73	1,62	1,50	1,42
140	0,6	1,88	1,66	1,56	1,50	1,42	1,38	1,33	1,28	1,24
	0,8	2,63	2,07	1,88	1,75	1,62	1,55	1,48	1,39	1,33
	1	5,39	2,83	2,38	2,12	1,88	1,78	1,66	1,53	1,44
145	0,6	1,94	1,69	1,59	1,52	1,44	1,40	1,35	1,29	1,25
	0,8	2,80	2,15	1,94	1,80	1,65	1,58	1,50	1,41	1,35
	1	7,68	3,05	2,50	2,21	1,94	1,82	1,69	1,55	1,46
150	0,6	2,00	1,73	1,62	1,54	1,46	1,41	1,36	1,30	1,26
	0,8	3,00	2,24	2,00	1,84	1,69	1,61	1,53	1,43	1,36
	1	–	3,32	2,65	2,30	2,00	1,87	1,73	1,58	1,48
155	0,6	2,06	1,77	1,65	1,57	1,48	1,43	1,38	1,31	1,27
	0,8	3,25	2,33	2,06	1,89	1,72	1,65	1,55	1,45	1,38
	1	–	3,66	2,80	2,40	2,06	1,92	1,77	1,61	1,51
160	0,6	2,13	1,81	1,69	1,60	1,50	1,45	1,39	1,33	1,28
	0,8	3,55	2,43	2,13	1,94	1,76	1,67	1,58	1,47	1,39
	1	–	4,12	3,00	2,52	2,13	1,98	1,81	1,64	1,53
165	0,6	2,21	1,86	1,72	1,62	1,52	1,47	1,41	1,34	1,29
	0,8	3,96	2,55	2,21	2,00	1,80	1,71	1,60	1,49	1,41
	1	–	4,80	3,23	2,65	2,21	2,04	1,86	1,67	1,56
170	0,6	2,29	1,90	1,76	1,65	1,54	1,49	1,42	1,35	1,30
	0,8	4,52	2,68	2,29	2,06	1,84	1,74	1,63	1,51	1,42
	1	–	5,92	3,51	2,79	2,29	2,10	1,90	1,70	1,57

# SKF FX Keyless Bushings models



- FX 10**
- Medium torque
  - Not self-centering
  - Medium surface pressures
  - No axial hub movement
  - H11 – h11 tolerances



- FX 50**
- Medium torque
  - Self-centering
  - Low surface pressures
  - No axial hub movement
  - H8 – h8 tolerances



- FX 20**
- Medium torque
  - Self-centering
  - H8 – h8 tolerances



- FX 51**
- Medium torque
  - Reduced length
  - High surface pressures
  - No axial hub movement
  - H8 – h8 tolerances



- FX 30**
- Low torque
  - Medium surface pressures
  - Taper rings only



- FX 52**
- High torque
  - Self-centering
  - Low-medium surface pressures
  - H8 – h8 tolerances



- FX 40**
- High torque
  - Self-centering
  - Medium surface pressures
  - H8 – h8 tolerances



- FX 60**
- Very high torque
  - Self-centering
  - Medium surface pressures
  - No axial hub movement
  - H8 – h8 tolerances



- FX 41**
- Medium torque
  - Reduced length
  - Medium self-centering
  - High surface pressures
  - H8 – h8 tolerances



- FX 80**
- Low torque
  - Short length
  - Not self-centering
  - Low surface pressures
  - H8 – h8 tolerances



- FX 90**
- Low-medium torque
  - Short length
  - Self-centering
  - Low surface pressures
  - H8 – h8 tolerances



- FX 350**
- Low-medium torque
  - Short length
  - Self-centering
  - Low surface pressures
  - H8 – h8 tolerances



- FX 120**
- Medium torque
  - Reduced length
  - Medium self-centering
  - High surface pressures
  - Reduced length
  - H8 – h8 tolerances



- FX 400**
- High torque
  - Self-centering
  - Low surface pressures
  - No axial hub movement
  - H8 – h8 tolerances



- FX 130**
- Low-medium torque
  - h8 tolerances



- FX 140**
- Medium torque
  - Reduced length
  - High surface pressures
  - H8 – h8 tolerances

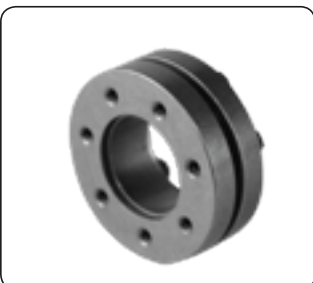

- FX 190**
- High torque
  - No axial hub movement
  - h8 tolerances



**FX10**  
d 20 – 900 mm

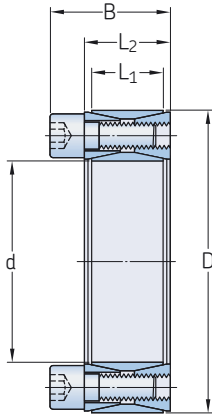

Dimensions					Performance		Pressure		Clamp screws			Weight	Designation
d	D	L <sub>1</sub>	L <sub>2</sub>	B	Transmissible axial force F <sub>t</sub>	Transmissible torque M <sub>t</sub>	Shaft surface P <sub>w</sub>	Hub surface P <sub>n</sub>	Qty	Size	Tightening torque M <sub>s</sub>	kg	–
mm					kN	Nm	N/mm <sup>2</sup>	N/mm <sup>2</sup>	–	–	Nm	kg	–
20	47	17	20	27,5	27	240	210	90	8	M6	15	0,2	PHF FX10-20X47
22	47	17	20	27,5	27	300	195	90	8	M6	15	0,2	PHF FX10-22X47
24	50	17	20	27,5	30	360	195	95	8	M6	15	0,3	PHF FX10-24X50
25	50	17	20	27,5	30	380	190	95	8	M6	15	0,3	PHF FX10-25X50
28	55	17	20	27,5	33	470	185	95	10	M6	15	0,3	PHF FX10-28X55
30	55	17	20	27,5	33	500	175	95	10	M6	15	0,3	PHF FX10-30X55
32	60	17	20	27,5	40	630	192	105	12	M6	15	0,3	PHF FX10-32X60
35	60	17	20	27,5	40	700	180	105	12	M6	15	0,3	PHF FX10-35X60
38	65	17	20	27,5	46	870	188	110	14	M6	15	0,4	PHF FX10-38X65
40	65	17	20	27,5	46	920	180	110	14	M6	15	0,3	PHF FX10-40X65
42	75	20	24	33,5	72	1 500	226	125	12	M8	37	0,6	PHF FX10-42X75
45	75	20	24	33,5	72	1 610	210	125	12	M8	37	0,6	PHF FX10-45X75
48	80	20	24	33,5	71	1 700	196	115	12	M8	37	0,6	PHF FX10-48X80
50	80	20	24	33,5	71	1 770	190	115	12	M8	37	0,6	PHF FX10-50X80
55	85	20	24	33,5	83	2 270	200	130	14	M8	37	0,6	PHF FX10-55X85
60	90	20	24	33,5	83	2 470	180	120	14	M8	37	0,7	PHF FX10-60X90
65	95	20	24	33,5	93	3 040	190	130	16	M8	37	0,7	PHF FX10-65X95
70	110	24	28	39,5	132	4 600	210	130	14	M10	70	1,3	PHF FX10-70X110
75	115	24	28	39,5	131	4 900	195	125	14	M10	70	1,3	PHF FX10-75X115
80	120	24	28	39,5	131	5 200	180	120	14	M10	70	1,4	PHF FX10-80X120
85	125	24	28	39,5	148	6 300	195	130	16	M10	70	1,4	PHF FX10-85X125
90	130	24	28	39,5	147	6 600	180	125	16	M10	70	1,5	PHF FX10-90X130
95	135	24	28	39,5	167	7 900	195	135	18	M10	70	1,6	PHF FX10-95X135
100	145	26	33	47	192	9 600	195	135	14	M12	127	2,2	PHF FX10-100X145
110	155	26	33	47	191	10 500	180	125	14	M12	127	2,5	PHF FX10-110X155
120	165	26	33	47	218	13 100	185	135	16	M12	127	2,6	PHF FX10-120X165
130	180	34	38	52	272	17 600	165	115	20	M12	127	3,8	PHF FX10-130X180
140	190	34	38	52	298	20 900	165	125	22	M12	127	3,9	PHF FX10-140X190
150	200	34	38	52	324	24 200	170	125	24	M12	127	4,0	PHF FX10-150X200
160	210	34	38	52	350	28 000	170	130	26	M12	127	4,3	PHF FX10-160X210
170	225	38	44	60	386	32 800	160	120	22	M14	195	5,8	PHF FX10-170X225
180	235	38	44	60	420	37 800	165	125	24	M14	195	6,0	PHF FX10-180X235
190	250	46	52	68	490	46 500	150	115	28	M14	195	8,5	PHF FX10-190X250
200	260	46	52	68	525	52 500	150	115	30	M14	195	8,6	PHF FX10-200X260
220	285	50	56	74	620	68 000	150	115	26	M16	300	11,0	PHF FX10-220X285
240	305	50	56	74	715	85 500	160	125	30	M16	300	12,0	PHF FX10-240X305
260	325	50	56	74	800	104 000	165	130	34	M16	300	13,0	PHF FX10-260X325
280	355	60	66	86,5	915	128 000	145	115	32	M18	410	19,0	PHF FX10-280X355
300	375	60	66	86,5	1 020	153 000	150	120	36	M18	410	20,0	PHF FX10-300X375
320	405	72	78	100,5	1 310	210 000	150	120	36	M20	590	30,0	PHF FX10-320X405



Dimensions					Performance		Pressure		Clamp screws			Weight	Designation
d	D	L <sub>1</sub>	L <sub>2</sub>	B	Transmissible axial force F <sub>t</sub>	Transmissible torque M <sub>t</sub>	Shaft surface P <sub>w</sub>	Hub surface P <sub>n</sub>	Qty	Size	Tightening torque M <sub>s</sub>	kg	–
mm					kN	Nm	N/mm <sup>2</sup>	N/mm <sup>2</sup>	–	–	Nm	kg	–
<b>340</b>	425	72	78	100,5	1 310	224 000	145	115	36	M20	590	30,1	PHF FX10-340X425
<b>360</b>	455	84	90	116	1 630	294 000	145	115	36	M22	790	42,0	PHF FX10-360X455
<b>380</b>	475	84	90	116	1 620	308 000	135	110	36	M22	790	44,0	PHF FX10-380X475
<b>400</b>	495	84	90	116	1 610	322 000	130	105	36	M22	790	46,0	PHF FX10-400X495
<b>420</b>	515	84	90	116	1 780	370 000	135	110	40	M22	790	50,0	PHF FX10-420X515
<b>440</b>	545	96	102	130	2 050	450 000	130	105	40	M24	1 000	65,0	PHF FX10-440X545
<b>460</b>	565	96	102	130	2 030	465 000	125	100	40	M24	1 000	67,0	PHF FX10-460X565
<b>480</b>	585	96	102	130	2 150	505 000	125	100	42	M24	1 000	71,0	PHF FX10-480X585
<b>500</b>	605	96	102	130	2 200	553 000	125	100	44	M24	1 000	73,0	PHF FX10-500X605
<b>520</b>	630	96	102	130	2 300	592 000	125	100	45	M24	1 000	80,0	PHF FX10-520X630
<b>540</b>	650	96	102	130	2 320	618 000	120	100	45	M24	1 000	82,0	PHF FX10-540X650
<b>560</b>	670	96	102	130	2 430	670 000	120	100	48	M24	1 000	85,0	PHF FX10-560X670
<b>580</b>	690	96	102	130	2 520	727 000	120	100	50	M24	1 000	88,0	PHF FX10-580X690
<b>600</b>	710	96	102	130	2 565	770 000	120	100	50	M24	1 000	91,0	PHF FX10-600X710
<b>620</b>	730	96	102	130	2 647	818 000	120	100	52	M24	1 000	93,0	PHF FX10-620X730
<b>640</b>	750	96	102	130	2 698	860 000	115	100	54	M24	1 000	96,0	PHF FX10-640X750
<b>660</b>	770	96	102	130	2 790	919 000	120	100	56	M24	1 000	99,0	PHF FX10-660X770
<b>680</b>	790	96	102	130	2 820	955 000	115	100	56	M24	1 000	102,0	PHF FX10-680X790
<b>700</b>	810	96	102	130	2 945	1 018 000	115	100	60	M24	1 000	104,0	PHF FX10-700X810
<b>720</b>	830	96	102	130	2 965	1 060 000	115	100	60	M24	1 000	107,0	PHF FX10-720X830
<b>740</b>	850	96	102	130	3 065	1 128 000	115	100	62	M24	1 000	110,0	PHF FX10-740X850
<b>760</b>	870	96	102	130	3 170	1 200 000	115	100	64	M24	1 000	113,0	PHF FX10-760X870
<b>780</b>	890	96	102	130	3 205	1 235 000	115	100	65	M24	1 000	116,0	PHF FX10-780X890
<b>800</b>	910	96	102	130	3 260	1 287 000	115	100	66	M24	1 000	118,0	PHF FX10-800X910
<b>820</b>	930	96	102	130	3 330	1 360 000	115	100	68	M24	1 000	121,0	PHF FX10-820X930
<b>840</b>	950	96	102	130	3 445	1 435 000	115	100	70	M24	1 000	124,0	PHF FX10-840X950
<b>860</b>	970	96	102	130	3 525	1 510 000	115	100	72	M24	1 000	127,0	PHF FX10-860X970
<b>880</b>	990	96	102	130	3 610	1 578 000	115	100	74	M24	1 000	129,0	PHF FX10-880X990
<b>900</b>	1 010	96	102	130	3 660	1 635 000	115	100	75	M24	1 000	132,0	PHF FX10-900X1010

**FX20**  
d 6 – 130 mm

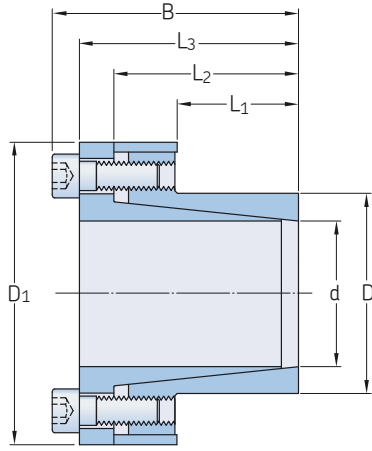

Dimensions			Performance		Pressure		Clamp screws			Weight	Designation				
d	D	L <sub>1</sub>	L <sub>2</sub>	L <sub>3</sub>	B	D <sub>1</sub>	Transmissible axial force F <sub>t</sub>	Transmissible torque M <sub>t</sub>	Shaft surface P <sub>w</sub>	Hub surface P <sub>n</sub>	Qty	Size	Tightening torque M <sub>s</sub>		
mm							kN	Nm	N/mm <sup>2</sup>	N/mm <sup>2</sup>	–	–	Nm	kg	–
6	14	10	18,5	21	24	25	4,5	13	190	80	3	M3	2	0,04	PHF FX20-6X14
7	15	12	22	25	29	27	6,5	24	230	110	3	M4	4,9	0,06	PHF FX20-7X15
8	15	12	22	25	29	27	6,65	25	210	110	3	M4	4,9	0,05	PHF FX20-8X15
9	16	14	23	26	30	28	9,98	45	210	120	4	M4	4,9	0,06	PHF FX20-9X16
10	16	14	23	26	30	28	9,98	49	180	120	4	M4	4,9	0,06	PHF FX20-10X16
11	18	14	23	26	30	32	9,98	54	170	105	4	M4	4,9	0,07	PHF FX20-11X18
12	18	14	23	26	30	32	9,98	60	155	105	4	M4	4,9	0,07	PHF FX20-12X18
13	23	14	23	26	30	38	9,98	63	145	85	4	M4	4,9	0,11	PHF FX20-13X23
14	23	14	23	26	30	38	9,98	70	135	85	4	M4	4,9	0,10	PHF FX20-14X23
15	24	16	29	36	42	45	17,1	120	185	120	3	M6	17	0,22	PHF FX20-15X24
16	24	16	29	36	42	45	17,1	140	180	120	3	M6	17	0,22	PHF FX20-16X24
17	26	18	31	38	44	47	22	180	190	125	4	M6	17	0,25	PHF FX20-17X26
18	26	18	31	38	44	47	22	200	180	125	4	M6	17	0,24	PHF FX20-18X26
19	27	18	31	38	44	49	22	210	170	120	4	M6	17	0,26	PHF FX20-19X27
20	28	18	31	38	44	50	22	220	160	115	4	M6	17	0,27	PHF FX20-20X28
22	32	25	38	45	51	54	22	250	115	80	4	M6	17	0,34	PHF FX20-22X32
24	34	25	38	45	51	56	22	270	105	75	4	M6	17	0,36	PHF FX20-24X34
25	34	25	38	45	51	56	22	290	100	75	4	M6	17	0,35	PHF FX20-25X34
28	39	25	38	45	51	61	33	465	135	100	6	M6	17	0,48	PHF FX20-28X39
30	41	25	38	45	51	62	33	510	125	90	6	M6	17	0,48	PHF FX20-30X41
32	43	25	38	45	51	65	33	540	120	90	6	M6	17	0,47	PHF FX20-32X43
35	47	32	45	52	58	69	45	790	105	80	8	M6	17	0,58	PHF FX20-35X47
39	50	32	45	52	58	72	45	860	100	75	8	M6	17	0,61	PHF FX20-39X50
40	53	32	45	52	58	75	45	900	95	70	8	M6	17	0,68	PHF FX20-40X53
42	55	32	45	52	58	78	45	950	90	70	8	M6	17	0,76	PHF FX20-42X55
45	59	45	62	70	78	86	84	1 890	110	85	8	M8	41	1,2	PHF FX20-45X59
48	62	45	62	70	78	87	84	2 010	105	80	8	M8	41	1,2	PHF FX20-48X62
50	65	45	62	70	78	92	84	2 100	100	75	8	M8	41	1,4	PHF FX20-50X65
55	71	55	72	80	88	98	94	2 600	85	65	9	M8	41	1,6	PHF FX20-55X71
60	77	55	72	80	88	104	94	2 840	75	60	9	M8	41	1,8	PHF FX20-60X77
65	84	55	72	80	88	111	94	3 070	70	55	9	M8	41	2,1	PHF FX20-65X84
70	90	65	86	96	106	119	150	5 250	90	70	9	M10	83	3,0	PHF FX20-70X90
75	95	65	86	96	106	126	150	5 600	80	65	9	M10	83	3,0	PHF FX20-75X95
80	100	65	86	96	106	131	200	8 020	100	80	12	M10	83	3,5	PHF FX20-80X100
85	106	65	86	96	106	137	200	8 500	95	75	12	M10	83	3,6	PHF FX20-85X106
90	112	65	86	96	106	144	200	9 000	90	75	12	M10	83	3,9	PHF FX20-90X112
95	120	65	86	96	106	149	230	11 000	100	80	14	M10	83	4,4	PHF FX20-95X120
100	125	65	86	96	106	154	300	15 000	120	95	18	M10	83	4,6	PHF FX20-100X125
110	140	90	114	128	140	180	290	16 000	80	65	12	M12	145	8,7	PHF FX20-110X140
120	155	90	114	128	140	198	290	17 500	70	55	12	M12	145	10,6	PHF FX20-120X155
130	165	90	114	128	140	208	384	25 000	90	70	16	M12	145	11,3	PHF FX20-130X165

**FX30**  
d 6 – 95 mm

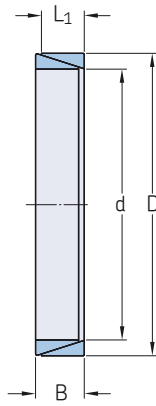

Dimensions				Performance		Pressure		Weight	Designation
d	D	L <sub>1</sub>	B	Transmissible axial force F <sub>t</sub>	Transmissible torque M <sub>t</sub>	Shaft surface P <sub>w</sub>	Hub surface P <sub>n</sub>		
mm				kN	Nm	N/mm <sup>2</sup>	N/mm <sup>2</sup>	kg	–
6	9	3,7	4,5	0,84	2,5	115	75	0,002	PHF FX30-6X9
7	10	3,7	4,5	0,86	3	105	70	0,002	PHF FX30-7X10
8	11	3,7	4,5	1,17	4,7	120	90	0,002	PHF FX30-8X11
9	12	3,7	4,5	1,76	7,9	140	105	0,002	PHF FX30-9X12
10	13	3,7	4,5	1,91	9,5	135	105	0,002	PHF FX30-10X13
12	15	3,7	4,5	1,91	11,4	115	90	0,002	PHF FX30-12X15
13	16	3,7	4,5	2,02	13,1	110	90	0,002	PHF FX30-13X16
14	18	5,3	6,3	3,18	22,3	115	90	0,005	PHF FX30-14X18
15	19	5,3	6,3	3,24	24,3	110	85	0,005	PHF FX30-15X19
16	20	5,3	6,3	3,42	27,3	105	85	0,006	PHF FX30-16X20
17	21	5,3	6,3	3,51	29,8	105	85	0,006	PHF FX30-17X21
18	22	5,3	6,3	3,61	32,4	100	80	0,007	PHF FX30-18X22
19	24	5,3	6,3	5,22	49	140	110	0,007	PHF FX30-19X24
20	25	5,3	6,3	5,33	53	135	105	0,009	PHF FX30-20X25
22	26	5,3	6,3	6	66	135	115	0,007	PHF FX30-22X26
24	28	5,3	6,3	6,13	73	130	110	0,008	PHF FX30-24X28
25	30	5,3	6,3	5,77	72	115	95	0,009	PHF FX30-25X30
28	32	5,3	6,3	6,33	86	115	100	0,01	PHF FX30-28X32
30	35	5,3	6,3	6,08	91	100	85	0,011	PHF FX30-30X35
32	36	5,3	6,3	8,24	131	130	115	0,011	PHF FX30-32X36
35	40	6,0	7,0	9,77	171	125	110	0,016	PHF FX30-35X40
36	42	6,0	7,0	9,39	169	115	100	0,021	PHF FX30-36X42
38	44	6,0	7,0	9,55	181	110	95	0,021	PHF FX30-38X44
40	45	6,6	8,0	11,57	231	115	105	0,021	PHF FX30-40X45
42	48	6,6	8,0	11,22	235	110	95	0,026	PHF FX30-42X48
45	52	8,6	10,0	15,71	353	105	95	0,045	PHF FX30-45X52
48	55	8,6	10,0	23,84	572	155	135	0,043	PHF FX30-48X55
50	57	8,6	10,0	24,08	602	150	130	0,045	PHF FX30-50X57
55	62	8,6	10,0	24,35	670	140	125	0,049	PHF FX30-55X62
56	64	10,4	12,0	28,2	790	130	115	0,07	PHF FX30-56X64
60	68	10,4	12,0	28,6	860	125	110	0,07	PHF FX30-60X68
63	71	10,4	12,0	28,8	910	120	105	0,08	PHF FX30-63X71
65	73	10,4	12,0	29,2	950	115	100	0,09	PHF FX30-65X73
70	79	12,2	14,0	39,4	1 380	125	110	0,115	PHF FX30-70X79
71	80	12,2	14,0	39,4	1 400	120	110	0,11	PHF FX30-71X80
75	84	12,2	14,0	38,6	1 450	115	100	0,12	PHF FX30-75X84
80	91	15,0	17,0	55	2 200	125	105	0,21	PHF FX30-80X91
85	96	15,0	17,0	56,4	2 400	120	105	0,21	PHF FX30-85X96
90	101	15,0	17,0	60,5	2 730	120	105	0,22	PHF FX30-90X101
95	106	15,0	17,0	64,2	3 050	120	110	0,23	PHF FX30-95X106

**FX30**  
d 100 – 540 mm

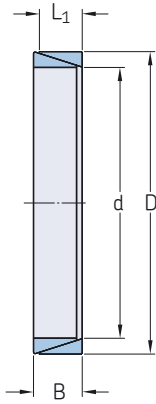

Dimensions				Performance Transmissible axial force $F_t$	Transmissible torque $M_t$	Pressure		Weight	Designation
d	D	$L_1$	B			Shaft surface $P_w$	Hub surface $P_n$		
mm				kN	Nm	N/mm <sup>2</sup>	N/mm <sup>2</sup>	kg	-
<b>100</b>	114	18,7	21	84	4 200	120	105	0,39	<b>PHF FX30-100X114</b>
<b>110</b>	124	18,7	21	93,6	5 150	120	105	0,42	<b>PHF FX30-110X124</b>
<b>120</b>	134	18,7	21	100,8	6 050	120	105	0,46	<b>PHF FX30-120X134</b>
<b>130</b>	148	25,3	28	147,6	9 600	120	105	0,86	<b>PHF FX30-130X148</b>
<b>140</b>	158	25,3	28	158,5	11 000	120	105	0,96	<b>PHF FX30-140X158</b>
<b>150</b>	168	25,3	28	172	12 900	120	105	1	<b>PHF FX30-150X168</b>
<b>160</b>	178	25,3	28	182,5	14 600	120	110	1	<b>PHF FX30-160X178</b>
<b>170</b>	191	30	33	229	19 500	120	105	1,54	<b>PHF FX30-170X191</b>
<b>180</b>	201	30	33	236	21 300	120	105	1,5	<b>PHF FX30-180X201</b>
<b>190</b>	211	30	33	255	24 200	120	110	1,8	<b>PHF FX30-190X211</b>
<b>200</b>	224	34,8	38	310	31 000	120	105	2,4	<b>PHF FX30-200X224</b>
<b>210</b>	234	34,8	38	333	35 000	120	110	2,5	<b>PHF FX30-210X234</b>
<b>220</b>	244	34,8	38	345	38 000	120	110	2,6	<b>PHF FX30-220X244</b>
<b>230</b>	257	39,5	43	408	47 000	120	105	3,4	<b>PHF FX30-230X257</b>
<b>240</b>	267	39,5	43	425	51 000	120	110	3,8	<b>PHF FX30-240X267</b>
<b>250</b>	280	44	48	415	52 000	100	90	4,8	<b>PHF FX30-250X280</b>
<b>260</b>	290	44	48	435	56 500	100	90	4,9	<b>PHF FX30-260X290</b>
<b>270</b>	300	44	48	450	61 000	100	90	5	<b>PHF FX30-270X300</b>
<b>280</b>	313	49	53	520	72 500	100	90	6,4	<b>PHF FX30-280X313</b>
<b>290</b>	323	49	53	535	77 500	100	90	6,5	<b>PHF FX30-290X323</b>
<b>300</b>	333	49	53	555	83 000	100	90	6,8	<b>PHF FX30-300X333</b>
<b>320</b>	360	59	65	710	114 000	100	90	11	<b>PHF FX30-320X360</b>
<b>340</b>	380	59	65	755	128 500	100	90	11,5	<b>PHF FX30-340X380</b>
<b>360</b>	400	59	65	800	144 000	100	90	12,3	<b>PHF FX30-360X400</b>
<b>380</b>	420	59	65	845	160 500	100	90	13	<b>PHF FX30-380X420</b>
<b>400</b>	440	59	65	890	178 000	100	90	13,7	<b>PHF FX30-400X440</b>
<b>420</b>	460	59	65	935	196 000	100	90	14,1	<b>PHF FX30-420X460</b>
<b>440</b>	480	59	65	980	215 000	100	90	14,8	<b>PHF FX30-440X480</b>
<b>460</b>	500	59	65	1 020	235 000	100	90	15,5	<b>PHF FX30-460X500</b>
<b>480</b>	520	59	65	1 070	256 000	100	90	16	<b>PHF FX30-480X520</b>
<b>500</b>	540	59	65	1 110	278 000	100	90	16,7	<b>PHF FX30-500X540</b>
<b>520</b>	570	73	80	1 430	372 000	100	90	27	<b>PHF FX30-520X570</b>
<b>540</b>	590	73	80	1 480	400 000	100	90	28	<b>PHF FX30-540X590</b>

**FX40**

d 20 – 140 mm

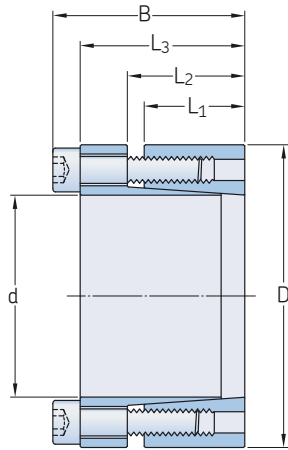

Dimensions						Performance		Pressure		Clamp screws			Weight	Designation
d	D	L <sub>1</sub>	L <sub>2</sub>	L <sub>3</sub>	B	Transmissible axial force F <sub>t</sub>	Transmissible torque M <sub>t</sub>	Shaft surface P <sub>w</sub>	Hub surface P <sub>n</sub>	Qty	Size	Tightening torque M <sub>s</sub>	kg	
mm						kN	Nm	N/mm <sup>2</sup>	N/mm <sup>2</sup>	–	–	Nm		–
20	47	26	29	42	48	54	540	250	105	6	M6	17	0,4	PHF FX40-20X47
22	47	26	29	42	48	54	600	230	105	6	M6	17	0,4	PHF FX40-22X47
24	50	26	29	42	48	54	650	210	100	6	M6	17	0,4	PHF FX40-24X50
25	50	26	29	42	48	54	680	200	100	6	M6	17	0,4	PHF FX40-25X50
28	55	26	29	42	48	54	760	180	95	6	M6	17	0,5	PHF FX40-28X55
30	55	26	29	42	48	54	820	170	95	6	M6	17	0,5	PHF FX40-30X55
32	60	26	29	42	48	82	1 310	235	125	9	M6	17	0,6	PHF FX40-32X60
35	60	26	29	42	48	82	1 440	215	125	9	M6	17	0,5	PHF FX40-35X60
38	65	26	29	42	48	82	1 560	200	115	9	M6	17	0,6	PHF FX40-38X65
40	65	26	29	42	48	82	1 640	190	115	9	M6	17	0,6	PHF FX40-40X65
42	75	30	34,4	51	59	101	2 130	215	120	6	M8	41	1	PHF FX40-42X75
45	75	30	34,4	51	59	101	2 280	200	120	6	M8	41	1	PHF FX40-45X75
48	80	30	34,4	51	59	101	2 430	190	115	6	M8	41	1,1	PHF FX40-48X80
50	80	30	34,4	51	59	101	2 530	180	115	6	M8	41	1	PHF FX40-50X80
55	85	30	34,4	51	59	152	4 180	245	160	9	M8	41	1,1	PHF FX40-55X85
60	90	30	34,4	51	59	152	4 560	225	150	9	M8	41	1,2	PHF FX40-60X90
65	95	30	34,4	51	59	152	4 940	210	145	9	M8	41	1,3	PHF FX40-65X95
70	110	40	45	56	66	186	6 500	175	110	7	M10	83	2,2	PHF FX40-70X110
75	115	40	45	56	66	186	9 000	165	110	7	M10	83	2,5	PHF FX40-75X115
80	120	40	45	56	66	186	7 400	155	100	7	M10	83	2,6	PHF FX40-80X120
85	125	40	45	56	66	213	9 000	170	115	8	M10	83	2,8	PHF FX40-85X125
90	130	40	45	56	66	213	9 600	160	110	8	M10	83	2,7	PHF FX40-90X130
95	135	40	45	56	66	267	12 600	185	130	10	M10	83	2,9	PHF FX40-95X135
100	145	46	52	65	77	270	13 300	160	105	7	M12	145	3,9	PHF FX40-100X145
110	155	46	52	65	77	270	14 700	140	100	7	M12	145	4,2	PHF FX40-110X155
120	165	46	52	65	77	309	18 400	150	110	8	M12	145	4,8	PHF FX40-120X165
130	180	46	52	65	77	388	25 100	175	125	10	M12	145	5	PHF FX40-130X180
140	190	51	58,5	73,5	87,5	586	40 150	220	160	11	M14	230	6,5	PHF FX40-140X190

**FX41**

d 20 – 200 mm

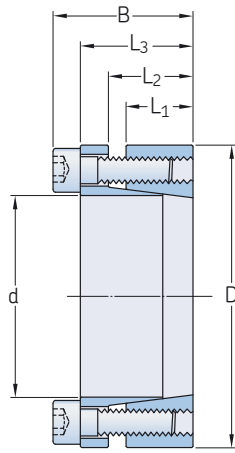

Dimensions						Performance		Pressure		Clamp screws			Weight	Designation
d	D	L <sub>1</sub>	L <sub>2</sub>	L <sub>3</sub>	B	Transmissible axial force F <sub>t</sub>	Transmissible torque M <sub>t</sub>	Shaft surface P <sub>w</sub>	Hub surface P <sub>n</sub>	Qty	Size	Tightening torque M <sub>s</sub>	kg	-
mm						kN	Nm	N/mm <sup>2</sup>	N/mm <sup>2</sup>	-	-	Nm	kg	-
20	47	17	22	28	34	38	380	295	125	5	M6	14	0,3	PHF FX41-20X47
22	47	17	22	28	34	38	410	270	125	5	M6	14	0,3	PHF FX41-22X47
24	50	17	22	28	34	38	450	245	120	5	M6	14	0,3	PHF FX41-24X50
25	50	17	22	28	34	45,6	570	285	140	6	M6	14	0,3	PHF FX41-25X50
28	55	17	22	28	34	45,6	630	255	130	6	M6	14	0,4	PHF FX41-28X55
30	55	17	22	28	34	45,6	660	235	130	6	M6	14	0,4	PHF FX41-30X55
32	60	17	22	28	34	60,5	970	295	155	8	M6	14	0,4	PHF FX41-32X60
35	60	17	22	28	34	60,5	1 060	270	155	8	M6	14	0,4	PHF FX41-35X60
38	65	17	22	28	34	60,5	1 150	250	145	8	M6	14	0,5	PHF FX41-38X65
40	65	17	22	28	34	60,5	1 210	235	145	8	M6	14	0,5	PHF FX41-40X65
42	75	20	25	33	41	98	2 050	300	170	7	M8	35	0,8	PHF FX41-42X75
45	75	20	25	33	41	98	2 200	290	170	7	M8	35	0,7	PHF FX41-45X75
48	80	20	25	33	41	98	2 350	270	160	7	M8	35	0,8	PHF FX41-48X80
50	80	20	25	33	41	98	2 450	260	160	7	M8	35	0,8	PHF FX41-50X80
55	85	20	25	33	41	112	3 080	270	175	8	M8	35	0,9	PHF FX41-55X85
60	90	20	25	33	41	112	3 360	245	165	8	M8	35	0,9	PHF FX41-60X90
65	95	20	25	33	41	126	4 090	255	175	9	M8	35	1	PHF FX41-65X95
70	110	24	30	40	50	179	6 300	280	180	8	M10	70	1,9	PHF FX41-70X110
75	115	24	30	40	50	179	6 700	260	170	8	M10	70	2	PHF FX41-75X115
80	120	24	30	40	50	179	7 150	250	170	8	M10	70	2	PHF FX41-80X120
85	125	24	30	40	50	200	8 500	260	180	9	M10	70	2	PHF FX41-85X125
90	130	24	30	40	50	200	9 100	250	170	9	M10	70	2,2	PHF FX41-90X130
95	135	24	30	40	50	224	10 600	260	180	10	M10	70	2,3	PHF FX41-95X135
100	145	26	32	44	56	268	13 400	270	190	8	M12	125	3	PHF FX41-100X145
110	155	26	32	44	56	268	14 600	240	180	8	M12	125	3,2	PHF FX41-110X155
120	165	26	32	44	56	298	17 900	250	180	9	M12	125	3,4	PHF FX41-120X165
130	180	34	40	54	64	400	26 000	240	170	12	M12	125	5,2	PHF FX41-130X180
140	190	34	40	54	68	384	27 000	210	150	9	M14	190	5,4	PHF FX41-140X190
150	200	34	40	54	68	440	33 000	230	170	10	M14	190	5,7	PHF FX41-150X200
160	210	34	40	54	68	479	38 000	230	170	11	M14	190	6	PHF FX41-160X210
170	225	44	50	64	78	530	45 000	180	130	12	M14	190	8,3	PHF FX41-170X225
180	235	44	50	64	78	530	47 000	170	130	12	M14	190	8,8	PHF FX41-180X235
190	250	44	50	64	78	660	62 900	210	150	15	M14	190	10	PHF FX41-190X250
200	260	44	50	64	78	660	66	190	150	15	M14	190	10,5	PHF FX41-200X260

**FX50**

d 20 – 140 mm

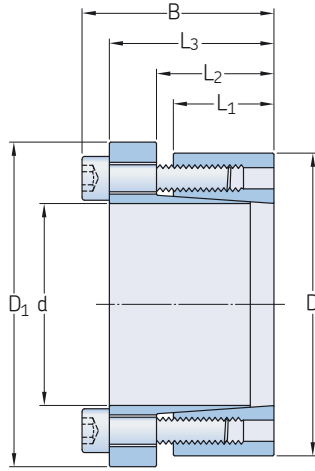

Dimensions			Performance		Pressure		Clamp screws		Weight	Designation					
d	D	L <sub>1</sub>	L <sub>2</sub>	L <sub>3</sub>	B	D <sub>1</sub>	Transmissible axial force F <sub>t</sub>	Transmissible torque M <sub>t</sub>	Shaft surface P <sub>w</sub>	Hub surface P <sub>n</sub>	Qty	Size	Tightening torque M <sub>s</sub>	kg	–
mm							kN	Nm	N/mm <sup>2</sup>	N/mm <sup>2</sup>	–	–	Nm	kg	–
20	47	26	29	42	48	53	33,6	330	155	65	6	M6	17	0,5	PHF FX50-20X47
22	47	26	29	42	48	53	33,6	370	145	65	6	M6	17	0,5	PHF FX50-22X47
24	50	26	29	42	48	56	33,6	400	140	60	6	M6	17	0,5	PHF FX50-24X50
25	50	26	29	42	48	56	33,6	420	125	60	6	M6	17	0,5	PHF FX50-25X50
28	55	26	29	42	48	61	33,6	470	110	60	6	M6	17	0,6	PHF FX50-28X55
30	55	26	29	42	48	61	33,6	510	105	60	6	M6	17	0,6	PHF FX50-30X55
32	60	26	29	42	48	66	51	810	145	80	9	M6	17	0,7	PHF FX50-32X60
35	60	26	29	42	48	66	51	890	135	80	9	M6	17	0,6	PHF FX50-35X60
38	65	26	29	42	48	71	51	970	125	70	9	M6	17	0,8	PHF FX50-38X65
40	65	26	29	42	48	71	51	1 020	120	70	9	M6	17	0,6	PHF FX50-40X65
42	75	30	34,4	51	59	81	62,8	1 320	135	75	6	M8	41	1,2	PHF FX50-42X75
45	75	30	34,4	51	59	81	62,8	1 410	125	75	6	M8	41	1,1	PHF FX50-45X75
48	80	30	34,4	51	59	86	62,8	1 510	120	70	6	M8	41	1,3	PHF FX50-48X80
50	80	30	34,4	51	59	86	62,8	1 570	110	70	6	M8	41	1,1	PHF FX50-50X80
55	85	30	34,4	51	59	91	94,6	2 600	150	100	9	M8	41	1,2	PHF FX50-55X85
60	90	30	34,4	51	59	96	94,6	2 830	140	95	9	M8	41	1,3	PHF FX50-60X90
65	95	30	34,4	51	59	102	94,6	3 070	130	90	9	M8	41	1,4	PHF FX50-65X95
70	110	40	45	56	66	117	116	4 000	110	70	7	M10	83	2,5	PHF FX50-70X110
75	115	40	45	56	66	122	116	4 300	100	65	7	M10	83	2,6	PHF FX50-75X115
80	120	40	45	56	66	127	116	4 600	100	65	7	M10	83	2,8	PHF FX50-80X120
85	125	40	45	56	66	132	133	5 600	105	70	8	M10	83	2,8	PHF FX50-85X125
90	130	40	45	56	66	137	133	6 000	100	70	8	M10	83	3	PHF FX50-90X130
95	135	40	45	56	66	142	166,8	7 900	115	80	10	M10	83	3	PHF FX50-95X135
100	145	46	52	65	77	153	169	8 470	100	65	7	M12	145	5,5	PHF FX50-100X145
110	155	46	52	65	77	163	169	9 200	90	65	7	M12	145	4,8	PHF FX50-110X155
120	165	46	52	65	77	173	193	11 600	90	70	8	M12	145	5,5	PHF FX50-120X165
130	180	46	52	65	77	188	242	15 700	110	80	10	M12	145	6	PHF FX50-130X180
140	190	51	58,5	73,5	87,5	199	366	25 300	135	100	11	M14	230	7,5	PHF FX50-140X190



**FX51**  
d 20 – 200 mm

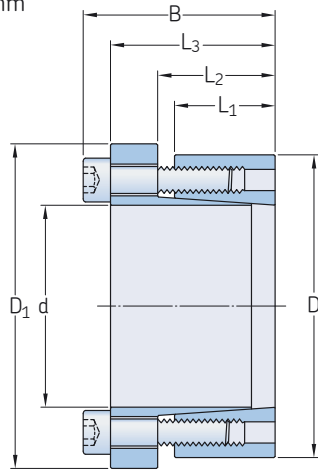

Dimensions			Performance		Pressure		Clamp screws		Weight	Designation					
d	D	L <sub>1</sub>	L <sub>2</sub>	L <sub>3</sub>	B	D <sub>1</sub>	Transmissible axial force F <sub>t</sub>	Transmissible torque M <sub>t</sub>	Shaft surface P <sub>w</sub>	Hub surface P <sub>n</sub>	Qty	Size	Tightening torque M <sub>s</sub>	kg	
mm							kN	Nm	N/mm <sup>2</sup>	N/mm <sup>2</sup>	–	–	Nm	kg	–
20	47	17	22	28	34	56	0,28	28 000	220	95	5	M6	17	0,3	PHF FX51-20X47
22	47	17	22	28	34	56	0,3	28 000	200	95	5	M6	17	0,3	PHF FX51-22X47
24	50	17	22	28	34	59	0,33	28 000	180	90	5	M6	17	0,3	PHF FX51-24X50
25	50	17	22	28	34	59	0,42	34 000	210	105	6	M6	17	0,3	PHF FX51-25X50
28	55	17	22	28	34	64	0,47	34 000	190	95	6	M6	17	0,4	PHF FX51-28X55
30	55	17	22	28	34	64	0,5	34 000	175	95	6	M6	17	0,4	PHF FX51-30X55
32	60	17	22	28	34	69	0,72	45 000	220	115	8	M6	17	0,4	PHF FX51-32X60
35	60	17	22	28	34	69	0,79	45 000	200	115	8	M6	17	0,4	PHF FX51-35X60
38	65	17	22	28	34	74	0,85	45 000	185	105	8	M6	17	0,5	PHF FX51-38X65
40	65	17	22	28	34	74	0,9	45 000	175	105	8	M6	17	0,5	PHF FX51-40X65
42	75	20	25	33	41	84	1,53	73 000	225	125	7	M8	41	0,8	PHF FX51-42X75
45	75	20	25	33	41	84	1,65	73 000	215	125	7	M8	41	0,7	PHF FX51-45X75
48	80	20	25	33	41	89	1,76	73 000	200	120	7	M8	41	0,8	PHF FX51-48X80
50	80	20	25	33	41	89	1,83	73 000	195	120	7	M8	41	0,8	PHF FX51-50X80
55	85	20	25	33	41	94	2,3	83 500	200	130	8	M8	41	0,9	PHF FX51-55X85
60	90	20	25	33	41	99	2,51	83 500	185	125	8	M8	41	0,9	PHF FX51-60X90
65	95	20	25	33	41	104	3,06	94 000	190	130	9	M8	41	1	PHF FX51-65X95
70	110	24	30	40	50	119	4,67	133 000	210	135	8	M10	83	1,9	PHF FX51-70X110
75	115	24	30	40	50	124	5	133 000	195	125	8	M10	83	2	PHF FX51-75X115
80	120	24	30	40	50	129	5,3	133 000	185	125	8	M10	83	2	PHF FX51-80X120
85	125	24	30	40	50	134	6,3	148 000	195	135	9	M10	83	2	PHF FX51-85X125
90	130	24	30	40	50	139	6,75	148 000	185	130	9	M10	83	2,2	PHF FX51-90X130
95	135	24	30	40	50	144	7,9	166 000	195	135	10	M10	83	2,3	PHF FX51-95X135
100	145	26	32	44	56	154	9,7	194 000	200	140	8	M12	145	3	PHF FX51-100X145
110	155	26	32	44	56	164	10,6	194 000	180	130	8	M12	145	3,2	PHF FX51-110X155
120	165	26	32	44	56	174	13	216 000	185	135	9	M12	145	3,4	PHF FX51-120X165
130	180	34	40	54	64	189	18,9	290 000	175	125	12	M12	145	5,2	PHF FX51-130X180
140	190	34	40	54	68	199	20,5	290 000	165	120	9	M14	230	5,4	PHF FX51-140X190
150	200	34	40	54	68	209	25	333 000	175	130	10	M14	230	5,7	PHF FX51-150X200
160	210	34	40	54	68	219	29	362 000	180	135	11	M14	230	6	PHF FX51-160X210
170	225	44	50	64	78	234	34	400 000	140	105	12	M14	230	8,3	PHF FX51-170X225
180	235	44	50	64	78	244	36	400 000	135	105	12	M14	230	8,8	PHF FX51-180X235
190	250	44	50	64	78	259	47,5	500 000	160	120	15	M14	230	10	PHF FX51-190X250
200	260	44	50	64	78	269	50	500 000	150	115	15	M14	230	10,5	PHF FX51-200X260

**FX52**

d 14 – 50 mm

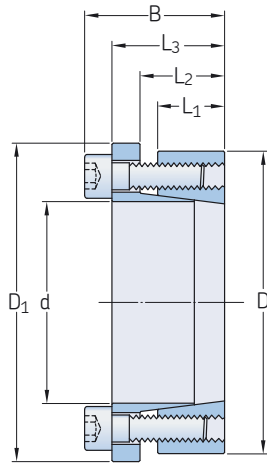

Dimensions							Performance		Pressure		Clamp screws		Weight	Designation	
d	D	L <sub>1</sub>	L <sub>2</sub>	L <sub>3</sub>	B	D <sub>1</sub>	Transmissible axial force F <sub>t</sub>	Transmissible torque M <sub>t</sub>	Shaft surface P <sub>w</sub>	Hub surface P <sub>n</sub>	Qty	Size	Tightening torque M <sub>s</sub>	kg	–
mm							kN	Nm	N/mm <sup>2</sup>	N/mm <sup>2</sup>	–	–	Nm	kg	–
14	55	17	22	30	38	62	18,1	120	205	55	3	M8	25	0,5	PHF FX52-14X55
16	55	17	22	30	38	62	18,1	140	180	55	3	M8	25	0,5	PHF FX52-16X55
18	55	17	22	30	38	62	18,1	150	160	55	3	M8	25	0,5	PHF FX52-18X55
19	55	17	22	30	38	62	18,1	160	150	55	3	M8	25	0,5	PHF FX52-19X55
20	55	17	22	30	38	62	18,1	170	145	55	3	M8	25	0,5	PHF FX52-20X55
22	55	17	22	30	38	62	25,3	280	185	75	3	M8	35	0,5	PHF FX52-22X55
24	55	17	22	30	38	62	25,3	300	170	75	3	M8	35	0,5	PHF FX52-24X55
25	55	17	22	30	38	62	25,3	310	165	75	3	M8	35	0,5	PHF FX52-25X55
28	55	17	22	30	38	62	31,4	430	175	90	3	M8	41	0,4	PHF FX52-28X55
30	55	17	22	30	38	62	31,4	470	165	90	3	M8	41	0,4	PHF FX52-30X55
24	65	17	22	30	38	72	37,4	440	245	90	5	M8	30	0,7	PHF FX52-24X65
25	65	17	22	30	38	72	37,4	460	235	90	5	M8	30	0,7	PHF FX52-25X65
28	65	17	22	30	38	72	43,6	600	245	105	5	M8	35	0,6	PHF FX52-28X65
30	65	17	22	30	38	72	43,6	640	230	105	5	M8	35	0,6	PHF FX52-30X65
32	65	17	22	30	38	72	43,6	690	215	105	5	M8	35	0,6	PHF FX52-32X65
35	65	17	22	30	38	72	52,5	910	235	130	5	M8	41	0,5	PHF FX52-35X65
38	65	17	22	30	38	72	52,5	990	220	130	5	M8	41	0,5	PHF FX52-38X65
40	65	17	22	30	38	72	52,5	1 050	205	130	5	M8	41	0,5	PHF FX52-40X65
30	80	20	25	33	41	87	52,4	780	235	90	7	M8	30	1	PHF FX52-30X80
32	80	20	25	33	41	87	52,4	830	220	90	7	M8	30	1	PHF FX52-32X80
35	80	20	25	33	41	87	61	1 060	230	100	7	M8	35	1	PHF FX52-35X80
38	80	20	25	33	41	87	61	1 150	215	100	7	M8	35	1	PHF FX52-38X80
40	80	20	25	33	41	87	61	1 220	205	100	7	M8	35	0,9	PHF FX52-40X80
42	80	20	25	33	41	87	73,5	1 540	235	120	7	M8	41	0,9	PHF FX52-42X80
45	80	20	25	33	41	87	73,5	1 650	220	120	7	M8	41	0,8	PHF FX52-45X80
48	80	20	25	33	41	87	73,5	1 760	205	120	7	M8	41	0,8	PHF FX52-48X80
50	80	20	25	33	41	87	73,5	1 830	195	120	7	M8	41	0,8	PHF FX52-50X80

**FX60**

d 25 – 400 mm

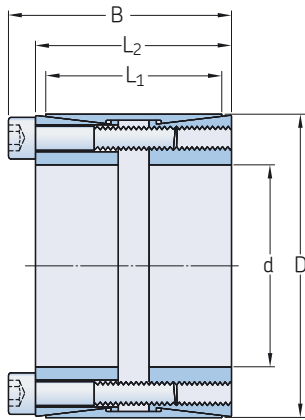

Dimensions					Performance	Transmissible	Pressure		Clamp screws		Weight	Designation	
d	D	L <sub>1</sub>	L <sub>2</sub>	B	Transmissible axial force F <sub>t</sub>	torque M <sub>t</sub>	Shaft surface P <sub>w</sub>	Hub surface P <sub>n</sub>	Qty	Size	Tightening torque M <sub>s</sub>		
mm					kN	Nm	N/mm <sup>2</sup>	N/mm <sup>2</sup>	–	–	Nm	kg	–
25	50	39	45	51	76	950	245	122	8	M6	17	0,5	PHF FX60-25X50
28	55	39	45	51	76	1 070	219	111	8	M6	17	0,6	PHF FX60-28X55
30	55	39	45	51	76	1 150	204	111	8	M6	17	0,6	PHF FX60-30X55
35	60	39	45	51	76	1 340	175	102	8	M6	17	0,7	PHF FX60-35X60
38	65	39	45	51	76	1 450	161	94	8	M6	17	0,7	PHF FX60-38X65
40	65	39	45	51	76	1 530	153	94	8	M6	17	0,7	PHF FX60-40X65
42	75	56	64	72	141	2 970	188	105	8	M8	41	1	PHF FX60-42X75
45	75	56	64	72	141	3 150	175	105	8	M8	41	0,9	PHF FX60-45X75
48	80	56	64	72	166	4 000	164	98	8	M8	41	1,4	PHF FX60-48X80
50	80	56	64	72	166	4 150	158	98	8	M8	41	1,3	PHF FX60-50X80
55	85	56	64	72	166	4 550	143	93	8	M8	41	1,5	PHF FX60-55X85
60	90	56	64	72	207	6 200	164	109	10	M8	41	1,6	PHF FX60-60X90
65	95	56	64	72	207	6 750	152	104	10	M8	41	1,8	PHF FX60-65X95
70	110	70	78	88	330	11 550	179	114	10	M10	83	3	PHF FX60-70X110
75	115	70	78	88	330	12 350	167	109	10	M10	83	3,3	PHF FX60-75X115
80	120	70	78	88	396	15 800	188	125	12	M10	83	3,5	PHF FX60-80X120
85	125	70	78	88	396	16 800	177	120	12	M10	83	3,7	PHF FX60-85X125
90	130	70	78	88	396	17 800	167	115	12	M10	83	3,8	PHF FX60-90X130
95	135	70	78	88	396	18 800	158	111	12	M10	83	5	PHF FX60-95X135
100	145	90	100	112	576	28 800	170	117	12	M12	145	6	PHF FX60-100X145
110	155	90	100	112	576	31 700	155	110	12	M12	145	6,2	PHF FX60-110X155
120	165	90	100	112	573	40 300	165	120	14	M12	145	7,2	PHF FX60-120X165
130	180	104	116	130	791	51 400	155	112	12	M14	230	10	PHF FX60-130X180
140	190	104	116	130	923	64 600	168	124	14	M14	230	10,2	PHF FX60-140X190
150	200	104	116	130	1 055	79 100	179	135	16	M14	230	10,8	PHF FX60-150X200
160	210	104	116	130	1 055	84 400	168	128	16	M14	230	11,5	PHF FX60-160X210
170	225	134	146	162	1 283	109 000	149	113	14	M16	355	17	PHF FX60-170X225
180	235	134	146	162	1 466	132 000	161	124	16	M16	355	18,5	PHF FX60-180X235
190	250	134	146	162	1 466	139 000	153	116	16	M16	355	21,5	PHF FX60-190X250
200	260	134	146	162	1 466	146 500	145	112	16	M16	355	22	PHF FX60-200X260
220	285	134	146	162	1 833	201 500	165	127	20	M16	355	25	PHF FX60-220X285
240	305	134	146	162	2 017	242 000	166	131	22	M16	355	27	PHF FX60-240X305
260	325	134	146	162	2 017	262 000	154	123	22	M16	355	30	PHF FX60-260X325
280	355	165	177	197	2 862	400 000	164	130	20	M20	690	46	PHF FX60-280X355
300	375	165	177	197	3 148	472 000	169	135	22	M20	690	50	PHF FX60-300X375
320	405	165	177	197	3 148	503 500	158	125	22	M20	690	60	PHF FX60-320X405
340	425	165	177	197	3 434	583 500	162	130	24	M20	690	65	PHF FX60-340X425
360	455	190	202	224	3 918	705 000	152	120	22	M22	930	89	PHF FX60-360X455
380	475	190	202	224	4 631	880 000	170	136	26	M22	930	93	PHF FX60-380X475
400	495	190	202	224	4 631	926 000	162	131	26	M22	930	98	PHF FX60-400X495

**FX80**

d 14 – 70 mm

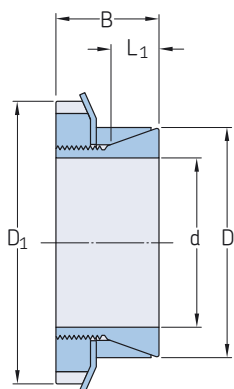

Dimensions					Performance		Pressure		Clamp screws		Weight	Designation
d	D	L <sub>1</sub>	B	D <sub>1</sub>	Transmissible axial force F <sub>t</sub>	Transmissible torque M <sub>t</sub>	Shaft surface P <sub>w</sub>	Hub surface P <sub>n</sub>	Nut size	Tightening torque M <sub>s</sub>	kg	–
mm					kN	Nm	N/mm <sup>2</sup>	N/mm <sup>2</sup>	–	Nm	kg	–
14	25	6,5	16,5	32	5,1	38	200	110	KM4	95	0,05	PHF FX80-14X25
15	25	6,5	16,5	32	5,5	41	185	110	KM4	95	0,05	PHF FX80-15X25
16	25	6,5	16,5	32	5,45	43	174	110	KM4	95	0,04	PHF FX80-16X25
17	26	6,5	16,5	32	5,5	47	164	107	KM4	95	0,04	PHF FX80-17X26
18	26	6,5	16,5	32	5,4	49	155	107	KM4	95	0,04	PHF FX80-18X26
19	30	6,5	18	38	6,6	62	176	112	KM5	160	0,08	PHF FX80-19X30
20	30	6,5	18	38	6,6	66	167	111	KM5	160	0,07	PHF FX80-20X30
22	32	6,5	18	38	6,6	73	152	105	KM5	160	0,1	PHF FX80-22X32
24	35	6,5	18	45	8,75	105	185	127	KM6	220	0,09	PHF FX80-24X35
25	35	6,5	18	45	8,8	110	178	127	KM6	220	0,09	PHF FX80-25X35
28	36	6,5	18	45	8,55	120	159	124	KM6	220	0,07	PHF FX80-28X36
30	40	7	19,5	52	10,6	160	164	123	KM7	340	0,07	PHF FX80-30X40
32	42	7	19,5	52	10,6	170	154	117	KM7	340	0,17	PHF FX80-32X42
35	45	8	21,5	58	13,1	230	153	120	KM8	480	0,17	PHF FX80-35X45
36	45	8	21,5	58	13,3	240	149	120	KM8	480	0,15	PHF FX80-36X45
38	48	8	21,5	58	13,1	250	141	112	KM8	480	0,15	PHF FX80-38X48
40	52	10	24,5	65	15,5	310	120	93	KM9	680	0,24	PHF FX80-40X52
42	55	10	25,5	65	15,2	320	114	87	KM9	680	0,25	PHF FX80-42X55
45	57	10	25,5	70	17,7	400	122	96	KM10	870	0,28	PHF FX80-45X57
48	62	10	25,5	75	20,8	500	135	105	KM11	970	0,32	PHF FX80-48X62
50	62	10	25,5	75	20,8	520	130	105	KM11	970	0,3	PHF FX80-50X62
55	68	12	27,5	80	22	610	103	84	KM12	1 100	0,36	PHF FX80-55X68
56	68	12	27,5	80	22	620	101	82	KM12	1 100	0,34	PHF FX80-56X68
60	73	12	28,5	85	26,6	800	113	93	KM13	1 300	0,4	PHF FX80-60X73
63	79	14	30,5	92	31,1	980	107	86	KM14	1 600	0,56	PHF FX80-63X79
65	79	14	30,5	92	31,1	1 010	104	86	KM14	1 600	0,52	PHF FX80-65X79
70	84	14	31,5	98	35,4	1 240	110	92	KM15	2 000	0,6	PHF FX80-70X84

**FX90**  
d 14 – 60 mm

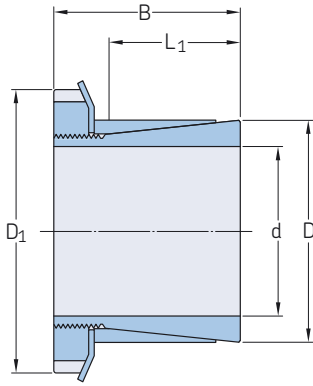

Dimensions					Performance		Pressure		Clamp screws		Weight	Designation
d	D	L	B	D <sub>1</sub>	Transmissible axial force F <sub>t</sub>	Transmissible torque M <sub>t</sub>	Shaft surface P <sub>w</sub>	Hub surface P <sub>n</sub>	Nut size	Tightening torque M <sub>s</sub>	kg	–
mm					kN	Nm	N/mm <sup>2</sup>	N/mm <sup>2</sup>	–	Nm	kg	–
14	25	20	30	32	9	64	85	45	KM4	95	0,08	PHF FX90-14X25
15	25	20	30	32	9	70	80	45	KM4	95	0,08	PHF FX90-15X25
16	25	20	30	32	9	73	75	45	KM4	95	0,07	PHF FX90-16X25
17	25	20	32	32	9	80	70	45	KM4	160	0,07	PHF FX90-17X25
18	30	20	32	38	9	83	65	40	KM4	160	0,12	PHF FX90-18X30
19	30	20	32	38	11	105	75	45	KM5	160	0,12	PHF FX90-19X30
20	30	20	32	38	11	112	70	45	KM5	160	0,11	PHF FX90-20X30
22	35	25	36	45	14	163	70	45	KM6	220	0,18	PHF FX90-22X35
24	35	25	36	45	14	178	65	45	KM6	220	0,16	PHF FX90-24X35
25	35	25	36	45	14	185	60	45	KM6	220	0,15	PHF FX90-25X35
28	40	30	42	52	17	250	55	40	KM7	340	0,24	PHF FX90-28X40
30	40	30	42	52	17	270	50	40	KM7	340	0,21	PHF FX90-30X40
32	45	30	44	58	21	350	60	45	KM8	480	0,32	PHF FX90-32X45
35	45	30	44	58	21	390	55	45	KM8	480	0,26	PHF FX90-35X45
38	50	30	45	65	26	500	60	45	KM9	680	0,35	PHF FX90-38X50
40	50	30	45	65	26	520	55	45	KM9	680	0,33	PHF FX90-40X50
42	55	30	46	70	30	680	60	50	KM10	870	0,43	PHF FX90-42X55
45	55	30	46	70	30	680	60	50	KM10	870	0,39	PHF FX90-45X55
48	60	30	46	75	35	840	60	50	KM11	970	0,45	PHF FX90-48X60
50	60	30	46	75	35	880	60	50	KM11	970	0,4	PHF FX90-50X60
55	65	30	46	80	37	1 030	60	50	KM12	1 100	0,44	PHF FX90-55X65
60	70	30	52	85	45	1 360	65	55	KM13	1 300	0,55	PHF FX90-60X70

**FX120**

d 18 – 80 mm

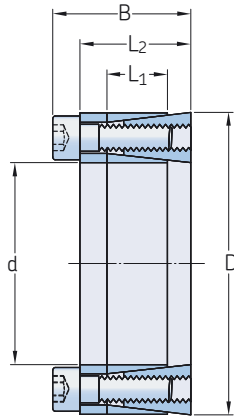

Dimensions					Performance Transmissible torque $M_t$	Pressure Shaft surface $P_w$	Hub surface $P_n$	Clamp screws			Weight	Designation
d	D	$L_1$	$L_2$	B				Qty	Size	Tightening torque $M_s$		
mm					Nm	N/mm <sup>2</sup>	N/mm <sup>2</sup>	-	-	Nm	kg	-
18	40	12	18,5	24,5	190	260	120	6	M6	16	0,12	PHF FX120-18X40
19	41	12	18,5	24,5	210	260	120	6	M6	16	0,13	PHF FX120-19X41
20	42	12	18,5	24,5	240	250	120	6	M6	16	0,13	PHF FX120-20X42
24	46	12	18,5	24,5	290	250	120	6	M6	16	0,15	PHF FX120-24X46
25	47	12	18,5	24,5	330	230	120	8	M6	16	0,16	PHF FX120-25X47
28	50	12	18,5	24,5	370	220	120	8	M6	16	0,17	PHF FX120-28X50
30	52	12	18,5	24,5	430	210	120	8	M6	16	0,18	PHF FX120-30X52
35	57	15	22,0	28,0	610	170	100	12	M6	16	0,24	PHF FX120-35X57
38	60	15	22,0	28,0	680	170	100	12	M6	16	0,26	PHF FX120-38X60
40	62	15	22,0	28,0	780	170	100	12	M6	16	0,27	PHF FX120-40X62
42	70	18	28,0	36,0	1 480	190	110	12	M8	41	0,50	PHF FX120-42X70
45	73	18	28,0	36,0	1 500	210	130	12	M8	41	0,51	PHF FX120-45X73
48	76	18	28,0	36,0	1 550	210	130	12	M8	41	0,55	PHF FX120-48X76
50	78	18	28,0	36,0	1 650	190	120	12	M8	41	0,57	PHF FX120-50X78
55	83	18	28,0	36,0	2 000	190	120	16	M8	41	0,64	PHF FX120-55X83
60	88	18	28,0	36,0	2 350	190	120	16	M8	41	0,67	PHF FX120-60X88
70	105	22	35,0	45,0	3 900	180	120	12	M10	70	1,19	PHF FX120-70X105
80	115	22	35,0	45,0	4 800	170	120	16	M10	70	1,32	PHF FX120-80X115

**FX130**  
d 17 – 80 mm

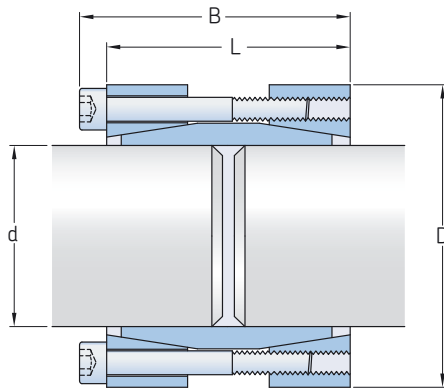

Standard

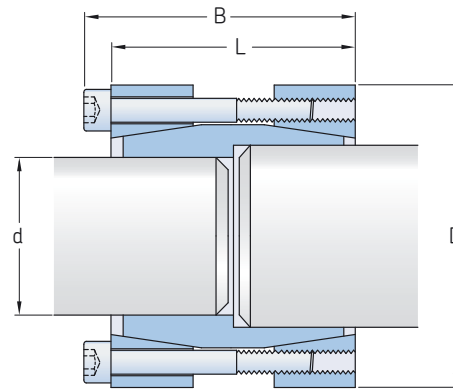

Double diameter\*

Dimensions				Performance		Clamp screws		Tightening torque $M_s$	Weight	Designation
d	D	L	B	Transmissible axial force $F_t$	Transmissible torque $M_t$	Qty	Size			
mm				kN	Nm	–	–	Nm	kg	–
17	50	50	56	24,5	210	4	M6	17	0,5	PHF FX130-17X50
18	50	50	56	24,5	230	4	M6	17	0,5	PHF FX130-18X50
19	50	50	56	24,5	240	4	M6	17	0,5	PHF FX130-19X50
20	50	50	56	24,5	250	4	M6	17	0,5	PHF FX130-20X50
22	55	60	66	24,5	270	4	M6	17	0,6	PHF FX130-22X55
24	55	60	66	24,5	300	4	M6	17	0,6	PHF FX130-24X55
25	55	60	66	36,5	460	6	M6	17	0,6	PHF FX130-25X55
28	60	60	66	36,5	520	6	M6	17	0,7	PHF FX130-28X60
30	60	60	66	36,5	560	6	M6	17	0,7	PHF FX130-30X60
32	63	60	66	36,5	590	6	M6	17	0,7	PHF FX130-32X63
35	75	75	83	45,5	770	4	M8	41	1,3	PHF FX130-35X75
38	75	75	83	45,5	860	4	M8	41	1,3	PHF FX130-38X75
40	75	75	83	45,5	910	4	M8	41	1,3	PHF FX130-40X75
42	78	75	83	45,5	940	4	M8	41	2	PHF FX130-42X78
45	85	85	93	67,5	1 530	6	M8	41	2,2	PHF FX130-45X85
48	90	85	93	67,5	1 610	6	M8	41	2,4	PHF FX130-48X90
50	90	85	93	67,5	1 700	6	M8	41	2,3	PHF FX130-50X90
55	94	85	93	90,5	2 460	8	M8	41	2,9	PHF FX130-55X94
60	100	85	93	90,5	2 720	8	M8	41	3,2	PHF FX130-60X100
65	105	85	93	90,5	2 940	8	M8	41	3	PHF FX130-65X105
70	115	100	110	107,5	3 780	6	M10	83	4,3	PHF FX130-70X115
75	125	100	110	107,5	4 040	6	M10	83	5	PHF FX130-75X125
80	125	100	110	107,5	4 300	6	M10	83	4,7	PHF FX130-80X125

\* Double diameter versions are available upon request: contact SKF for details.



**FX140**

d 18 – 90 mm

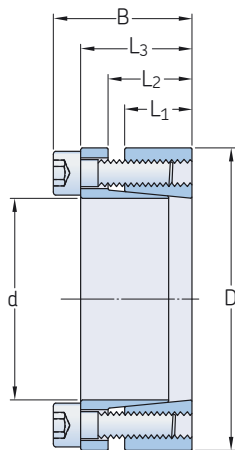

Dimensions						Performance		Pressure		Clamp screws			Weight	Designation
d	D	L <sub>1</sub>	L <sub>2</sub>	L <sub>3</sub>	B	Transmissible axial force F <sub>t</sub>	Transmissible torque M <sub>t</sub>	Shaft surface P <sub>w</sub>	Hub surface P <sub>n</sub>	Qty	Size	Tightening torque M <sub>s</sub>	kg	-
mm						kN	Nm	N/mm <sup>2</sup>	N/mm <sup>2</sup>	-	-	Nm	kg	-
18	40	12	15	20	24	23,7	210	235	130	6	M4	5	0,2	PHF FX140-18X40
19	41	12	15	20	24	23,7	220	220	128	6	M4	5	0,2	PHF FX140-19X41
20	42	12	15	20	24	27,7	270	245	145	7	M4	5	0,2	PHF FX140-20X42
22	44	12	15	20	24	27,7	300	225	140	7	M4	5	0,2	PHF FX140-22X44
24	46	12	15	20	24	27,7	330	205	135	7	M4	5	0,2	PHF FX140-24X46
25	47	12	15	20	24	27,7	340	195	130	7	M4	5	0,2	PHF FX140-25X47
28	50	12	15	20	24	35,6	500	225	155	9	M4	5	0,2	PHF FX140-28X50
30	52	12	15	20	24	35,6	530	210	151	9	M4	5	0,2	PHF FX140-30X52
32	54	12	15	20	24	35,6	570	197	146	9	M4	5	0,2	PHF FX140-32X54
35	57	16	19	24	28	39,5	690	158	115	10	M4	5	0,3	PHF FX140-35X57
36	58	16	19	24	28	39,5	710	155	113	10	M4	5	0,3	PHF FX140-36X58
38	60	16	19	24	28	43,5	830	160	120	11	M4	5	0,3	PHF FX140-38X60
40	62	16	19	24	28	43,5	870	150	116	11	M4	5	0,4	PHF FX140-40X62
42	70	19	23	30	36	73	1 530	200	146	8	M6	17	0,6	PHF FX140-42X70
45	73	19	23	30	36	73	1 640	185	140	8	M6	17	0,6	PHF FX140-45X73
48	76	19	23	30	36	73	1 750	175	134	8	M6	17	0,6	PHF FX140-48X76
50	78	19	23	30	36	73	1 820	165	131	8	M6	17	0,6	PHF FX140-50X78
55	83	19	23	30	36	73	2 000	150	123	8	M6	17	0,7	PHF FX140-55X83
56	84	19	23	30	36	73	2 040	150	120	8	M6	17	0,7	PHF FX140-56X84
60	88	19	23	30	36	82,1	2 460	158	130	9	M6	17	0,7	PHF FX140-60X88
63	91	19	23	30	36	82,1	2 580	150	125	9	M6	17	0,9	PHF FX140-63X91
65	93	19	23	30	36	82,1	2 660	140	120	9	M6	17	1	PHF FX140-65X93
70	105	23	28	37	45	134,8	4 720	180	148	8	M8	41	1,5	PHF FX140-70X105
75	110	23	28	37	45	134,8	5 050	170	140	8	M8	41	1,5	PHF FX140-75X110
80	115	23	28	37	45	134,8	5 390	160	135	8	M8	41	1,7	PHF FX140-80X115
85	120	23	28	37	45	134,8	5 730	150	130	8	M8	41	2	PHF FX140-85X120
90	125	23	28	37	45	168,5	7 580	156	156	10	M8	41	2,3	PHF FX140-90X125

**FX190**

d 14 – 170 mm

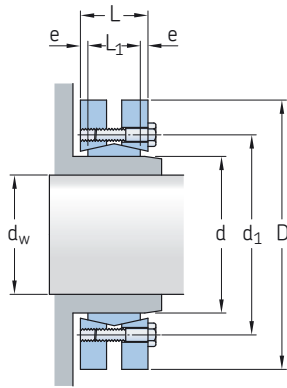

Dimensions			Performance		Clamp screws		Tightening torque $M_s$	Weight	Designation				
d	$d_w$	D	$L_1$	L	$d_1$	e				Transmissible axial force $F_t$	Transmissible torque $M_t$	Qty	Size
mm							kN	Nm	-	-	Nm	kg	-
<b>14</b>	11 12	38	7	11,0	23	2	6 9	30 50	4	M5	4	0,1	<b>PHF FX190-14X38</b>
<b>16</b>	13 14	41	11	15,0	26	2	10 13	70 90	5	M5	4	0,1	<b>PHF FX190-16X41</b>
<b>24</b>	19 20 21	50	14	19,5	36	2,75	25 27 29	170 210 250	6	M5	4	0,2	<b>PHF FX190-24X50</b>
<b>30</b>	24 25 26	60	16	21,5	44	2,75	29 31 33	300 340 380	7	M5	4	0,3	<b>PHF FX190-30X60</b>
<b>36</b>	28 30 31	72	18	23,5	52	2,75	50 58 58	440 570 630	5	M6	12	0,4	<b>PHF FX190-36X72</b>
<b>44</b>	32 35 36	80	20	25,5	61	2,75	64 74 77	620 780 860	7	M6	12	0,6	<b>PHF FX190-44X80</b>
<b>50</b>	38 40 42	90	22	27,5	70	2,75	79 86 92	940 1 160 1 380	8	M6	12	0,8	<b>PHF FX190-50X90</b>
<b>55</b>	42 45 48	100	23	30,5	75	3,75	79 88 97	1 160 1 520 1 880	8	M6	12	1,1	<b>PHF FX190-55X100</b>
<b>62</b>	48 50 52	110	23	30,5	86	3,75	100 111 117	1 850 2 200 2 400	10	M6	12	1,3	<b>PHF FX190-62X110</b>
<b>68</b>	50 55 60	115	23	30,5	86	3,75	97 106 120	2 000 2 500 3 150	10	M6	12	1,4	<b>PHF FX190-68X115</b>
<b>75</b>	55 60 65	138	25	32,5	100	3,75	119 137 155	2 500 3 200 3 950	7	M8	30	1,7	<b>PHF FX190-75X138</b>
<b>80</b>	60 65 70	145	25	32,5	100	3,75	124 140 158	3 200 3 900 4 600	7	M8	30	1,9	<b>PHF FX190-80X145</b>
<b>85</b>	65 70 75	155	30	39,0	114	4,5	175 195 216	4 800 6 100 7 400	10	M8	30	3,5	<b>PHF FX190-85X155</b>

Dimensions							Performance		Clamp screws		Weight	Designation	
d	d <sub>w</sub>	D	L <sub>1</sub>	L	d <sub>1</sub>	e	Transmissible axial force F <sub>t</sub>	Transmissible torque M <sub>t</sub>	Qty	Size	Tightening torque M <sub>s</sub>	kg	–
mm							kN	Nm	–	–	Nm	kg	–
<b>90</b>	65 70 75	155	30	39,0	114	4,5	170 190 210	4 750 6 000 7 250	10	M8	30	3,3	<b>PHF FX190-90X155</b>
<b>100</b>	70 75 80	170	34	44,0	124	5	195 220 240	6 900 7 500 9 000	12	M8	30	4,7	<b>PHF FX190-100X170</b>
<b>110</b>	75 80 85	185	39	50,0	136	5,5	229 252 262	7 200 9 000 10 800	9	M10	59	5,9	<b>PHF FX190-110X185</b>
<b>115</b>	80 85 90	188	39	50,0	141	5,5	235 259 269	7 400 9 200 11 100	9	M10	59	5,5	<b>PHF FX190-115X188</b>
<b>120</b>	80 85 90	215	42	54,0	160	6	285 314 340	10 600 13 300 14 500	12	M10	59	9	<b>PHF FX190-120X215</b>
<b>125</b>	85 90 95	215	42	54,0	160	6	296 324 352	11 000 13 000 15 000	12	M10	59	8,3	<b>PHF FX190-125X215</b>
<b>130</b>	90 95 100	215	42	54,0	160	6	304 333 362	11 300 13 300 15 400	12	M10	59	8	<b>PHF FX190-130X215</b>
<b>140</b>	95 100 105	230	46	60,5	175	7,25	367 396 425	15 100 17 600 20 100	10	M12	100	10	<b>PHF FX190-140X230</b>
<b>155</b>	105 110 115	265	50	64,5	192	7,25	447 478 509	22 000 25 000 28 000	12	M12	100	15	<b>PHF FX190-155X265</b>
<b>160</b>	110 115 120	265	50	64,5	192	7,25	460 490 520	22 600 25 700 28 800	12	M12	100	14,5	<b>PHF FX190-160X265</b>
<b>165</b>	115 120 125	290	56	71,0	210	7,5	595 630 655	31 000 35 000 39 000	8	M16	250	22	<b>PHF FX190-165X290</b>
<b>170</b>	120 125 130	290	56	71,0	210	7,5	610 640 670	31 900 36 000 40 100	8	M16	250	21	<b>PHF FX190-170X290</b>

**FX190**

d 175 – 480 mm

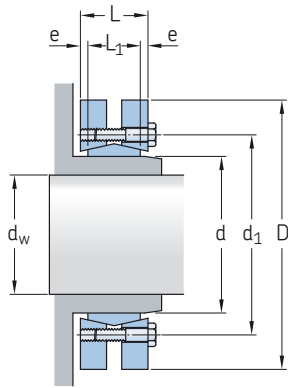

Dimensions							Performance		Clamp screws		Tightening torque	Weight	Designation
d	d <sub>w</sub>	D	L <sub>1</sub>	L	d <sub>1</sub>	e	Transmissible axial force F <sub>t</sub>	Transmissible torque M <sub>t</sub>	Qty	Size	M <sub>s</sub>	kg	-
mm							kN	Nm	-	-	Nm	kg	-
<b>175</b>	125 130 135	300	56	71,0	220	7,5	605 369 675	36 000 41 000 45 000	8	M16	250	22	<b>PHF FX190-175X300</b>
<b>180</b>	130 135 140	330	71	86,0	236	7,5	778 819 861	52 000 57 000 62 000	8	M16	250	21	<b>PHF FX190-180X330</b>
<b>185</b>	135 140 145	330	71	86,0	236	7,5	778 819 861	52 000 57 000 62 000	10	M24	250	37	<b>PHF FX190-185X330</b>
<b>190</b>	140 145 150	330	71	86,0	236	7,5	800 840 885	63 500 58 700 63 800	10	M16	250	36	<b>PHF FX190-190X330</b>
<b>195</b>	140 150 155	350	71	86,0	246	7,5	933 1 025 1 071	65 000 76 000 81 500	12	M16	250	41	<b>PHF FX190-195X350</b>
<b>200</b>	150 155 160	350	71	86,0	246	7,5	990 1 035 1 080	74 000 80 000 86 000	12	M16	250	41	<b>PHF FX190-200X350</b>
<b>220</b>	160 165 170	370	88	104,0	270	8	1 190 1 239 1 290	95 000 102 000 110 000	15	M16	250	54	<b>PHF FX190-220X370</b>
<b>240</b>	170 180 190	405	92	109	295	8,5	1 464 1 576 1 675	120 000 138 000 156 000	12	M20	490	67	<b>PHF FX190-240X405</b>
<b>260</b>	190 200 210	430	103	120	321	8,5	1 760 1 880 2 010	164 000 184 000 205 000	14	M20	490	82	<b>PHF FX190-260X430</b>
<b>280</b>	210 220 230	460	114	134	346	10	2 090 2 220 2 350	217 000 244 000 270 000	16	M20	490	102	<b>PHF FX190-280X460</b>
<b>300</b>	230 240 245	485	122	142	364	10	2 431 2 567 2 636	275 000 295 000 315 000	18	M20	490	118	<b>PHF FX190-300X485</b>
<b>320</b>	240 250 260	520	122	142	386	10	2 647 2 786 2 900	312 000 340 000 374 000	20	M20	490	131	<b>PHF FX190-320X520</b>

Dimensions							Performance		Clamp screws		Weight	Designation	
d	d <sub>w</sub>	D	L <sub>1</sub>	L	d <sub>1</sub>	e	Transmissible axial force F <sub>t</sub>	Transmissible torque M <sub>t</sub>	Qty	Size	Tightening torque M <sub>s</sub>	kg	–
mm							kN	Nm	–	–	Nm	kg	–
<b>340</b>	250 260 270	570	134	156	408	11	3 119 3 249 3 400	390 000 422 500 460 000	24	M20	490	186	<b>PHF FX190-340X570</b>
<b>350</b>	270 280 285	580	140	162	432	11	3 276 3 430 3 500	442 000 480 000 500 000	24	M20	490	195	<b>PHF FX190-350X580</b>
<b>360</b>	280 290 295	590	140	162	432	11	3 310 3 461 3 536	463 000 502 000 522 000	24	M20	490	204	<b>PHF FX190-360X590</b>
<b>380</b>	290 300 310	645	144	168	458	12	3 910 4 080 4 248	567 000 610 000 658 000	20	M24	840	239	<b>PHF FX190-380X645</b>
<b>390</b>	300 310 320	660	144	168	468	12	4 160 4 330 4 484	624 000 671 000 718 000	21	M24	840	260	<b>PHF FX190-390X660</b>
<b>400</b>	315 320 330	680	144	168	480	12	4 260 4 345 4 500	670 000 695 000 744 000	21	M24	840	280	<b>PHF FX190-400X680</b>
<b>420</b>	330 340 350	690	164	188	504	12	4 850 5 040 5 220	780 000 840 000 900 000	24	M24	840	316	<b>PHF FX190-420X690</b>
<b>440</b>	340 350 360	750	177	202	527	12,5	4 740 4 910 5 090	806 000 860 000 917 000	24	M24	840	408	<b>PHF FX190-440X750</b>
<b>460</b>	360 370 380	770	177	202	547	12,5	5 670 5 860 6 050	1 000 000 1 070 000 1 140 000	28	M24	840	420	<b>PHF FX190-460X770</b>
<b>480</b>	380 390 400	800	188	213	570	12,5	6 150 6 350 6 550	1 170 000 1 240 000 1 310 000	30	M24	840	505	<b>PHF FX190-480X800</b>

**FX350**  
d 10 – 25 mm

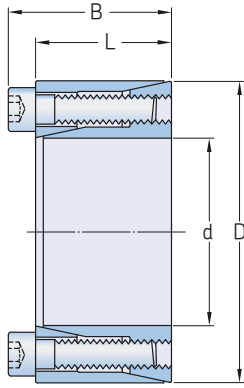

Dimensions				Performance Transmissible torque $M_t$	Pressure Shaft surface $P_w$	Hub surface $P_n$	Clamp screws			Weight	Designation
d	D	L	B				Qty	Size	Tightening torque $M_s$		
mm				Nm	N/mm <sup>2</sup>	N/mm <sup>2</sup>	–	–	Nm	kg	–
<b>10</b>	20	13	15,5	15	110	55	4	M2.5	1,2	0,019	<b>PHF FX350-10X20</b>
<b>12</b>	22	13	15,5	20	90	50	4	M2.5	1,2	0,022	<b>PHF FX350-12X22</b>
<b>14</b>	26	17	20	35	105	55	4	M3	2,1	0,039	<b>PHF FX350-14X26</b>
<b>15</b>	28	17	20	40	100	50	4	M3	2,1	0,044	<b>PHF FX350-15X28</b>
<b>16</b>	32	17	21	70	130	65	4	M4	4,9	0,067	<b>PHF FX350-16X32</b>
<b>18</b>	35	21	25	80	115	60	4	M4	4,9	0,087	<b>PHF FX350-18X35</b>
<b>19</b>	35	21	25	85	110	60	4	M4	4,9	0,083	<b>PHF FX350-19X35</b>
<b>20</b>	38	21	26	220	220	115	6	M5	10	0,1	<b>PHF FX350-20X38</b>
<b>22</b>	40	21	26	240	200	110	6	M5	10	0,11	<b>PHF FX350-22X40</b>
<b>24</b>	47	26	32	380	220	110	6	M6	17	0,19	<b>PHF FX350-24X47</b>
<b>25</b>	47	26	32	390	210	110	6	M6	17	0,19	<b>PHF FX350-25X47</b>

**FX400**

d 45 – 400 mm

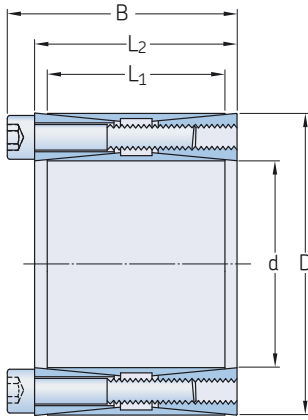

Dimensions					Performance	Transmissible	Pressure		Clamp screws		Weight	Designation	
d	D	L <sub>1</sub>	L <sub>2</sub>	B	Transmissible axial force F <sub>t</sub>	torque M <sub>t</sub>	Shaft surface P <sub>w</sub>	Hub surface P <sub>n</sub>	Qty	Size	Tightening torque M <sub>s</sub>	kg	
mm					kN	Nm	N/mm <sup>2</sup>	N/mm <sup>2</sup>	–	–	Nm		–
45	75	56	64	72	155	3 460	165	100	8	M8	41	1,3	PHF FX400-45X75
48	80	56	64	72	155	3 680	150	95	8	M8	41	1,5	PHF FX400-48X80
50	80	56	64	72	155	3 820	147	95	8	M8	41	1,4	PHF FX400-50X80
55	85	56	64	72	155	4 260	135	85	8	M8	41	1,5	PHF FX400-55X85
60	90	56	64	72	190	5 820	155	100	10	M8	41	1,5	PHF FX400-60X90
65	95	56	64	72	190	6 270	140	95	10	M8	41	1,6	PHF FX400-65X95
70	110	70	78	88	305	10 730	170	105	10	M10	83	3	PHF FX400-70X110
75	115	70	78	88	305	11 540	155	100	10	M10	83	3,1	PHF FX400-75X115
80	120	70	78	88	369	14 700	175	115	12	M10	83	3,5	PHF FX400-80X120
85	125	70	78	88	369	15 700	165	110	12	M10	83	3,5	PHF FX400-85X125
90	130	70	78	88	370	16 610	157	106	12	M10	83	3,8	PHF FX400-90X130
95	135	70	78	88	370	17 530	150	102	12	M10	83	4	PHF FX400-95X135
100	145	90	100	112	538	26 900	160	110	12	M12	145	6	PHF FX400-100X145
110	155	90	100	112	538	29 530	143	102	12	M12	145	6,2	PHF FX400-110X155
120	165	90	100	112	628	37 610	154	112	14	M12	145	6,8	PHF FX400-120X165
130	180	104	116	130	738	48 000	143	106	12	M14	230	9,8	PHF FX400-130X180
140	190	104	116	130	861	60 290	160	117	14	M14	230	10,2	PHF FX400-140X190
150	200	104	116	130	985	73 800	165	125	16	M14	230	10,9	PHF FX400-150X200
160	210	104	116	130	983	78 770	155	118	16	M14	230	11,5	PHF FX400-160X210
170	225	134	146	162	1 197	101 730	140	108	14	M16	355	17,2	PHF FX400-170X225
180	235	134	146	162	1 369	123 200	150	115	16	M16	355	18	PHF FX400-180X235
190	250	134	146	162	1 368	129 880	141	110	16	M16	355	21,5	PHF FX400-190X250
200	260	134	146	162	1 368	136 840	137	104	16	M16	355	22	PHF FX400-200X260
220	285	134	146	162	1 710	188 000	155	120	20	M16	355	25	PHF FX400-220X285
240	305	134	146	162	1 880	225 000	155	120	22	M16	355	27	PHF FX400-240X305
260	325	134	146	162	1 880	244 000	155	115	22	M16	355	30	PHF FX400-260X325
280	355	165	177	197	2 670	373 000	145	120	20	M20	690	46	PHF FX400-280X355
300	375	165	177	197	2 930	440 000	155	125	22	M20	690	50	PHF FX400-300X375
320	405	165	177	197	2 930	470 000	145	115	22	M20	690	60	PHF FX400-320X405
340	425	165	177	197	3 200	544 000	150	120	24	M20	690	65	PHF FX400-340X425
360	455	190	202	224	3 650	658 000	140	110	22	M22	930	89	PHF FX400-360X455
380	475	190	202	224	4 320	821 000	160	130	26	M22	930	93	PHF FX400-380X475
400	495	190	202	224	4 320	864 000	150	120	26	M22	930	98	PHF FX400-400X495



# SKF – the knowledge engineering company

From the company that invented the self-aligning ball bearing more than 100 years ago, SKF has evolved into a knowledge engineering company that is able to draw on five technology platforms to create unique solutions for its customers. These platforms include bearings, bearing units and seals, of course, but extend to other areas including: lubricants and lubrication systems, critical for long bearing life in many applications; mechatronics that combine mechanical and electronics knowledge into systems for more effective linear motion and sensorized solutions; and a full range of services, from design and logistics support to condition monitoring and reliability systems.

Though the scope has broadened, SKF continues to maintain the world's leadership in the design, manufacture and marketing of rolling bearings, as well as complementary products such as radial seals. SKF also holds an increasingly important position in the market for linear motion products, high-precision aerospace bearings, machine tool spindles and plant maintenance services.

The SKF Group is globally certified to ISO 14001, the international standard for environmental management, as well as OHSAS 18001, the health and safety management standard. Individual divisions have been approved for quality certification in accordance with ISO 9001 and other customer specific requirements.

With over 100 manufacturing sites worldwide and sales companies in 70 countries, SKF is a truly international corporation. In addition, our distributors and dealers in some 15 000 locations around the world, an e-business marketplace and a global distribution system put SKF close to customers for the supply of both products and services. In essence, SKF solutions are available wherever and whenever customers need them. Overall, the SKF brand and the corporation are stronger than ever. As the knowledge engineering company, we stand ready to serve you with world-class product competencies, intellectual resources, and the vision to help you succeed.



© Airbus – photo: e\*im company, H. Goussé

### ***Evolving by-wire technology***

*SKF has a unique expertise in the fast-growing by-wire technology, from fly-by-wire, to drive-by-wire, to work-by-wire. SKF pioneered practical fly-by-wire technology and is a close working partner with all aerospace industry leaders. As an example, virtually all aircraft of the Airbus design use SKF by-wire systems for cockpit flight control.*

*SKF is also a leader in automotive by-wire technology, and has partnered with automotive engineers to develop two concept cars, which employ SKF mechatronics for steering and braking. Further by-wire development has led SKF to produce an all-electric forklift truck, which uses mechatronics rather than hydraulics for all controls.*

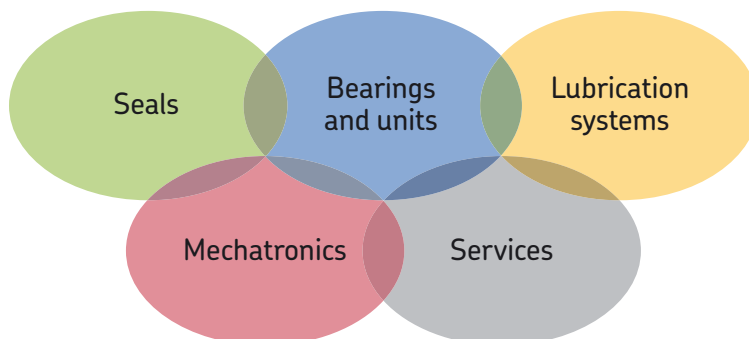



**Harnessing wind power**

The growing industry of wind-generated electric power provides a source of clean, green electricity. SKF is working closely with global industry leaders to develop efficient and trouble-free turbines, providing a wide range of large, highly specialized bearings and condition monitoring systems to extend equipment life of wind farms located in even the most remote and inhospitable environments.



**Working in extreme environments**

In frigid winters, especially in northern countries, extreme sub-zero temperatures can cause bearings in railway axleboxes to seize due to lubrication starvation. SKF created a new family of synthetic lubricants formulated to retain their lubrication viscosity even at these extreme temperatures. SKF knowledge enables manufacturers and end user customers to overcome the performance issues resulting from extreme temperatures, whether hot or cold. For example, SKF products are at work in diverse environments such as baking ovens and instant freezing in food processing plants.



**Developing a cleaner cleaner**

The electric motor and its bearings are the heart of many household appliances. SKF works closely with appliance manufacturers to improve their products' performance, cut costs, reduce weight, and reduce energy consumption. A recent example of this cooperation is a new generation of vacuum cleaners with substantially more suction. SKF knowledge in the area of small bearing technology is also applied to manufacturers of power tools and office equipment.



**Maintaining a 350 km/h R&D lab**

In addition to SKF's renowned research and development facilities in Europe and the United States, Formula One car racing provides a unique environment for SKF to push the limits of bearing technology. For over 60 years, SKF products, engineering and knowledge have helped make Scuderia Ferrari a formidable force in F1 racing. (The average racing Ferrari utilizes around 150 SKF components.) Lessons learned here are applied to the products we provide to automakers and the aftermarket worldwide.



**Delivering Asset Efficiency Optimization**

Through SKF Reliability Systems, SKF provides a comprehensive range of asset efficiency products and services, from condition monitoring hardware and software to maintenance strategies, engineering assistance and machine reliability programmes. To optimize efficiency and boost productivity, some industrial facilities opt for an Integrated Maintenance Solution, in which SKF delivers all services under one fixed-fee, performance-based contract.



**Planning for sustainable growth**

By their very nature, bearings make a positive contribution to the natural environment, enabling machinery to operate more efficiently, consume less power, and require less lubrication. By raising the performance bar for our own products, SKF is enabling a new generation of high-efficiency products and equipment. With an eye to the future and the world we will leave to our children, the SKF Group policy on environment, health and safety, as well as the manufacturing techniques, are planned and implemented to help protect and preserve the earth's limited natural resources. We remain committed to sustainable, environmentally responsible growth.



© SKF is a registered trademark of the SKF Group.

© SKF Group 2010

The contents of this publication are the copyright of the publisher and may not be reproduced (even extracts) unless prior written permission is granted. Every care has been taken to ensure the accuracy of the information contained in this publication but no liability can be accepted for any loss or damage whether direct, indirect or consequential arising out of the use of the information contained herein.

**PUB P7/P1 10114 EN** · May 2010

Printed in Germany on environmentally friendly paper.