

Home at last

The new FNL flanged bearing housing



Approved by the family



Previously it was blue-green. Yet was seen as the black sheep of the family. Now it's the other way around. FNL offers everything you should expect from a modern bearing housing from SKF.

In an instant you can see that it is about a groundbreaking upgrade. The soft lines and the black colour signal a familial relationship with all other bearing housings from SKF. Yet this is about much more than a common facelift. Our designers have developed patented technical solutions that make FNL a reliable and easy-to-handle machine part. Today, it's the hallmark for all SKF bearing housings.

When it comes to our manufacturing process for FNL, we keep full control over all quality parameters, from raw materials to final finish. You also get SKF's built-in knowledge about the bearing housing's role in the function of the bearing. With simple installation and problem-free operation. And secure availability of products in every corner of the world.



FNL is the third branch in the SKF bearing housing family. Together with SNL and SONL, the product group is now complete for all types of applications, type of bearing and lubrication system.

The hallmarks of nobility

Designing a modern bearing housing requires knowledge about the real on-site situation at customer facilities. A clean, uncluttered form for easy handling and cleaning is the obvious foundation – together with clear marks for correct installation and different lubrication alternatives. And most of all technical solutions that promote an efficient bearing arrangement.

A true leader

SKF FNL housings are much more than a seat for a bearing. They are also the key to effective lubrication – even for bearings without a relubrication groove and holes in the outer ring. The housing has an integrated flange that draws in grease from the lubrication nipple to the rolling elements from the side of the bearing.

Signed with skill

Proper installation and adequate lubrication are prerequisites for reliable bearing operation. That's why FNL is equipped with features that remove any doubt. With clear drilling instructions and position marks for alignment.

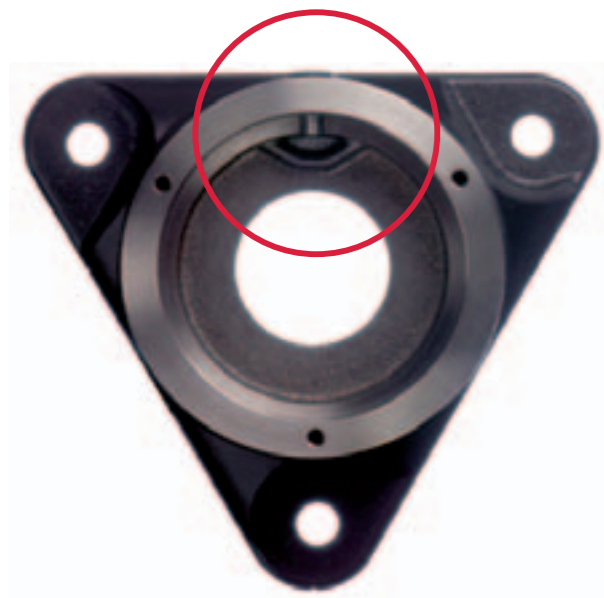

An integrated flange guides grease from the nipple into the bearing.



Alignment is made easier by clear marks on the bearing seating centre and drilling position dimples for dowel pins.



Pre-drilled holes enable relubrication from the side of the bearing or through the W33 groove.

Superior in reality



A modern double-lip low friction seal hydrogenated nitrile butadiene rubber (HNBR) keeps lubrication in position and shuts out contaminants. The new solution allows rotation speed limits twice that possible with traditional felt seals.



SKF – the knowledge engineering company – making knowledge in all its forms available to its customers.

The flanged bearing housing is a well-proven machine part and a simple solution for applications that do not have a horizontal frame. Yet simplicity is no reason to choose the cheapest solution. Material quality, precision-tooled surfaces and careful mounting are just as important here as in any bearing arrangement. FNL gives you modern thinking and long-term functionality.

Accurate mounting

Correct installation is a prerequisite for reliable operation. FNL makes installation quick and easy, while reducing the risk for mistakes. Clear marks show both the housing bore and vertical axis. There are also drilling position dimples for dowel pins.

The recess around the bolt holes leave plenty of room for tools.

Double speed

The old felt strip is no match for a modern double-lip rubber seal that is easier to install and far more reliable. The new design keeps the grease securely in position and effectively shuts out all contaminants. What's more, the new solution allows rotation speed limits twice that allowed by a traditional felt seal. Up to 8 m/s.

Knowledge backup

SKF is a world-leading name when it comes to roller bearings. Under the banner: "The knowledge engineering company", we help industries all over the world reduce friction, minimise environmental impact and improve overall operational economy. This knowledge is made available to you when you chose FNL flanged bearing housings.

Technical information

FNL flanged housings are non-split plummer block housings (**fig. 1**).

The housings are produced in two designs depending on size. Smaller sizes up to and including size 13 have a triangular flange; larger sizes have a square flange.

The housings are equipped with double-lip seals.

Relubrication facility

FNL housings are equipped with two drilled and tapped holes for relubrication as standard, the hole in the middle of the cap should be used when relubricating spherical roller bearings that have a lubrication groove and three holes in the outer ring (W33). Note that spherical roller bearings should be rotating when relubricating via the outer ring. If self-aligning ball bearings or CARB toroidal roller bearings are used, relubrication through the outer ring is not possible. Therefore the hole closest to the flange should be used, to relubricate from the side of the bearing (**figs 2 and 3**).

Grease guiding system

A grease guiding system (**fig. 3**) has been added to FNL housing. This feature guides the grease into the bearing when lubricating self-aligning ball bearings or CARB toroidal roller bearings.

Mounting aid

To simplify mounting, and make alignment more accurate, centre lines to indicate the housing bore axis and vertical axis are cast into the housing flange (**fig. 4**).

Appropriate bearings

FNL housings are designed to accommodate

- self-aligning ball bearings in the 12 K and 22 K series for a shaft diameter ranging from 20 to 100 mm
- spherical roller bearings in the 222 K series for a shaft diameter ranging from 20 to 100 mm
- CARB toroidal roller bearings in the C 22 K series for a shaft diameter ranging from 20 to 100 mm.

Types of arrangement

FNL housings are available for

- bearings on an adapter sleeve for shaft diameters ranging from 20 to 100 mm.

For shaft ends, the housings are supplied with an end cover, designation suffix A (**fig. 5**). The housings for through shafts carry the designation suffix B (**fig. 6**).

Non-locating and locating bearing positions

The bearing seating in the housing is designed for bearings in the non-locating position (**fig. 7**). For bearings in the locating position, or when a CARB toroidal roller bearing is used in the non-locating position, one or two locating rings should be used between the bearing outer ring and the housing shoulder (**fig. 8**).

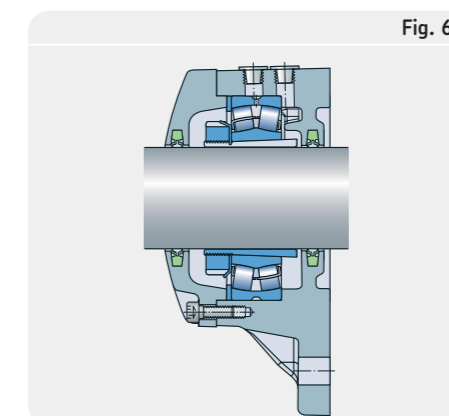
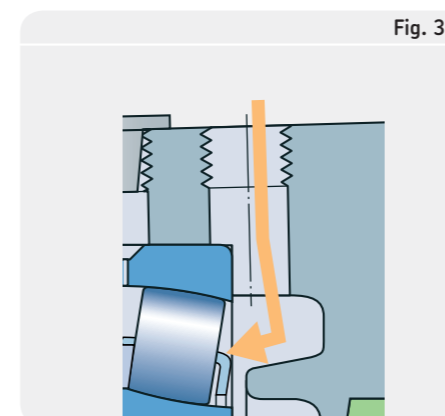
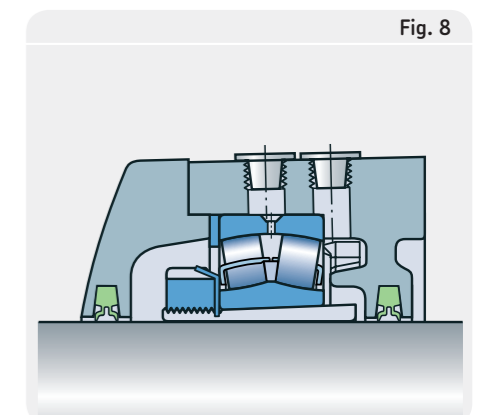
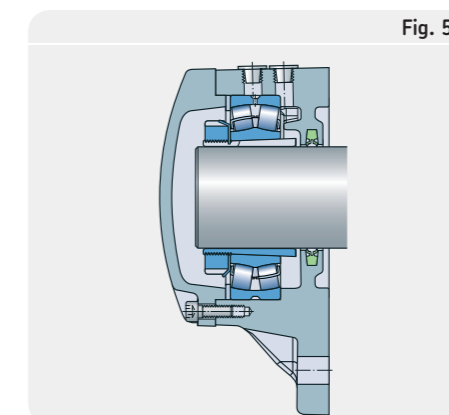
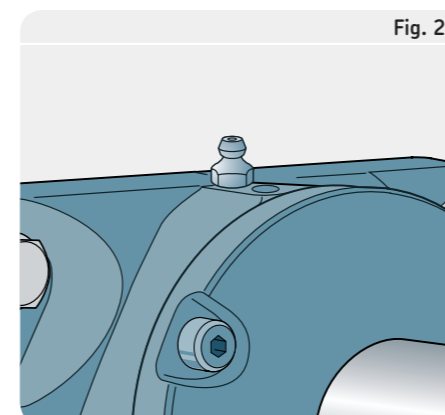
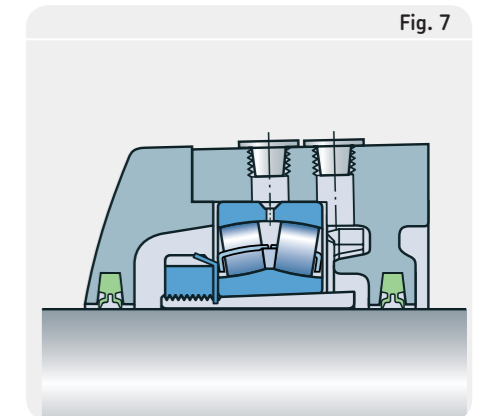
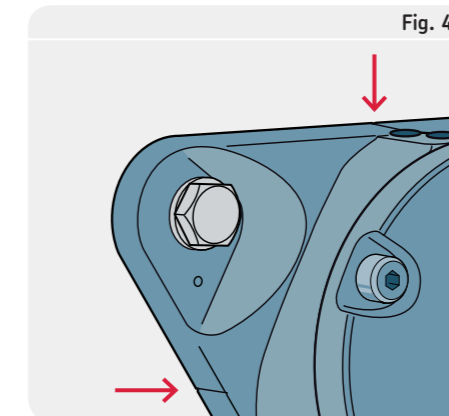
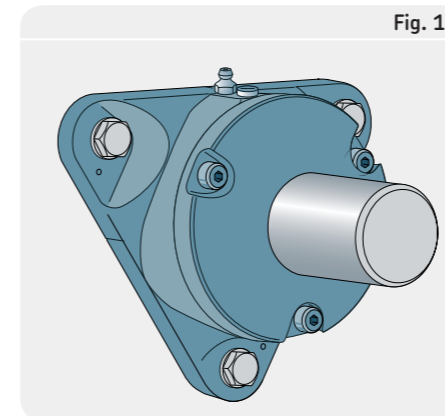

Seals

Double-lip seals

FNL housings are equipped with double-lip grease seals developed by SKF (fig 9). These one-piece hydrogenated nitrile butadiene rubber (HNBR) seals, which are easy to mount, offer increased peripheral speed (up to 8 m/s). These seals, which can accommodate misalignment up to 0.5°, have an operating temperature range from -25 to +120 °C. The counterfaces for the seals on the shaft should be ground and the surface roughness R_a should not exceed 3,2 µm. The recommended shaft tolerance is h9.

Appropriate seals are supplied with the housing. If additional seals are needed, they can be ordered separately. They are identified by the prefix TFL followed by a number indicating the size, e.g. TFL 511.

End cover

For housings located at the end of a shaft end covers are used to cover the housing opening and enhance worker safety. Housings with the designation FNL .. A are supplied with an end cover made of cast iron.



Fig. 9

Lubrication

Grease lubrication

FNL housings are designed for grease lubrication. The housing is equipped with two drilled and tapped holes as standard (figs. 10 and 11). The recommended initial grease fill for the housings is listed in table 1.

Grease guiding system

FNL housings contain a grease guiding system (fig. 11), developed by SKF, for bearings that do not contain a W33 relubrication groove. With this system, grease is guided directly into the bearing to provide better, more efficient relubrication.

Relubrication intervals

In the majority of cases, the amount of grease applied to an FNL housing, at first fill or after an inspection is adequate until the next routine inspection.

Certain operating conditions may require more frequent relubrication is necessary. To enable efficient bearing relubrication, the housings have two tapped holes in the cap. The hole in the middle of the cap is designed to relubricate spherical roller bearings with a W33 lubrication feature in the outer ring (fig. 10). Note: when relubricating a bearing with the W33 feature, the bearing should be rotating. For self-aligning ball bearings or CARB toroidal roller bearings that do not contain the W33 feature or when relubrication via the outer ring is not possible, the second hole closest to the flange, should be used (fig. 11).

A grease nipple AH 1/8-27 PTF and a plastic plug are supplied together with the housing. The plastic plug should be used to protect the relubrication hole that does not contain a grease nipple. The thread size for housings is 1/8-27 NPSF.

To avoid the rework necessary to accommodate a grease nipple with different threads, an adapter, designation LAPN 1/8 is available.

SKF recommends removing the housing cover periodically to remove used grease. The time interval for this depends on the application, the size of the bearing and the amount of grease applied during relubrication.

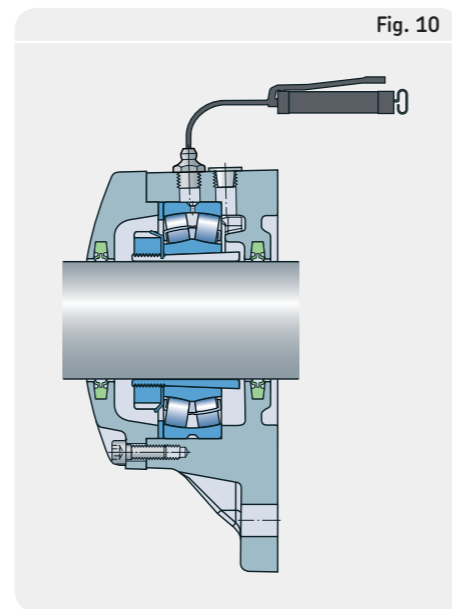

Fig. 10

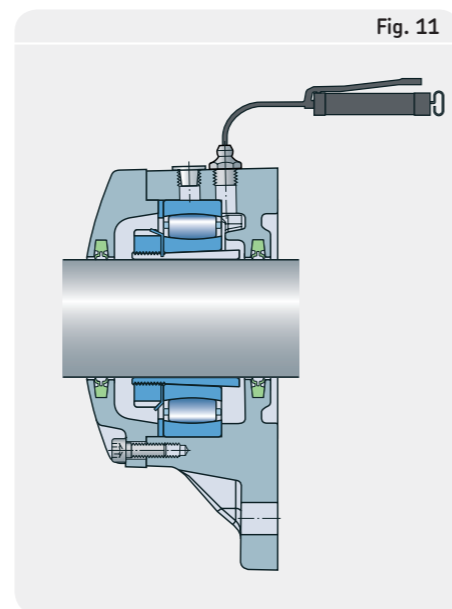

Fig. 11

Mounting

The housing support surface

To provide maximum reliability and long bearing service life, it is recommended that the support surfaces have

- a surface roughness $R_a \leq 12,5 \mu\text{m}$
- a flatness (planicity) measured diagonally to IT7.

Dowel pins

FNL housings are designed to take radial bearing loads mainly. If the bearings are subjected to moderate or heavy radial loads, the housing should be pinned to its support or a stop should be provided. The appropriate positions for these dowel pins are indicated by dimples in the housing.

Attachment bolts

Recommendations for appropriate attachment bolts and tightening torques can be found in table 1.

To attach FNL housings to their support surface, SKF recommend using class 8.8 hexagonal head bolts according to EN ISO 24012:1992.

If the bearing arrangement is subjected to heavy radial loads, SKF recommends using stronger, 10.9 class bolts.

Guiding and supporting the housing

As a variant the FNL housing can be supplied with a machined recess that can be used to centre the housing on an appropriate spigot on the machine wall (table 2 diameters D_i and D_y). As such, the attachment bolts are not subjected to shear forces. This spigot can be provided by

- machining the wall accordingly
- attach an appropriate guide ring to the wall

Appropriate dimensions for guide rings are provided in table 2.

This variant of housing should be ordered with designation suffix P, e.g. FNL 511 BP.

Table 1

| Housing Size | Cover bolts 8.8 Tightening torque | | Attachment bolts 8.8 Tightening torque | | Grease quantity Initial fill |
|--------------|-----------------------------------|----|--|-----|------------------------------|
| – | | Nm | | Nm | kg |
| FNL 505 | M 5 | 6 | M 10 | 50 | 0,015 |
| FNL 506 | M 5 | 6 | M 10 | 50 | 0,025 |
| FNL 507 | M 5 | 6 | M 12 | 80 | 0,035 |
| FNL 508 | M 5 | 6 | M 12 | 80 | 0,045 |
| FNL 509 | M 6 | 10 | M 12 | 80 | 0,050 |
| FNL 510 | M 6 | 10 | M 12 | 80 | 0,050 |
| FNL 511 | M 6 | 10 | M 12 | 80 | 0,060 |
| FNL 512 | M 6 | 10 | M 12 | 80 | 0,090 |
| FNL 513 | M 6 | 10 | M 12 | 80 | 0,12 |
| FNL 515 | M 8 | 24 | M 16 | 200 | 0,25 |
| FNL 516 | M 8 | 24 | M 16 | 200 | 0,30 |
| FNL 517 | M 8 | 24 | M 16 | 200 | 0,35 |
| FNL 518 | M 8 | 24 | M 16 | 200 | 0,40 |
| FNL 520 | M 10 | 47 | M 20 | 385 | 0,50 |
| FNL 522 | M 10 | 47 | M 20 | 385 | 0,65 |

Table 2

Machined recess for guiding of FNL housings

| Housing Size | Machined recess for guiding | | |
|--------------|-----------------------------|----------|-----------|
| | b | D_y H8 | D_i min |
| – | mm | | |
| FNL 505 | – | – | – |
| FNL 506 | 3 | 70 | 48 |
| FNL 507 | – | – | – |
| FNL 508 | 4 | 90 | 60 |
| FNL 509 | 4 | 100 | 65 |
| FNL 510 | 5 | 100 | 68 |
| FNL 511 | 5 | 105 | 78 |
| FNL 512 | 5 | 120 | 90 |
| FNL 513 | 5 | 130 | 90 |
| FNL 515 | – | – | – |
| FNL 516 | – | – | – |
| FNL 517 | – | – | – |
| FNL 518 | 7 | 170 | 120 |
| FNL 520 | – | – | – |
| FNL 522 | – | – | – |

For missing dimensions please consult SKF

Mounting instructions for two FNL housings with double-lip seals

The mounting procedure is different depending on the position of the housings. Here follow mounting instructions for two FNL housings being mounted on the inside or outside of the walls.

1. Check that the roughness of the support surface $R_a \leq 12,5 \mu\text{m}$ and the flatness (planicity) tolerance conforms to IT7. Check that the mounting surface is clean. If shims are used the entire contact surface must be covered. The mounting surface (frame) must be designed in a proper way considering actual load, vibrations and settings.

2. Be sure that all work surfaces are clean. Check the dimensional and form accuracy of the shaft seating. The shaft should be machined to tolerance $h9/IT5$.

3. Mount any components that are on the shaft between the two FNL housings.

4. Insert a seal in the sealing groove in the housings. For a through shaft insert a seal in the sealing groove in the covers. Fill the space between the seal lips with the same grease as used for lubrication.

5. Position the housings on the support surface. Markings on the housing flange, showing the center of the bearing seating, facilitate this. Fit the attachment bolts and lightly tighten the bolts.

6. Put the shaft in approximate position, being allowed to rest in the bore of the housings.

7. Completely fill the bearing with grease. The remainder of the recommended grease fill should be put in the housing, on either side of the bearing. (see **table 1**)

8. The bearing in the locating position should be mounted first. Determine the position of the adapter sleeve of the locating bearing on the shaft. Take into consideration that during mounting

- the bearing will move axially on the sleeve or vice versa
- the shaft will move axially against the bearing

9. Wipe the preservative from the bore and outside surface of the adapter sleeve and oil them lightly with a thin oil. Expand the adapter sleeve slightly by inserting a screwdriver in the slot of the sleeve and push the adapter sleeve into position on the shaft.

A. For FNL housings mounted on the inside of the walls:

10a. Slide the bearing up onto the adapter sleeve. Install the locking washer and screw the lock nut onto the adapter sleeve. Tighten the lock nut until the correct bearing clearance reduction or axial drive up is obtained. Be careful not to damage the tabs on the locking washer whilst tightening the nut. Lock the nut in position by bending down a tab on the locking washer into one of the slots provided around the circumference of the nut. Make sure the mounting force is only applied to the inner ring of the bearing that is being mounted, e.g. by supporting the shaft.

B. For FNL housings mounted on the outside of the walls:

10b. Slide the bearing up onto the adapter sleeve. Install the lock nut without the locking washer and screw the lock nut onto the adapter sleeve. Tighten the lock nut until the correct bearing clearance reduction or axial drive up is obtained. Then unscrew the lock nut and mount the locking washer before mounting the lock nut again. Lock the nut in position by bending down a tab on the locking washer into one of the slots provided around the circumference of the nut. Make sure the mounting force is only applied to the inner ring of the bearing that is being mounted, e.g. by supporting the shaft.

11. Slide the bearing into its bearing housing seating. Install the locating ring(s). Place the cover over the housing and tighten the cover bolts, with a torque wrench, to the torque specified in **table 1**.

12. Mount the bearing in the non-locating position. Determine the position of the adapter sleeve of the locating bearing on the shaft. Take into consideration that during mounting

- the bearing will move axially on the sleeve or vice versa
- the shaft will move axially against the bearing

13. Wipe the preservative from the bore and outside surface of the sleeve and oil them lightly with a thin oil. Expand the adapter sleeve slightly by inserting a screwdriver in the slot of the sleeve and push the adapter sleeve onto the shaft.

A. For FNL housings mounted on the inside of the walls:

14a. Slide the bearing up onto the adapter sleeve. Install the locking washer and screw the lock nut onto the adapter sleeve. Slide the bearing and sleeve over the shaft into position in the housing. Make sure that the bearing is mounted at the right position in the housing, having clearance in the direction the bearing is likely to move during operation. Be careful not to damage the tabs on the locking washer whilst tightening the lock nut. Tighten the lock nut until the correct bearing clearance reduction or axial drive up is obtained.

B. For FNL housings mounted on the outside of the walls:

14b. Slide the bearing up onto the adapter sleeve. Install the lock nut without the locking washer and screw the lock nut onto the adapter sleeve. Slide the bearing and sleeve over the shaft into position in the housing. Make sure that the bearing is mounted at the right position in the housing, having clearance in the direction the bearing is likely to move during operation. Tighten the lock nut until the correct bearing clearance reduction or axial drive up is obtained. Then unscrew the lock nut and mount the locking washer before mounting the lock nut again.

15. Make sure the shaft turns smoothly and the bearings are not jammed in place. If necessary, remove the last bearing to be mounted, determine a new installation position for the adapter sleeve at the shaft and mount the bearing again.

16. If the shaft turns smoothly, secure the bearing on the adapter sleeve by bending down a tab on the locking washer into one of the slots provided around the circumference of the nut.

17. If a CARB toroidal roller bearing is used in the non-locating position, install the correct locating ring.

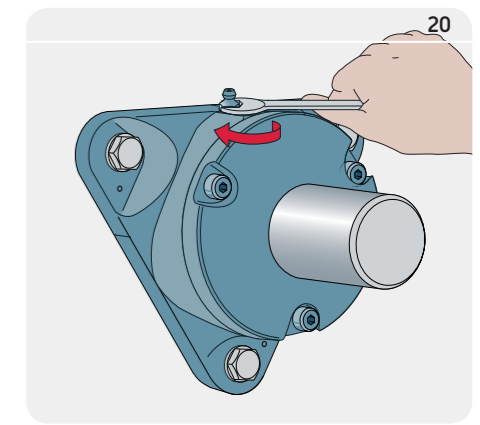
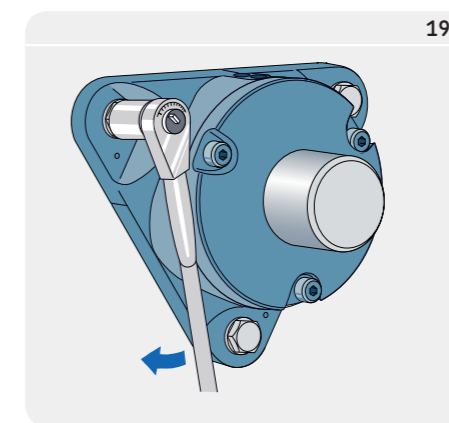
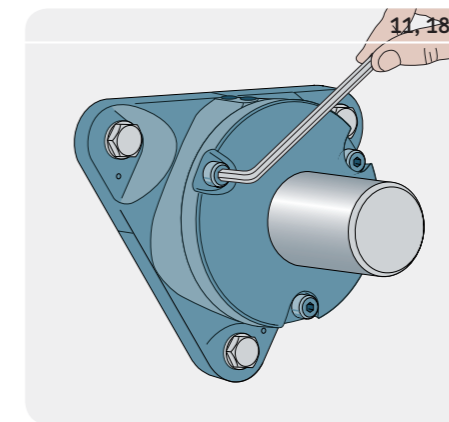
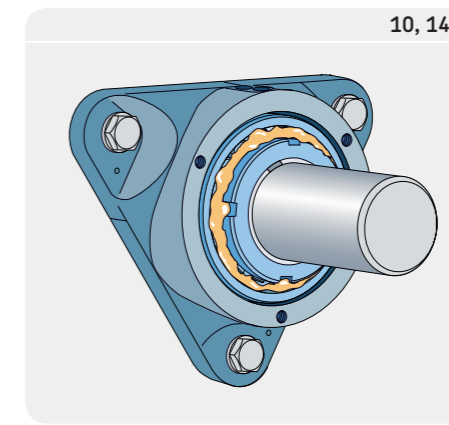
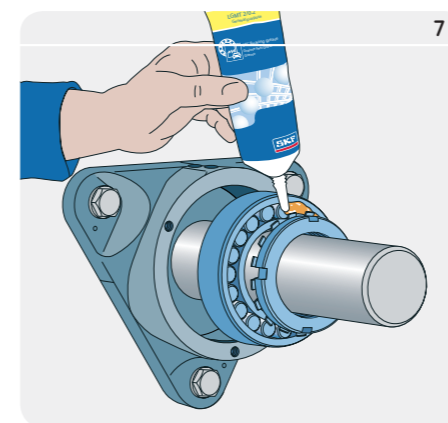
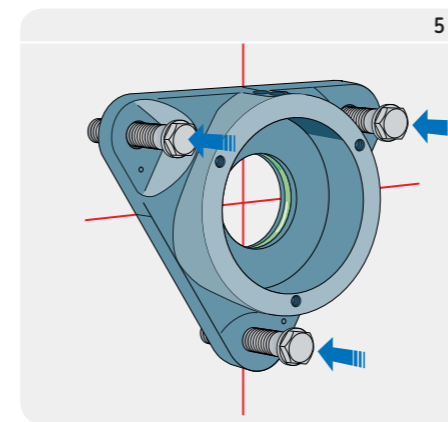
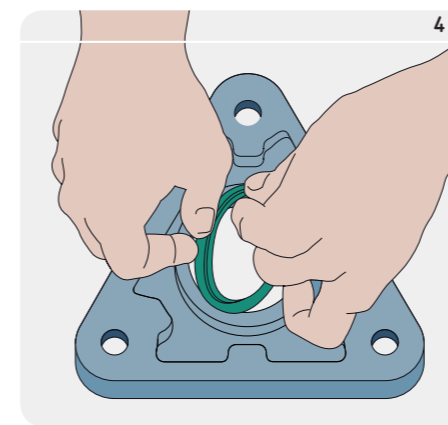

18. Place the cover over the housing and tighten the cover bolts, with a torque wrench, to the torque specified in **table 1**.

19. Carefully align the housings. Fully tighten the attachment bolts in the housing flange with a torque wrench. Recommended tightening torques are provided in **table 1**.

20. Install the grease nipple and plug. If a self-aligning ball bearing or a CARB toroidal

roller bearing is used or if relubrication via the outer ring is not possible the grease nipple must be mounted in the hole closest to the housing flange. If a spherical roller bearing with a W33 feature is used the recommendation is to mount the grease nipple in the hole nearest to the cover.

Housing data – general

Designations

The complete designation of a FNL housing consists of **(Diagram 1)**

- the housing basic design
- the series and size identification
- any supplementary designations that identify variants or deviations from the standard

Dimensions

The dimensions of FNL housings have not been standardized either nationally or internationally, but are generally accepted in the marketplace. FNL housings are dimensionally interchangeable with old 7225(00) housings.

Load carrying ability

The permissible radial loads for flanged housings depend on the installed bearings or the attachment bolts used. If heavy loads are expected, additional supports are recommended to relieve the attachment bolts of the load. Where axial loads are concerned the direction of the loads is the determining factor. If the resultant axial load acts towards the flange, the axial load carrying capacity of the bearing is the deciding factor, whereas if the resultant axial load acts in the opposite direction the permissible load on the cover bolts is the limiting factor. FNL housings are supplied with grade 8.8 bolts as standard.

Radial load carrying ability of the housing

Guideline values for the breaking load P of the housing for various load directions are provided in **table 3**.

The permissible housing load can be obtained from these values by applying a selected safety factor that depends on the operating conditions. In general engineering a safety factor of 6 is often used.

The recommended tightening torques for the attachment bolts are provided in **table 1**.

Materials

FNL housings are made of grey cast iron.

Corrosion protection

FNL housings are painted as standard in accordance with ISO 12944-2:1998, environment class C2.
Black colour: RAL 9005.

Diagram 1

Designation scheme

| Designation scheme | |
|--------------------|--|
| Housing | FNL |
| Size | 505 to 522 |
| Suffixes | A |
| FNL | Non-split, flanged housings for bearings in the 12 K, 22 K, 222 K and CARB C 22 K series on an adapter sleeve and a smooth shaft |
| A | Housing for the end of a shaft with an end cover |
| B | Housing for a through shaft |
| P | Housing with machined recess for guide ring |

Table 3

Breaking loads for FNL housings

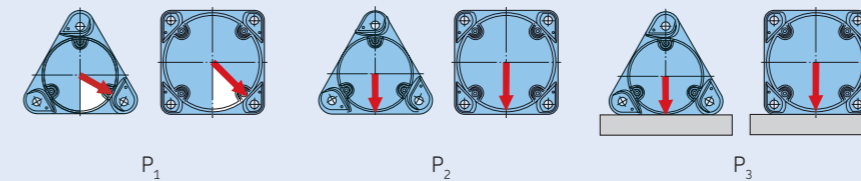

| Housing Size | Breaking loads for FNL housings | | |
|--------------|---------------------------------|----------------|----------------|
| | P ₁ | P ₂ | P ₃ |
| – | kN | | |
| FNL 505 | 50 | 40 | 80 |
| FNL 506 | 60 | 45 | 85 |
| FNL 507 | 70 | 50 | 90 |
| FNL 508 | 80 | 55 | 95 |
| FNL 509 | 90 | 60 | 100 |
| FNL 510 | 100 | 65 | 105 |
| FNL 511 | 110 | 80 | 110 |
| FNL 512 | 120 | 95 | 115 |
| FNL 513 | 130 | 110 | 190 |
| FNL 515 | 140 | 125 | 265 |
| FNL 516 | 150 | 140 | 340 |
| FNL 517 | 160 | 155 | 415 |
| FNL 518 | 170 | 170 | 490 |
| FNL 520 | 180 | 185 | 565 |
| FNL 522 | 190 | 200 | 640 |

FNL flanged housings for bearings with an adapter sleeve
 d_a 20 – 60 mm

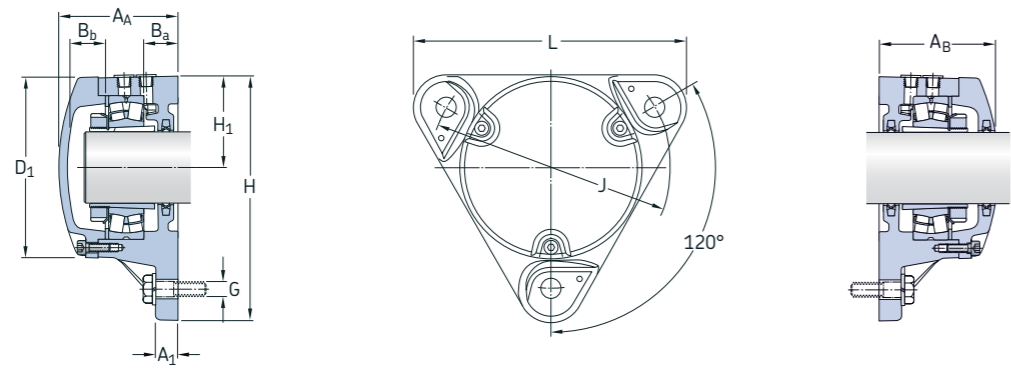

| Shaft diam. | Housing dimensions | | | | | | | | | | | Mass | Designations Housing of grey cast iron for shaft end through shaft | | Appropriate bearing and associated components | | | Separate components | |
|-------------|--------------------|----------------|----------------|----------------|------------------------------|----------------|-------|----------------|-----|-----|----|------|---|------------------|---|------------------------------------|--|---------------------|-----------------|
| | A _A | A _B | A ₁ | B _a | B _b ¹⁾ | D ₁ | H | H ₁ | J | L | G | | | | Self-aligning ball bearings | Adapter sleeve | Locating ring or spacing washer | Contact seal | End cover bolts |
| mm | mm | | | | | | | | | | | kg | – | | – | | | – | |
| 20 | – | – | 10 | 15 | – | – | 100 | 38 | 96 | 110 | 10 | – | FNL 505 A | FNL 505 B | 1205 EKTN9 2205 EKTN9 22205 EK C 2205 KTN9 ²⁾ | H 205 H 305 H 305 H 305 E | 1 FRB 5/52 1 ZW 42 x 52 1 ZW 42 x 52 1 ZW 42 x 52 | TFL 505 | M 5 x 16 |
| 25 | 60,5 | 60 | 12 | 16 | 15 | 86 | 117 | 44 | 116 | 130 | 10 | 1,6 | FNL 506 A | FNL 506 B | 1206 EKTN9 2206 EKTN9 22206 EK C 2206 KTN9 | H 206 H 306 H 306 H 306 E | 1 FRB 6/62 1 FRB 2/62 1 FRB 2/62 1 FRB 2/62 | TFL 506 | M 5 x 16 |
| 30 | – | – | 12 | 16 | – | – | 130 | 48,5 | 130 | 145 | 12 | – | FNL 507 A | FNL 507 B | 1207 EKTN9 2207 EKTN9 22207 EK C 2207 KTN9 | H 207 H 307 H 307 H 307 E | 1 FRB 8/72 1 ZW 65 x 72 1 ZW 65 x 72 1 ZW 65 x 72 | TFL 507 | M 5 x 16 |
| 35 | 67 | 66 | 12 | 17 | 18 | 105 | 143 | 54 | 140 | 160 | 12 | 2,4 | FNL 508 A | FNL 508 B | 1208 EKTN9 2208 EKTN9 22208 EK C 2208 KTN9 | H 208 H 308 H 308 H 308 E | 1 FRB 7/80 1 ZW 70 x 80 1 ZW 70 x 80 1 ZW 70 x 80 | TFL 508 | M 5 x 16 |
| 40 | 72 | 70,5 | 12 | 19 | 19 | 113 | 160 | 60 | 160 | 179 | 12 | 3,2 | FNL 509 A | FNL 509 B | 1209 EKTN9 2209 EKTN9 22209 EK C 2209 KTN9 | H 209 H 309 H 309 H 309 E | 1 FRB 6/85 1 ZW 75 x 85 1 ZW 75 x 85 1 ZW 75 x 85 | TFL 509 | M 6 x 20 |
| 45 | 77 | 75 | 15 | 22 | 21 | 118 | 160 | 60 | 160 | 179 | 12 | 3,5 | FNL 510 A | FNL 510 B | 1210 EKTN9 2210 EKTN9 22210 EK C 2210 KTN9 | H 210 H 310 H 310 H 310 E | 1 FRB 5/90 1 ZW 80 x 90 1 ZW 80 x 90 1 ZW 80 x 90 | TFL 510 | M 6 x 20 |
| 50 | 84 | 82 | 15 | 24 | 23 | 127 | 172,5 | 65 | 170 | 192 | 12 | 4,3 | FNL 511 A | FNL 511 B | 1211 EKTN9 2211 EKTN9 22211 EK C 2211 KTN9 | H 211 H 311 H 311 H 311 E | 1 FRB 6/100 1 ZW 85 x 100 1 ZW 85 x 100 1 ZW 85 x 100 | TFL 511 | M 6 x 20 |
| 55 | 85 | 83 | 15 | 23 | 22 | 142 | 189 | 72 | 180 | 210 | 12 | 5,2 | FNL 512 A | FNL 512 B | 1212 EKTN9 2212 EKTN9 22212 EK C 2212 KTN9 | H 212 H 312 H 312 H 312 E | 1 FRB 8/110 1 FRB 2/110 1 FRB 2/110 1 FRB 2/110 | TFL 512 | M 6 x 20 |
| 60 | 88 | 86 | 15 | 22 | 24 | 152 | 203 | 78 | 190 | 225 | 12 | 6,3 | FNL 513 A | FNL 513 B | 1213 EKTN9 2213 EKTN9 22213 EK C 2213 KTN9 | H 213 H 313 H 313 H 313 E | 1 FRB 10/120 1 FRB 2/120 1 FRB 2/120 1 FRB 2/120 | TFL 513 | M 6 x 20 |

For missing dimensions please consult SKF

¹⁾ Maximum space, from bearing, for shaft end to end cover

²⁾ Please check availability of the bearing before incorporating it in a bearing arrangement design

FNL flanged housings for bearings with an adapter sleeve
 d_a 65 – 100 mm

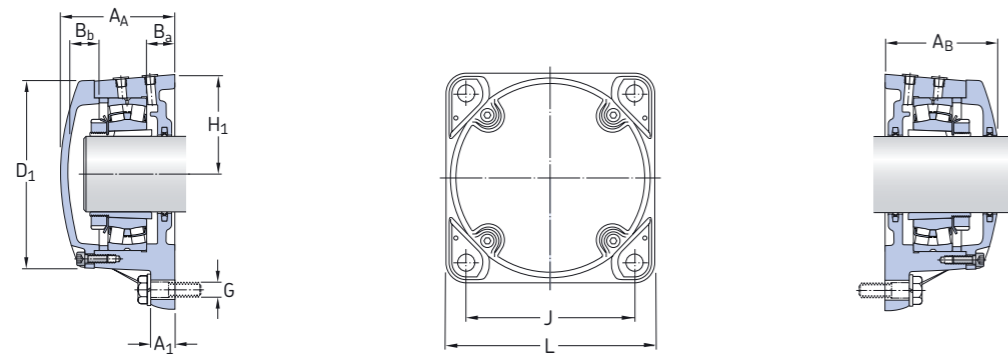

| Shaft diam. | Housing dimensions | | | | | | | | | | | Mass | Designation Housing of grey cast iron for shaft end through shaft | | Appropriate bearing and associated components | | | Separate components | |
|-------------|--------------------|----------------|----------------|----------------|------------------------------|----------------|-----|----------------|-----|-----|----|------|--|------------------|---|--|--|---------------------|-----------------|
| | A _A | A _B | A ₁ | B _a | B _b ¹⁾ | D ₁ | H | H ₁ | J | L | G | | | | Self-aligning ball bearings | Adapter sleeve | Locating ring(s) | Contact seal | End cover bolts |
| mm | mm | | | | | | | | | | | kg | - | | - | | | - | |
| 65 | - | - | 25 | 30 | - | - | 190 | 95 | 152 | 190 | 16 | - | FNL 515 A | FNL 515 B | 1215 K 2215 EKTN9 22215 EK C 2215 K | H 215 H 315 H 315 H 315 E | 2 FRB 8/130 1 FRB 10/130 1 FRB 10/130 1 FRB 10/130 | TFL 515 | M 8 x 25 |
| 70 | - | - | 25 | 31 | - | - | 196 | 98 | 152 | 196 | 16 | - | FNL 516 A | FNL 516 B | 1216 K 2216 EK 22216 EK C 2216 K | H 216 H 316 H 316 H 316 E | 2 FRB 8,5/140 1 FRB 10/140 1 FRB 10/140 1 FRB 10/140 | TFL 516 | M 8 x 25 |
| 75 | - | - | 25 | 31 | - | - | 210 | 105 | 170 | 210 | 16 | - | FNL 517 A | FNL 517 B | 1217 K 2217 K 22217 EK C 2217 K | H 217 H 317 H 317 H 317 E | 2 FRB 9/150 1 FRB 10/150 1 FRB 10/150 1 FRB 10/150 | TFL 517 | M 8 x 25 |
| 80 | 121 | 118 | 25 | 30 | 28 | 196 | 210 | 105 | 170 | 210 | 16 | 12,0 | FNL 518 A | FNL 518 B | 1218 K 2218 K 22218 EK C 2218 K | H 218 H 318 H 318 H 318 E | 2 FRB 10/160 1 FRB 10/160 1 FRB 10/160 1 FRB 10/160 | TFL 518 | M 8 x 25 |
| 90 | - | - | 30 | 30 | - | - | 250 | 125 | 198 | 250 | 20 | - | FNL 520 A | FNL 520 B | 1220 K 2220 KM 22220 EK C 2220 K | H 220 H 320 H 320 H 320 E | 1 FRB 10/180 ²⁾ 1 FRB 12/180 ²⁾ 1 FRB 10/180 1 FRB 10/180 1 FRB 10/180 | TFL 520 | M 10 x 30 |
| 100 | - | - | 30 | 30 | - | - | 270 | 135 | 219 | 270 | 20 | - | FNL 522 A | FNL 522 B | 1222 K 2222 KM 22222 EK C 2222 K | H 222 H 322 H 322 H 322 E | 2 FRB 12,5/200 1 FRB 10/200 1 FRB 10/200 1 FRB 10/200 | TFL 522 | M 10 x 30 |

For missing dimensions please consult SKF

¹⁾ Maximum space, from bearing, for shaft end to end cover

²⁾ Please note that one FRB 10/180 and one FRB 12/180 has to be used at the same time

SKF and CARB are registered trademarks of the SKF Group.

© SKF Group 2006
The contents of this publication are the copyright of the publisher and may not be reproduced (even extracts) unless permission is granted. Every care has been taken to ensure the accuracy of the information contained in this publication but no liability can be accepted for any loss or damage whether direct, indirect or consequential arising out of the use of the information contained herein.

Publication 6397 EN • November 2006

