

SKF Couplings





Contents

The SKF brand now stands for more than ever before, and means more to you as a valued customer.

While SKF maintains its leadership as a high-quality bearing manufacturer throughout the world, new dimensions in technical advances, product support and services have evolved SKF into a truly solutions-oriented supplier, creating greater value for customers.

These solutions enable customers to improve productivity, not only with breakthrough application-specific products, but also through leading-edge design simulation tools and consultancy services, plant asset efficiency maintenance programmes, and the industry's most advanced supply management techniques.

The SKF brand still stands for the very best in rolling bearings, but it now stands for much more.

SKF – the knowledge engineering company

SKF Couplings	3	SKF FRC Couplings	48
Selection	4	Selection	48
Standard selection method	4	Example	48
Standard selection example	5	Engineering data	48
Formula method	5	Power ratings	48
Formula selection example	5	Order data	48
Engineering data	6	Installation	50
Order data	8	SKF Jaw Couplings	52
Full spacer and half spacer coupling types	8	Selection	52
Horizontal and vertical cover types	8	Example	52
Installation	10	Engineering data	52
SKF grid removal	10	Power ratings	52
SKF Gear Couplings	16	Order data	52
Selection	16	Installation	54
Standard selection method	16	SKF Universal Joints	56
Standard selection example	17	Selection	56
Formula method	17	Example	56
Formula selection example	18	Engineering data	56
Engineering data	18	Order data	56
Order data	18	General engineering data on SKF Couplings	58
Installation	20	Lubrication	62
Floating shaft gear couplings	30	General purpose grease	62
Flex hubs on floating shafts	30	Shaft alignment tools	63
Rigid hubs on floating shaft	30	TMEA series	63
Solid floating shaft selection	31	TMEA 2	64
SKF Flex Couplings	34	TMEA 1P/2,5	64
Selection	34	TMEA 1PEX	65
Example	34	Thermal printer TMEA P1	65
Engineering data	34	Machinery shims TMAS series	66
Power ratings	34	Inspection tool	67
Order data	36	Stroboscope TMRS 1	67
Installation	37	SKF – the knowledge engineering company	68
SKF Flex Spacer Coupling	40		
Installation	41		
To dismantle	41		
SKF Chain Couplings	44		
Selection	44		
Example	44		
Engineering data	45		
Power ratings	45		
Order data	45		
Installation	46		

SKF Couplings

Flexible couplings are devices used to mechanically connect two shafts to transmit power from one shaft to the other. They are also able to compensate for shaft misalignment in a torsionally rigid way. Misalignment can be angular, parallel or skew. This is particularly important for applications where misalignment could affect the velocity and acceleration of the driven shaft. The performance of the coupling depends largely upon how it is installed, aligned and maintained.

In response to industry's ultimate need to produce more with less, SKF has combined its knowledge and experience with the latest technology to develop solutions for a variety of applications and operating conditions. Whether the goal is to design equipment that provides more customer value, or to improve overall profitability, SKF's experience and expertise can help you meet your goals.

SKF offers a wide range of standard and customised coupling products. SKF Couplings cover a wide range of coupling types, sizes and capacity ratings for many applications and factory environments.

For large, heavy duty applications, SKF has large size couplings. These couplings, which provide optimum contact with the shaft, can accommodate high torque values, while reducing power loss and minimizing the effects of misalignment.



SKF Grid Couplings

In high output (kW) and high torque applications where vibration, shock loads and misalignment occur, SKF Grid Couplings are an excellent choice.

The unique design of the grid and hub teeth enable these couplings to accommodate movement and stresses from all three planes, which can reduce vibration levels by as much as 30%.

The tapered grid element is manufactured from a high strength alloy steel. The grid, which, is the primary wear component of the coupling is designed for quick and easy replacement. Unlike other couplings, the hubs and other components are not disturbed. This makes realignment unnecessary and further reduces downtime and maintenance costs.

Selection

Standard selection method

This selection procedure can be used for most motor, turbine, or engine driven applications. The following information is required to select an SKF grid coupling:

- Torque – power [kW]
- Speed [r/min]
- Type of equipment and application
- Shaft diameters
- Shaft gaps
- Physical space limitation
- Special bore or finish information

Exceptions to use of the standard selection method are for high peak loads and brake applications. For these, use the formula selection method or contact SKF.

1 Determine system torque

If torque is not given, use the following formula to calculate for torque (T)

$$\text{System torque} = \frac{\text{Power [kW]} \times 9\,549}{\text{Speed [r/min]}}$$

2 Service factor

Determine the service factor from **tables 7 and 8 on pages 60 and 61.**

3 Coupling rating

Determine the required minimum coupling rating as shown below:

$$\text{Coupling rating} = \text{service factor} \times \text{torque [Nm]}$$

4 Size

Select the appropriate coupling from the torque column of the product tables on **pages 12 to 14** with a value that is equal to or greater than that determined in **step 3** above and check that the chosen coupling can accommodate both driving and driven shafts.

5 Other considerations

Possible other restrictions might be speed [r/min], bore, gap and dimensions.

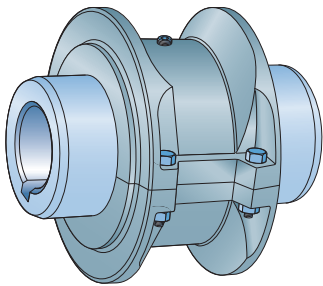

Horizontal split cover → [page 12](#)

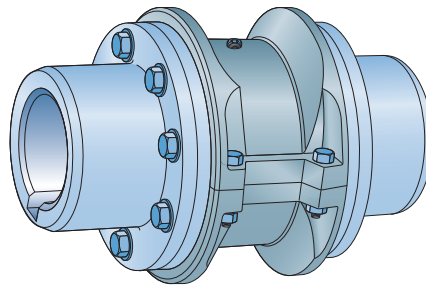

Full spacer → [page 14](#)

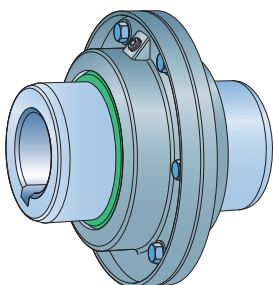

Vertical split cover → [page 13](#)

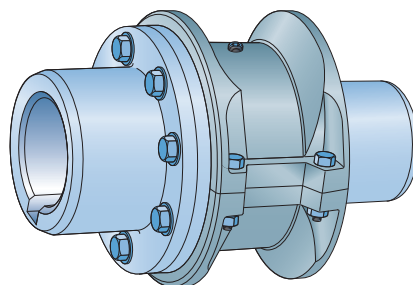

Half spacer → [page 15](#)

Standard selection example

Select a coupling to connect a 30 kW, 1 440 r/min electric motor that is driving a boiler feed pump. The motor shaft diameter is 55 mm, pump shaft diameter is 45 mm. Shaft extensions are 140 mm and 110 mm. The coupling to be selected will replace a gear type coupling with a 3 mm gap.

1 Determine system torque

System torque [Nm] =

$$\frac{30 \text{ kW} \times 9\,549}{1\,440 \text{ r/min}} = 199 \text{ Nm}$$

2 Service factor

From **table 7** on **page 60** = 1,50

3 Required coupling rating

$$1,5 \times 199 \text{ Nm} = 298,5 \text{ Nm}$$

4 Size

From product tables on **page 12**, the coupling size 1060 is the proper selection based on the torque rating of 684 Nm which exceeds the required minimum rating of 298,5 Nm as well as accommodating driving and driven shaft diameter requirements.

5 Other considerations

The speed capacity of 4 500 (coupling size 1060) exceeds the required speed of 1 440 r/min. The maximum bore capacity of 57 mm exceeds the required shaft diameters of 55 mm and 45 mm. The resulting service factor is 2,29. This will provide a very good service life for the coupling and a high level of reliability.

Formula method

The standard selection method can be used for most coupling selections. However, the formula method, should be used for:

- high peak loads
- brake applications (if a brake wheel is to be an integral part of the coupling)

By including the system's peak torque, frequency, duty cycle and brake torque ratings, a more accurate result will be obtained.

1 High peak loads

Use one of the following formulas (A, B, or C) for:

- Motors with higher than normal torque characteristics.
- Applications with intermittent operations resulting in shock loads.
- Inertia effects due to frequent stops and starts or repetitive high peak torques.

Peak torque is the maximum torque that can exist in the system. Select a coupling with a torque rating equal to or exceeding the selection torque values obtained from the formulas below.

A Non-reversing peak torque selection

Torque [Nm] = system peak torque

or

Selection torque [Nm] =

$$\frac{\text{System peak kW} \times 9\,549}{\text{r/min}}$$

B Reversing high peak torque

Selection torque [Nm] =

$$\frac{2 \times \text{system peak torque}}{\text{r/min}}$$

C Occasional peak torques (non-reversing)

If a system peak torque occurs less than 1 000 times during the expected coupling life, use the following formula:

Selection torque [Nm] =

$$0,5 \times \text{system peak torque}$$

or

Selection torque [Nm] =

$$\frac{0,5 \times \text{system peak kW} \times 9\,549}{\text{r/min}}$$

2 Brake applications

If the torque rating of the brake exceeds the motor torque, use the brake rating as follows:

Selection Torque [Nm] =

Brake torque rating × service factor.

Formula selection example

High peak load

Select a coupling for reversing service to connect a gear drive low speed shaft to a metal forming mill drive. The electric motor rating is 30 kW and the system peak torque at the coupling is estimated to be 9 000 Nm. Coupling speed is 66 r/min at the gear drive output with a shaft gap (between ends) of 180 mm.

1 Type

Refer to product tables on **pages 12 to 14** and select the appropriate coupling type.

2 Required minimum coupling rating

Use the reversing high peak torque formula in step 1B.

$$2 \times 9\,000 \text{ Nm} = 18\,000 \text{ Nm} = \text{Selection torque}$$

3 Size

From product table on **page 12**, size 1130 with a torque rating of 19 900 which exceeds the selection torque of 18 000 Nm.

4 Other considerations

Grid coupling size 1130 has a maximum "DBSE" dimension (distance between shaft ends) of 205 mm; the shaft hub has a maximum bore of 190 mm.

Note

See product table on **page 12**. The T hub has a maximum bore of 170 mm and the allowable speed of 1 800 r/min.

Engineering data

For additional useful information on grid couplings, such as an interchange guide, misalignment capability, puller bolt hole, inertia and standard stock spacer lengths data, please refer to **tables 1 to 6**.

Table 1

SKF grid coupling interchange guide

Horizontal split cover

SKF	Falk	Morse/ Browning	Dodge	Kop-Flex	Lovejoy	Bibby
PHE 1020TGHRSB	1020T10	GF2020H	1020T10	1020H	1020	2020H
PHE 1030TGHRSB	1030T10	GF2030H	1030T10	1030H	1030	2030H
PHE 1040TGHRSB	1040T10	GF2040H	1040T10	1040H	1040	2040H
PHE 1050TGHRSB	1050T10	GF2050H	1050T10	1050H	1050	2050H
PHE 1060TGHRSB	1060T10	GF2060H	1060T10	1060H	1060	2060H
PHE 1070TGHRSB	1070T10	GF2070H	1070T10	1070H	1070	2070H
PHE 1080TGHRSB	1080T10	GF2080H	1080T10	1080H	1080	2080H
PHE 1090TGHRSB	1090T10	GF2090H	1090T10	1090H	1090	2090H
PHE 1100TGHRSB	1100T10	GF2100H	1100T10	1100H	1100	2100H
PHE 1110TGHRSB	1110T10	GF2110H	1110T10	1110H	1110	2110H
PHE 1120TGHRSB	1120T10	GF2120H	1120T10	1120H	1120	2120H
PHE 1130TGHRSB	1130T10	GF2130H	1130T10	1130H	1130	2130H
PHE 1140TGHRSB	1140T10	GF2140H	1140T10	1140H	1140	2140H
PHE 1150TGHRSB	1150T10	-	-	-	1150	-
PHE 1160TGHRSB	1160T10	-	-	-	1160	-
PHE 1170TGHRSB	1170T10	-	-	-	1170	-
PHE 1180TGHRSB	1180T10	-	-	-	1180	-
PHE 1190TGHRSB	1190T10	-	-	-	1190	-
PHE 1200TGHRSB	1200T10	-	-	-	1200	-

Table 2

SKF grid coupling interchange guide

Vertical split cover

SKF	Falk	Morse/ Browning	Dodge	Kop-Flex	Lovejoy	Bibby
PHE 1020TGVRSB	1020T20	GF2020V	1020T20	1020V	1020	2020V
PHE 1030TGVRSB	1030T20	GF2030V	1030T20	1030V	1030	2030V
PHE 1040TGVRSB	1040T20	GF2040V	1040T20	1040V	1040	2040V
PHE 1050TGVRSB	1050T20	GF2050V	1050T20	1050V	1050	2050V
PHE 1060TGVRSB	1060T20	GF2060V	1060T20	1060V	1060	2060V
PHE 1070TGVRSB	1070T20	GF2070V	1070T20	1070V	1070	2070V
PHE 1080TGVRSB	1080T20	GF2080V	1080T20	1080V	1080	2080V
PHE 1090TGVRSB	1090T20	GF2090V	1090T20	1090V	1090	2090V
PHE 1100TGVRSB	1100T20	GF2100V	1100T20	1100V	1100	2100V
PHE 1110TGVRSB	1110T20	GF2110V	1110T20	1110V	1110	2110V
PHE 1120TGVRSB	1120T20	GF2120V	1120T20	1120V	1120	2120V
PHE 1130TGVRSB	1130T20	GF2130V	1130T20	1130V	1130	2130V
PHE 1140TGVRSB	1140T20	GF2140V	1140T20	1140V	1140	2140V
PHE 1150TGVRSB	1150T20	-	-	-	1150	-
PHE 1160TGVRSB	1160T20	-	-	-	1160	-
PHE 1170TGVRSB	1170T20	-	-	-	1170	-
PHE 1180TGVRSB	1180T20	-	-	-	1180	-
PHE 1190TGVRSB	1190T20	-	-	-	1190	-
PHE 1200TGVRSB	1200T20	-	-	-	1200	-

Table 3

Puller bolt hole data

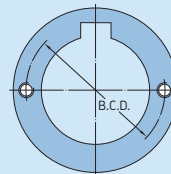

Size	B.C.D.	Bolt	Size	B.C.D.	Bolt
-	mm	-	-	mm	-
PHE 1070TGRSB	74	M8	PHE 1140TGRSB	205	M16
PHE 1080TGRSB	89,5	M8	PHE 1150TGRSB	227,5	M20
PHE 1090TGRSB	106	M10	PHE 1160TGRSB	260	M20
PHE 1100TGRSB	121,5	M10	PHE 1170TGRSB	306	M24
PHE 1110TGRSB	136,5	M10	PHE 1180TGRSB	341	M30
PHE 1120TGRSB	150,5	M12	PHE 1190TGRSB	393	M30
PHE 1130TGRSB	185	M16	PHE 1200TGRSB	414	M30

Table 4

Misalignment capability

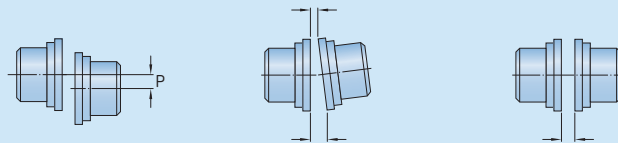

Size	Recommended installation		Operating		Normal gap +/- 10%	Tightening torque Nm
	Parallel offset P	Angular 1/16°	Parallel offset P	Angular 1/4°		
-	mm	-	-	mm	-	Nm
1020	0,15	0,06	0,30	0,24	3	11,30
1030	0,15	0,07	0,30	0,29	3	11,30
1040	0,15	0,08	0,30	0,32	3	11,30
1050	0,20	0,10	0,40	0,39	3	22,60
1060	0,20	0,11	0,40	0,45	3	22,60
1070	0,20	0,12	0,40	0,50	3	22,60
1080	0,20	0,15	0,40	0,61	3	22,60
1090	0,20	0,17	0,40	0,70	3	22,60
1100	0,25	0,20	0,50	0,82	4,50	35,00
1110	0,25	0,22	0,50	0,90	4,50	35,00
1120	0,28	0,25	0,56	1,01	6	73,00
1130	0,28	0,30	0,56	1,19	6	73,00
1140	0,28	0,33	0,56	1,34	6	73,00
1150	0,30	0,39	0,60	1,56	6	73,40
1160	0,30	0,44	0,60	1,77	6	73,40
1170	0,30	0,50	0,60	2,00	6	146,90
1180	0,38	0,56	0,76	2,26	6	146,90
1190	0,38	0,61	0,76	2,44	6	146,90
1200	0,38	0,68	0,76	2,72	6	259,90

Table 5

Full spacer coupling

TGFS Standard stock spacer lengths (DBSE = Distance between shaft ends)

DBSE	Pump std		Coupling size										
	mm	in.	1020	1030	1040	1050	1060	1070	1080	1080	1090	1100	1110
89	3.50	ANSI	X	X	X	-	-	-	-	-	-	-	-
100	3.94	ISO	X	X	X	-	-	-	-	-	-	-	-
108	4.25	MISC	X	X	X	-	-	-	-	-	-	-	-
111	4.38	ANSI	X	X	X	X	-	-	-	-	-	-	-
119	4.69	MISC	X	X	X	X	-	-	-	-	-	-	-
127	5.00	ANSI	X	X	X	X	X	X	-	-	-	-	-
133	5.22	MISC	-	-	X	-	-	-	-	-	-	-	-
137	5.38	MISC	-	X	X	-	-	-	-	-	-	-	-
140	5.51	ISO	X	X	X	X	X	X	-	-	-	-	-
144	5.66	MISC	-	X	X	-	-	-	-	-	-	-	-
148	5.81	MISC	-	X	X	X	-	-	-	-	-	-	-
152	5.97	MISC	-	-	X	X	-	-	-	-	-	-	-
155	6.12	MISC	-	X	X	X	X	X	-	-	-	-	-
176	6.94	MISC	X	X	X	X	X	-	-	-	-	-	-
178	7.00	ANSI	-	-	-	-	-	X	X	-	-	-	-
180	7.09	ISO	-	-	X	X	-	X	X	X	-	-	-
184	7.25	ANSI	-	X	X	X	X	X	X	-	-	-	-
203	8.00	MISC	-	-	-	-	-	-	-	X	-	-	-
218	8.59	MISC	-	-	-	-	-	-	X	-	-	-	-
219	8.62	MISC	-	-	-	-	X	X	-	-	-	-	-
226	8.88	MISC	-	-	-	-	-	-	-	X	-	-	-
248	9.75	ANSI	-	-	-	-	X	X	X	X	X	-	-
250	9.84	ISO	-	-	-	-	-	-	-	X	X	-	-
252	9.94	MISC	-	-	-	-	-	-	X	-	-	-	-
282	11.09	MISC	-	-	-	-	-	X	-	-	-	-	-
311	12.25	ANSI	-	-	-	-	X	X	X	-	-	-	-
357	14.05	MISC	-	-	-	-	-	-	-	-	X	-	-

Table 6

Moment of inertia

Size

Horizontal

Vertical

Size	Horizontal	Vertical
-	kg/m ²	kg/m ²
1020	0,0014	0,0016
1030	0,0022	0,0024
1040	0,0033	0,0035
1050	0,0072	0,0074
1060	0,012	0,011
1070	0,019	0,017
1080	0,045	0,042
1090	0,079	0,079
1100	0,179	0,179
1110	0,270	0,270
1120	0,512	0,486
1130	0,99	1,065
1140	1,85	1,89
1150	3,49	3,29
1160	5,82	6,01
1170	10,41	10,42
1180	18,30	-
1190	26,17	-
1200	43,55	-

The values are based on hubs with no bore.

Table 7

Order data

Coupling type	Hubs	Qty	Bored to size*	Cover	Qty	Grid	Qty	Spacer hub set	Qty
-	Solid bore			-		-		(... = DBSE dimension)	
Horizontal split cover	PHE 1050TGRSB	2 or	PHE 1050TG ... MM	2	PHE 1050TGHCOVER	1	PHE 1050TGGRID	1	-
Vertical split cover	PHE 1050TGRSB	2 or	PHE 1050TG ... MM	2	PHE 1050TGVCOVER	1	PHE 1050TGGRID	1	-
Full spacer	PHE 1050TG-SHRSB	2 or	PHE 1050TG-SH ... MM	2	PHE 1050TGHCOVER	1	PHE 1050TGGRID	1	PHE 1050TGFS-SPACERX ... MM
Half spacer	PHE 1050TG-SHRSB	1 or	PHE 1050TG-SH ... MM	1	PHE 1050TGHCOVER	1	PHE 1050TGGRID	1	PHE 1050TGHFS-SPACERX ... MM

* For bored to size designations, add bore size. For example, PHE 1050TG25MM

Order data

Full spacer and half spacer coupling types

Full spacer

Each complete coupling consists of: 2 hubs, 1 grid, 1 cover and 1 spacer hub set. The cover assembly kit is supplied with the cover. The spacer hub assembly kit is supplied with the spacer hub set.

Example: the following components should be ordered for a complete 1050 full spacer grid coupling with solid bore and a DBSE dimension of 155 mm (DBSE = distance between the shaft ends).

2 ea. PHE 1050TGS-SHR SB
1 ea. PHE 1050TGGRID
1 ea. PHE 1050TGHCOVER
1 ea. PHE 1050TGFS-SPACERX155MM

The following components should be ordered for a complete 1050 full spacer grid coupling, bored to size.

1 ea. PHE 1050TGS-SHX30MM
1 ea. PHE 1050TG-SHX40MM
1 ea. PHE 1050TGGRID
1 ea. PHE 1050TGHCOVER
1 ea. PHE 1050TGFS-SPACERX155MM

Half spacer

The following components should be ordered for a complete 1050TG half spacer grid coupling with solid bore and a DBSE dimension of 89 mm.

1 ea. PHE 1050TGS-SHR SB
1 ea. PHE 1050TGR SB
1 ea. PHE 1050TGGRID
1 ea. PHE 1050TGHCOVER
1 ea. PHE 1050TGHS-SPACERX89MM

Horizontal and vertical cover types

Each complete coupling consists of: 2 hubs, 1 grid and 1 cover. The assembly kit is supplied with the cover and includes oil seals, gasket, bolts and lock-nuts. To order the assembly kit separately, please use the basic number and add TGHKIT for the horizontal cover or TGVKIT for the vertical cover (e.g.: PHE 1050TGHKIT)

Example: the following components should be ordered for a complete 1050 horizontal grid coupling with a solid bore.

2 ea. PHE 1050TGR SB
1 ea. PHE 1050TGGRID
1 ea. PHE 1050TGHCOVER
(PHE 1050TGVCOVER for vertical cover)

The following components should be ordered for a complete 1050 horizontal grid coupling, bored to size.

1 ea. PHE 1050TGX30MM
1 ea. PHE 1050TGX40MM
1 ea. PHE 1050TGGRID
1 ea. PHE 1050TGHCOVER

Note

For coupling sizes 1020 to 1090, SKF will supply the requested bore size with a clearance fit and standard keyways unless otherwise specified. For sizes 1100 and above, interference fit with standard keyways will be supplied unless otherwise specified.

Installation

The performance of the coupling depends largely upon how it is installed, aligned and maintained.

SKF Grid Couplings are designed to operate in either a horizontal or a vertical position without modification.

1 Mount the seals and the hubs

Clean all metal parts using non-flammable solvent and check hubs, shafts and keyways for burrs and remove if necessary. Lightly coat the seals with grease and place well back on the shafts before mounting the hubs. Mount the hubs on their respective shafts so that each hub face is flush with the end of the shafts (1).

2 Gap and angular alignment

Using a feeler gauge equal in thickness to the gap specified in **table 4** on **page 6**. Insert the gauge as shown in image **2** to the same depth at 90° intervals and measure the clearance between the gauge and hub face. The difference in the minimum and the maximum measurements must not exceed the angular limits specified in **table 4** on **page 6**.

3 Offset alignment

Align the two hubs so that a straight edge rests squarely on both hubs and also at 90° intervals (3). The clearance must not exceed the parallel offset installation limits specified in **table 4** on **page 6**. Tighten all foundation bolts and repeat **steps 2** and **3**. Realign the application if necessary.

4 Mount the grid

Pack the gap and all of the grooves in the two hubs with a specified lubricant (→ **page 62**) before mounting the grid. Fit the grid over the hubs by starting at one cut end, work the coils of the grid tooth by tooth in one direction and seat firmly as you go with a soft mallet (4).

5 Pack with grease and assemble the covers

Pack the spaces between and around the grid with as much lubricant as possible and wipe off the excess so that it is flush with the top of the grid (5). Position the seals on hubs so they line up with the grooves in the cover. Position gaskets on the flanges of the lower cover half and assemble the covers so that the match marks are on the same side. Push gaskets in until they stop against the seals and secure cover halves with the fasteners provided and tighten them accordingly. Make sure that the gaskets stay in position during this tightening procedure (7). Once the coupling is completely assembled, remove both of the lubrication plugs in the cover and insert a lubrication fitting. Then, pump in the appropriate lubricant until it is forced out of the opposite lubrication hole (8). Replace the two lubrication plugs and the installation is complete.

Grid removal

Whenever it is necessary to replace the grid, first remove the cover halves and set aside. Beginning at the cut end of the grid, carefully insert a screwdriver into the loop (9). Using the hub teeth for leverage, gradually pry the grid up, alternating sides while working around the coupling.

SKF does not recommend re-using the removed grid.

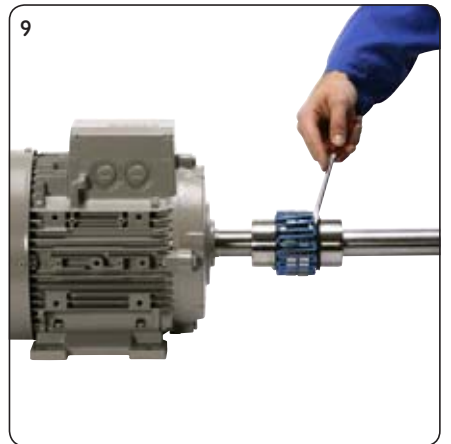
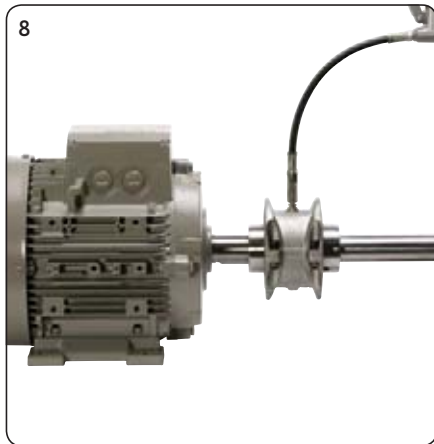
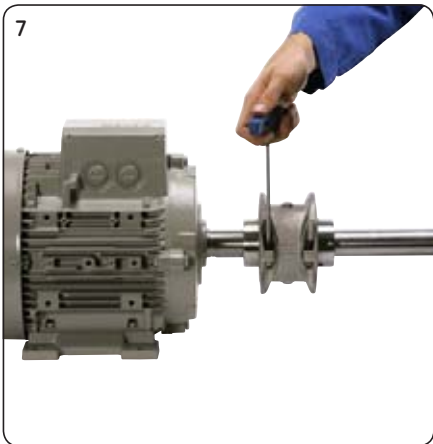
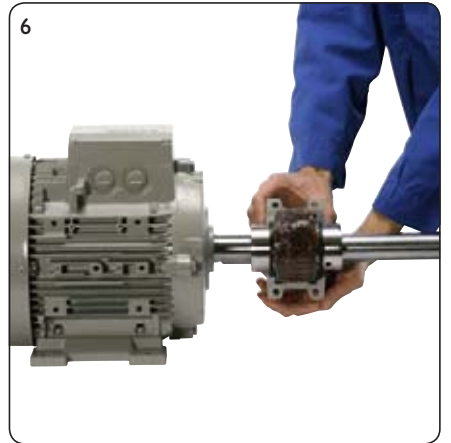
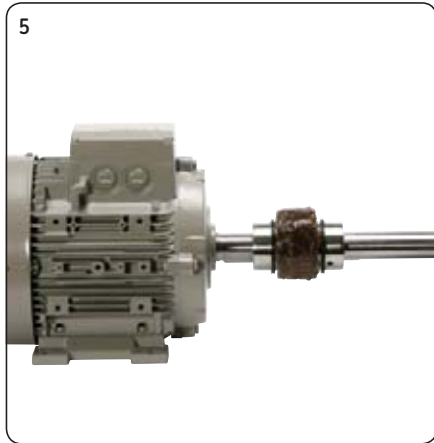
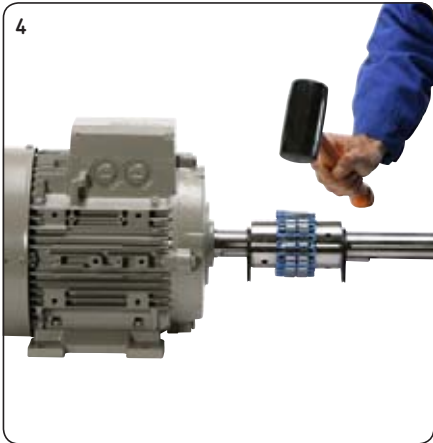
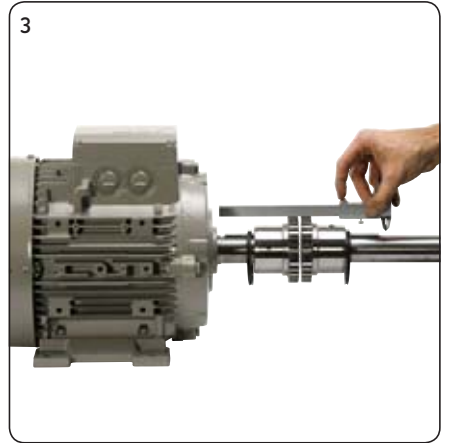
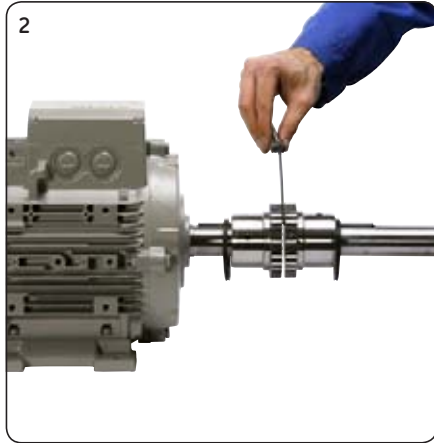
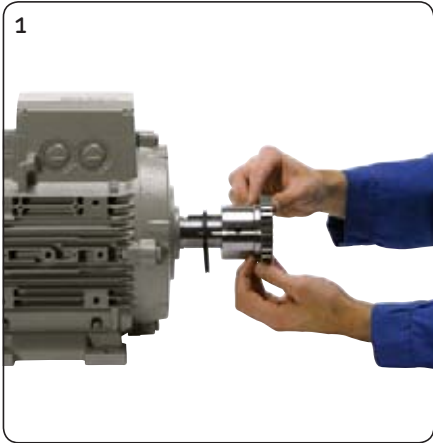

Horizontal split cover

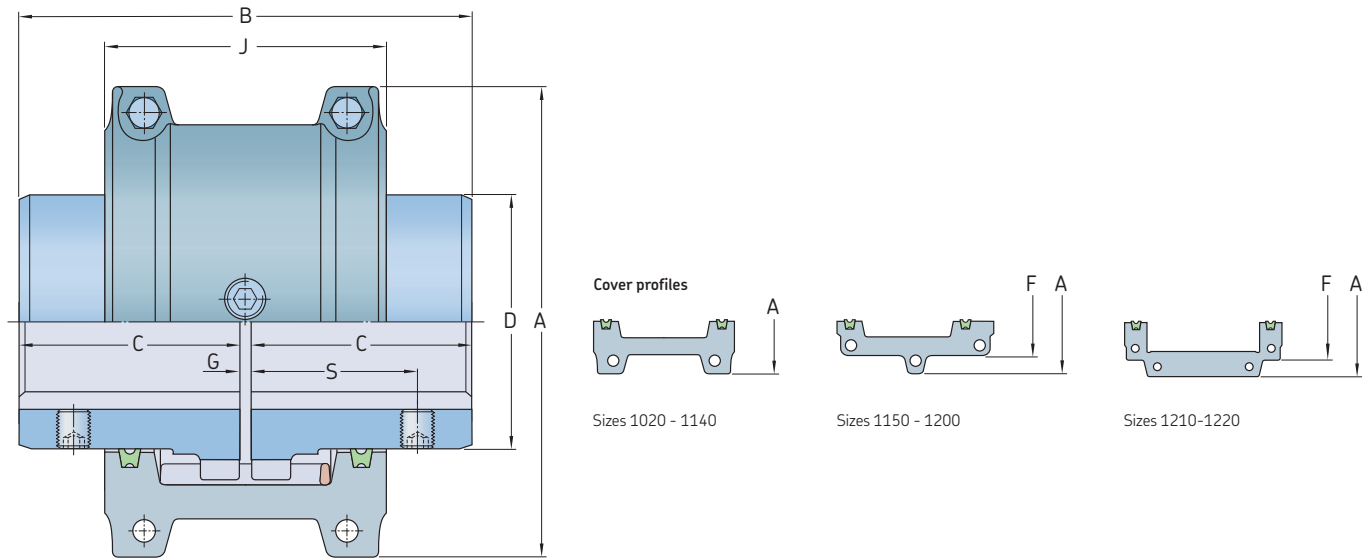

Size	Power per 100 r/min	Rated torque	Max speed	Bore diameter		Dimensions							G gap			Lubricant weight	Coupling weight without bore
				min.	max.	A	B	C	D	J	F	S	min.	Normal	max.		
–	kW	Nm	r/min	mm		mm							mm			kg	kg
1020 TGH	0,54	52	4 500	12	30	101,6	98,2	47,5	39,7	66	–	39,1	1,5	3	4,5	0,027	1,9
1030 TGH	1,6	149	4 500	12	36	110	98,2	47,5	49,2	68,3	–	39,1	1,5	3	4,5	0,040	2,6
1040 TGH	2,6	249	4 500	12	44	117,5	104,6	50,8	57,2	70	–	40,1	1,5	3	4,5	0,054	3,4
1050 TGH	4,6	435	4 500	12	50	138	123,6	60,3	66,7	79,5	–	44,7	1,5	3	4,5	0,068	5,4
1060 TGH	7,2	684	4 500	19	57	150,5	130,0	63,5	76,2	92	–	52,3	1,5	3	4,5	0,086	7,3
1070 TGH	10,4	994	4 125	19	65	161,9	155,4	76,2	87,3	95	–	53,8	1,5	3	4,5	0,113	10
1080 TGH	21,5	2 050	3 600	27	79	194	180,8	88,9	104,8	116	–	64,5	1,5	3	6	0,172	18
1090 TGH	39,0	3 730	3 600	27	95	213	199,8	98,4	123,8	122	–	71,6	1,5	3	6	0,254	25
1100 TGH	65,7	6 280	2 440	41	107	250	246,2	120,6	142,1	155,5	–	–	1,5	5	9,5	0,426	42
1110 TGH	97,6	9 320	2 250	41	117	270	259,0	127,0	160,3	161,5	–	–	1,5	5	9,5	0,508	54
1120 TGH	143,0	13 700	2 025	60	136	308	304,4	149,2	179,4	191,5	–	–	1,5	6	12,5	0,735	81
1130 TGH	208,0	19 900	1 800	66	165	346	329,8	161,9	217,5	195	–	–	1,5	6	12,5	0,907	121
1140 TGH	299,0	28 600	1 650	66	184	384	374,4	184,2	254,0	201	–	–	1,5	6	12,5	1,13	178
1150 TGH	416,0	39 800	1 500	108	203	453,1	371,8	182,9	269,2	271,3	391,2	–	1,5	6	12,5	1,95	234
1160 TGH	586,0	55 900	1 350	120	228	501,4	402,2	198,1	304,8	278,9	436,9	–	1,5	6	12,5	2,81	317
1170 TGH	781,0	74 600	1 225	133	279	566,4	437,8	215,9	355,6	304,3	487,2	–	1,5	6	12,5	3,49	448
1180 TGH	1 080,0	103 000	1 100	152	311	629,9	483,6	238,8	393,7	321,1	554,7	–	1,5	6	12,5	3,76	619
1190 TGH	1 430,0	137 000	1 050	152	339	675,6	524,2	259,1	436,9	325,1	607,8	–	1,5	6	12,5	4,40	776
1200 TGH	1 950,0	186 000	900	177	361	756,9	564,8	279,4	497,8	355,6	660,4	–	1,5	6	12,5	5,62	1 057
1210 TGH	2 611,0	249 000	820	177	390	844,5	622,3	304,8	533,4	431,8	750,8	–	1,5	6	12,7	10,5	1 425
1220 TGH	3 523,0	336 000	730	203	420	920,7	662,9	325,1	571,5	490,2	822,2	–	1,5	6	12,7	16,1	1 785

Horizontal split cover couplings are high performance, general purpose and easy to maintain. The grid is designed to be replaced without disturbing any other component in the drive.

Vertical split cover

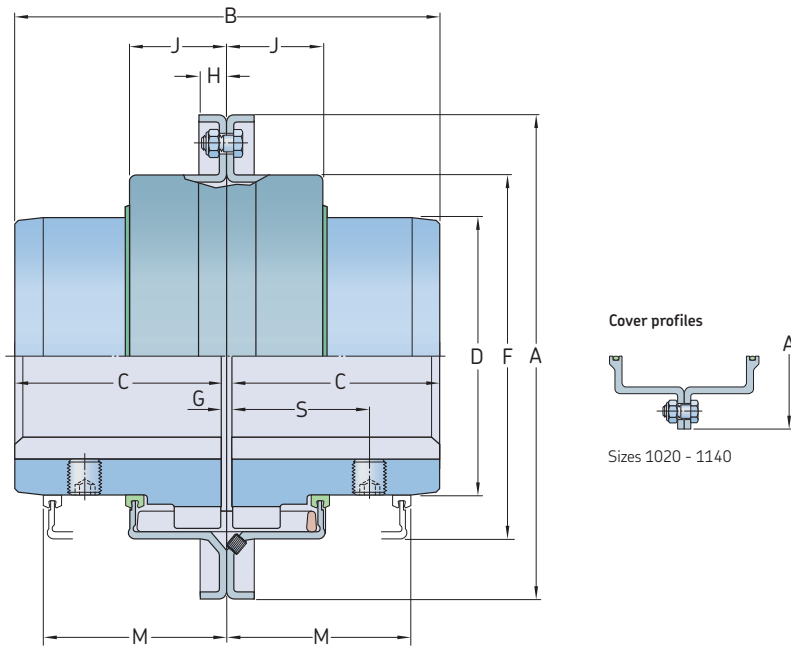

Size	Power per 100 r/min	Rated torque	Max speed	Bore diameter		Dimensions											G gap			Lubricant weight	Coupling weight without bore
				min.	max.	A	B	C	D	F	H	J	M	S	min.	Normal	Max.				
–	kW	Nm	r/min	mm		mm											mm			kg	kg
1020 TGV	0,54	52	6 000	12	30	111,1	98,0	47,5	39,7	64,3	9,7	24,2	47,8	39,1	1,5	3	4,5	0,027	2,0		
1030 TGV	1,6	149	6 000	12	36	120,7	98,0	47,5	49,2	73,8	9,7	25,0	47,8	39,1	1,5	3	4,5	0,040	2,6		
1040 TGV	2,6	249	6 000	12	44	128,5	104,6	50,8	57,2	81,8	9,7	25,7	50,8	40,1	1,5	3	4,5	0,054	3,4		
1050 TGV	4,6	435	6 000	12	50	147,6	123,6	60,3	66,7	97,6	11,9	31,2	60,5	44,7	1,5	3	4,5	0,068	5,4		
1060 TGV	7,2	684	6 000	19	57	162,0	130,0	63,5	76,2	111,1	12,7	32,2	63,5	52,3	1,5	3	4,5	0,086	7,3		
1070 TGV	10,4	994	5 500	19	65	173,0	155,4	76,2	87,3	122,3	12,7	33,7	66,5	53,8	1,5	3	4,5	0,113	10		
1080 TGV	21,5	2 050	4 750	27	79	200,0	180,8	88,9	104,8	149,2	12,7	44,2	88,9	64,5	1,5	3	6	0,172	18		
1090 TGV	39,0	3 730	4 000	27	95	231,8	199,8	98,4	123,8	168,3	12,7	47,7	95,2	71,6	1,5	3	6	0,254	25		
1100 TGV	65,7	6 280	3 250	41	107	266,7	245,7	120,6	142,1	198,0	15,7	60,0	120,7	–	1,5	5	9,5	0,426	42		
1110 TGV	97,6	9 320	3 000	41	117	285,8	258,5	127,0	160,3	216,3	16,0	64,2	124,0	–	1,5	5	9,5	0,508	54		
1120 TGV	143,0	13 700	2 700	60	136	319,0	304,4	149,2	179,4	245,5	17,5	73,4	142,7	–	1,5	6	12,5	0,735	81		
1130 TGV	208,0	19 900	2 400	66	165	377,8	329,8	161,9	217,5	283,8	20,6	75,1	146,0	–	1,5	6	12,5	0,907	122		
1140 TGV	299,0	28 600	2 200	66	184	416,0	371,6	184,2	254,0	321,9	20,6	78,2	155,4	–	1,5	6	12,5	1,13	180		
1150 TGV	416,0	39 800	2 000	108	203	476,3	371,8	182,9	269,2	374,4	19,3	106,9	203,2	–	1,5	6	12,5	1,95	230		
1160 TGV	586,0	55 900	1 750	120	228	533,4	402,2	198,1	304,8	423,9	30,0	114,3	215,9	–	1,5	6	12,5	2,81	321		
1170 TGV	781,0	74 600	1 600	133	279	584,2	437,8	215,9	355,6	474,7	30,0	119,4	226,1	–	1,5	6	12,5	3,49	448		
1180 TGV	1 080,0	103 000	1 400	152	311	630,0	483,6	238,8	393,7	–	–	130,0	265,0	–	1,5	6	12,5	3,76	591		
1190 TGV	1 430,0	137 000	1 300	152	339	685,0	524,2	259,1	436,9	–	–	135,0	275,0	–	1,5	6	12,5	4,40	761		
1200 TGV	1 950,0	186 000	1 100	177	361	737,0	564,8	279,4	497,8	–	–	145,0	295,0	–	1,5	6	12,5	5,62	1 021		

Vertical split cover couplings are high performance, general purpose and easy to maintain. The grid is designed to be replaced without disturbing any other component in the drive. The vertical cover allows for higher running speeds.

Full spacer

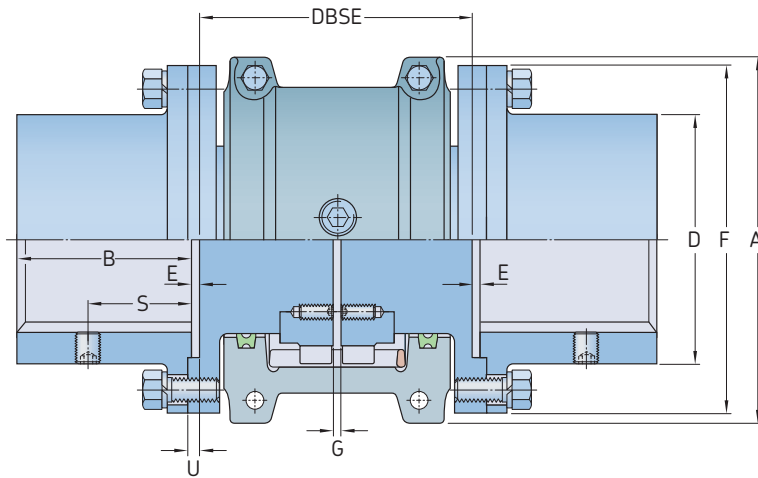

Size	Power per 100 r/min	Rated torque	Max speed	Bore diameter		Dimensions										G gap		Flange bolts	Lubricant weight	Coupling weight without bore and min. DBSE
				min.	max.	A	B	DBSE min.	DBSE max.	D	E	F	S	U	min.	Normal				
	kW	Nm	r/min	mm		mm										mm		Quantity	kg	kg
1020 TGFS	0,54	52	3 600	12	35	101,6	35	89	203	52	0,8	86	27,4	1,8	1,5	5	4	0,027	3,9	
1030 TGFS	1,6	149	3 600	12	43	110	41	89	216	59	0,8	94	31,5	1,8	1,5	5	8	0,040	5,2	
1040 TGFS	2,6	249	3 600	12	56	117,5	54	89	216	78	0,8	113	27,4	1,8	1,5	5	8	0,054	8,4	
1050 TGFS	4,6	435	3 600	12	67	138	60	112	216	87	0,8	126	40,6	1,8	1,5	5	8	0,068	12,8	
1060 TGFS	7,2	684	3 600	19	80	150,5	73	127	330	103	1,8	145	43,2	2,8	1,5	5	8	0,086	20,5	
1070 TGFS	10,4	994	3 600	19	85	161,9	79	127	330	109	1,8	153	46,7	2,8	1,5	5	12	0,113	24,8	
1080 TGFS	21,5	2 050	3 600	27	95	194	89	184	406	122	1,8	178	49,8	2,8	1,5	5	12	0,172	40	
1090 TGFS	39,0	3 730	3 600	27	110	213	102	184	406	142	1,8	210	56,9	2,8	1,5	5	12	0,254	60	
1100 TGFS	65,7	6 280	2 440	41	130	250	90	203	406	171	1,6	251	–	3,2	1,5	6,5	12	0,426	90,2	
1110 TGFS	97,6	9 320	2 250	41	150	270	104	210	406	196	1,6	277	–	3,2	1,5	6,5	12	0,508	119	
1120 TGFS	143,0	13 700	2 025	60	170	308	119	246	406	225	1,6	319	–	4	1,5	9,5	12	0,735	178	
1130 TGFS	208,0	19 900	1 800	66	190	346	135	257	406	238	1,6	346	–	4	1,5	9,5	12	0,907	237	
1140 TGFS	299,0	28 600	1 650	66	210	384	152	267	406	266	1,6	386	–	4	1,5	9,5	12	1,13	327	
1150 TGFS	416,0	39 800	1 500	108	270	453,1	173	345	371	334	5,1	425	–	–	1,5	9,5	14	1,95	462	
1160 TGFS	586,0	55 900	1 350	120	290	501,4	186	356	406	366	6,6	457	–	–	1,5	9,5	14	2,81	566	
1170 TGFS	781,0	74 600	1 225	133	340	566,4	220	384	445	425	8,4	527	–	–	1,5	9,5	16	3,49	856	
1180 TGFS	1 080,0	103 000	1 100	133	340	629,9	249	400	490	451	5,1	591	–	8,1	1,5	9,5	16	3,76	1 135	
1190 TGFS	1 430,0	137 000	1 050	152	380	675,6	276	411	530	508	5,1	660	–	8,1	1,5	9,5	18	4,40	1 525	
1200 TGFS	1 950,0	186 000	900	177	400	756,9	305	445	575	530	6,1	711	–	9,1	1,5	9,5	18	5,62	1 910	

SKF horizontal split cover full spacer couplings are designed to accommodate long distances between the shafts that are to be connected. This coupling gives you the added advantage of being able to drop out the entire centre section of the coupling for easy service. This coupling is an ideal choice for pumps.

Half spacer

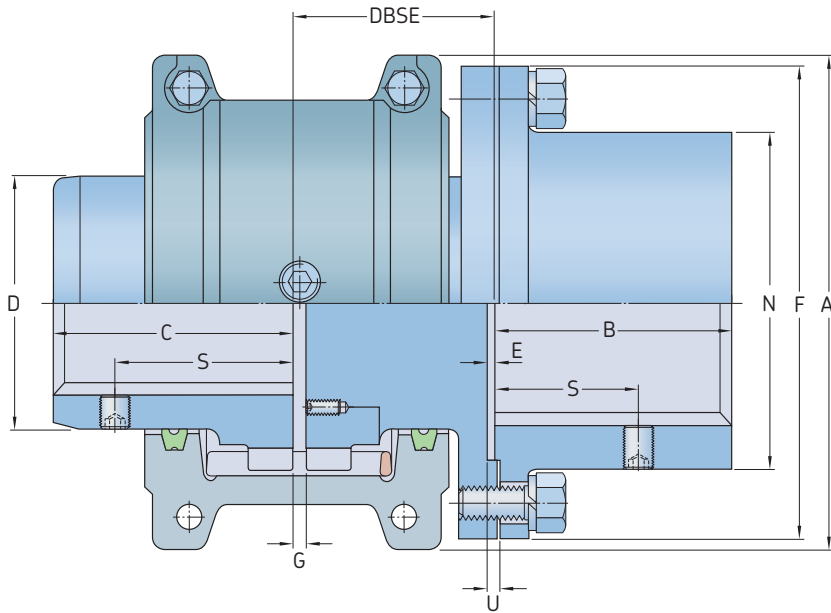

Size	Power per 100 r/min	Rated torque	Max speed	Bore diameter			Dimensions										G gap			Flange bolts	Lubricant weight	Coupling weight without bore	
				min.	max.	Max shaft hub	A	B	C	D	DBSE min.	DBSE max.	N	E	F	S shaft hub	S T hub	U	min.				normal
–	kW	Nm	r/min	mm			mm										mm				kg	kg	
1020 TGHS	0,54	52	3 600	12	30	35	101,6	35	47,5	39,7	45	102	52	0,8	86	27,4	39,1	1,8	1,5	3	4	0,027	2,9
1030 TGHS	1,6	149	3 600	12	36	43	110	41	47,5	49,2	45	109	59	0,8	94	31,5	39,1	1,8	1,5	3	8	0,040	3,9
1040 TGHS	2,6	249	3 600	12	44	56	117,5	54	50,8	57,2	45	109	78	0,8	113	27,4	40,1	1,8	1,5	3	8	0,054	5,9
1050 TGHS	4,6	435	3 600	12	50	67	138	60	60,3	66,7	57	109	87	0,8	126	40,6	44,7	1,8	1,5	3	8	0,068	9,1
1060 TGHS	7,2	684	3 600	19	57	80	150,5	73	63,5	76,2	64	166	103	1,8	145	43,2	52,3	2,8	1,5	3	8	0,086	14
1070 TGHS	10,4	994	3 600	19	65	85	161,9	79	76,2	87,3	64	166	109	1,8	153	46,7	53,8	2,8	1,5	3	12	0,113	17,6
1080 TGHS	21,5	2 050	3 600	27	79	95	194	89	88,9	104,8	93	204	122	1,8	178	49,8	64,5	2,8	1,5	3	12	0,172	29
1090 TGHS	39,0	3 730	3 600	27	95	110	213	102	98,4	123,8	93	204	142	1,8	210	56,9	71,6	2,8	1,5	3	12	0,254	42,8
1100 TGHS	65,7	6 280	2 440	41	107	130	250	90	120,6	142,1	103	205	171	1,6	251	–	–	3,2	1,5	5	12	0,426	66
1110 TGHS	97,6	9 320	2 250	41	117	150	270	104	127,0	160,3	106	205	196	1,6	277	–	–	4	1,5	6	12	0,508	84,5
1120 TGHS	143,0	13 700	2 025	60	136	170	308	119	149,2	179,4	125	205	225	1,6	319	–	–	4	1,5	6	12	0,735	129
1130 TGHS	208,0	19 900	1 800	66	165	190	346	135	161,9	217,5	130	205	238	1,6	346	–	–	4	1,5	6	12	0,907	179
1140 TGHS	299,0	28 600	1 650	66	184	210	384	152	184,2	254,0	135	205	266	1,6	386	–	–	4	1,5	6	12	1,13	252
1150 TGHS	416,0	39 800	1 500	108	203	270	453,1	173	182,9	269,2	175	187	334	5,1	425	–	–	–	1,5	6	14	1,95	348
1160 TGHS	586,0	55 900	1 350	120	228	290	501,4	186	198,1	304,8	180	205	366	6,6	457	–	–	–	1,5	6	14	2,81	441
1170 TGHS	781,0	74 600	1 225	133	279	340	566,4	220	215,9	355,6	194	224	425	8,4	527	–	–	–	1,5	6	16	3,49	652
1180 TGHS	1 080,0	103 000	1 100	133	311	340	629,9	249	238,8	393,7	202	247	451	5,1	591	–	–	8,1	1,5	6	16	3,76	877
1190 TGHS	1 430,0	137 000	1 050	152	339	380	675,6	276	259,1	436,9	207	267	508	5,1	660	–	–	8,1	1,5	6	18	4,40	1 150
1200 TGHS	1 950,0	186 000	900	177	361	400	756,9	305	279,4	497,8	224	289	530	6,1	711	–	–	9,1	1,5	6	18	5,62	1 484

SKF horizontal split cover half spacer couplings are designed to be used where there is no need to accommodate long distances between the shafts. It provides an economical alternative to the full spacer and is an ideal choice for pumps.

SKF Gear Couplings

Very high-torque ratings, along with unparalleled bore capacities, give this coupling a great advantage over other types of couplings. SKF Gear Couplings are rated up to 555 000 Nm with a maximum bore of 4 495 mm. This is a heavy duty coupling with incredible design flexibility, making it an economical choice for many applications.

The unique design of the gear couplings tooth crowning dramatically reduces backlash and radial clearance. The hub bore capacities are the largest in the industry, allowing for low cost and long service life.

Selection

Standard selection method

This selection procedure can be used for most motor, turbine, or engine driven applications. The following information is required to select an SKF gear coupling:

- Torque – Power [kW]
- Speed [r/min]
- Type of equipment and application
- Shaft diameters
- Shaft gaps
- Physical space limitation
- Special bore or finish information

Exceptions to use of the standard selection method are for high peak loads and brake applications. For these, use the formula selection method or contact SKF.

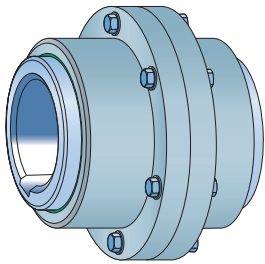

Double engagement → page 22

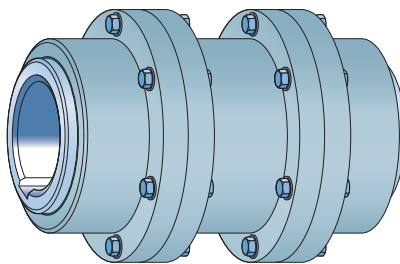

Double engagement spacer → page 24

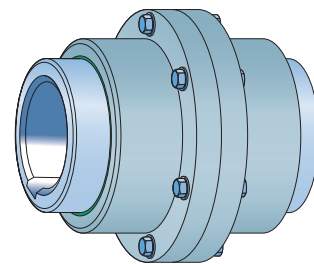

Slide single and double engagement → page 26 and 27

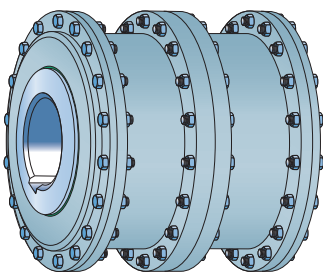

Double engagement → page 22

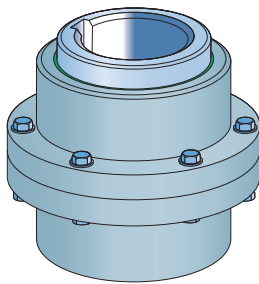

Vertical double engagement → page 25

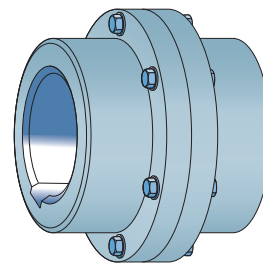

Rigid flanged sleeve → page 28

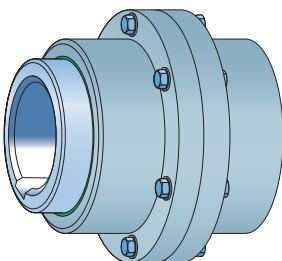

Single engagement → page 23



Floating and vertical shaft single engagement → page 32 and 33

1 Determine system torque

If torque is not given, use the following formula to calculate for torque (T)

System torque [Nm]=

$$\frac{\text{Power [kW]} \times 9\,549}{\text{Speed [r/min]}}$$

2 Service factor

Determine the service factor with **tables 7 and 8 on pages 60 and 61.**

3 Coupling rating

Determine the required minimum coupling rating as shown below:

Coupling rating =
service factor × torque [Nm]

4 Size

Select the appropriate coupling from the torque column of the product tables on pages 22 to 28 with a value that is equal to or greater than that determined in step 3 above and check that the chosen coupling can accommodate both driving and driven shafts.

5 Other considerations

Possible other restrictions might be speed [r/min], bore, gap and dimensions.

Standard selection example

Select a coupling to connect the low speed shaft of an ore conveyor drive to a speed reducer. The 350 kW, 1 440 r/min electric motor is driving the reducer with an output speed of 38 r/min. The reducer low speed shaft diameter is 215 mm, the conveyor head shaft is 225 mm. Shaft extensions are both 280 mm.

1 Determine system torque

System torque [Nm] =

$$\frac{350 \text{ kW} \times 9\,549}{38 \text{ r/min}} = 87\,997 \text{ Nm}$$

2 Service factor

From **table 7** on **page 60** = 1,00

3 Required coupling rating

$$1,00 \times 87\,951 \text{ Nm} = 87\,951 \text{ Nm}$$

4 Size

From product table on **page 22**, the coupling size 60 is the proper selection based on the torque rating of 90 400 Nm which exceeds the required minimum rating of 87 951 Nm.

5 Other considerations

The speed capacity of 2 450 (coupling size 60) exceeds the required speed of 38 r/min. The maximum bore capacity of 244 mm exceeds the required shaft diameters of 215 mm and 225 mm. The minimum required shaft length (J) of 169 mm is exceeded by the equipment's shaft extensions of 280 mm. The resulting service factor is 1,03.

Formula method

The standard selection method can be used for most coupling selections. However, the formula method should be used for:

- high peak loads
- brake applications (If a brake wheel is to be an integral part of the coupling)

By including the system's peak torque, frequency, duty cycle and brake torque ratings, a more accurate result will be obtained.

1 High peak loads

Use one of the following formulas (A, B, or C) for:

- Motors with higher than normal torque characteristics.
- Applications with intermittent operations shock loading.
- Inertia effects due to frequent stops and starts or repetitive high peak torques.

Peak torque is the maximum torque that can exist in the system. Select a coupling with a torque rating equal to or exceeding the selection torque from the relevant formula below.

A Non-reversing peak torque

Selection torque [Nm] =
System peak torque

or

Selection torque [Nm] =

$$\frac{\text{System peak kW} \times 9\,549}{\text{r/min}}$$

B Reversing high peak torque

Selection torque [Nm] =

$$\frac{1,5 \times \text{system peak torque}}{\text{r/min}}$$

C Occasional peak torques (non-reversing)

If a system peak torque occurs less than 1 000 times during the expected coupling life, use the following formula:

Selection torque [Nm] =
0,5 × system peak torque

or

Selection torque [Nm] =

$$\frac{0,5 \times \text{system peak kW} \times 9\,549}{\text{r/min}}$$

2 Brake applications

If the torque rating of the brake exceeds the motor torque, use the brake rating as follows:

Selection torque [Nm] =
Brake torque rating × Service factor.

Formula selection example

High peak load

Select a coupling for reversing service to connect a gear drive low speed shaft to a metal forming mill drive. The electric motor rating is 30 kW and the system peak torque estimated to be 9 000 Nm. Coupling speed is 66 r/min at the motor base speed. The drive shaft diameter is 90 mm. The metal forming mill drive shaft diameter is 120 mm.

1 Type

Refer to **page 20** and select the appropriate coupling type.

2 Required minimum coupling rating

Use the reversing high peak torque formula in step 1B.

$$1,5 \times 9\,000 \text{ Nm} = 13\,500 \text{ Nm} = \text{Selection torque}$$

3 Size

From product table on **page 22**, size 35 with a torque rating of 18 500 exceeds the selection torque of 13 500 Nm.

4 Other considerations

Gear coupling size 35 has a maximum bore capacity of 124 mm from product table on **page 22** and the allowable speed of 3 900 r/min exceeds the equipment requirements.

Engineering data

These maximum operating alignment limits are each based on $3/4^\circ$ per flex half coupling. Combined values of parallel and angular misalignment should not exceed $3/4^\circ$. Type GC slide couplings are limited to $1/4^\circ$ per flex half.

Do not use single engagement couplings to compensate for parallel offset misalignment.

For additional information about gear couplings, such as puller bolt hole data, please refer to **tables 1** and **2**.

Order data

A complete gear coupling consists of: 2 hubs, 2 covers and 1 assembly kit.

Coupling size 80 and above consists of: 2 hubs, 1 male cover, 1 female cover and 1 assembly kit. For more detailed information on ordering specific gear couplings, refer to **table 3**.

Table 1

Puller bolt hole data

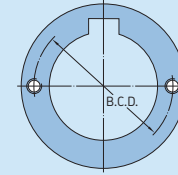

Size Flex hub	B.C.D. mm	Bolt size
10	–	–
15	–	–
20	89	M8
25	112	M10
30	128	M10
35	152	M12
40	181	M16
45	200	M16
50	216	M20
55	235	M20
60	268	M20
70	305	M24
80	318	M24
90	356	M30
100	394	M30
110	426	M30
120	498	M30

Bore tolerances recommended.
Steel couplings hub.

Table 2

Misalignment capability

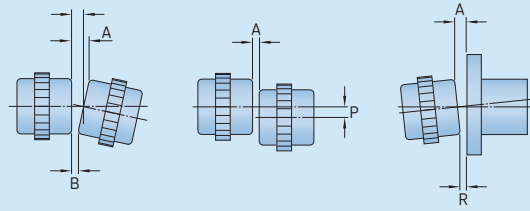

Size	Double engagement		Operating maximum*		Coupling gap Normal gap +/- 10%	Single engagement		Coupling gap Normal gap +/- 10%
	Installation maximum Parallel offset (P)	Angular offset (A-B)	Installation maximum Parallel offset (P)	Angular offset (A-B)		Installation maximum Angular offset (A-B)	Operating maximum* Angular offset (A-B)	
–	mm		mm		mm	mm	mm	mm
10	0,05	0,15	0,66	1,8	3	0,15	0,89	4
15	0,08	0,18	0,86	2,26	3	0,18	1,14	4
20	0,08	0,23	1,02	2,74	3	0,23	1,37	4
25	0,10	0,28	1,27	3,43	5	0,28	1,70	5
30	0,13	0,33	1,52	3,99	5	0,33	2,01	5
35	0,15	0,38	1,83	4,65	6	0,38	2,34	6
40	0,18	0,46	2,13	5,49	6	0,46	2,74	7
45	0,20	0,51	2,39	6,15	8	0,51	3,07	8
50	0,23	0,56	2,72	6,65	8	0,56	3,33	9
55	0,28	0,61	3,12	7,32	8	0,61	3,66	9
60	0,28	0,66	3,35	7,98	8	0,66	3,99	10
70	0,33	0,79	3,94	9,32	10	0,79	4,65	13
80	0,41	0,81	2,46	4,83	10	0,81	2,41	13
90	0,43	0,91	2,64	5,49	13	0,91	2,74	14
100	0,48	1,02	2,97	6,15	13	1,02	3,07	16
110	0,56	1,14	3,30	6,81	13	1,14	3,40	16
120	0,58	1,24	3,50	7,49	13	1,24	3,73	16

Table 3

Order data								
Coupling type	Hubs	Qty	Cover	Qty	Assembly kit	Qty	Spacer/floating tube and kits ... = DBSE dimension	Qty
Double engagement	PHE 50GCRSB	2	PHE 50GCCOVER	2	PHE 50GCKIT	1	–	–
Size 80 and above	PHE 80GCRSB	2	PHE 80GCMCOVER	1	PHE 80GCKIT	1	PHE 80GCRRING	1
	–	–	PHE 80GFCOVER	1	–	–	–	–
Single engagement	PHE 50GCSERSB	1	PHE 50GCCOVER	2	PHE 50GCKIT	1	–	–
	PHE 50GCRSB	1	–	–	–	–	–	–
Size 80 and above	PHE 80GCSERSB	1	PHE 80GCMCOVER	1	PHE 80GCKIT	1	–	–
	PHE 80GCRSB	1	PHE 80GFCOVER	1	–	–	–	–
Double engagement spacer	PHE 50GCRSB	2	PHE 50GCCOVER	2	PHE 50GCKIT	2	PHE 50GCSPACER ... MM	1
Double engagement slide type 1, 2, 3	PHE 50GCSLT1RSB	2	PHE 50GLT1COVER	2	PHE 50GCKIT	1	PHE 50GCCPLATE	1
Note: each type ordered with all components is a complete coupling	PHE 50GCSLT2RSB	2	PHE 50GLT2COVER	2	PHE 50GCKIT	1	PHE 50GCCPLATE	1
	PHE 50GCSLT3RSB	2	PHE 50GLT3COVER	2	PHE 50GCKIT	1	PHE 50GCCPLATE	1
							PHE 50GLT3DISC	1
Single engagement slide type 3 and 2	PHE 50GCSLT2RSB	1	PHE 50GLT2COVER	2	PHE 50GCKIT	1	–	–
Note: each type ordered with all components is a complete coupling	PHE 50GCSERSB	1	–	–	–	–	–	–
	PHE 50GCSLT3RSB	1	PHE 50GLT3COVER	2	PHE 50GCKIT	1	–	–
	PHE 50GCSERSB	1	–	–	–	–	–	–
Single engagement floating shaft	PHE 50GCFERSB	2	PHE 50GCCOVER	2	PHE 50GCKIT	2	PHE 50GCFSHAFT ... MM	1
	PHE 50GCRSB	2	–	–	–	–	–	–
Double engagement vertical	PHE 50GCVRSB	2	PHE 50GCVCOVER	2	PHE 50GCKIT	1	50GCVTRKIT	1
Single engagement vertical	PHE 50GCVRSB	1	PHE 50GCVCOVER	2	PHE 50GCKIT	1	50GCVTRKIT	–
	PHE 50GCSERSB	1	–	–	–	–	–	–
Single engagement vertical floating	PHE 50GCVRSB	2	PHE 50GCVCOVER	2	PHE 50GCKIT	2	50GCVTRKIT	2
	PHE 50GCFERSB	2	–	–	–	–	–	–
	PHE 50GCVRSB	1	PHE 50GCVCOVER	2	PHE 50GCKIT	2	PHE 50GCFSHAFT ... MM	1
	PHE 50GCSERSB	1	–	–	–	–	–	–
Rigid flanged sleeve	PHE 50GCRRSB	2	–	–	PHE 50GCRKIT	1	PHE 50GCRRING	1

For bored to size designations, add bore size in mm. For example: PHE 50GCX500MM.

For shrouded bolt covers use cover number, e.g. PHE 50SGCCOVER and PHE 50SGCKIT for the assembly kit. The assembly kit includes oil seals, gasket, bolts and lock-nuts.

Installation

The performance of the coupling depends largely upon how it is installed, aligned and maintained.

1 Mount the flanged sleeves with the seal rings before the hubs

Clean all metal parts using non-flammable solvent and check hubs, shafts and keyways for burrs and remove if necessary. Lightly coat the seals with grease and place well back on the shafts before mounting the hubs. Mount the hubs on their respective shafts so that each hub face is flush with the end of the shaft unless otherwise indicated (1).

2 Gap and angular alignment

Use a feeler gauge equal in thickness to the gap specified in **table 3** on **page 19**. Insert the gauge as shown in image 2 to the same depth at 90° intervals and measure the clearance between the gauge and hub face. The difference in the minimum and the maximum measurements must not exceed the angular limits specified in **table 3** on **page 19**.

3 Offset alignment

Align the two hubs so that a straight edge rests squarely on both hubs as in image 3, and also at 90° intervals. The clearance must not exceed the parallel offset installation limits specified in **table 3** on **page 19**. Tighten all foundation bolts (4) and repeat steps 2 and 3. Realign the coupling if necessary.

4 Pack with grease and assemble the sleeves

Pack the gears of the hubs with grease. Insert the gasket between the sleeves and position the sleeves with the lubrication holes approximately 90° apart. Then push the sleeves into position and using the supplied fasteners, bolt the sleeves together. Once the coupling is assembled, remove the lubrication plugs from the sleeves. Insert a grease fitting in one of the holes and pump grease into the sleeve until it is forced out of the opposite lubrication holes (5). Replace the lubrication plugs. The installation is complete.

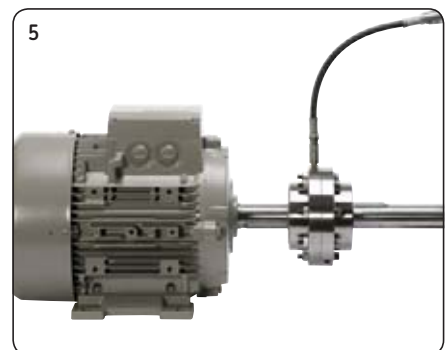
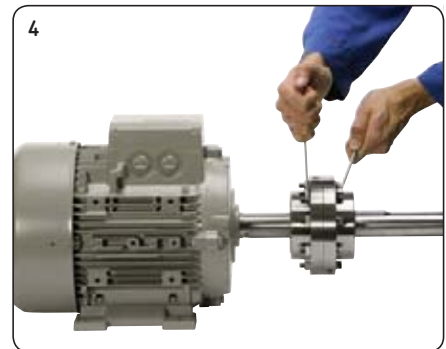
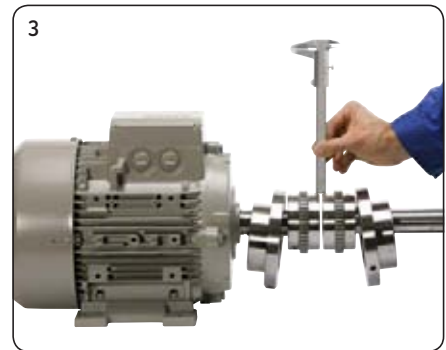
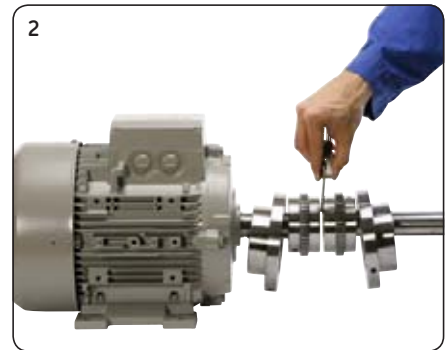

Double engagement

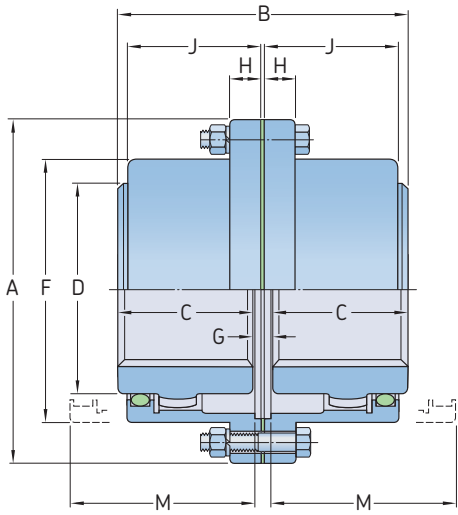

Size 10 to 70

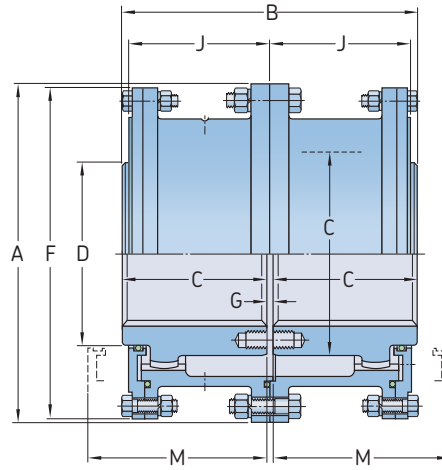

Size 80 to 120

Size	Power per 100 r/min	Rated torque	Max speed	Bore diameter		Dimensions								G gap min.	Lubricant weight kg	Coupling weight without bore kg
				min.	max.	A	B	C	D	F	H	J	M ¹⁾			
–	kW	Nm	r/min	mm		mm								mm	kg	kg
10 GC	11,9	1 139	8 000	13	48	116	89	43	69	84	14	39	51	3	0,04	5
15 GC	24,6	2 350	6 500	19	60	152	101	49	86	105	19	48	61	3	0,07	9
20 GC	44,7	4 270	5 600	25	73	178	127	62	105	126	19	59	77	3	0,12	16
25 GC	78,3	7 474	5 000	32	92	213	159	77	131	155	21,8	72	92	5	0,23	29
30 GC	127	12 100	4 400	38	105	240	187	91	152	180	21,8	84	107	5	0,36	43
35 GC	194	18 500	3 900	51	124	279	218	106	178	211	28,4	98	130	6	0,54	68
40 GC	321	30 609	3 600	64	146	318	248	121	210	245	28,4	111	145	6	0,91	97
45 GC	440	42 000	3 200	76	165	346	278	135	235	274	28,4	123	166	8	1,04	136
50 GC	593	56 600	2 900	89	178	389	314	153	254	306	38,1	141	183	8	1,77	190
55 GC	775	74 030	2 650	102	197	425	344	168	279	334	38,1	158	204	8	2,22	249
60 GC	947	90 400	2 450	114	222	457	384	188	305	366	25,4	169	229	8	3,18	306
70 GC	1 420	135 000	2 150	127	254	527	452	221	343	425	28,4	196	267	10	4,35	485
80 GC	1 780	170 000	1 750	102	279	591	508	249	356	572	–	243	300	10	9,53	703
90 GC	2 360	226 000	1 550	114	305	660	565	276	394	641	–	265	327	13	12,25	984
100 GC	3 250	310 000	1 450	127	343	711	623	305	445	699	–	294	356	13	14,97	1 302
110 GC	4 320	413 000	1 330	140	387	775	679	333	495	749	–	322	384	13	17,69	1 678
120 GC	5 810	555 000	1 200	152	425	838	719	353	546	826	–	341	403	13	20,87	2 114

¹⁾ Minimum clearance required for aligning coupling.

Double engagement couplings are designed for most horizontal, close coupled applications. This coupling accommodates both offset and angular misalignment, as well as end float. Applications include: fans, pumps, steel and paper mill drives, cranes and conveyors.

Double engagement Spacer

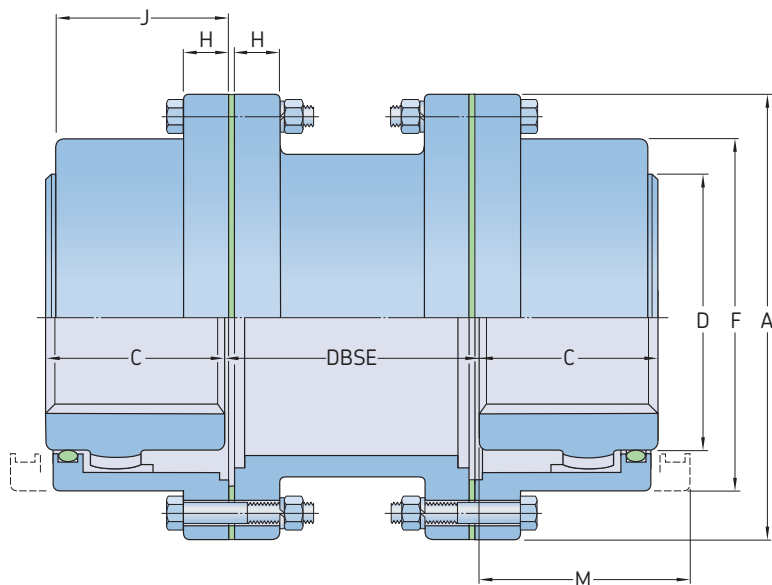

Size	Power per 100 r/min	Rated torque	Max speed	DBSE		Bore diameter		Dimensions						Lubricant weight	Coupling weight without bore and min. DBSE			
				min	max.	min.	max.	A	C	D	F	H	J			M ¹⁾		
–	kW	Nm	r/min	mm	mm	mm	mm	mm	mm	mm	mm	mm	mm	mm	mm	mm	kg	kg
10 GCS	11,9	1 139	7 000	83	311	13	48	116	43	69	84	14	39	51	0,04	6,8		
15 GCS	24,6	2 350	5 500	83	311	19	60	152	49	86	105	19	48	61	0,07	13,6		
20 GCS	44,7	4 270	4 600	83	311	25	73	178	62	105	126	19	59	77	0,12	20,4		
25 GCS	78,3	7 474	4 000	95	311	32	92	213	77	131	155	21,8	72	92	0,23	38,6		
30 GCS	127	12 100	3 600	95	311	38	105	240	91	152	180	21,8	84	107	0,36	54,4		
35 GCS	194	18 500	3 100	120	311	51	124	279	106	178	211	28,4	98	130	0,54	88,5		
40 GCS	321	30 609	2 800	120	311	64	146	318	121	210	245	28,4	111	145	0,91	122,5		
45 GCS	440	42 000	2 600	120	311	76	165	346	135	235	274	28,4	123	166	1,04	165,6		
50 GCS	593	56 600	2 400	146	311	89	178	389	153	254	306	38,1	141	183	1,77	238,1		
55 GCS	775	74 030	2 200	146	311	102	197	425	168	279	334	38,1	158	204	2,22	306,2		
60 GCS	947	90 400	2 100	146	311	114	222	457	188	305	366	25,4	169	229	3,18	358,3		
70 GCS	1 420	135 000	1 800	146	311	127	254	527	221	343	425	28,4	196	267	4,35	562,5		

¹⁾ Minimum clearance required for aligning coupling.

Double engagement spacer couplings are designed for pump and compressor applications. The coupling consists of a standard double engagement coupling and a spacer tube which is available in various lengths.

Double engagement

Vertical

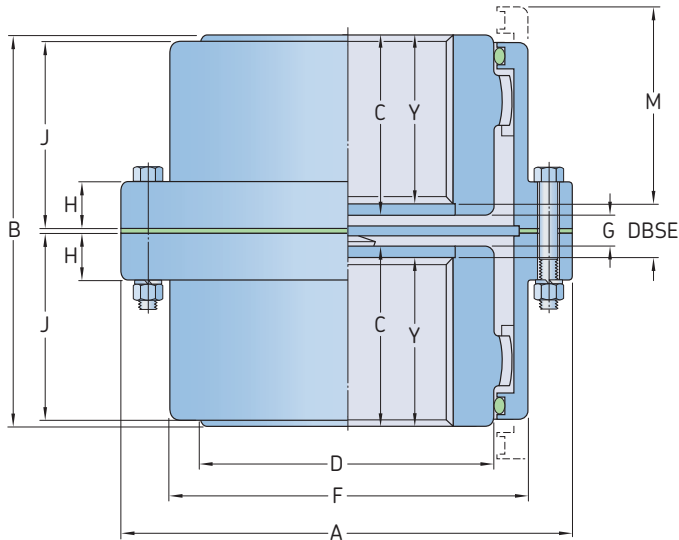

Size	Power per 100 r/min	Rated torque	Max speed	Bore diameter		Dimensions										G gap	Lubricant weight	Coupling weight without bore
				max.	min.	A	B	C	D	F	H	J	M ¹⁾	Y	DBSE			
–	kW	Nm	r/min	mm		mm										min.	kg	kg
10 GCV	11,9	1 139	8 000	13	48	116	89	43	69	84	14	39	51	32,5	24	11	0,04	5
15 GCV	24,6	2 350	6 500	19	60	152	101	49	86	105	19	48	61	38,6	24	11	0,07	9
20 GCV	44,7	4 270	5 600	25	73	178	127	62	105	126	19	59	77	51,3	24	11	0,12	16
25 GCV	78,3	7 474	5 000	32	92	213	159	77	131	155	21,8	72	92	65,3	26	14	0,23	29
30 GCV	127	12 100	4 400	38	105	240	187	91	152	180	21,8	84	107	79,8	26	14	0,36	43
35 GCV	194	18 500	3 900	51	124	279	218	106	178	211	28,4	98	130	94,0	30	18	0,54	68
40 GCV	321	30 609	3 600	64	146	318	248	121	210	245	28,4	111	145	105,9	35	22	0,91	97
45 GCV	440	42 000	3 200	76	165	346	278	135	235	274	28,4	123	166	116,3	44	25	1,04	136
50 GCV	593	56 600	2 900	89	178	389	314	153	254	306	38,1	141	183	134,6	44	25	1,77	190
55 GCV	775	74 030	2 650	102	197	425	344	168	279	334	38,1	158	204	149,6	44	25	2,22	249
60 GCV	947	90 400	2 450	114	222	457	384	188	305	366	25,4	169	229	168,1	48	29	3,18	306
70 GCV	1 420	135 000	2 150	127	254	527	452	221	343	425	28,4	196	267	194,8	61	35	4,35	485

¹⁾ Minimum clearance required for aligning coupling.

Double engagement

Slide

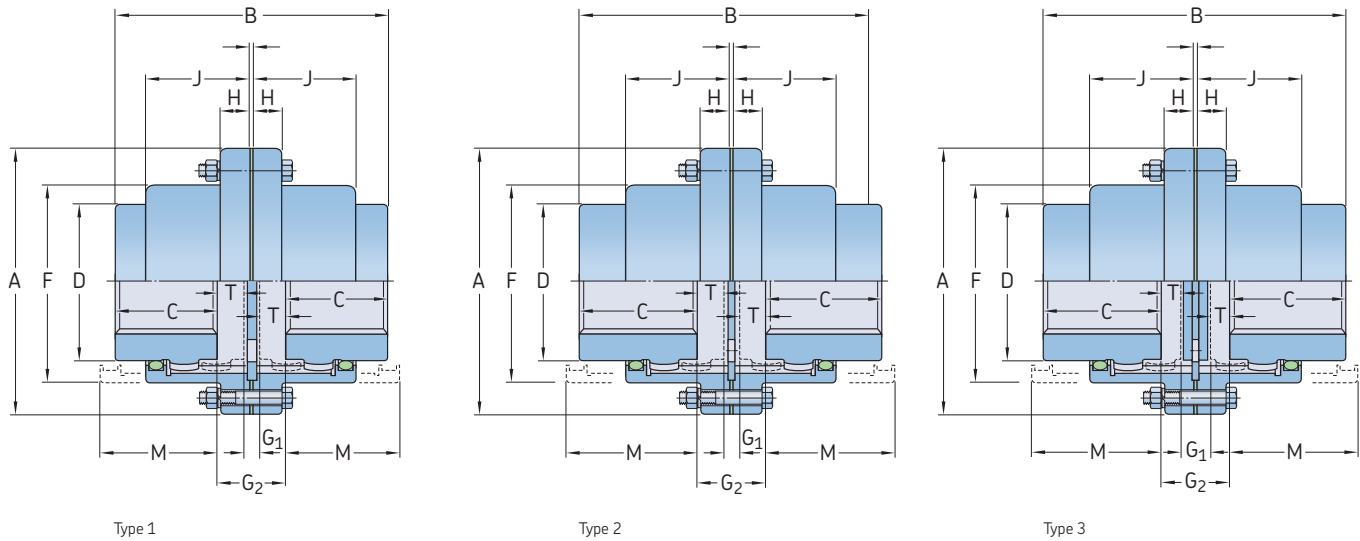

Size	Power per 100 r/min	Rated torque	Max speed	Bore diameter		Dimensions						Lubricant weight	Coupling weight without bore
				min.	max.	A	C	D	F	H	J		
–	kW	Nm	r/min	mm								kg	kg
10 GCSL	11,9	1 139	5 300	13	48	116	43	69	84	14	39	0,02	5
15 GCSL	24,6	2 350	4 300	19	60	152	49	86	105	19	48	0,04	9
20 GCSL	44,7	4 270	3 700	25	73	178	62	105	126	19	59	0,06	16
25 GCSL	78,3	7 474	3 300	32	92	213	77	131	155	21,8	72	0,11	29
30 GCSL	127	12 100	2 900	38	105	240	91	152	180	21,8	84	0,18	43
35 GCSL	194	18 500	2 600	51	124	279	106	178	211	28,4	98	0,27	68
40 GCSL	321	30 609	2 400	64	146	318	121	210	245	28,4	111	0,45	97
45 GCSL	440	42 000	2 100	76	165	346	135	235	274	28,4	123	0,51	136
50 GCSL	593	56 600	1 900	89	178	389	153	254	306	38,1	141	0,91	190
55 GCSL	775	74 030	1 800	102	197	425	168	279	334	38,1	158	1,13	249
60 GCSL	947	90 400	1 600	114	222	457	188	305	366	25,4	169	1,19	306
70 GCSL	1420	135 000	1 400	127	254	527	221	343	425	28,4	196	2,18	485

Size	Type 1						Type 2						Type 3					
	B max.	M ¹⁾	T max. Half	Total	G ₁ gap	G ₂ gap	B max.	M ¹⁾	T max. Half	Total	G ₁ gap	G ₂ gap	B max.	M ¹⁾	T max. Half	Total	G ₁ gap	G ₂ gap
–	mm						mm						mm					
10 GCSL	96	54	13	26	8	10	126	58	16	32	8	40	96	54	2	4	6	10
15 GCSL	127	60	10	20	8	29	152	69	23	46	8	54	127	60	7,5	15	14	29
20 GCSL	151	77	9	18	8	27	186	84	27	54	8	62	151	77	10	20	7	27
25 GCSL	188	93	12	24	9	34	231	102	34	68	9	78	188	93	6	12	21	34
30 GCSL	227	108	18	36	9	45	263	118	36	72	9	81	227	108	11,5	23	22	45
35 GCSL	274	124	25	50	11	61	313	135	45	90	11	102	274	124	14	28	33	61
40 GCSL	320	138	32	64	15	79	364	155	54	108	15	121	320	138	16	32	47	79
45 GCSL	355	154	35	70	16	86	406	163	60	120	16	136	355	154	19	38	47	86
50 GCSL	408	175	42	82	18	102	460	189	68	136	18	153	408	175	20,5	41	61	102
55 GCSL	470	191	58	116	18	134	510	221	78	156	18	174	470	191	21	42	92	134
60 GCSL	504	212	53	127	21	127	563	227	83	166	21	187	504	212	24,5	49	78	127
70 GCSL	592	245	62	149	26	150	669	235	99	198	26	223	592	245	27	54	96	150

¹⁾ Minimum clearance required for aligning coupling.

Larger sizes available: contact SKF for details.

Double engagement slide couplings are designed for horizontal close coupled applications and are designed to accommodate thermal expansion of the shaft and large mechanical vibratory screens.

These couplings are available with 3 different ranges of axial capabilities.

Single engagement

Slide

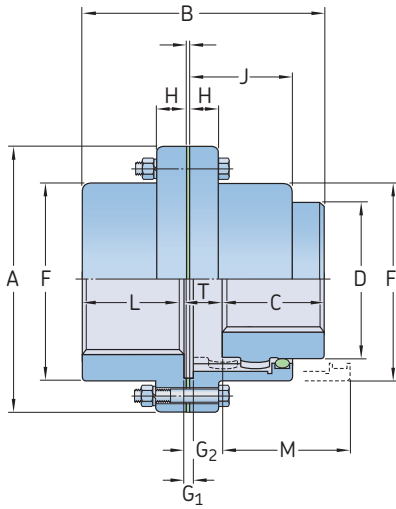

Type 1

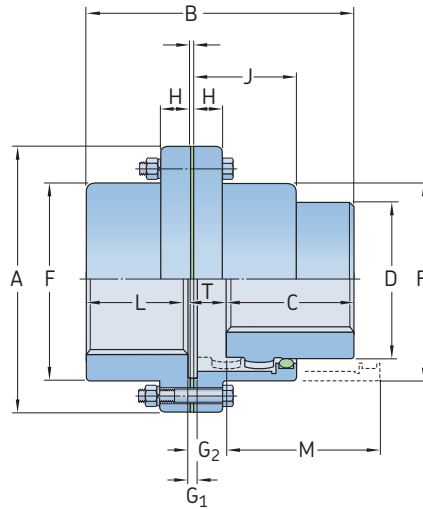

Type 2

Size	Power per 100 r/min	Rated torque	Max speed	Bore diameter			Dimensions							Lubricant weight	Coupling weight without bore
				max. (flex hub)	max. (se hub)	min.	A	C	D	F	H	J	L		
–	kW	Nm	r/min	mm										kg	kg
10 GCSL	11,9	1 139	5 300	48	60	13	116	43	69	84	14	39	40	0,01	5
15 GCSL	24,6	2 350	4 300	60	75	19	152	49	86	105	19	48	46	0,02	9
20 GCSL	44,7	4 270	3 700	73	92	25	178	62	105	126	19	59	58	0,04	16
25 GCSL	78,3	7 474	3 300	92	111	32	213	77	131	155	21,8	72	74	0,06	29
30 GCSL	127	12 100	2 900	105	130	38	240	91	152	180	21,8	84	88	0,11	43
35 GCSL	194	18 500	2 600	124	149	51	279	106	178	211	28,4	98	102	0,18	68
40 GCSL	321	30 609	2 400	146	171	64	318	121	210	245	28,4	111	115	0,27	97
45 GCSL	440	42 000	2 100	165	194	76	346	135	235	274	28,4	123	131	0,34	136
50 GCSL	593	56 600	1 900	178	222	89	389	153	254	306	38,1	141	147	0,54	195
55 GCSL	775	74 030	1 800	197	248	102	425	168	279	334	38,1	158	173	0,73	263
60 GCSL	947	90 400	1 600	222	267	114	457	188	305	366	25,4	169	186	0,96	324
70 GCSL	1 420	135 000	1 400	254	305	127	527	221	343	425	28,4	196	220	1,36	510

Size	Type 1					Type 2				
	B max.	M ¹⁾	T max.	G ₁ gap	G ₂ gap	B max.	M ¹⁾	T max.	G ₁ gap	G ₂ gap
–	mm					mm				
10 GCSL	90	54	3,6	4	8	105	58	18,5	4	23
15 GCSL	112	60	12,7	4	17	125	69	25,4	4	30
20 GCSL	136	77	11,7	4	16	154	84	29,5	4	34
25 GCSL	170	93	14,5	5	19	192	102	36,3	5	41
30 GCSL	204	108	20,1	5	25	222	118	38,1	5	43
35 GCSL	241	124	27,2	6	33	262	135	47,8	6	53
40 GCSL	279	138	36,3	7	43	300	155	57,4	7	65
45 GCSL	315	154	38,9	8	47	338	163	64	8	72
50 GCSL	356	175	47	9	56	382	189	72,6	9	81
55 GCSL	412,5	191	63	9	72	433	221	83,1	9	92
60 GCSL	445	212	59,7	10	70	475	227	89,4	10	100
70 GCSL	524	245	70,4	13	83	560	235	106,7	13	119

¹⁾ Minimum clearance required for aligning coupling.

Larger sizes available: contact SKF for details.
These couplings are available with 3 different ranges of axial capabilities.

Rigid flanged sleeve

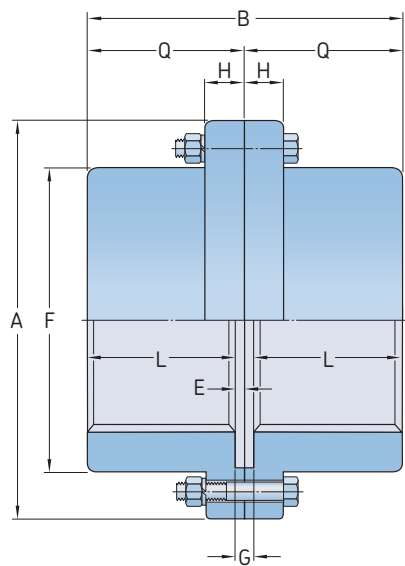

Size	Power per 100 r/min	Rated torque	Max speed	Bore diameter		Dimensions							Gap	Coupling weight without bore
				min.	max.	A	B	E	F	H	L	Q		
–	kW	Nm	r/min	mm									mm	kg
10 GCR	11,9	1 139	8 000	13	60	116	84,5	2,5	84	14	40	39	5	5
15 GCR	24,6	2 350	6 500	19	75	152	97,5	2,5	105	19	46	48	5	9
20 GCR	44,7	4 270	5 600	25	92	178	122	2,5	126	19	58,5	59	5	16
25 GCR	78,3	7 474	5 000	32	111	213	152,5	2,5	155	21,8	73,5	72	5	28
30 GCR	127	12 100	4 400	38	130	240	181	2,5	180	21,8	88	84	5	43
35 GCR	194	18 500	3 900	51	149	279	209	2,5	211	28,4	102	98	5	68
40 GCR	321	30 609	3 600	64	171	318	239	4,1	245	28,4	115	111	8	102
45 GCR	440	42 000	3 200	76	194	346	269	4,1	274	28,4	130,5	123	8	140
50 GCR	593	56 600	2 900	89	222	389	305	5,1	306	38,1	147,5	141	10	205
55 GCR	775	74 030	2 650	102	248	425	355,5	5,1	334	38,1	172,5	158	10	280
60 GCR	947	90 400	2 450	114	267	457	386	6,6	366	25,4	186,5	169	13	335
70 GCR	1 420	135 000	2 150	127	305	527	457	8,4	425	28,4	220	196	17	536
80 GCR	1 780	170 000	1 750	102	343	591	514	8	572	31,5	249	243	16	703
90 GCR	2 360	226 000	1 550	114	381	660	568	8	641	38	276	265	16	984
100 GCR	3 250	310 000	1 450	127	406	711	629	9,7	699	44,2	305	294	19	1 210
110 GCR	4 320	413 000	1 330	140	445	775	686	9,7	749	50,8	333	322	19	1 610
120 GCR	5 810	555 000	1 200	152	495	838	724	9,7	826	53,8	353	341	19	2 114

Rigid flanged sleeve couplings are designed for horizontal, close coupled applications. These are excellent high torque couplings to use where there is no need to accommodate misalignment.

Floating shaft gear couplings

The SKF floating shaft coupling consists of two standard single engagement couplings, two gap discs and a connector shaft.

A floating shaft can eliminate the requirement for additional bearing supports along the spanning shaft because the shaft is supported at the ends by connected equipment through the single engagement couplings.

Flex hubs on floating shafts

Assembly of the flex hubs on the floating shaft allows for easier replacement in case of coupling wear and allows the rigid hubs with their larger bore capacities to be used on the connected equipment shafts. This often allows for smaller coupling sizes in the design. See drawings on **page 33**.

Rigid hubs on floating shaft

When the rigid hubs are on the floating shaft, shorter shaft spans can be used since no cover drawback is required. Since the flex hubs are on the outboard side, the points of articulation are further apart, thus allowing for greater offset misalignment. See drawings on **page 33**.

Table 4

Floating shaft data

Size	Assembly rated torque	SB diameter	SD diameter	Max DBSE for r/min						
				1 750	1 430	1 170	870	720	580	< 540
–	Nm	mm	mm	mm						
10	493 1 139	38 47,5	40 51	1 371 1 549	1 524 1 727	1 676 1 905	1 955 2 209	2 159 2 438	2 387 2 717	2 463 2 794
15	1 169 2 350	51 60,3	54 76	1 600 1 752	1 778 1 930	1 955 2 133	2 286 2 463	2 514 2 717	2 794 3 022	2 870 3 124
20	2 282 4 270	63,5 73	66,5 95	1 778 1 905	1 981 2 108	2 184 2 336	2 540 2 717	2 794 2 971	3 098 3 327	3 200 3 429
25	4 463 7 474	79,5 92	82,5 95	1 981 2 133	2 209 2 362	2 438 2 616	2 819 3 022	3 098 3 237	3 454 3 708	3 556 3 835
30	8 508 12 100	98,5 105	101,5 127	2 209 2 260	2 438 2 514	2 692 2 794	3 124 3 225	3 454 3 556	3 835 3 962	3 962 4 064
35	13 333 18 500	114 124	120,5 146	2 413 2 463	2 667 2 717	2 946 3 022	3 403 3 505	3 759 3 860	4 191 4 292	4 292 4 419
40	24 327 30 609	139,5 146	146 165	2 641 2 692	2 921 2 997	3 251 3 302	3 759 3 835	4 140 4 216	4 597 4 699	4 749 4 851
45	31 581 42 000	152,5 171,5	165 203	2 819 3 124	3 124 3 454	3 454 3 810	3 987 4 445	4 394 4 876	4 902 5 435	5 029 5 588
50	37 886 56 600	162 187,5	165 203	2 819 3 124	3 124 3 454	3 454 3 810	3 987 4 445	4 394 4 876	4 902 5 435	5 029 5 588
55	37 886 74 030	162 200	165 203	2 819 3 124	3 124 3 454	3 454 3 810	3 987 4 445	4 394 4 876	4 902 5 435	5 029 5 588
60	71 410 90 404	200 216	203 217,5	3 124 3 225	3 454 3 581	3 810 3 962	4 445 4 597	4 876 5 054	5 435 5 613	5 588 5 791
70	71 410 13 5000	200 241,5	203 243	3 124 3 403	3 454 3 784	3 810 4 191	4 445 4 851	4 876 5 334	5 435 5 943	5 588 6 121

Assembly torque ratings are limited by the coupling size, shaft end diameter or both. Interpolate for intermediate speeds. The maximum DBSE is based on 70% of the critical speed.

Diagram 1

Balancing requirements

Operating speed – r/min

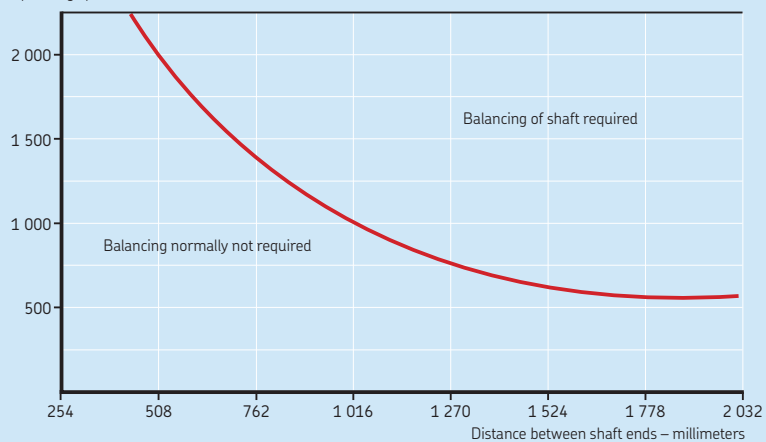

Solid floating shaft selection

Single engagement type GCSE and GCSEV couplings are used with floating shafts in either horizontal or vertical applications. For vertical applications, select a type V coupling for the lower assembly. Select floating shaft couplings as follows:

- 1** Use the standard or formula selection methods and see product tables on **page 32** and **33** to select the coupling. Record the system torque from the standard method or the selection torque from formula method.
- 2** Select the shaft diameter from product tables on **pages 32** and **33** that has an assembly torque rating equal to or greater than the system or the selection torque determined in the coupling selection.
- 3** Check the maximum “DBSE” for the shaft diameter you selected and the running speed for the shaft length required from product tables on **page 32** and **33**. Refer to the graph in **diagram 1** on **page 30** to determine if the shaft requires balancing.
- 4** If the application shaft length exceeds the maximum “DBSE” listed, you must select the next larger shaft diameter or the next larger size coupling.

Single engagement
Vertical and floating shaft

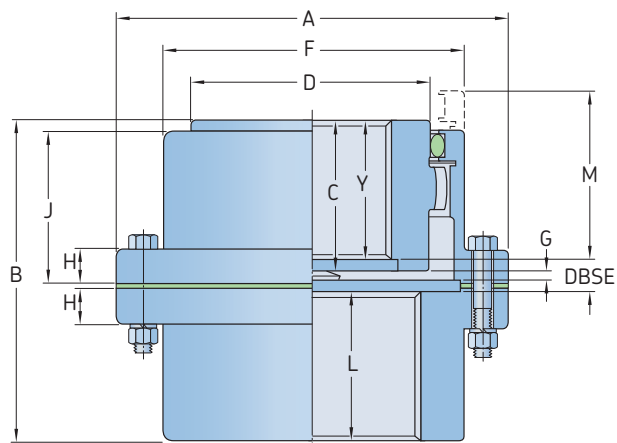
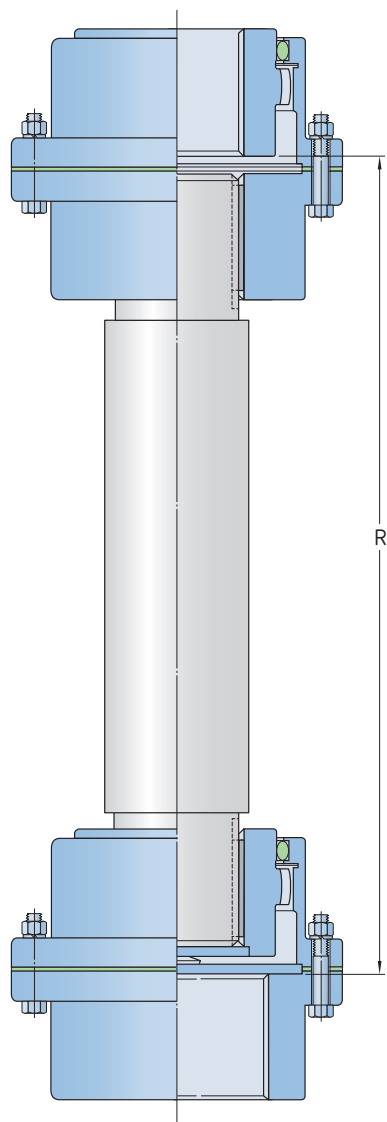

Size	Power per 100 r/min	Rated torque	Max speed	Bore diameter			Dimensions															Gap	Lubricant weight	Coupling weight without bore
				max. (flex hub)	max. (se hub)	min.	A	B	C	D	F	H	J	L	M	R	Y	DBSE	G					
–	kW	Nm	r/min	mm			mm															mm	kg	kg
10 GCV	11,9	1 139	7 000	48	60	13	116	87	43	69	84	14	39	40	51	132	32,5	14,7	4	0,02	4,5			
15 GCV	24,6	2 350	5 500	60	75	19	152	99	49	86	105	19	48	46	61	152	38,6	14,7	4	0,04	9,1			
20 GCV	44,7	4 270	4 600	73	92	25	178	124	62	105	126	19	59	58	77	183	51,3	14,7	4	0,07	15,9			
25 GCV	78,3	7 474	4 000	92	111	32	213	156	77	131	155	21,8	72	74	92	218	65,3	16,3	5	0,12	27,2			
30 GCV	127	12 100	3 600	105	130	38	240	184	91	152	180	21,8	84	88	107	248	79,8	16,3	5	0,18	43,1			
35 GCV	194	18 500	3 100	124	149	51	279	213,5	106	178	211	28,4	98	102	130	298	94,0	18,0	6	0,27	61,2			
40 GCV	321	30 609	2 800	146	171	64	318	243	121	210	245	28,4	111	115	145	340	105,9	22,0	7	0,47	99,8			
45 GCV	440	42 000	2 600	165	194	76	346	274	135	235	274	28,4	123	131	166	388	116,3	26,7	8	0,57	136,1			
50 GCV	593	56 600	2 400	178	222	89	389	309	153	254	306	38,1	141	147	183	424	134,6	27,7	9	0,91	195,0			
55 GCV	775	74 030	2 200	197	248	102	425	350	168	279	334	38,1	158	173	204	464	149,6	27,7	9	1,13	263,1			
60 GCV	947	90 400	2 100	222	267	114	457	384	188	305	366	25,4	169	186	229	522	168,1	30,9	10	1,70	324,3			
70 GCV	1 420	135 000	1 800	254	305	127	527	454	221	343	425	28,4	196	220	267	615	194,8	39,1	13	2,27	508			

Single engagement

Floating shaft

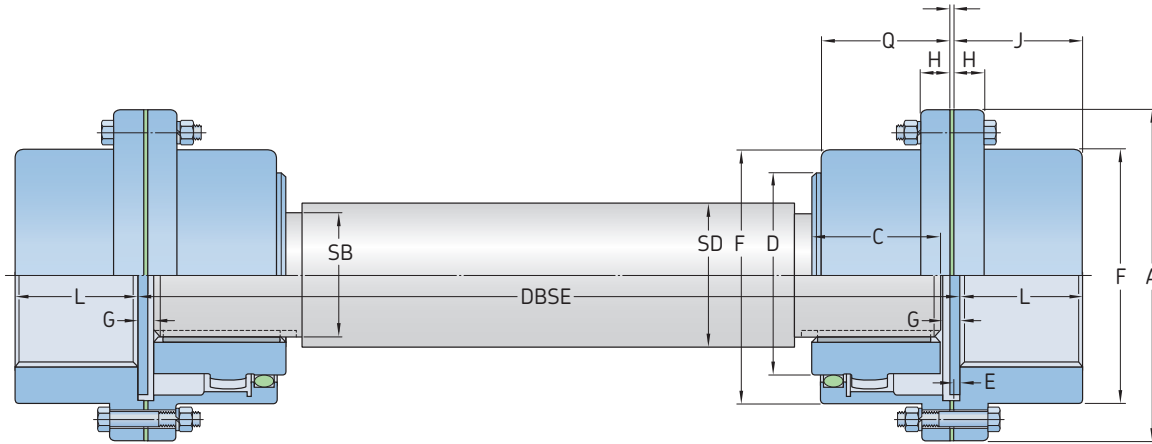

Flex hubs on floating shaft

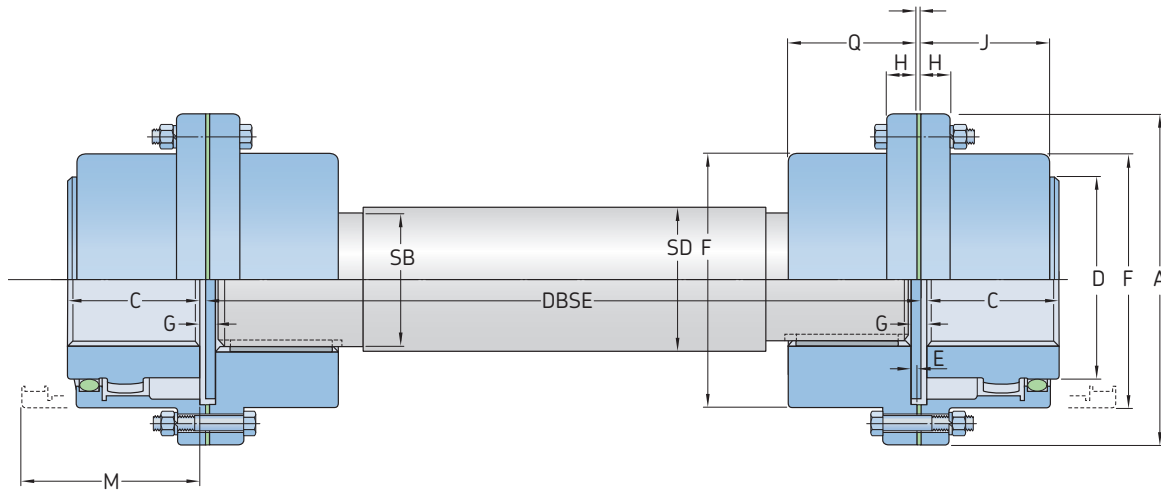

Rigid hubs on floating shaft

Size	DBSE		Bore diameter			Dimensions									Gap	Min lubricant weight	Coupling weight without bore
	min. (flex hub)	max. (rigid hub)	max. (flex hub)	max. (rigid hub)	min.	A	C	D	F	H	J	L	M				
	mm														kg	kg	
10 GCFS	133	92	48	60	13	116	43	69	84	14	39	40	51	4	0,02	4,5	
15 GCFS	159	105	60	75	19	152	49	86	105	19	48	46	61	4	0,04	9,1	
20 GCFS	197	129	73	92	25	178	62	105	126	19	59	58	77	4	0,07	15,9	
25 GCFS	241	162	92	111	32	213	77	131	155	21,8	72	74	92	5	0,12	27,2	
30 GCFS	279	189	105	130	38	240	91	152	180	21,8	84	88	107	5	0,18	43,1	
35 GCFS	324	219	124	149	51	279	106	178	211	28,4	98	102	130	6	0,27	61,2	
40 GCFS	419	248	146	171	64	318	121	210	245	28,4	111	115	145	7	0,47	99,8	
45 GCFS	508	281	165	194	76	346	135	235	274	28,4	123	131	166	8	0,57	136,1	
50 GCFS	533	316	178	222	89	389	153	254	306	38,1	141	147	183	9	0,91	195,0	
55 GCFS	572	367	197	248	102	425	168	279	334	38,1	158	173	204	9	1,13	263,1	
60 GCFS	597	397	222	267	114	457	188	305	366	25,4	169	186	229	10	1,70	324,3	
70 GCFS	673	470	254	305	127	527	221	343	425	28,4	196	220	267	13	2,27	508	

SKF Flex Couplings

SKF Flex Couplings are designed to accommodate misalignment and shock loads and dampen vibration levels. These easy to install, maintenance-free couplings are available with either a machined-to-size or tapered bore.

Couplings with a tapered bore can be Face (F) mounted or Hub (H) mounted. The more versatile Reversible (R) design can be either face or hub mounted depending on the application. These couplings are also available with a tapered bushing.

SKF Flex Couplings consist of 2 flanges and 1 tyre. The flanges are phosphate coated for improved corrosion resistance. The addition of a standard sized spacer flange can be used to accommodate applications where it is advantageous to move either shaft axially without disturbing either driving or driven machines.

SKF Flex tyres are available in natural rubber compounds for applications ranging from -50 to +50 °C. Chloroprene rubber compounds should be used in applications where exposure to greases and oils are likely. These compounds can accommodate temperatures ranging from -15 to +70 °C. The chloroprene tyres should be used where fire-resistance and anti-static (F.R.A.S.) properties are required.

Selection

1 Service factor

Determine the required service factor from **tables 7 and 8 on pages 60 and 61.**

2 Design power

Multiply the normal running power by the service factor. This gives the design power for coupling selection.

3 Coupling size

Using the data from **table 1 on page 35,** find the speed rating for a coupling that has a power that is greater than the design power. The required SKF Flex coupling is listed at the head of the column.

4 Bore size

Using product tables on **page 38 and 39,** check if the chosen flanges can accommodate both the driving and driven shafts.

Example

A SKF Flex coupling is required to transmit 30 kW from an electric motor running at 1 440 r/min to a centrifugal pump for 14 hours per day. The diameter of the motor shaft is 30 mm. The diameter of the pump shaft is 25 mm. A tapered bore is required.

1 Service factor

The appropriate service factor is 1. See **tables 7 and 8 on pages 60 and 61.**

2 Design power

Design power = $30 \times 1 = 30$ kW

3 Coupling size

By searching for 1 440 r/min in **table 1 on page 35,** the first power figure to exceed the required 30 kW in step (2) is 37,70 kW. The size of the coupling is 70.

4 Bore size

By referring to product tables on **page 38 and 39,** it can be seen that both shaft diameters fall within the bore range available. Please note that for this coupling the bore sizes for the Face and Hub design are different.

Engineering data

Power ratings

Maximum torque figures should be treated as short duration overload ratings occurring in circumstances such as direct-on-line starting.

For speeds not shown, calculate the nominal torque for the design application using the formula below and select a coupling based on the nominal torque ratings.

Nominal torque (Nm) =

$$\frac{\text{Design power (kW)} \times 9\,549}{\text{r/min}}$$

For additional information about SKF Flex Couplings, see **table 1 and 2.**

Table 1

Power ratings (kW)

Speed	Coupling size															
	40	50	60	70	80	90	100	110	120	140	160	180	200	220	250	
r/min	kW															
50	0,13	0,35	0,66	1,31	1,96	2,62	3,53	4,58	6,96	12,17	19,74	32,83	48,82	60,73	76,83	
100	0,25	0,69	1,33	2,62	3,93	5,24	7,07	9,16	13,93	24,35	39,48	65,65	97,64	121,47	153,66	
200	0,50	1,38	2,66	5,24	7,85	10,47	14,14	18,32	27,85	48,69	78,95	131,31	195,29	242,93	307,33	
300	0,75	2,07	3,99	7,85	11,78	15,71	21,20	27,49	41,78	73,04	118,43	196,96	292,93	364,40	460,99	
400	1,01	2,76	5,32	10,47	15,71	20,94	28,27	36,65	55,71	97,38	157,91	262,62	390,58	485,86	614,66	
500	1,26	3,46	6,65	13,09	19,63	26,18	35,34	45,81	69,63	121,73	197,38	328,27	488,22	607,33	768,32	
600	1,51	4,15	7,98	15,71	23,56	31,41	42,41	54,97	83,56	146,07	236,86	393,93	585,86	728,80	921,99	
700	1,76	4,84	9,31	18,32	27,49	36,65	49,48	64,14	97,49	170,42	276,34	459,58	683,51	850,26	1 075,65	
720	1,81	4,98	9,57	18,85	28,27	37,70	50,89	65,97	100,27	175,29	284,23	472,71	703,04	874,55	1 106,39	
800	2,01	5,53	10,64	20,94	31,41	41,88	56,54	73,30	111,41	194,76	315,81	525,24	781,15	971,73	1 229,32	
900	2,26	6,22	11,97	23,56	35,34	47,12	63,61	82,46	125,34	219,11	355,29	590,89	878,80	1 093,19	1 382,98	
960	2,41	6,63	12,77	25,13	37,70	50,26	67,85	87,96	133,70	233,72	378,97	630,28	937,38	1 166,07	1 475,18	
1 000	2,51	6,91	13,30	26,18	39,27	52,36	70,68	91,62	139,27	243,46	394,76	656,54	976,44	1 214,66	1 536,65	
1 200	3,02	8,29	15,96	31,41	47,12	62,83	84,82	109,95	167,12	292,15	473,72	787,85	1 171,73	–	–	
1 400	3,52	9,68	18,62	36,65	54,97	73,30	98,95	128,27	194,97	340,84	552,67	919,16	–	–	–	
1 440	3,62	9,95	19,15	37,70	56,54	75,39	101,78	131,94	200,54	350,58	568,46	945,42	–	–	–	
1 600	4,02	11,06	21,28	41,88	62,83	83,77	113,09	146,60	222,83	389,53	631,62	–	–	–	–	
1 800	4,52	12,44	23,94	47,12	70,68	94,24	127,23	164,92	250,68	438,22	–	–	–	–	–	
2 000	5,03	13,82	26,60	52,36	78,53	104,71	141,36	183,25	278,53	–	–	–	–	–	–	
2 200	5,53	15,20	29,26	57,59	86,39	115,18	155,50	201,57	–	–	–	–	–	–	–	
2 400	6,03	16,59	31,92	62,83	94,24	125,65	169,63	–	–	–	–	–	–	–	–	
2 600	6,53	17,97	34,58	68,06	102,09	136,13	183,77	–	–	–	–	–	–	–	–	
2 800	7,04	19,35	37,24	73,30	109,95	146,60	–	–	–	–	–	–	–	–	–	
2 880	7,24	19,90	38,30	75,39	113,09	150,79	–	–	–	–	–	–	–	–	–	
3 000	7,54	20,73	39,90	78,53	117,80	157,07	–	–	–	–	–	–	–	–	–	
3 600	9,05	24,88	47,87	94,24	–	–	–	–	–	–	–	–	–	–	–	
Nominal torque (Nm)	24	66	127	250	375	500	675	875	1 330	2 325	3 770	6 270	9 325	11 600	14 675	
Max torque (Nm)	64	160	318	487	759	1 096	1 517	2 137	3 547	5 642	9 339	16 455	23 508	33 125	42 740	

Table 2

Assembled coupling characteristics

Coupling size	Maximum speed	Mass	Inertia	Torsional stiffness	Misalignment			Nominal torque	Max torque	Screw size	Clamping screw torque
					Angular	Parallel	Axial				
–	r/min	kg	kg/m ²	Nm/°	°	mm		Nm	Nm	–	Nm
40	4 500	0,1	0,00074	5	4	1,1	1,3	24	64	M6	15
50	4 500	0,3	0,00115	13	4	1,3	1,7	66	160	M6	15
60	4 000	0,5	0,0052	26	4	1,6	2,0	127	318	M6	15
70	3 600	0,7	0,009	41	4	1,9	2,3	250	487	M8	24
80	3 100	1,0	0,017	63	4	2,1	2,6	375	759	M8	24
90	3 000	1,1	0,031	91	4	2,4	3,0	500	1 096	M10	40
100	2 600	1,1	0,054	126	4	2,6	3,3	675	1 517	M10	40
110	2 300	1,4	0,078	178	4	2,9	3,7	875	2 137	M10	40
120	2 050	2,3	0,13	296	4	3,2	4,0	1 330	3 547	M12	50
140	1 800	2,6	0,255	470	4	3,7	4,6	2 325	5 642	M12	55
160	1 600	3,4	0,380	778	4	4,2	5,3	3 770	9 339	M16	80
180	1 500	7,7	0,847	1 371	4	4,8	6,0	6 270	16 455	M16	105
200	1 300	8,0	1,281	1 959	4	5,3	6,6	9 325	23 508	M16	120
220	1 100	10,0	2,104	2 760	4	5,8	7,3	11 600	33 125	M20	165
250	1 000	15,0	3,505	3 562	4	6,6	8,2	14 675	42 740	M20	165

Order data

A complete SKF Flex coupling consists of:
2 flanges and 1 tyre.

For additional information about ordering
a coupling see **table 3**.

Table 3

Order data										
Coupling type	Flanges	Qty	Element	Qty	Spacer shaft	Qty	Spacer flange and shaft ¹⁾	Qty	Ring kit	Qty
RSB both sides	PHE F70RSBFLG	2	PHE F70NRTYRE	1	–	–	–	–	–	–
	PHE F70FRITYRE	–	–	–	–	–	–	–	–	–
RSB/F combination	PHE F70RSBFLG	1	PHE F70NRTYRE or	1	–	–	–	–	–	–
	PHE F70HTBFLG	1	PHE F70FRITYRE	–	PHF TB2012X...MM	1	PHE SM25-...DBSE	1	PHF 2517X...MM	1
RSB/H combination	PHE F70RSBFLG	1	PHE F70NRTYRE or	1	–	–	–	–	–	–
	PHE F70HTBFLG	1	PHE F70FRITYRE	–	PHF TB1610X...MM	1	PHE SM25-...DBSE	1	PHF 2517X...MM	1
F/F Combination	PHE F70FTBFLG	2	PHE F70NRTYRE or	1	PHF TB2012X...MM	1	PHE SM25-...DBSE	1	PHF 2517X...MM	1
	PHE F70HTBFLG	2	PHE F70FRITYRE	–	PHF TB2012X...MM	1	–	–	–	–
H/H Combination	PHE F70HTBFLG	1	PHE F70NRTYRE or	1	PHF TB1610X...MM	1	PHE SM25-...DBSE	1	PHF 2517X...MM	1
	PHE F70HTBFLG	1	PHE F70FRITYRE	–	PHF TB1610X...MM	1	–	–	–	–
F/H Combination	PHE F70FTBFLG	1	PHE F70NRTYRE or	1	PHF TB1610X...MM	1	PHE SM25-...DBSE	1	PHF 2517X...MM	1
	PHE F70HTBFLG	1	PHE F70FRITYRE	–	PHF TB2012X...MM	1	–	–	–	–
Reversible	PHE F70RTBFLG	2	PHE 50GCCOVER	2	PHF TB1610X...MM	2	–	–	–	–

¹⁾ To complete designation add distance between shaft ends, PHE SM25-100DBSE.

An SKF Flex coupling consists of 2 flanges and 1 tyre. An SKF Flex Spacer Coupling consists of 2 flanges, 1 tyre and 1 spacer (spacer part number consists of spacer shaft and rigid flange).

Installation

1 All metal components should be cleaned. Be sure to remove the protective coating on the flange bores. The tapered bushings should be placed into the flanges and the screws lightly tightened.

2 If internal clamping rings are being used (size 40–60), position them onto the shaft (1). Place the flanges next to the clamping ring on each shaft and position them so that dimension M is obtained between the flange faces (→ table 4).

Where tapered bushings are used, see separate fitting instructions supplied with the taper bushes.

Flanges with external clamping rings (sizes 70–250) should have the clamping rings fitted when installing, engaging only two or three of the threads of each screw at this time. These flanges should be positioned so that M is obtained by measuring the gap between the flange faces.

3 If shaft end float is to occur, locate the shafts at mid-position of end float when checking dimension M. Note that shaft ends may project beyond the faces of the flanges if required. In these cases, allow sufficient space between shaft ends for end float and misalignment.

4 Parallel alignment should be checked by placing a straight edge across the flanges at various points around the circumference (3). Angular alignment is checked by measuring the gap between the flanges at several positions around the circumference. Align the coupling as accurately as possible, particularly on high-speed applications.

5 Spread the tyre side walls apart and fit over the coupling flanges, making sure that the tyre beads seat properly on the flanges and clamping rings. To make sure that the tyre sits properly in position, it may be necessary to strike the outside diameter of the tyre with a small mallet (4). When the tyre is correctly positioned there, should be a gap between the ends of the tyre as shown in table 5 (5).

6 Tighten clamping ring screws (6) alternately and evenly (half turn at a time), working round each flange until the required screw torque is achieved (→ table 4).

Table 4

SKF Flex coupling assembly data			
Coupling size	M size	Screw size	Clamping screw torque
–	mm	–	Nm
F40 ¹⁾	22	M6	15
F50 ¹⁾	25	M6	15
F60 ¹⁾	33	M6	15
F70	23	M8	24
F80	25	M8	24
F90	27	M10	40
F100	27	M10	40
F110	25	M10	40
F120	29	M12	50
F140	32	M12	55
F160	30	M16	80
F180	46	M16	105
F200	48	M16	120
F220	55	M20	165
F250	59	M20	165

¹⁾ Hexagon socket caphead clamping screws on these sizes

Table 5

SKF Flex coupling tyre gap	
Coupling size	Tyre gap
–	mm
F40 to F60	2
F70 to F120	3
F140 and F160	5
F180 to F250	6

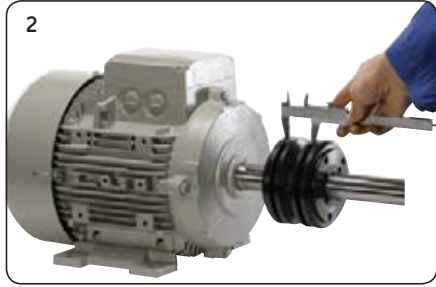
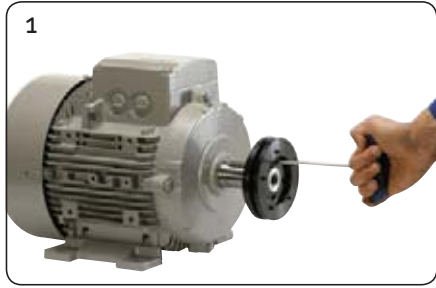
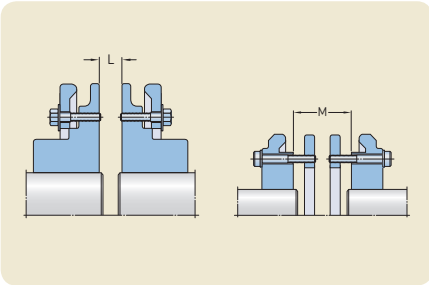

SKF Flex flanges types B, F and H

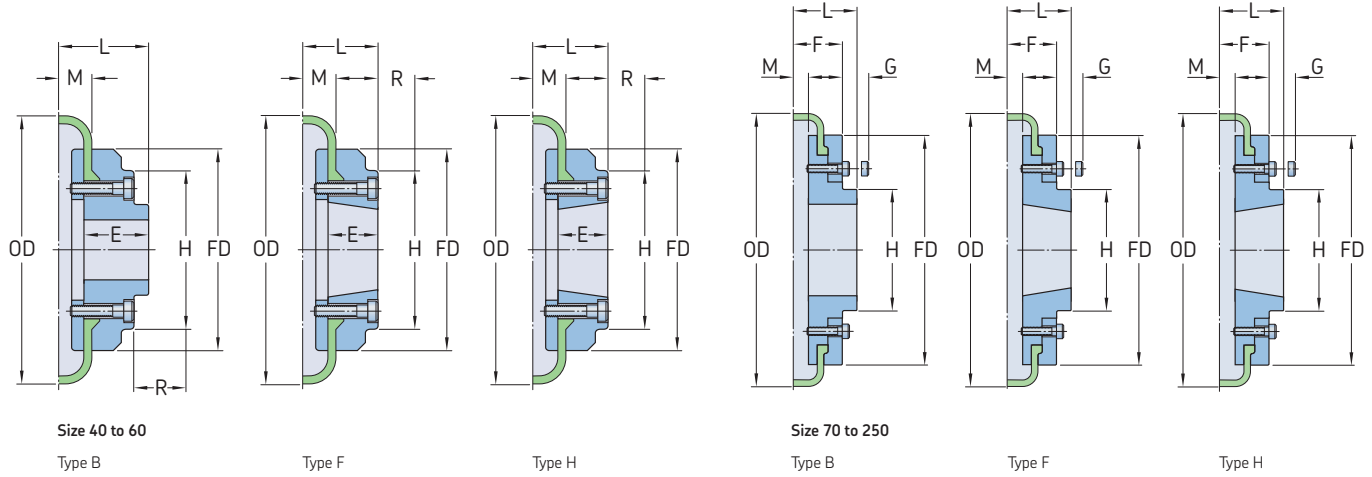

Size	Type	Bush No.	Dimensions		Types F & H		Type B		Key screw	OD	FD	H	F	R ¹⁾	G ²⁾	M	Mass	Inertia	Designation	Tyre designation	
			Bore Min.	Max.	L	E	L	E												Natural	F.R.A.S
mm	-	-	mm													kg	kg/m ²	-			
Size 40 to 60																					
40	B	-	-	30	-	-	33,0	22	M5	104	82	-	-	29	-	11,0	0,80	0,00074	PHE F40RSBFLG	PHE F40NRTYRE	PHE F40FRTYRE
40	F	1008	9	25	33,0	22	-	-	-	104	82	-	-	29	-	11,0	0,80	0,00074	PHE F40FTBFLG	PHE F40NRTYRE	PHE F40FRTYRE
40	H	1008	9	25	33,0	22	-	-	-	104	82	-	-	29	-	11,0	0,80	0,00074	PHE F40HTBFLG	PHE F40NRTYRE	PHE F40FRTYRE
50	B	-	-	38	-	-	45,0	32	M5	133	100	79	-	38	-	12,5	1,20	0,00115	PHE F50RSBFLG	PHE F50NRTYRE	PHE F50FRTYRE
50	F	1210	11	32	37,5	25	-	-	-	133	100	79	-	38	-	12,5	1,20	0,00115	PHE F50FTBFLG	PHE F50NRTYRE	PHE F50FRTYRE
50	H	1210	11	32	37,5	25	-	-	-	133	100	79	-	38	-	12,5	1,20	0,00115	PHE F50HTBFLG	PHE F50NRTYRE	PHE F50FRTYRE
60	B	-	-	45	-	-	55,0	38	M6	165	125	70	-	38	-	16,5	2,00	0,0052	PHE F60RSBFLG	PHE F60NRTYRE	PHE F60FRTYRE
60	F	1610	14	42	41,5	25	-	-	-	165	125	103	-	38	-	16,5	2,00	0,0052	PHE F60FTBFLG	PHE F60NRTYRE	PHE F60FRTYRE
60	H	1610	14	42	41,5	25	-	-	-	165	125	103	-	38	-	16,5	2,00	0,0052	PHE F60HTBFLG	PHE F60NRTYRE	PHE F60FRTYRE
Size 70 to 250																					
70	B	-	-	60	-	-	47,0	35	M10	187	142	80	50	-	13	11,5	3,10	0,009	PHE F70RSBFLG	PHE F70NRTYRE	PHE F70FRTYRE
70	F	2012	14	50	43,5	32	-	-	-	187	142	80	50	42	13	11,5	3,10	0,009	PHE F70FTBFLG	PHE F70NRTYRE	PHE F70FRTYRE
70	H	1610	14	42	36,5	25	-	-	-	187	142	80	50	38	13	11,5	3,00	0,009	PHE F70HTBFLG	PHE F70NRTYRE	PHE F70FRTYRE
80	B	-	-	63	-	-	55,0	42	M10	211	165	98	54	-	16	12,5	4,90	0,018	PHE F80RSBFLG	PHE F80NRTYRE	PHE F80FRTYRE
80	F	2517	16	60	57,5	45	-	-	-	211	165	97	54	48	16	12,5	4,90	0,018	PHE F80FTBFLG	PHE F80NRTYRE	PHE F80FRTYRE
80	H	2012	14	50	44,5	32	-	-	-	211	165	98	54	32	16	12,5	4,60	0,017	PHE F80HTBFLG	PHE F80NRTYRE	PHE F80FRTYRE
90	B	-	-	75	-	-	62,5	49	M12	235	187	112	60	-	16	13,5	7,10	0,032	PHE F90RSBFLG	PHE F90NRTYRE	PHE F90FRTYRE
90	F	2517	16	60	58,5	45	-	-	-	235	187	108	60	48	16	13,5	7,00	0,031	PHE F90FTBFLG	PHE F90NRTYRE	PHE F90FRTYRE
90	H	2517	16	60	58,5	45	-	-	-	235	187	108	60	48	16	13,5	7,00	0,031	PHE F90HTBFLG	PHE F90NRTYRE	PHE F90FRTYRE
100	B	-	-	80	-	-	69,5	56	M12	254	214	125	62	-	16	13,5	9,90	0,055	PHE F100RSBFLG	PHE F100NRTYRE	PHE F100FRTYRE
100	F	3020	25	75	64,5	51	-	-	-	254	214	120	62	55	16	13,5	9,90	0,055	PHE F100FTBFLG	PHE F100NRTYRE	PHE F100FRTYRE
100	H	2517	16	60	58,5	45	-	-	-	254	214	113	62	48	16	13,5	9,40	0,054	PHE F100HTBFLG	PHE F100NRTYRE	PHE F100FRTYRE
110	B	-	-	90	-	-	75,5	63	M12	279	232	128	62	-	16	12,5	12,50	0,081	PHE F110RSBFLG	PHE F110NRTYRE	PHE F110FRTYRE
110	F	3020	25	75	63,5	51	-	-	-	279	232	134	62	55	16	12,5	11,70	0,078	PHE F110FTBFLG	PHE F110NRTYRE	PHE F110FRTYRE
110	H	3020	25	75	63,5	51	-	-	-	279	232	134	62	55	16	12,5	11,70	0,078	PHE F110HTBFLG	PHE F110NRTYRE	PHE F110FRTYRE
120	B	-	-	100	-	-	84,5	70	M16	314	262	143	67	-	16	14,5	16,90	0,137	PHE F120RSBFLG	PHE F120NRTYRE	PHE F120FRTYRE
120	F	3525	35	100	79,5	65	-	-	-	314	262	140	67	67	16	14,5	16,50	0,137	PHE F120FTBFLG	PHE F120NRTYRE	PHE F120FRTYRE
120	H	3020	25	75	65,5	51	-	-	-	314	262	140	67	55	16	14,5	15,90	0,130	PHE F120HTBFLG	PHE F120NRTYRE	PHE F120FRTYRE
140	B	-	-	125	-	-	110,5	94	M20	359	312,5	180	73	-	17	16,0	22,20	0,254	PHE F140RSBFLG	PHE F140NRTYRE	PHE F140FRTYRE
140	F	3525	35	100	81,0	65	-	-	-	359	312,5	180	73	67	17	16,0	22,30	0,255	PHE F140FTBFLG	PHE F140NRTYRE	PHE F140FRTYRE
140	H	3525	35	100	81,0	65	-	-	-	359	312,5	180	73	67	17	16,0	22,30	0,255	PHE F140HTBFLG	PHE F140NRTYRE	PHE F140FRTYRE
160	B	-	-	140	-	-	117,0	102	M20	402	348	197	78	-	19	15,0	35,80	0,469	PHE F160RSBFLG	PHE F160NRTYRE	PHE F160FRTYRE
160	F	4030	40	115	91,0	76	-	-	-	402	348	197	78	80	19	15,0	32,50	0,380	PHE F160FTBFLG	PHE F160NRTYRE	PHE F160FRTYRE
160	H	4030	40	115	91,0	76	-	-	-	402	348	197	78	80	19	15,0	32,50	0,380	PHE F160HTBFLG	PHE F160NRTYRE	PHE F160FRTYRE
180	B	-	-	150	-	-	137,0	114	M20	470	396	205	94	-	19	23,0	49,10	0,871	PHE F180RSBFLG	PHE F180NRTYRE	PHE F180FRTYRE
180	F	4535	55	125	112,0	89	-	-	-	470	396	205	94	89	19	23,0	42,20	0,847	PHE F180FTBFLG	PHE F180NRTYRE	PHE F180FRTYRE
180	H	4535	55	125	112,0	89	-	-	-	470	396	205	94	89	19	23,0	42,20	0,847	PHE F180HTBFLG	PHE F180NRTYRE	PHE F180FRTYRE
200	B	-	-	150	-	-	138,0	114	M20	508	432	205	103	-	19	24,0	58,20	1,301	PHE F200RSBFLG	PHE F200NRTYRE	PHE F200FRTYRE
200	F	4535	55	125	113,0	89	-	-	-	508	432	205	103	89	19	24,0	53,60	1,281	PHE F200FTBFLG	PHE F200NRTYRE	PHE F200FRTYRE
200	H	4535	55	125	113,0	89	-	-	-	508	432	205	103	89	19	24,0	53,60	1,281	PHE F200HTBFLG	PHE F200NRTYRE	PHE F200FRTYRE
220	B	-	-	160	-	-	154,5	127	M20	562	472	224	118	-	20	27,5	79,60	2,142	PHE F220RSBFLG	PHE F220NRTYRE	PHE F220FRTYRE
220	F	5040	70	125	129,5	102	-	-	-	562	472	224	118	92	20	27,5	72,00	2,104	PHE F220FTBFLG	PHE F220NRTYRE	PHE F220FRTYRE
220	H	5040	70	125	129,5	102	-	-	-	562	472	224	118	92	20	27,5	72,00	2,104	PHE F220HTBFLG	PHE F220NRTYRE	PHE F220FRTYRE
250	B	-	-	190	-	-	161,5	132	M20	628	532	254	125	-	25	29,5	104,00	3,505	PHE F250RSBFLG	PHE F250NRTYRE	PHE F250FRTYRE

¹⁾ Is the clearance required to allow tightening of the clamping screws and the tapered bushing. Use of a shortened wrench will reduce this dimension.

²⁾ The amount by which the clamping screws need to be withdrawn to release the tyre.

For coupling sizes 70, 80, 100 and 120 "F" flanges require a larger bushing than "H" flanges.

Mass and inertia figures are for a single flange with midrange bore and include clamping ring, screws, washers and half tyre.

SKF Flex flanges type R

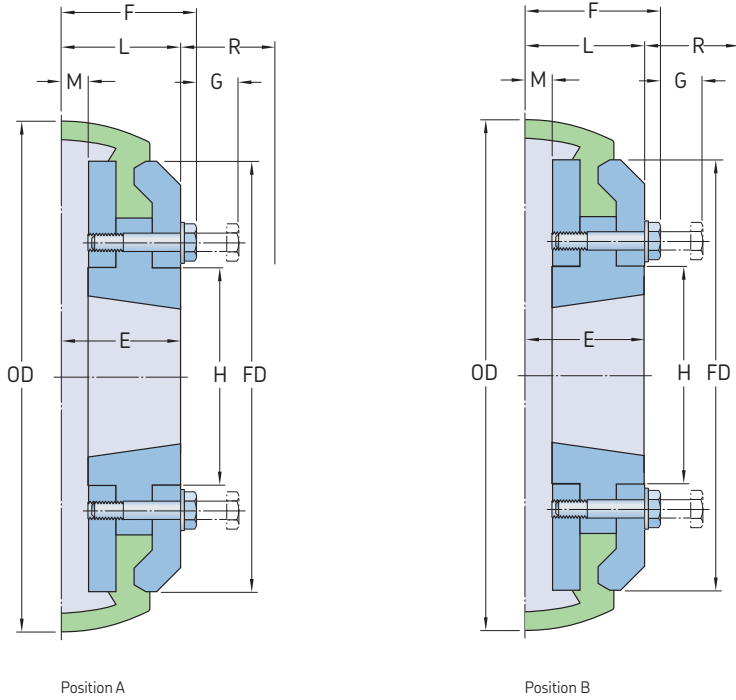

Size	Bush No.	Dimensions		L	E	R	Key screw	OD	FD	H	F	G ²⁾	M	Mass	Inertia	Designation
		Bore Min.	Max.													
-	-	mm												kg	kg/m ²	-
70	1610	14	42	37	25	42	M8	187	142	80	44,25	13	11,5	3	0,009	PHE F70RTBFLG
80	2012	14	50	45,5	32	48	M8	211	165	98	52,75	16	12,5	4,6	0,017	PHE F80RTBFLG
90	2517	16	60	58,5	45	48	M10	235	187	112	67,86	16	13,5	7	0,031	PHE F90RTBFLG
100	2517	16	60	59,5	45	55	M10	254	214	125	68,86	16	13,5	9,4	0,054	PHE F100RTBFLG
110	3020	25	75	64,5	51	55	M10	279	232	134	73,68	16	12,5	11,7	0,078	PHE F110RTBFLG
120	3020	25	75	66,5	51	67	M12	314	262	140	77,18	16	14,5	15,9	0,13	PHE F120RTBFLG

¹⁾ Is the clearance required to allow tightening of the clamping screws and the tapered bushing. Use of a shortened wrench will reduce this dimension.

²⁾ The distance that the clamping screws need to be withdrawn to release the tyre.

For coupling sizes 70, 80, 100 and 120 "F" flanges require a larger bushing than "H" flanges.

Mass and inertia figures are for a single flange with midrange bore and include clamping rings, screws, washers and a half tyre.

SKF Flex Spacer Coupling

The SKF Flex coupling spacer is used to join two shaft ends that cannot be positioned close enough to just use a coupling alone.

The spacer also allows removal of a shaft without the need to move either the driving or the driven machine. For example, this allows easy and fast replacement of impellers in pump applications.

Table 6

Distance between shaft ends (DBSE)									
Coupling size	Distance between shaft ends (DBSE)		Spacer bush size	Bore		Coupling bush size	Bore		Designation
	Nominal min.	Nominal max.		Min	Max		Min	Max	
mm	mm	mm	mm	mm	mm	mm	mm	mm	–
40	80	90	1 210	11	32	1 008	9	25	PHE SM12-80DBSE
40	100	110	1 210	11	32	1 008	9	25	PHE SM12-100DBSE
40	100	113	1 615	14	42	1 008	9	25	PHE SM16-100DBSE
40	140	150	1 615	14	42	1 008	9	25	PHE SM16-140DBSE
50	100	116	1 615	14	42	1 210	11	32	PHE SM16-100DBSE
50	140	156	1 615	14	42	1 210	11	32	PHE SM16-140DBSE
60	100	124	1 615	14	42	1 610	14	42	PHE SM16-100DBSE
60	140	164	1 615	14	42	1 610	14	42	PHE SM16-140DBSE
70	100	114	2 517	16	60	2 012	14	50	PHE SM25-100DBSE
70	140	154	2 517	16	60	2 012	14	50	PHE SM25-140DBSE
70	180	194	2 517	16	60	2 012	14	50	PHE SM25-180DBSE
80	100	117	2 517	16	60	2 517	16	60	PHE SM25-100DBSE
80	140	157	2 517	16	60	2 517	16	60	PHE SM25-140DBSE
80	180	197	2 517	16	60	2 517	16	60	PHE SM25-180DBSE
90	140	158	2 517	16	60	2 517	16	60	PHE SM25-140DBSE
90	180	198	2 517	16	60	2 517	16	60	PHE SM25-180DBSE
100	140	158	3 020	25	75	3 020	25	75	PHE SM30-140DBSE
100	180	198	3 020	25	75	3 020	25	75	PHE SM30-180DBSE
110	140	156	3 020	25	75	3 020	25	75	PHE SM30-140DBSE
110	180	196	3 020	25	75	3 020	25	75	PHE SM30-180DBSE
120	140	160	3 525	35	100	3 525	35	100	PHE SM35-140DBSE
120	180	200	3 525	35	100	3 525	35	100	PHE SM35-180DBSE
140	140	163	3 525	35	100	3 525	35	100	PHE SM35-140DBSE
140	180	203	3 525	35	100	3 525	35	100	PHE SM35-180DBSE

Installation

- 1 Place each tapered bushing in the correct flange and tighten the screws lightly.
- 2 If keys are being used, side fitting keys with top clearance should be used.
- 3 Use a straight edge to align the face of the clamping ring for coupling sizes F40–F60 (→ fig. 1a) or the flange for coupling sizes F70–F250 (→ fig. 1b) with the shaft end. A dial indicator can be used to check that the runout of the spacer flange is within limits indicated in fig. 1a and b.

Position the SKF Flex flange on the spacer flange shaft to dimension “Y” shown in table 7 and secure it with a tapered bushing. This will allow for “M” and DBSE dimensions (→ fig. 1c) to be maintained when assembling. If necessary, the distance between shaft ends (DBSE) may be extended. The maximum DBSE possible is achieved when the spacer shaft end and driven shaft end are flush with the face of their respective tapered bushings.

- 4 Position the spacer sub-assembly in line with the spacer flange (→ fig. 1d), engage spigot align holes and insert screws. The torque values are given in table 8. Spread the tyre side walls apart and fit over the coupling flanges making sure that the tyre beads seat properly on the flanges and clamping rings.

To make sure that the tyre sits properly in position, it may be necessary to strike the outside diameter of the tyre with a small mallet. When the tyre is correctly positioned, there should be a gap between the ends of the tyre as shown in table 5.

- 5 Tighten the clamping ring screws alternately and evenly (half turn at a time), working around each flange until the required screw torque is achieved, as indicated in table 8.

To dismantle

- 1 Place a support underneath the spacer sub-assembly to prevent it from falling.
- 2 Remove clamping ring screws evenly (half turn per screw at a time) to prevent the clamping rings from distorting.
- 3 When the clamping rings are loose, remove the tyre. Then remove the remaining screws and spacer.

Table 7

Additional assembly data			
Size	“Y” for nominal DBSE		
	100	140	180
– mm			
40	83	123	–
50	82	122	–
60	75	115	155
70	76	116	156
80	74	114	154
90	111	151	–
100	111	151	–
110	115	155	–
120	111	151	–
140	104	144	–

Table 8

Clamping screw torque		
Size	Screw size	Torque
– Nm		
40	83	123
50	82	122
60	75	115
70	76	116
80	74	114
90	111	151
100	111	151
110	115	155
120	111	151
140	104	144

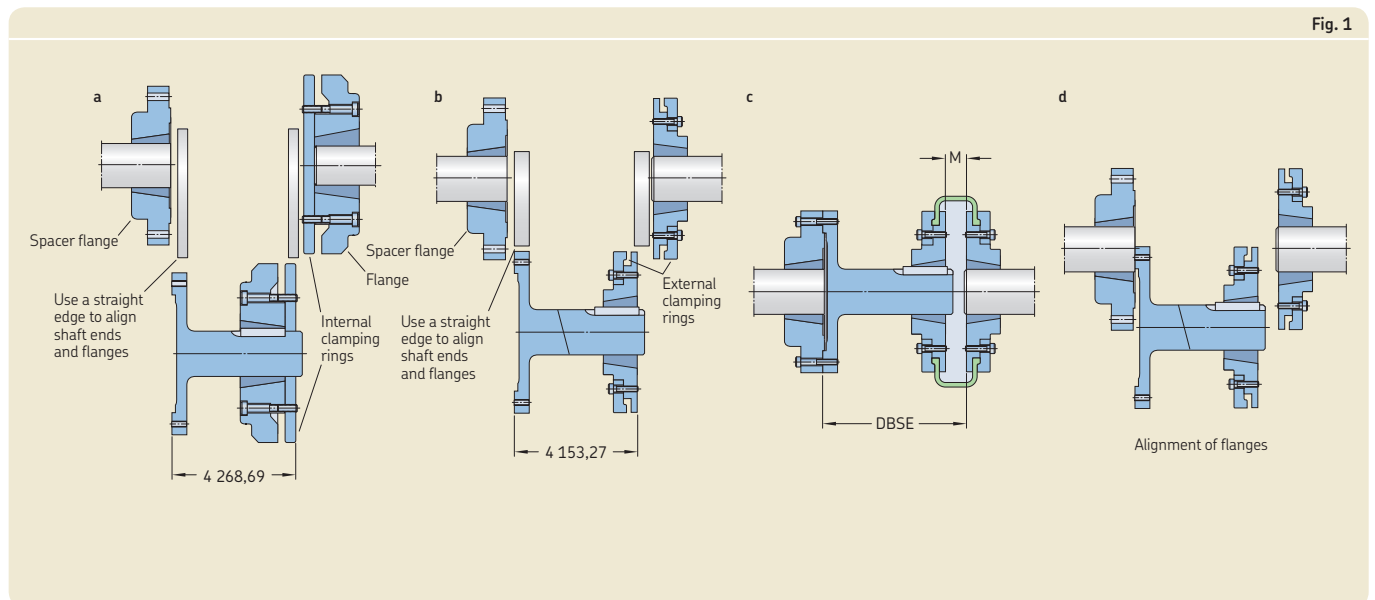
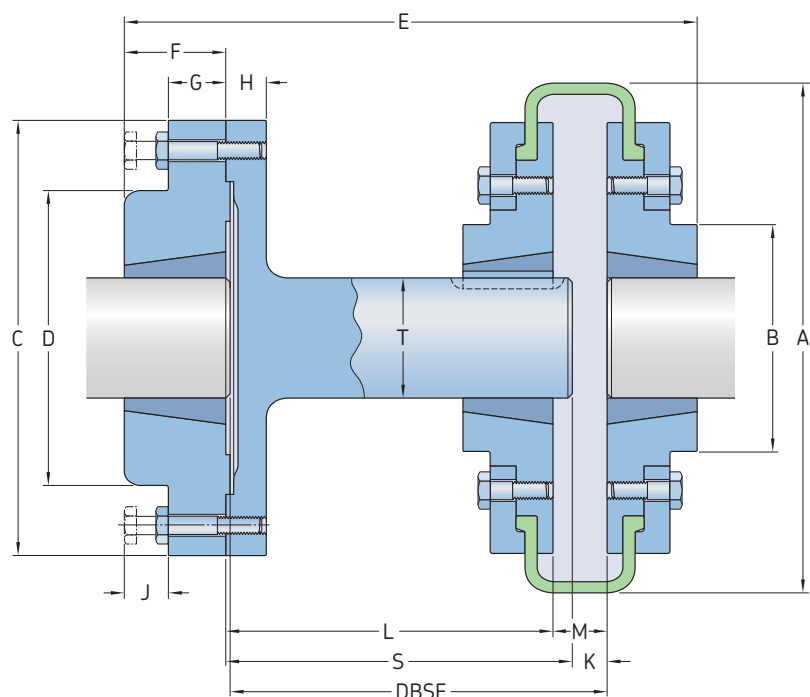

Fig. 1

SKF Flex Spacer Coupling



Coupling size	Dimensions														Designation
	A	B	C	D	E	F	G	H	J	K	L	M	S	T	
mm	mm														-
40	104	82	118	83	134	25	14	15	14	6	65	22	77	25	PHE SM12-80DBSE
40	104	82	118	83	140	25	14	15	14	22	77	22	77	25	PHE SM12-100DBSE
40 ¹⁾	104	82	127	80	157	38	18	15	14	9	88	22	94	32	PHE SM16-100DBSE
40 ¹⁾	104	82	127	80	187	38	18	15	14	9	128	22	134	32	PHE SM16-140DBSE
50	133	79	127	80	160	38	18	15	14	9	85	25	94	32	PHE SM16-100DBSE
50	133	79	127	80	200	38	18	15	14	9	125	25	134	32	PHE SM16-140DBSE
60	165	103	127	80	161	38	18	15	14	9	78	33	94	32	PHE SM16-100DBSE
60	165	103	127	80	201	38	18	15	14	9	118	33	134	32	PHE SM16-140DBSE
70 ²⁾	187	80	178	123	180	45	22	16	14	9	80	23	94	48	PHE SM25-100DBSE
70 ²⁾	187	80	178	123	220	45	22	16	14	9	120	23	174	48	PHE SM25-140DBSE
80	211	95	178	123	260	45	22	16	14	9	160	23	174	48	PHE SM25-180DBSE
80	211	95	178	123	193	45	22	16	14	9	78	25	94	48	PHE SM25-100DBSE
80	211	95	178	123	233	45	22	16	14	9	118	25	134	48	PHE SM25-140DBSE
80	211	95	178	123	273	45	22	16	14	9	158	25	174	48	PHE SM25-180DBSE
90	235	108	178	123	233	45	22	16	14	9	116	27	134	48	PHE SM25-140DBSE
90	235	108	178	123	273	45	22	16	14	9	156	27	174	48	PHE SM25-180DBSE
100	254	120	216	146	245	51	29	20	17	9	116	27	134	60	PHE SM30-140DBSE
100	254	120	216	146	285	51	29	20	17	9	156	27	174	60	PHE SM30-180DBSE
110	279	134	216	146	245	51	29	20	17	9	118	25	134	60	PHE SM30-140DBSE
110	279	134	216	146	285	51	29	20	17	9	158	25	174	60	PHE SM30-180DBSE
120	314	140	248	178	272	63	34	20	17	9	114	29	134	80	PHE SM35-140DBSE
120	314	140	248	178	312	63	34	20	17	9	154	29	174	80	PHE SM35-180DBSE
140	359	178	248	178	271	63	34	20	17	9	111	27	134	80	PHE SM35-140DBSE
140	359	178	248	178	312	63	34	20	17	9	151	27	174	80	PHE SM35-180DBSE

1) "B" Flange must be used to fit spacer shaft

2) "F" Flange must be used to fit spacer shaft

SKF Chain Couplings

Chain couplings are able to transmit higher torque than their shafts, making them ideal for high torque applications. Available with a pilot bore, finished bore or tapered bushing (face or hub), flanges are linked together with duplex roller chains enabling them to accommodate up to 2° of misalignment.

To help provide maximum service life and reliability, particularly for high speed applications, SKF recommends fitting all chain couplings with a cover and lubricating them properly. If a chain coupling is to be subjected to reversing operations, shock or pulsating loads, or other severe operating conditions, select a coupling one size larger than normal.

Selection

Standard selection method

This selection procedure can be used for most motor, turbine, or engine driven applications. The following information is required to select an SKF chain coupling:

- Torque – power [kW]
- Input speed [r/min]
- Type of equipment and application
- Shaft diameters
- Physical space limitations
- Special bore or finish requirements

1 Service factor

Determine the service factor from **table 7** and **8** on **page 60** and **61**.

2 Design power

Determine the required minimum design power as shown below:

Design power = Service factor × normal running power [kW]

Using **table 2** on **page 45**, search for the appropriate speed until a power rating greater than the design power is found. The required chain coupling size is listed at the head of the table.

3 Size

Select the appropriate coupling from the product table on **page 47** and check that chosen flanges can accommodate both driven and driving shafts.

4 Other considerations

Possible other restrictions might be speed [r/min], bore and dimensions.

Example

Select a coupling to connect a 30 kW, 1 500 r/min electric motor driving a boiler feed pump. The motor shaft diameter is 55 mm and the pump shaft diameter 45 mm. Shaft extensions are 140 mm and 110 mm respectively. The selection is replacing a gear type coupling.

1 Service factor

From **table 8** on **page 61** = 1,50

2 Required design power:

$1,5 \times 30 \text{ kW} = 45 \text{ kW}$

3 Coupling size

Look under 1 500 r/min in **table 2** on **page 45** and choose the first power figure which exceeds the required 45 kW. This is 95,2 kW of coupling size 1218.

By referring to the product table on **page 47**, it can be seen that both shaft diameters fall within the bore range available.

4 Other considerations

The speed capacity of 3 000 r/min (coupling size 1218) exceeds the required speed of 1 500 r/min. The maximum bore capacity of 62 mm exceeds the required shaft diameters of 55 mm and 45 mm. The resulting service factor is 2,11. This will provide a very good service life for the coupling and a high level of reliability.

Table 1

Coupling covers

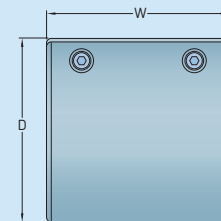

Cover size	Aluminum		Weight	Plastic		Weight
	D	W		D	W	
–	mm		kg	mm		kg
IS0816 ⁽¹⁾	102	51	0,42	102	59	0,9
IS1016 ⁽¹⁾	130	60	0,59	130	67	1,32
IS1018 ⁽¹⁾	130	60	0,59	130	67	1,32
IS1218 ⁽¹⁾	162	75	1,20	175	78	1,98
IS1220 ⁽¹⁾	162	75	1,20	175	78	1,98
IS1222 ⁽¹⁾	208	102	1,45	175	78	2,22
IS1618	208	102	1,45	210	106	2,22
IS1620	208	102	1,45	210	106	2,22
IS2018	257	133	4,80	238	151	3,97
IS2020	257	133	4,80	257	133	5,74
IS2418	289	187	8,10	289	187	7,47
IS2422	337	202	9,20	337	202	8,85

Engineering data

Power ratings

Maximum torque figures should be treated as short duration overload ratings occurring in circumstances such as direct-on-line starting.

For speeds not shown, calculate the nominal torque for the application using the following formula and select a coupling according to nominal torque ratings.

Nominal torque (Nm) =

$$\frac{\text{Design power (kW)} \times 9\,549}{\text{r/min}}$$

For additional information about chain couplings, such as chain cover data, please refer to **table 1** and **2**.

Table 2

Power ratings																							
Size	Max torque	Max r/min	Bore		kW ratings at given r/min																		
			Min.	Max.	1	5	10	25	50	100	200	300	400	500	600	800	1 000	1 200	2 500	3 000	3 600	4 000	4 800
–	Nm	r/min	mm	mm	kW																		
0816	386	5 000	16	24	0,04	0,21	0,41	1,03	2,06	3,09	4,69	6,17	7,41	8,85	10,1	12,5	15,3	17,3	31,9	37,0	43,0	46,9	54,9
1016	735	4 000	16	43	0,08	0,39	0,78	1,95	3,91	5,86	8,92	11,7	14,1	16,8	19,2	23,8	28,9	32,9	60,6	70,4	81,6	–	–
1018	931	3 600	19	51	0,10	0,50	0,99	2,48	4,95	7,43	11,3	14,9	17,8	21,3	24,4	30,1	36,6	41,6	76,8	89,2	–	–	–
1218	1 750	3 000	25,5	62	0,18	0,93	1,87	4,67	9,33	14,0	21,3	28,0	33,6	40,1	45,9	56,8	69,1	78,4	145	–	–	–	–
1220	2 060	2 500	28,5	70	0,21	1,08	2,17	5,42	10,82	16,2	24,7	32,5	38,0	46,5	53,2	65,9	80,2	90,9	168,2	–	–	–	–
1222	2 370	2 500	28,5	76	0,25	1,25	2,51	6,31	12,5	18,8	28,6	37,7	45,3	54,1	61,9	76,5	93,1	105	195	–	–	–	–
1618	3 880	2 000	28,5	80	0,41	2,07	4,14	10,3	20,7	31,0	47,2	62,1	74,5	89,0	101	126	153	174	–	–	–	–	–
1620	5 580	2 000	38	91	0,48	2,44	4,89	12,2	24,4	36,6	55,7	73,3	87,9	105,0	119,2	148,7	180,5	205,3	–	–	–	–	–
2018	7 180	1 800	38	98,5	0,62	3,13	6,25	15,6	31,3	46,8	71,3	93,8	112,5	134,4	152,6	190,3	231,1	262,8	–	–	–	–	–
2020	8 780	1 800	38	117,5	0,93	4,66	9,33	23,3	46,6	70,0	106	140	168	200	229	283	345	392	–	–	–	–	–
2418	13 200	1 500	51	119	1,40	7,02	14,0	35,1	70,2	105	160	210	252	302	345	426	519	590	–	–	–	–	–
2422	17 100	1 200	51	156	1,81	9,07	18,1	45,3	90,7	136	206	272	326	390	446	551	671	762	–	–	–	–	–

Table 3

Order data												
Size	Hub			Chain			Covers					
	Plain bore	Qty	FTB ¹⁾	Qty	HTB ¹⁾	Qty	Bored to size ²⁾	Qty	Qty	Qty		
0816	PHE IS0816RSB	2 and/or	PHE IS0816FTB	2 and/or	PHE IS0816HTB	2 and/or	PHE IS0816X...	2	PHE IS0816CHN	1	PHE IS0816COVER	2
1016	PHE IS1016RSB	2 and/or	PHE IS1016FTB	2 and/or	PHE IS1016HTB	2 and/or	PHE IS1016X...	2	PHE IS1016CHN	1	PHE IS1016COVER	2
1018	PHE IS1018RSB	2 and/or	PHE IS1018FTB	2 and/or	PHE IS1018HTB	2 and/or	PHE IS1018X...	2	PHE IS1018CHN	1	PHE IS1018COVER	2
1218	PHE IS1218RSB	2 and/or	–	2 and/or	–	2 and/or	PHE IS1218X...	2	PHE IS1218CHN	1	PHE IS1218COVER	2
1220	PHE IS1220RSB	2 and/or	PHE IS1220FTB	2 and/or	PHE IS1220HTB	2 and/or	PHE IS1220X...	2	PHE IS1220CHN	1	PHE IS1220COVER	2
1222	PHE IS1222RSB	2 and/or	–	2 and/or	–	2 and/or	PHE IS1222X...	2	PHE IS1222CHN	1	PHE IS1222COVER	2
1618	PHE IS1618RSB	2 and/or	–	2 and/or	–	2 and/or	PHE IS1618X...	2	PHE IS1618CHN	1	PHE IS1618COVER	2
1620	PHE IS1620RSB	2 and/or	PHE IS1620FTB	2 and/or	PHE IS1620HTB	2 and/or	PHE IS1620X...	2	PHE IS1620CHN	1	PHE IS1620COVER	2
2018	PHE IS2018RSB	2 and/or	–	2 and/or	–	2 and/or	PHE IS2018X...	2	PHE IS2018CHN	1	PHE IS2018COVER	2
2020	PHE IS2020RSB	2 and/or	PHE IS2020FTB	2 and/or	PHE IS2020HTB	2 and/or	PHE IS2020X...	2	PHE IS2020CHN	1	PHE IS2020COVER	2
2418	PHE IS2418RSB	2 and/or	–	2 and/or	–	2 and/or	PHE IS2418X...	2	PHE IS2418CHN	1	PHE IS2418COVER	2
2422	PHE IS2422RSB	2 and/or	–	2 and/or	–	2 and/or	PHE IS2422X...	2	PHE IS2422CHN	1	PHE IS2422COVER	2

¹⁾ Following chain coupling taper bush assembly configurations are possible: 2 hubs HTB or 2 hubs FTB or 1 hub HTB and 1 hub FTB.
²⁾ To complete bored to size designation, add bore size. For example: PHE IS1016X22MM designates hub size IS1016 with a 22 mm bore.

Order data

A complete chain coupling consists of:
2 hubs, 1 chain and 1 cover.

For additional information about ordering specific couplings, refer to **table 3**.

Installation

1 Cleaning

Clean all metal parts using non-flammable solvent and check hubs, shafts and keyways for burrs and remove if necessary. Mount the oil seal rings on the sprocket hubs. Install the sprocket hubs flush with the end of the shafts (1).

2 Gap and angular alignment

Measure the gap at various intervals and adjust to the "C" dimension specified in the product table on **page 47**. The measurement must not exceed a difference between points of more than 1° which is the allowable angular misalignment.

3 Offset alignment

Align the two hubs so that a straight edge rests squarely on both hubs (2). Repeat this at 90° intervals. Clearance must not exceed parallel misalignment of 2° which is the maximum allowable offset installation limit. Tighten all foundation bolts and repeat steps 2 and 3. Realign the coupling if necessary.

4 Lubrication

Lubricate the chain with grease. Wrap the chain around the two sprocket hubs and fix with the pin (3). Fill the cover halves with grease and insert the gaskets, install the cover and the installation is complete (4).

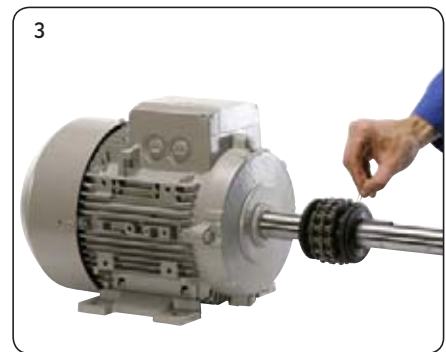
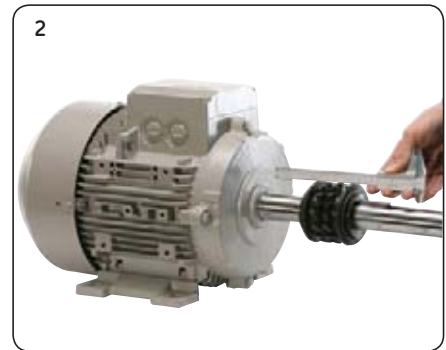
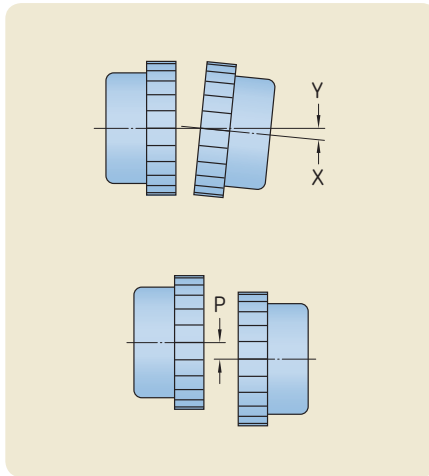

Bored-to-size and taper bushed types FTB and HTB

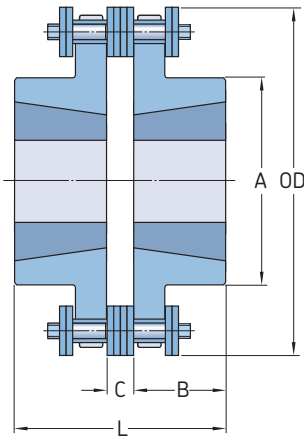

Assembly configuration HH

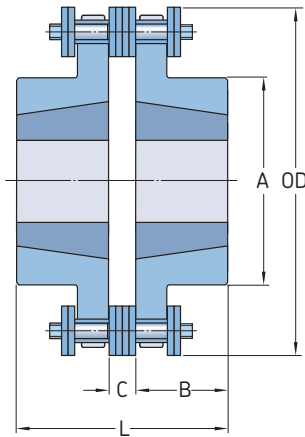

Assembly configuration FF

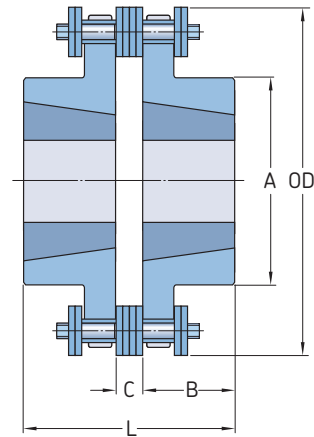

Assembly configuration FH

Coupling size	Bushing No.	Bore		Dimensions				L	OD	Weight	Max. speed	Nominal torque	Chain weight	Hub designation			
		Min.	Max.	A	B	C	Plain bore							FTB	HTB	Bored to size	
–	–	mm		mm				–	–	kg	r/min	Nm	kg	–	–	–	–
0816	1108	15,9	23,8	50,0	28,96	7,1	65,0	77,0	0,45	5 000	294	0,23	PHE IS0816RSB	–	–	PHE IS0816X...	
		12,7	28,6	50,0	22,2	7,1	51,6	77,0	0,41	5 000	294	0,23		–	PHE IS0816FTB	PHE IS0816HTB	–
1016	–	15,9	42,9	63,5	36,88	9,5	83,3	96,0	1,00	4 000	559	0,54	PHE IS1016RSB	–	–	PHE IS1016X...	
1018	1610	19,1	50,8	75,4	43,26	9,5	87,1	106,4	1,59	3 600	706	0,59	PHE IS1018RSB	–	–	PHE IS1018X...	
		12,7	41,3	75,4	25,4	9,5	60,3	106,4	0,50	3 600	706	0,59		–	PHE IS1018FTB	PHE IS1018HTB	–
1218	–	25,4	61,9	88,9	47,60	11,1	106,3	127,0	2,27	3 000	1 333	1,00	PHE IS1218RSB	–	–	PHE IS1218X...	
1220	2012	28,6	69,9	98,4	50,80	11,1	112,7	139,7	2,95	2 500	1 559	1,18	PHE IS1220	–	–	PHE IS1220X...	
		12,7	50,8	98,4	31,8	11,1	74,6	139,7	1,23	2 500	1 559	1,18		–	PHE IS1220FTB	PHE IS1220HTB	–
1222	–	28,6	76,2	114,3	54,00	11,1	119,1	151,2	4,31	2 500	1 794	1,23	PHE IS1222RSB	–	–	PHE IS1222X...	
1618	–	28,6	79,4	115,9	60,70	14,7	136,1	169,1	4,99	2 000	2 961	2,40	PHE IS1618RSB	–	–	PHE IS1618X...	
1620	3020	38,1	90,5	136,5	66,10	14,7	146,9	185,3	7,40	2 000	3 579	2,68	PHE IS1620RSB	–	–	PHE IS1620X...	
		23,8	76,2	136,5	50,0	14,7	116,3	185,3	2,77	2 000	3 579	2,68		–	PHE IS1620FTB	PHE IS1620HTB	–
2018	–	38,1	98,4	144,5	70,90	18,3	160,1	211,5	9,21	1 800	4 981	4,45	PHE IS2018RSB	–	–	PHE IS2018X...	
2020	3535	38,1	117,5	170,7	79,80	18,3	177,9	231,8	14,43	1 800	6 688	4,95	PHE IS2020RSB	–	–	PHE IS2020X...	
		30,2	88,9	170,7	88,9	18,3	196,1	231,8	8,62	1 800	6 688	4,95		–	PHE IS2020FTB	PHE IS2020HTB	–
2418	–	50,8	119,1	171,5	88,30	21,8	198,4	254,0	16,70	1 500	10 032	7,85	PHE IS2418RSB	–	–	PHE IS2418X...	
2422	–	50,8	155,6	222,3	102,10	21,8	226,0	302,0	31,76	1 200	12 993	9,62	PHE IS2422RSB	–	–	PHE IS2422X...	

SKF FRC Couplings

With a higher load capacity than jaw couplings and maintenance-free operation, FRC couplings are designed as a general purpose coupling. They are able to cushion moderate shock loads, dampen low levels of vibration and accommodate incidental misalignment. FRC couplings offer a range of hubs and elements to select, to meet the demand for low cost, general purpose spacer-type flexible coupling.

FRC couplings are phosphate coated for improved corrosion resistance and available with fire-resistant and anti-static elements (F.R.A.S.) FRC couplings are available with a pilot bore, finished bore or tapered bushing (face or hub) to make installation quick and simple.

Fully machined outside surfaces allow alignment with a simple straight edge. Shaft connections are "fail safe" due to their interlocking jaw design.

Selection

1 Service factor

Determine the required service factor from **tables 7 and 8** on **pages 60 and 61**.

2 Design power

Multiply normal running power by the service factor. This gives the design power for coupling selection.

3 Coupling size

Using FRC **table 1** on **page 49** to find the speed rating for a coupling that has a power that is greater than the design power. The required FRC coupling is listed at the head of the column.

4 Bore size

Using the FRC product table on **page 51**, check that the selected flanges can accommodate both the drive and driven shafts.

Example

An FRC coupling is required to transmit 15 kW from an electric motor running at 500 r/min to a rotary pump for 15 hours per day. The shaft diameter of the motor is 25 mm and the shaft diameter of the pump is 20 mm.

1 Service factor

From **table 7** on **page 60** = 1,75.

2 Design power

$15 \times 1,75 = 26,25$ kW

3 Coupling size

Search for 500 r/min in **table 1** on **page 49** and choose the first power figure which exceeds the required 26,25 kW. This is 31,41 kW of coupling size 150.

4 Bore size

By referring to product table on **page 51**, it can be seen that both shaft diameters fall within the bore range available.

Order data

A complete FRC coupling consists of: 2 hubs and 1 element.

For more detailed information on ordering specific couplings, refer to **table 3**.

Engineering data

Power ratings

Maximum torque figures should be treated as short duration overload ratings occurring in circumstances such as direct-on-line starting.

For speeds not shown, calculate the nominal torque for the design application using the formula below and select a coupling based on the nominal torque rating.

Nominal torque (Nm) =

$$\frac{\text{Design power (kW)} \times 9\,549}{\text{r/min}}$$

For additional information on FRC couplings, refer to **tables 1 and 2**.

Table 1

Power ratings	Coupling size							
	70	90	110	130	150	180	230	280
Speed	r/min							
	kW							
50	0,16	0,42	0,84	1,65	3,14	4,97	10,47	16,49
100	0,33	0,84	1,68	3,3	6,28	9,95	20,94	32,98
200	0,66	1,68	3,35	6,6	12,57	19,9	41,88	65,97
300	0,99	2,51	5,03	9,9	18,85	29,84	62,83	98,95
400	1,32	3,35	6,7	13,19	25,13	39,79	83,77	131,94
500	1,65	4,19	8,38	16,49	31,41	49,74	104,71	164,92
600	1,98	5,03	10,05	19,79	37,7	59,69	125,65	197,91
700	2,31	5,86	11,73	23,09	43,98	69,63	146,6	230,89
720	2,37	6,03	12,06	23,75	45,24	71,62	150,79	237,49
800	2,64	6,7	13,4	26,39	50,26	79,58	167,54	263,87
900	2,97	7,54	15,08	29,69	56,54	89,53	188,48	296,86
960	3,17	8,04	16,08	31,66	60,31	95,5	201,05	316,65
1 000	3,3	8,38	16,75	32,98	62,83	99,48	209,42	329,84
1 200	3,96	10,05	20,1	39,58	75,39	119,37	251,31	395,81
1 400	4,62	11,73	23,46	46,18	87,96	139,27	293,19	461,78
1 440	4,75	12,06	24,13	47,5	90,47	143,25	301,57	474,97
1 600	5,28	13,4	26,81	52,77	100,52	159,16	335,08	527,75
1 800	5,94	15,08	30,16	59,37	113,09	179,06	376,96	593,72
2 000	6,6	16,75	33,51	65,97	125,65	198,95	418,85	659,69
2 200	7,26	18,43	36,86	72,57	138,22	218,85	460,73	725,65
2 400	7,92	20,1	40,21	79,16	150,79	238,74	502,62	–
2 600	8,58	21,78	43,56	85,76	163,35	258,64	544,5	–
2 800	9,24	23,46	46,91	92,36	175,92	278,53	–	–
2 880	9,5	24,13	48,25	94,99	180,94	286,49	–	–
3 000	9,9	25,13	50,26	98,95	188,48	298,43	–	–
3 600	11,87	30,16	60,31	118,74	226,18	–	–	–
Nominal torque	31	80	160	315	600	950	2 000	3 150
Max. torque	72	180	360	720	1 500	2 350	5 000	7 200

Table 2

Size	Assembled length comprising flange types			Mass ¹⁾	Inertia	Torsional stiffness	Misalignment	Parallel		Nominal torque	Max torque
	FF, FH, HH	FB, HB	BB					Angular	Axial		
–	mm	mm	mm	kg	kg/m ²	Nm/°	°	mm	mm	Nm	Nm
70	65,0	65,0	65,0	1,00	0,00085	–	1	0,3	0,2	31,5	72
90	69,5	76,0	82,5	1,17	0,00115	–	1	0,3	0,5	80	180
110	82,0	100,5	119,0	5,00	0,0040	65	1	0,3	0,6	160	360
130	89,0	110,0	131,0	5,46	0,0078	130	1	0,4	0,8	315	720
150	107,0	129,5	152,0	7,11	0,0181	175	1	0,4	0,9	600	1500
180	142,0	165,5	189,0	16,60	0,0434	229	1	0,4	1,1	950	2350
230	164,5	202,0	239,5	26,00	0,1207	587	1	0,5	1,3	2000	5000
280	207,5	246,5	285,5	50,00	0,4465	1025	1	0,5	1,7	3150	7200

¹⁾ Mass is for an FF, FH or HH coupling with mid range tapered bushings.

Table 3

Order data						
Coupling type	Flanges	Qty	Element	Qty	Taper bush	Qty
RSB both sides	PHE FRC70RSB	2	PHE FRC70NR	1	–	–
	PHE FRC70FR	–	–	–	–	–
RSB/F Combination	PHE FRC70RSB	1	PHE FRC70NR or	1	PHF TB1008X...MM	1
	PHE FRC70FTB	1	PHE FRC70FR	–	–	–
RSB/H Combination	PHE FRC70RSB	1	PHE FRC70NR or	1	PHF TB1008X...MM	1
	PHE FRC70HTB	1	PHE FRC70FR	–	–	–
F/F Combination	PHE FRC70FTB	2	PHE FRC70NR or	1	PHF TB1008X...MM	1
	PHE FRC70FTB	2	PHE FRC70FR	–	PHF TB1008X...MM	1
H/H Combination	PHE FRC70HTB	1	PHE FRC70NR or	1	PHF TB1008X...MM	1
	PHE FRC70HTB	1	PHE FRC70FR	–	PHF TB1008X...MM	1
F/H Combination	PHE FRC70FTB	1	PHE FRC70NR or	1	PHF TB1008X...MM	1
	PHE FRC70HTB	1	PHE FRC70FR	–	PHF TB1008X...MM	1

NR = Natural rubber
FR = Fire-resistant and anti-static (FRAS)

Installation

- 1 Place the couplings on their shafts so that shaft ends do not protrude into the internal section of the coupling. Then tighten the screws on the tapered bushing to the torque values listed in the mounting instructions (1).
- 2 Insert the coupling element into one side of the coupling (2).
- 3 Move the other coupling into position and connect the two halves (4). Check that the assembled length is correct (5).
- 4 Check angular misalignment by measuring the assembled length in four positions at 90° around the coupling. Then check for parallel misalignment using a straight edge across the length of the coupling flange (6). Allowable angular misalignment for all FRC couplings is 1°. Allowable parallel misalignment for FRC couplings is based on size (→ table 4).

Note

For the most consistent results, check across at least 3 of the 6 points where the rubber elements are visible between the flanges.

Allowable parallel misalignment	
Coupling size	
	mm
FRC70 to 110	0,3
FRC130 to 180	0,4
FRC230 to 280	0,5

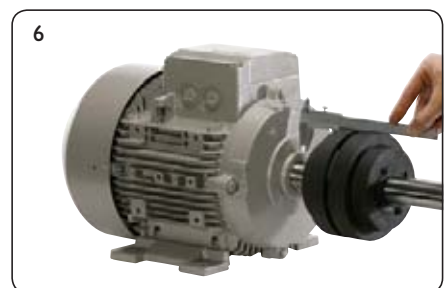
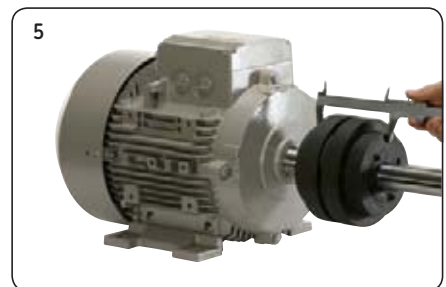
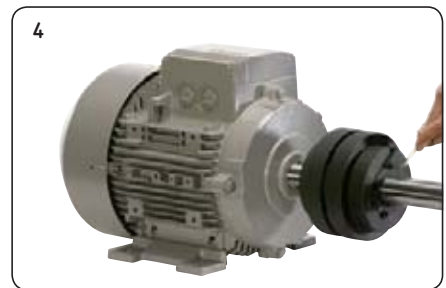
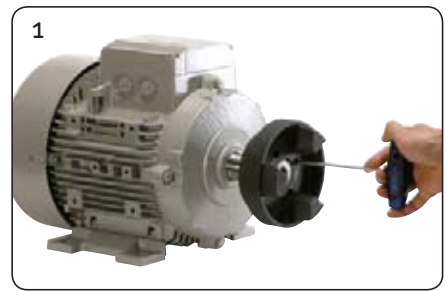

SKF FRC Couplings

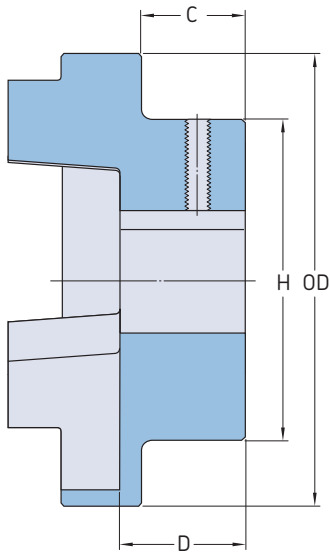

Type B

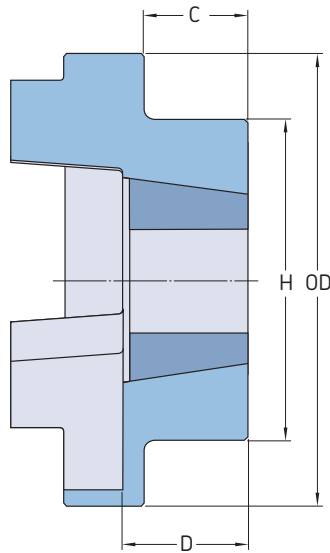

Type F

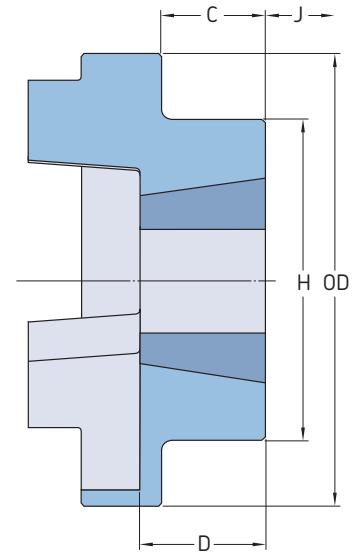

Type H

Coupling size	Dimensions		Type F, H Bushing size			C	D	J ¹⁾	Type B Bore		Key screw	C	D	Hub designation		
	OD	H	Bore Min.	Max.	Min				Max	Type F				Type H	Type B Pilot bore	
– mm																
70	69	60	1 008	9	25	20	23,5	29	32	10	M6	20	25,8	PHE FRC70FTB	PHE FRC70HTB	PHE FRC70RSB
90	85	70	1 108	9	28	19,5	23,5	29	38	10	M6	26	30,0	PHE FRC90FTB	PHE FRC90HTB	PHE FRC90RSB
110	112	100	1 610	14	42	18,5	26,5	38	55	10	M10	37	45,3	PHE FRC110FTB	PHE FRC110HTB	PHE FRC110RSB
130	130	105	1 610	14	42	18	26,5	38	60	20	M10	39	47,5	PHE FRC130FTB	PHE FRC130HTB	PHE FRC130RSB
150	150	115	2 012	14	50	23,5	33,5	42	70	28	M10	46	60,0	PHE FRC150FTB	PHE FRC150HTB	PHE FRC150RSB
180	180	125	2 517	16	60	34,5	46,5	48	80	28	M10	58	70,0	PHE FRC180FTB	PHE FRC180HTB	PHE FRC180RSB
230	225	155	3 020	25	75	39,5	52,5	55	100	45	M12	77	90,0	PHE FRC230FTB	PHE FRC230HTB	PHE FRC230RSB
280	275	206	3 525	35	100	51	66,5	67	115	55	M16	90	105,5	PHE FRC280FTB	PHE FRC280HTB	PHE FRC280RSB

¹⁾ Clearance required for tightening/loosening the bush on the shaft

SKF Jaw Couplings

Jaw couplings provide a cost-effective solution for standard power applications, cushioning moderate shock loads and dampening low vibration levels.

Maintenance-free and easy to install, jaw couplings are available with a “snap wrap” element allowing element replacement in situ.

Urethane and hytrel elements have a greater power rating than nitrile elements and are recommended for applications where a compact, high torque solution is required.

Selection

1 Service factor

Determine the required service factor in tables 7 and 8 on pages 60 and 61.

2 Design power

Multiply normal running power by the service factor. This gives the design power for selecting a coupling with a nitrile element.

3 Alternative elements

To allow coupling selection based on one power rating table (nitrile), an element correction is required to give a new reference design power. This is done by dividing the design power calculated for a nitrile element by the alternative element power factor listed in table 1.

4 Coupling size

Using table 2 on page 53, search for the appropriate speed until a power greater than the design power is found. The required jaw coupling is given at the head of the column.

5 Bore size

Using product table on page 55, check that the selected flanges can accommodate both the drive and driven shaft.

Example

A jaw coupling is required to transmit 4 kW from an electric motor running at 300 r/min to a centrifugal fan for 12 hours per day. The motor shaft is 20 mm diameter and the pump shaft diameter 18 mm.

1 Service factor

From table 7 on page 60 = 1,0.

2 Design power

Design power = $4 \times 1,0 = 4 \text{ kW}$

3 Coupling size

When looking for for 300 r/min in table 2 on page 53, the first power figure to exceed the required 4 kW of step 2 is 4,7 kW. In this case, a nitrile element can be used with a jaw coupling size 150.

4 Bore size

By referring to the product table on page 55, it can be seen that both shaft diameters fall within the bore range available.

Engineering data

Power ratings

Maximum torque figures should be treated as short duration overload ratings occurring in circumstances such as direct-on-line starting.

For speeds not shown, calculate the nominal torque for the design application using the formula below and select coupling according to nominal torque ratings.

Nominal torque (Nm) =

$$\frac{\text{Design power (kW)} \times 9\,549}{\text{r/min}}$$

For additional useful information on jaw couplings, such as standard bore and keyway data, please refer to tables 1 to 3.

Table 1

Elements Type	Temperature range	Misalignment		Power factor
		Angular	Parallel	
–	°C	°	mm	–
Nitrile	–40 to 100	1	0,38	1
Urethane	–35 to 70	1	0,38	1,5
Hytrel®	–50 to 120	0,5	0,38	3

Order data

A complete jaw coupling consists of: 2 hubs and 1 element. A complete coupling with spacer consists of 2 hubs and 1 element.

For more detailed information on ordering specific couplings, refer to table 4.

Table 2

Power ratings – Nitrile elements

Speed	Coupling sizes									
	50	70	75	90	95	100	110	150	190	225
r/min	kW									
50	0,018	0,030	0,06	0,10	0,14	0,3	0,5	0,8	1,1	1,5
100	0,037	0,060	0,12	0,20	0,27	0,6	1,1	1,6	2,1	2,9
200	0,074	0,121	0,25	0,40	0,54	1,2	2,2	3,1	4,2	5,9
300	0,110	0,181	0,37	0,60	0,81	1,7	3,3	4,7	6,3	8,8
400	0,147	0,242	0,50	0,80	1,08	2,3	4,4	6,3	8,4	11,7
500	0,184	0,302	0,62	1,01	1,35	2,9	5,5	7,9	10,5	14,7
600	0,221	0,363	0,75	1,21	1,62	3,5	6,6	9,4	12,6	17,6
700	0,257	0,423	0,87	1,41	1,89	4,1	7,7	11,0	14,7	20,5
720	0,265	0,435	0,90	1,45	1,95	4,2	7,9	11,3	15,1	21,1
800	0,294	0,483	1,00	1,61	2,16	4,6	8,8	12,6	16,8	23,5
900	0,331	0,544	1,12	1,81	2,43	5,2	9,9	14,1	18,8	26,4
960	0,353	0,580	1,20	1,93	2,59	5,6	10,6	15,1	20,1	28,1
1 000	0,368	0,604	1,25	2,01	2,70	5,8	11,0	15,7	20,9	29,3
1 200	0,441	0,725	1,50	2,41	3,24	7,0	13,2	18,8	25,1	35,2
1 400	0,515	0,846	1,74	2,81	3,78	8,1	15,4	22,0	29,3	41,1
1 440	0,529	0,870	1,79	2,90	3,89	8,4	15,8	22,6	30,2	42,2
1 600	0,588	0,967	1,99	3,22	4,32	9,3	17,6	25,1	33,5	46,9
1 800	0,662	1,088	2,24	3,62	4,86	10,4	19,8	28,3	37,7	52,8
2 000	0,735	1,208	2,49	4,02	5,40	11,6	22,0	31,4	41,9	58,6
2 200	0,809	1,329	2,74	4,42	5,94	12,8	24,2	34,6	46,1	64,5
2 400	0,882	1,450	2,99	4,83	6,48	13,9	26,4	37,7	50,3	70,4
2 600	0,956	1,571	3,24	5,23	7,02	15,1	28,6	40,8	54,5	76,2
2 800	1,029	1,692	3,49	5,63	7,56	16,2	30,8	44,0	58,6	82,1
2 880	1,059	1,740	3,59	5,79	7,78	16,7	31,7	45,2	60,3	84,4
3 000	1,103	1,813	3,74	6,03	8,10	17,4	33,0	47,1	62,8	88,0
3 600	1,323	2,175	4,49	7,24	9,73	20,9	39,6	56,5	75,4	105,5
Nominal torque Nm	3,51	5,77	11,9	19,2	25,8	55,4	105	150	200	280

Table 3

Standard bore and keyway chart

Bore	Keyway	Coupling size									
		050	070	075	090	095	100	110	150	190	225
mm	mm	-									
9	3x1,4	X	X	X	X	-	-	-	-	-	-
10	3x1,4	X	X	X	X	-	-	-	-	-	-
11	4x1,8	X	X	X	X	-	-	-	-	-	-
12	4x1,8	X	X	X	X	X	-	-	-	-	-
14	5x2,3	X	X	X	X	X	X	-	-	-	-
15	5x2,3	-	X	X	X	X	X	-	-	-	-
16	5x2,3	-	X	X	X	X	X	X	X	-	-
17	5x2,3	-	X	X	X	X	X	X	X	-	-
18	6x2,8	-	X	X	X	X	X	X	X	-	-
19	6x2,8	-	X	X	X	X	X	X	X	X	-
20	6x2,8	-	-	X	X	X	X	X	X	X	-
22	6x2,8	-	-	X	X	X	X	X	X	X	-
24	8x3,3	-	-	-	X	X	X	X	X	X	X
25	8x3,3	-	-	-	-	X	X	X	X	X	X
28	8x3,3	-	-	-	-	X	X	X	X	X	X
30	8x3,3	-	-	-	-	-	X	X	X	X	X
32	10x3,3	-	-	-	-	-	-	X	X	X	X
35	10x3,3	-	-	-	-	-	-	X	X	X	X
38	10x3,3	-	-	-	-	-	-	X	X	X	X
40	12x3,3	-	-	-	-	-	-	-	X	X	X
42	12x3,3	-	-	-	-	-	-	-	X	X	X
45	14x3,8	-	-	-	-	-	-	-	-	X	X
48	14x3,8	-	-	-	-	-	-	-	-	X	X
50	14x3,8	-	-	-	-	-	-	-	-	-	X
55	16x4,3	-	-	-	-	-	-	-	-	-	X
60	18x4,4	-	-	-	-	-	-	-	-	-	-

Table 4

Order data

Coupling type	Flanges	Qty	Element	Qty	Spacer shaft	Qty	Nitrile wrap element	Qty	Ring kit	Qty
RSB both sides	PHE L090HUB	2	PHE L090/095NR or PHE L090/095UR PHE L090/095HL	1	PHE L090X... SPACER	1	PHE L090NRWRAP	2	PHE L090RINGKIT	2
Bore with keyway/ RSB combination	PHE L090HUB PHE L090 - ... MM	1 1	PHE L090/095NR or PHE L090/095UR PHE L090/095HL	1	PHE L090X... SPACER	1	PHE L090NRWRAP	2	PHE L090RINGKIT	2
Bore with keyway on both sides	PHE L090 - ... MM	2	PHE L090/095NR or PHE L090/095UR PHE L090/095HL	1	PHE L090X... SPACER	1	PHE L090NRWRAP	2	PHE L090RINGKIT	2
Bore only/ RSB combination	PHE L090 - ... MMP PHE L090HUB	1 1	PHE L090/095NR or PHE L090/095UR PHE L090/095HL	1	PHE L090X... SPACER	1	PHE L090NRWRAP	2	PHE L090RINGKIT	2
Bore only	PHE L090 - ... MMP	2	PHE L090/095NR or PHE L090/095UR PHE L090/095HL	1	PHE L090X... SPACER	1	PHE L090NRWRAP	2	PHE L090RINGKIT	2
Bore only/bore with keyway combination	PHE L090 - ... MMP PHE L090 - ... MM	1 1	PHE L090/095NR or PHE L090/095UR PHE L090/095HL	1	PHE L090X... SPACER	1	PHE L090NRWRAP	2	PHE L090RINGKIT	2

NR = Nitrile
UR = Urethane
HL = Hytrel

Available spacer shaft lengths are 100 mm and 140 mm. To complete the designation, add spacer length. For example: PHE L090X100SPACER for spacer of 100 mm, coupling size 090.
When ordering bored to size and keywayed hubs, it is required that the bore diameter is added to the designation found in the table above.
Where a keyway is NOT required, the designation should be suffixed with a P.
PHE L150-18MM = Hub Size 150 with 18 mm bore and keyway.
PHE L070-16MMP = Hub Size 070 with 16 mm bore (no keyway).

Installation

- 1 Place each coupling on its shaft so that shaft ends do not protrude into the internal section of the coupling (1). Then tighten the set screws.
- 2 Insert the coupling element into one side of the coupling (2).
- 3 Move the other coupling side into position and connect the two halves (3). Check that the assembled length is correct (4).
- 4 Check the angular misalignment by checking the assembled length in four positions at 90° around the coupling. Check parallel misalignment using a straight edge across the length of the coupling flange (5). Allowable angular misalignment for all jaw couplings is 1°. Allowable parallel misalignment for all jaw couplings is 0,38 mm.

Note

For most consistent results, check across at least 3 of the 6 points where the rubber elements are visible between the flanges.

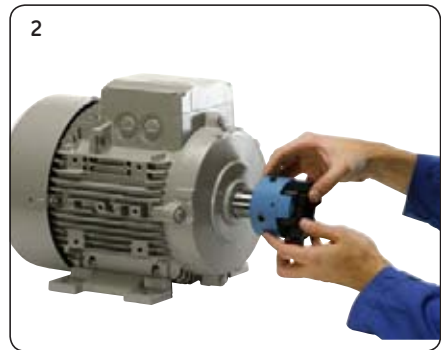

SKF Jaw Couplings

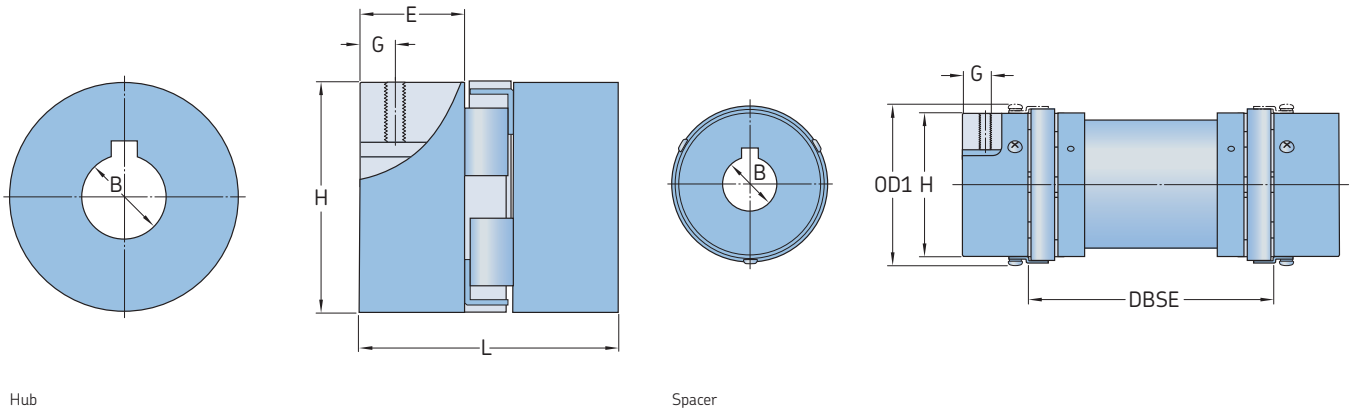

Size	Dimensions		OD	OD1 ¹⁾	L	E	H	G	Set screw	Approx. mass ²⁾	Max speed	Designation
	B Pilot	Max										
mm												
035	3,20	9,5	15,9	–	20,6	6,7	15,9	–	–	0,03	31 000	PHE L035HUB
050	6,35	14,0	27,5	–	44,0	16,0	27,5	6,5	M6	0,05	18 000	PHE L050HUB
070	6,35	19,0	35,0	–	51,0	19,0	35,0	9,5	M6	0,12	14 000	PHE L070HUB
075	6,35	24,0	44,5	–	54,0	21,0	44,5	9,0	M6	0,22	11 000	PHE L075HUB
090	6,35	24,0	54,0	–	54,0	21,0	54,0	8,7	M6	0,28	9 000	PHE L090HUB
095	11,11	28,0	54,0	64	64,0	25,0	54,0	11,0	M8	0,31	9 000	PHE L095HUB
100	12,70	35,0	65,0	77	89,0	35,0	65,0	11,0	M8	0,75	7 000	PHE L100HUB
110	15,87	42,0	84,0	97	108,0	43,0	84,0	19,0	M10	1,50	5 000	PHE L110HUB
150	15,87	48,0	96,0	112	115,0	45,0	96,0	22,0	M10	2,40	4 000	PHE L150HUB
190	19,05	55,0	115,0	130	133,0	54,0	102,0	22,0	M12	3,50	3 600	PHE L190HUB
225	19,05	60,0	127,0	143	153,0	64,0	108,0	29,0	M12	4,50	3 600	PHE L225HUB

¹⁾ Outer diameter of ring kit

²⁾ Mass of hub with pilot bores

DBSE = Distance between shaft ends

Hub material is high grade cast iron. Spacer material is aluminium.

SKF Universal Joints

Universal joints, also known as pin and block couplings, are commonly used for low to medium torque industrial, off-road and agricultural applications.

These couplings offer an economical solution for applications up to 1 800 r/min and will provide working angles of up to 25° or 35° for manual drives. SKF offers these couplings with a solid bore from stock, bored to size, square, hexagonal and round bores on request. The couplings are available in either a single (UJMA) or double (UJMB) configuration.

Selection

Universal joints are selected based on torque. The following application information is required:

- Torque – power [kW]
- Speed [r/min]
- Joint angle [°]

The product tables on **page 57** provide maximum allowable torque (expressed in Nm) based on a 10° angle of inclination and continuous use.

However, if the inclination angle is not 10°, the values shown will be reduced or increased in accordance with the torque factors listed in **table 1**.

Torque is calculated using the following formula:

$$\text{Nominal torque (Nm)} = \frac{\text{Design power (kW)} \times 9\,549}{\text{r/min}}$$

Example

An electric motor is driving a small gearbox. The application has the following basic data.

- Power = 3 kW
- Speed = 1500 r/min
- Joint angle = 20°

1 Determine the basic required torque

$$\frac{3 \text{ kW} \times 9\,549}{1\,500 \text{ r/min}} = 19,1 \text{ Nm}$$

2 Adjust the torque value to accommodate a 20° angle of inclination. **Table 1** lists a correction value of 0,75. The previously calculated basic torque rating must be divided by the correction factor in order to get the adjusted torque value. In other words, a joint with larger dimensions must be selected as the angle is greater than 10°.

$$\frac{19,1 \text{ kW}}{0,75 \text{ kgm}} = 24,46 \text{ Nm}$$

3 From product table on **page 57**, the joint size UJMA13 is the proper selection.

Engineering data

For additional information about universal joints, refer to **table 1**.

Order data

Standard universal joints are without bore. For additional information about ordering specific universal joints, refer to **table 2**.

Table 1

Maximum allowable torque	
Angle up to	Factor F
–	kgm
5°	1,25
10°	1
20°	0,75
30°	0,45
40°	0,30

Table 2

Order data		
Universal joint type	Size	Qty
Single	PHE UJMA10	1
Double	PHE UJMB20	1

Available on request with finish bore, finish bore with keyway, hexagonal bore or square bore, e.g. the designations as shown below.

Universal joints with finish bore H7, with keyway (BSX30MM)
 – PHE UJMB45BSX30MM
 Universal joints with finish bore H7, without keyway (X30MM)
 – PHE UJMB45X30MM
 Universal joints with hexagonal bore (HBX30MM)
 – PHE UJMB45HBX30MM
 Universal joints with square bore (SBX30MM)
 – PHE UJMB45SBX30MM

Single universal joints

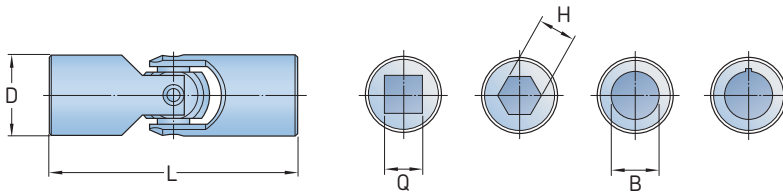

Size	L	D	Bore			B Max		Static breaking torque	Designation
			B	Q	H	Bore	With keyway		
–	mm					mm	Nm	–	
10	38	10	6	6	6	6	–	PHE UJMA10	
13	45	13	8	8	8	8	–	PHE UJMA13	
16	52	16	8	8	8	10	8	PHE UJMA16	
20	62	20	10	10	10	13	11	PHE UJMA16	
25	74	25	12	12	12	16	14	PHE UJMA25	
32	86	32	16	16	16	22	18	PHE UJMA32	
40	108	40	20	20	20	25	22	PHE UJMA40	
45	120	45	20	20	20	30	25	PHE UJMA45	
50	132	50	25	25	25	35	30	PHE UJMA50	
63	166	63	32	32	–	45	35	PHE UJMA63	
75	190	75	40	40	–	55	45	PHE UJMA75	

Standard is without bore.

Available on request with finish bore H7 – on request with keyway (B), hexagonal bore (H) or square bore (Q)

Double universal joints

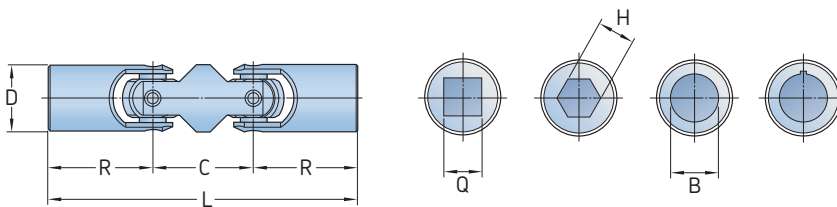

Size	Dimensions					B _{Max} Bore	With keyway	Q	H	Static breaking torque	Designation
	L	R	E Min	D	C						
–	mm									Nm	–
13	68	22,5	13	23	8	8	8	–	–	26	PHE UJMB13
16	77	26	16	25	8	8	8	10	8	45	PHE UJMB16
20	92	31	20	30	10	10	10	13	11	88	PHE UJMB20
25	110	37	25	36	12	12	12	16	14	180	PHE UJMB25
32	133	43	32	47	16	16	16	22	18	405	PHE UJMB32
40	164	54	40	56	20	20	20	25	22	860	PHE UJMB40
45	183	60	45	63	20	20	20	30	25	1 250	PHE UJMB45
50	202	66	50	70	25	25	25	35	30	1 730	PHE UJMB50
63	250	83	63	84	32	32	–	45	35	3 400	PHE UJMB63
75	290	95	75	100	40	40	–	55	45	5 300	PHE UJMB75

Standard is without bore.

Available on request with finish bore H7 – on request with keyway (B), hexagonal bore (H) or square bore (Q)

General engineering data on SKF Couplings

Table 1

Recommended shaft diameter/key combinations for bore with one key, DIN 6885 part 1

Nominal shaft diameter		Key		A*		B*	
Over	Up to	Over	Up to	Width	Height	For shaft	For hub
mm		in.		mm		mm	
6	8	0,24	0,31	2	2	1,1/1,3	1,0/1,1
8	10	0,31	0,39	3	3	1,8/1,9	1,4/1,5
10	12	0,39	0,47	4	4	2,5/2,6	1,8/1,9
12	17	0,47	0,67	5	5	3,0/3,1	2,3/2,4
17	22	0,67	0,87	6	6	3,5/3,6	2,8/2,9
22	30	0,87	1,18	8	7	4,0/4,2	3,3/3,5
30	38	1,18	1,50	10	8	5,0/5,2	3,3/3,5
38	44	1,50	1,73	12	8	5,0/5,2	3,3/3,5
44	50	1,73	1,97	14	9	5,5/5,7	3,8/4,0
50	58	1,97	2,28	16	10	6,0/6,2	4,3/4,5
58	65	2,28	2,56	18	11	7,0/7,2	4,4/4,6
65	75	2,56	2,95	20	12	7,5/7,7	4,9/5,1
75	85	2,95	3,35	22	14	9,0/9,2	5,4/5,6
85	95	3,35	3,74	25	14	9,0/9,2	5,4/5,6
95	110	3,74	4,33	28	16	10,0/10,2	6,4/6,6
110	130	4,33	5,12	32	18	11,0/11,2	7,4/7,6
130	150	5,12	5,91	36	20	12,0/12,3	8,4/8,7
150	170	5,91	6,69	40	22	13,0/13,3	9,4/9,7
170	200	6,69	7,87	45	25	15,0/15,3	10,4/10,7
200	230	7,87	9,06	50	28	17,0/17,3	11,4/11,7
230	260	9,06	10,24	56	32	20,0/20,3	12,4/12,7
260	290	10,24	11,42	63	32	20,0/20,3	12,4/12,7
290	330	11,42	12,99	70	36	22,0/22,3	14,4/14,7
330	380	12,99	14,96	80	40	25,0/25,3	15,4/15,7

* Using A and B dimensions given will allow proper headroom clearance. Recommended tolerance on keyway width is +0,05/-0 mm (+0.002/-0 in.)

Table 2

Recommended shaft diameter/key combinations for bores with one key, ANSI B17.1

Nominal shaft diameter		Rectangular key		Square key	
Over	Up to	Width	Height	Width	Height
in.		in.		in.	
5/16	7/16	—	—	3/32	3/32
7/16	9/16	1/8	3/32	1/8	1/8
9/16	7/8	3/16	1/8	3/16	3/16
7/8	1 1/4	1/4	3/16	1/4	1/4
1 1/4	1 3/8	5/16	1/4	5/16	5/16
1 3/8	1 3/4	3/8	1/4	3/8	3/8
1 3/4	2 1/4	1/2	3/8	1/2	1/2
2 1/4	2 3/4	5/8	7/16	5/8	5/8
2 3/4	3 1/4	3/4	1/2	3/4	3/4
3 1/4	3 3/4	7/8	5/8	7/8	7/8
3 3/4	4 1/2	1	3/4	1	1
4 1/2	5 1/2	1 1/4	7/8	1 1/4	1 1/4
5 1/2	6 1/2	1 1/2	1	1 1/2	1 1/2
6 1/2	7 1/2	1 3/4	1 1/2	1 3/4	1 3/4
7 1/2	9	2	1 1/2	2	2
9	11	2 1/2	1 3/4	2 1/2	2 1/2
11	13	3	2	3	3
13	15	3 1/2	2 1/2	3 1/2	3 1/2
15	18	4	3	4	4

A minimum headroom clearance of 0.005 in. is recommended. Recommended tolerance on keyway width is +0/-0.002 in.

Table 3

Recommended bore tolerances for SKF steel coupling hubs

Shaft diameters		Bore diameter tolerances		
Nominal	Tolerance	Clearance	Standard	Interference
mm		—	—	—
6 – 30	k6	F7	H7	M6
31 – 50	k6	F7	H7	K6
51 – 80	m6	F7	H7	K7
81 – 100	m6	F7	H7	M7
101 – 200	m6	F7	H7	P7
201 – 355	m6	F7	H7	R7
356 – 500	m6	F7	H7	R8

Table 4

Recommended bore tolerances for SKF steel coupling hubs





Torque demands driven equipment	Typical applications for electric motors	Service factor
	Constant torque centrifugal pumps, blowers and compressors.	1,0
	Continuous duty, some torque variations such as plastic extruders and forced draft fans.	1,5
	Light shock loads, such as metal extruders, cooling towers and log hauling.	2,0
	Moderate shock loads, such as rock crushers, rail car dumpers and vibrating screens.	2,5
	Heavy shock loads, such as roughing mills, reciprocating pumps and reversing runout tables.	3,0

Table 5

Shaft diameters and ratings for NEMA 60 Hertz

T frames

Frame size	Shaft diameter	3 600 r/min		1 800 r/min		1 200 r/min		900 r/min	
		Drip proof	Enclosed	Drip proof	Enclosed	Drip proof	Enclosed	Drip proof	Enclosed
–	in.	hp		hp		hp		hp	
143	0,88	1½	1½	1	1	¾	¾	½	½
145	0,88	2-3	2	1½-2	1½-2	1	1	¾	¾
182	1,13	5	3	3	3	1½	1½	1	1
184	1,13	7½	5	5	5	2	2	1½	1½
213	1,38	10	7½	7½	7½	3	3	2	2
215	1,38	15	10	10	10	5	5	3	3
254	1,63	20	15	15	15	7½	7½	5	5
256	1,63	25	20	20	20	10	10	7½	7½
284	1,88	30	25	25	25	15	15	10	10
286	1,88	40	30	30	30	20	20	15	15
324	2,13	50	40	40	40	25	25	20	20
326	2,13	60	50	50	50	30	30	25	25
364	2,38	75	60	60	60	40	40	30	30
365	2,38	100	75	75	75	50	50	40	40
404	2,88	125	–	100	–	60	60	50	50
405	2,88	150	100	125	100	75	75	60	60
444	3,38	200	125	150	125	100	100	75	75
445	3,38	250	150	200	150	125	125	100	100

T frames

Frame size	Shaft diameter	3 600 r/min		1 800 r/min		1 200 r/min		900 r/min	
		Drip proof	Enclosed	Drip proof	Enclosed	Drip proof	Enclosed	Drip proof	Enclosed
–	in.	hp		hp		hp		hp	
284	1,63	30	25	25	25	15	15	10	10
286	1,63	40	30	30	30	20	20	15	15
324	1,88	50	40	40	40	25	25	20	20
326	1,88	60	50	50	50	30	30	25	25
364	1,88	75	60	60	60	40	40	30	30
365	1,88	100	75	75	75	50	50	40	40
404	2,13	125	–	100	–	60	60	50	50
405	2,13	150	100	125	100	75	75	60	60
444	2,38	200	125	150	125	100	100	75	75
445	2,38	250	150	200	150	125	125	100	100

Table 6

Shaft diameters and ratings for metric foot mounted motor (IEC)

Frame size	Shaft diameter	3 000 r/min		1 500 r/min		1 000 r/min		750 r/min	
		kW	kW	kW	kW	kW	kW	kW	kW
–	mm	kW		kW		kW		kW	
80	19	0,75 – 1,10	0,55 – 0,75	0,37 – 0,55	0,18 – 0,25				
90S	24	1,5	1,1	0,75	0,37				
90L	24	2,2	1,5	1,1	0,55				
100L	28	3,0	2,2, 3,0	1,5	0,75, 1,1				
112M	28	4,0	4,0	2,2	1,5				
132S	38	5,5 – 7,5	5,5	3,0	2,2				
132M	38	–	7,5	4,0 – 5,5	3,0				
160M	42	11 – 15	11,0	7,5	4,0 – 5,5				
160L	42	18,5	15,0	11,0	7,5				
180M	48	22	18,5	–	–				
180L	48	–	22,0	15,0	11,0				
200M/L	55	30 – 37	30	18,5 – 22	15,0				
225S	55, 60	45	37 – 45	30	18,5				
225M	55, 60	45	45	30	22				
250S	60, 65, 70	55	55	37	30				
250M	60, 65, 70	55 – 75	55 – 75	37 – 45	30 – 37				
280S	65, 75, 80	75 – 90	75 – 90	45 – 50	37 – 45				
280M	65, 75, 80	90 – 110	90 – 110	55 – 75	45 – 55				

Service factors by application

Application	Electric motor with standard torque			Application	Electric motor with standard torque			Application	Electric motor with standard torque		
	Reciprocating engine with 6 or more cylinders	Reciprocating engine with 4/5 cylinders			Reciprocating engine with 6 or more cylinders	Reciprocating engine with 4/5 cylinders			Reciprocating engine with 6 or more cylinders	Reciprocating engine with 4/5 cylinders	
Aerator	2,0	2,5	3,0	Elevators				Mixers (see agitators)			
Agitators				Bucket, centrifugal discharge	1,25	1,75	2,25	Concrete	1,75	2,25	2,75
Vertical and horizontal	1,0	1,5	2,0	Freight or passenger	Not approved			Muller	1,5	2,0	2,5
Screw, propeller, paddle	1,5	2,0	2,5	Gravity discharge	1,25	1,75	2,25	Press, printing	1,5	2,0	2,5
Barge haul puller				Escalators	Not approved			Pug mill	1,75	2,25	2,75
Blowers				Exciter, generator	1,0	1,5	2,0	Pulverizers			
Centrifugal	1,0	1,5	2,0	Extruder, plastic	1,5	2,0	2,5	Hammermill and hog	1,75	2,25	2,75
Lobe or vane	1,25	1,75	2,25	Fans				Roller	1,5	2,0	2,5
Car dumpers	2,5	*	*	Centrifugal	1,0	1,5	2,0	Pumps			
Car pullers	1,5	2,0	2,5	Cooling tower	2,0	2,5	3,0	Boiler feed	1,5	2,0	2,5
Clarifier or classifier	1,0	1,5	2,0	Forced draft – across the lines start	1,5	2,0	2,5	Centrifugal			
Clay working machines				Forced draft motor				Constant speed	1,0	1,5	2,0
Brick press	1,75	2,25	2,75	Driven through fluid or electric slip clutch	1,0	1,5	2,0	Frequent speed changes under load	1,25	1,75	2,25
Pug mill	1,75	2,25	2,75	Gas recirculating	1,5	2,0	2,5	Descaling, with accumulators	1,25	1,75	2,25
Briquett machine	1,75	2,25	2,75	Induced draft with damper control or blade cleaner	1,25	1,75	2,25	Gear, rotary, or vane	1,25	1,75	2,25
Compressors				Induced draft without controls	2,0	2,5	3,0	Reciprocating, plunger, piston			
Centrifugal	1,0	1,5	2,0	Feeder				1 cylinder, single or double acting	3,0	*	*
Rotary, lobe or vane	1,25	1,75	2,25	Apron, belt, disc, screw	1,0	1,5	2,0	2 cylinders, single acting	2,0	2,5	3,0
Rotary, screw	1,0	1,5	2,0	Reciprocating	2,5	3,0	3,5	2 cylinders, double acting	1,75	2,25	2,75
Reciprocating				Generators				3 or more cylinders	1,5	2,0	2,5
Direct connected	Contact SKF			Even load	1,0	1,5	2,0	Screw pump, progressing cavity	1,25	1,75	2,25
Without flywheel	Contact SKF			Hoist or railway service	1,5	2,0	2,5	Vacuum pump	1,25	1,75	2,25
With flywheel and gear between compressor and prime mover				Welder load	2,0	2,5	3,0	Screens			
1 cylinder, single acting	3,0	*	*	Hammermill	1,75	2,25	2,75	Air washing	1,0	1,5	2,0
1 cylinder, double acting	3,0	*	*	Kiln	2,0	2,5	3,0	Grizzly	2,0	2,5	3,0
2 cylinders, single acting	3,0	*	*	Laundry washer or tumbler	2,0	2,5	3,0	Rotary coal or sand	1,5	2,0	2,5
2 cylinders, double acting	3,0	*	*	Line shafts				Vibrating	2,5		
3 cylinders, single acting	3,0	*	*	Any processing machinery	1,5	2,0	2,5	Water	1,0	1,5	2,0
3 cylinders, double acting	2,0	2,5	3,0	Machine tools				Ski tows and lifts	Not approved		
4 or more cylinder, single acting	1,75	2,25	2,75	Auxiliary and traverse drive	1,0	1,5	2,0	Steering gear	1,0	1,5	2,0
4 or more cylinder, double acting	1,75	2,25	2,75	Bending rolls, notching press				Stoker	1,0	1,5	2,0
Conveyors				Punch press, planer, plate				Tire shredder	1,5	2,0	2,5
Apron, assembly, belt, chain	1,0	1,5	2,0	Reversing	1,75	2,25	2,75	Tumbling barrel	1,75	2,25	2,75
Bucket flight, screw	1,25	1,75	2,25	Main drive	1,5	2,0	2,5	Winch, maneuvering			
Live roll, shaker	1,0	1,5	2,0	Man lifts	Not approved			Dredge, marine	1,5	2,0	2,5
Inclined belt and screw	3,0	*	*	Mills (rotary type)				Wind turbines	1,25	1,75	2,25
Reciprocating	1,75	2,25	2,75	Ball or pebble	2,0	2,5	3,0	Windlass	1,5	2,0	2,5
Main hoist	1,75	2,25	2,75	Rod or tube	2,0	2,5	3,0	Woodworking machinery	1,0	1,5	2,0
Skip hoist	1,5	2,0	2,5	Metal forming machines				Work lift platforms	Not approved		
Slope	1,75	2,25	2,75	Dryer and cooler	1,75	2,25	2,75				
Bridge, travel or trolley	2,5	*	*	Continuous caster	1,75	2,25	2,75				
Cranes and hoist	1,75	2,25	2,75	Draw bench carriage and main drive	2,0	2,5	3,0				
Crushers				Extruder	2,0	2,5	3,0				
Cable reel	1,25	1,75	2,25	Forming machine and forming mills	2,0	2,5	3,0				
Dredges				Slitters	1,0	1,5	2,0				
Conveyors	2,0	2,5	3,0	Wire drawing or flattening	1,75	2,25	2,75				
Cutter head, jig drive	1,5	2,0	2,5	Wire winder	1,5	2,0	2,5				
Maneuvering winch	1,5	2,0	2,5	Coilers and uncoilers	1,5	2,0	2,5				
Pumps (uniform load)	1,75	2,25	2,75								
Dynamometer											
Screen drive, stacker	1,5	2,0	2,5								
Utility winch	1,0	1,5	2,0								

* For balanced opposed design, contact SKF
If people are occasionally transported, contact SKF for the selection of the proper size of the coupling
For high peak load applications (such as metal rolling mills), contact SKF

Table 8

Service factors by industry

Application	Electric motor with standard torque			Application	Electric motor with standard torque	Reciprocating engine with 6 or more cylinders	Reciprocating engine with 4/5 cylinders	Application	Electric motor with standard torque	Reciprocating engine with 6 or more cylinders	Reciprocating engine with 4/5 cylinders
	Reciprocating engine with 6 or more cylinders	Reciprocating engine with 4/5 cylinders	Reciprocating engine with 4/5 cylinders								
Aggregate processing,											
Cement, mining kilns;				Hot mills				Couch	1,75	2,25	2,75
Tube, rod and ball mills				Strip or sheet mills	Contact SKF			Cutter, flet whipper	2,0	2,5	3,0
Direct or on low speed shaft of reducer, with final drive machined spur gears	2,0	2,5	3,0	Reversing blooming	Contact SKF			Cylinder	1,75	2,25	2,75
				Slabbing mills	Contact SKF			Dryer	1,75	2,25	2,75
				Edger drives	Contact SKF			Felt stretcher	1,25	1,75	2,25
Single helical or herringbone gears	1,75	2,25	2,75	Hot mills				Fourdrinier	1,75	2,25	2,75
				Strip or sheet mills	Contact SKF			Jordan	2,0	2,5	3,0
Conveyors, feeders, screens, elevators	See general listing			Reversing blooming	Contact SKF			Log haul	2,0	2,5	3,0
Crushers, ore or stone	2,5	*	*	Slabbing mills	Contact SKF			Line shaft	1,5	2,0	2,5
Dryer, rotary	1,75	2,25	2,75	Edger drives	Contact SKF			Press	1,75	2,25	2,75
Grizzly	2,0	2,5	3,0	Ingot cars	2,0	2,5	3,0	Pulp grinder	1,75	2,25	2,75
Hammermill or hog	1,75	2,25	2,75	Manipulators	3,0	*	*	Reel, rewinder, winder	1,5	2,0	2,5
Tumbling mill or barrel	1,75	2,25	2,75	Merchant mills	Contact SKF			Stock chest, washer, thickener	1,5	2,0	2,5
Brewing and distilling											
Bottle and can filling machines	1,0	1,75	2,0	Mill tables				Stock pumps, centrifugal			
Brew kettle	1,0	1,5	2,0	Roughing breakdown mills	3,0	*	*	Constant speed	1,0	1,5	2,0
Cookers, continuous duty	1,25	2,0	2,0					Frequent speed changes under load	1,25	1,75	2,25
Lauter tub	1,5	2,0	2,5	Hot bed or transfer, non-reversing	1,5	2,0	2,5	Suction roll	1,75	2,25	2,75
Mash tub	1,25	1,75	2,0	Runout, reversing	3,0	*	*	Vacuum pumps	1,25	1,75	2,25
Scale hopper, frequent peaks	1,75	2,25	2,75	Runout, non-reversing, non-plugging	2,0	2,5	3,0	Rubber industry			
Clay working industry											
Brick press, briquette machine, clay working machine,	1,75	2,25	2,75	Reel drive	1,75	2,25	2,75	Calender	2,0	2,5	3,0
Pug mill	1,75	2,25	2,75	Rod mills	Contact SKF			Cracker, plasticator	2,5	*	*
Food industry											
Beet slicer	1,75	2,25	2,75	Screwdown	2,0	2,5	3,0	Extruder	1,75	2,25	2,75
Bottling, can filling machine	1,0	1,5	2,0	Seamless tube mills				Intensive or banbury mixer	2,5	*	*
Cereal cooker	1,25	1,75	2,0	Piercer	3,0	*	*	Mixing mill, refiner or sheeter			
Dough mixer, meat grinder	1,75	2,25	2,75	Thrust block	2,0	2,5	3,0	One or two in line	2,5	*	*
Lumber											
Band resaw	1,5	2,0	2,5	Tube conveyer rolls	2,0	2,5	3,0	Three or four in line	2,0	2,5	3,0
Circular resaw, cut-off	1,75	2,25	2,75	Reeler	2,0	2,5	3,0	Five or more in line	1,75	2,25	2,75
Edger, head rig, hog	2,0	2,5	3,0	Kick out	2,0	2,5	3,0	Tire building machine	2,5	*	*
Edger, head rig, hog	2,0	2,5	3,0	Shear, croppers	Contact SKF			Tire & tube press opener (peak torque)	1,0	1,5	2,0
Gang saw (reciprocating)	Contact SKF			Sideguards	3,0	*	*	Tuber, strainer, pelletizer	1,75	2,25	2,75
Log haul	2,0	2,5	3,0	Skelp mills	Contact SKF			Warming mill			
Planer	1,75	2,25	2,75	Slitters, steel mill only	1,75	2,25	2,75	One or two mills in line	2,0	2,5	3,0
Rolls, non-reversing	1,25	1,75	2,0	Soaking pit cover drives				Three or more mills in line	1,75	2,25	2,75
Rolls, reversing	2,0	2,5	3,0	Lift	1,0	1,5	2,0	Washer	2,5	*	*
Sawdust conveyor	1,25	1,75	2,0	Travel	2,0	2,5	3,0	Sewage disposal equipment			
Slab conveyor	1,75	2,25	2,75	Straighteners	2,0	2,5	3,0	Bar screen, chemical feeders,			
Sorting table	1,5	2,0	2,5	Unscramblers (billet bundle busters)	2,0	2,5	3,0	Collectors dewatering			
Trimmer	1,75	2,25	2,75	Wire drawing machinery	1,75	2,25	2,75	Screen, grit collector	1,0	1,5	2,0
Metal rolling mills											
Coilers (up or down) cold mills only	1,5	2,0	2,5	Oil industry				Sugar industry			
Coilers (up or down) hot mills only	2,0	2,5	3,0	Chiller	1,25	1,75	2,25	Cane carrier & leveler	1,75	2,25	2,75
Coke plants				Oilwell pumping (not over 150% peak torque)	2,0	2,5	3,0	Cane knife & crusher	2,0	2,5	3,0
Pusher ram drive	2,5	*	*	Paraffin filter press	1,5	2,0	2,5	Mill stands, turbine driver with all helical or herringbone gears	1,5	2,0	2,5
Door opener	2,0	2,5	3,0	Rotary kiln	2,0	2,5	3,0	Electric drive or steam engine			
Pusher or larry car traction drive	3,0	*	*	Paper mills				Drive with helical, herringbone, or spur gears with any prime mover	1,75	2,25	2,75
Continuous caster	1,75	2,25	2,75	Barker auxiliary, hydraulic	2,0	2,5	3,0	Textile industry			
Cold mills				Barker, mechanical	2,0	2,5	3,0	Batcher	1,25	1,75	2,25
Strip mills	Contact SKF			Barking drum				Calender, card machine	1,5	2,0	2,5
Temper mills	Contact SKF			L, S, shaft of reducer with final drive				Cloth finishing machine	1,5	2,0	2,5
Cooling beds	1,5	2,0	2,5	Helical or herringbone gear	2,0	2,5	3,0	Dry can, loom	1,5	2,0	2,5
Drawbench	2,0	2,5	3,0	Machined spur gear	2,5	*	*	Dyeing machinery	1,25	1,75	2,25
Feed rolls – blooming mills	3,0	*	*	Cast tooth spur gear	3,0	*	*	Knitting machine	Contact SKF		
Furnace pushers	2,0	2,5	3,0	Beater and pulper	1,75	2,25	2,75	Mangle, napper, soaper	1,25	1,75	2,25
Hot and cold saws	2,0	2,5	3,0	Bleachers, coaters	1,0	1,5	2,0	Spinner, tenter frame, winder	1,5	2,0	2,5

* For balanced opposed design, contact SKF
If people are occasionally transported, contact SKF for the selection of the proper size coupling
For high peak load applications (such as metal rolling mills), contact SKF

Lubrication

A sufficient supply of lubricant is vital to satisfactory operation. A list of typical lubricants and specifications for general purpose and long term grease is available below. Using general purpose grease requires annual re-lubrication of the coupling.

General purpose grease

The specifications and lubricants in **table 1** and **2** are for general purpose grease, whereas the specifications and lubricants in **table 3** apply to SKF Gear Couplings. These specifications apply to couplings that are lubricated annually and that operate at temperatures between 0 to 150 °F (–18 to 66 °C). For temperatures beyond this range, consult SKF.

If couplings leak grease, are exposed to extreme temperatures or excessive moisture or experience frequent reversals, more frequent lubrication may be required.

Specifications:

- Dropping point – 300 °F (149 °C) or higher
- Consistency – NLGI 2 with worked penetration value in the range of 250–300 (10⁻¹ mm).
- Separation and resistance – low oil separation rate and high resistance to separation from centrifuging.
- Liquid constituent – should possess good lubricating properties, equivalent to high quality, well refined, petroleum oil.
- Inactive – must not corrode steel or cause swelling or deterioration of synthetic seals.

Table 1

General purpose grease		
Ambient temperature range	0 to 150 °F (–18 to +66 °C)	–30 to 100 °F* (–34 to +38 °C)
NLGI grade manufacturer	#2 lubricant	#2 lubricant
SKF	LGEP 2	LGEP 2
Gulf Oil Corp.	Gulfcrown Grease #2	Gulfcrown Grease #2
Mobil Oil Corp.	Mobilux #2	Mobilux #1
Phillips Petroleum Co.	IB and RB Grease	Philube IB and RB Grease
Shell Oil Co.	Alvania Grease #2	Alvania Grease #2

* For northern climate applications. For continuous operation at constant ambient temperatures less than 0 °F or –18 °C (for example refrigeration systems) consult SKF.

Table 2

NLGI 1 grease	
Coupling speed range:	See table 3
Temperature range:	–30 to +200°F* (–34 to +93°C)
Manufacturer	Lubricant
SKF	LGWM 1
Mobil Oil Corp.	Mobilux EP1
Phillips Petroleum Co.	Philube EP 1
Shell Oil Co.	Alvania EP Grease #1

* For northern climate applications. For continuous operation at constant ambient temperatures less than 0 °F or –18 °C (for example refrigeration systems), consult SKF.

Table 3

Coupling speed range		
Coupling size	Speed range with NLGI 1 grease*	
	Minimum	Allowed
r/min		
–	r/min	
1010	1 030	7 000
1015	700	6 000
1020	550	5 000
1025	460	4 750
1030	380	4 400
1035	330	3 900
1040	290	3 600
1045	250	3 200
1050	230	2 900
1055	210	2 650
1060	190	2 450
1070	160	2 150
1080	140	1 750
1090	120	1 550
1100	110	1 450
1100	100	1 330
1120	94	1 200
1130	88	1 075
1140	82	920
1150	76	770
1160	72	650
1180	64	480
1200	58	370
1220	52	290
1240	48	270
1260	44	250
1280	40	230
1300	38	220
2130	88	1 075
2140	82	920
2150	76	770
2160	72	650
2180	64	480
2200	58	370
2220	52	290
2240	48	270
2260	44	250
2280	40	230
2300	38	220

* Coupling speed range with NLGI 0 greases is from zero to the maximum shown.

Information shown for sizes 1010 through 1070 also applies to size 10 through 70 respectively, e.g. 1010 = 10, etc

Shaft alignment tools

TMEA series

Pinpoint accurate alignment simply achieved

The SKF shaft alignment tools, TMEA series, offer you simplicity with a high degree of accuracy.

Measuring, aligning and documenting

These highly innovative tools feature a three-step process for correcting alignment. First, measure the machinery's current alignment status. Then, align the machine vertically and horizontally. Finally, document and keep track of the alignment activities.

These three simple steps allow you to easily and effectively align shafts using advanced laser technology.

Features

- Easy-to-use, three-step process: measure-align-document
- Compact, lightweight design
- Spirit levels allow easy and fast positioning of the measuring units
- Measurements in millimeters or inches facilitate worldwide use
- Supplied in sturdy, lightweight carrying cases for portability
- Supplied with high precision SKF pre-cut shims for accurate alignment





TMEA 2

Easy, quick and affordable shaft alignment

The TMEA 2 is an easy-to-use shaft alignment tool, which requires no special training to operate.

The two measuring units can be easily attached to the shafts using magnetic brackets or chains.

Each measuring unit emits a laser line, which is projected on the detector of the other unit.

Features

- Display unit simultaneously provides clear “real-time” coupling and values in feet during alignment process making rechecking of the alignment unnecessary
- The laser and scale lines facilitate easy pre-alignment
- “Soft foot” feature easily guides the operator through this function
- Display unit can be held using one hand, freeing the operator to perform the alignment
- Magnetic brackets allow easy fixture of the measuring units onto the shaft
- A set of blank alignment reports to help you keep record of your alignment jobs
- Maximum distance of 0,85 m (2.8 ft) between the measuring unit’s brackets



TMEA 1P/2,5

Shaft alignment tool with printer capability. Record alignment activities using an optional printer

The TMEA 1P/2,5 offers you the advantage of keeping record of the alignment activities. It is equipped with a printer port to which the optional thermal printer TMEA P1 can be connected.

The printer provides a clear and complete alignment report, which can be used to document alignment activities. This user-friendly printer is operated with the touch of a single button on the display unit of the TMEA 1P/2,5.

Features

- Optional printer facilitates recording of alignment activities
- Maximum distance of 2,5 m (8,2 ft) between the measuring units makes it suitable for aligning a variety of applications
- Display unit provides clear “real-time” values during the alignment process making rechecking alignment unnecessary
- User-friendly display unit with only four buttons for operation
- Supplied with blank alignment reports for recording alignment activities in case the printer is not purchased



TMEA 1PEX

Accurate alignment in potentially explosive hazardous areas. Intrinsically safe shaft alignment tool

The TMEA 1PEX is an intrinsically safe (Ex) shaft alignment tool, especially designed for use in potentially explosive hazardous areas. It has been tested and certified according to the latest ATEX standards in intrinsic safety zones generally found in industries such as petrochemical, gas and pharmaceutical, among others. The TMEA 1PEX is supplied standard with a thermal printer for recording alignment activities.

Features

- Intrinsically safe classification ATEX code: II 2 G, EEx ib IIC T4, at ambient temperature range of 0 to 40 °C (32 to 104 °F) EC Type Examination Certificate Nemko 03ATEX101X
- Standard printer facilitates recording of alignment activities
- Maximum distance of 1 m (3 ft) between the measuring units makes it suitable for aligning a variety of applications
- Display unit provides clear “real-time” values during the alignment process making rechecking alignment unnecessary
- User-friendly display unit with only five buttons for operation



Thermal printer TMEA P1

Keep track of alignment jobs

This compact thermal printer helps you to document your alignment jobs. A clear and complete printout of the measurement data shows that the machine has been properly aligned within the allowed tolerances.

Features

- Compact easy-to-use printer
- Clear easy-to-read printout
- Pre-alignment and post-alignment reports possible
- Battery is rechargeable
- Continental European adaptor included
- Printer uses standard thermal paper roll, 120 mm x 20 m (4.4 in x 65 ft)
- Can be used in combination with TMEA 1P/2,5 and TMEA 1PEX only



Machinery shims TMAS series

For accurate vertical machinery alignment

Accurate machine adjustment is an essential element of any alignment process. SKF single slot pre-cut shims are available in five different dimensions and in ten different thicknesses.

Features

- Made of high quality stainless steel, allowing re-use
- Easy to fit and to remove
- Close tolerances for accurate alignment
- Thickness clearly marked on each shim
- Fully de-burred
- Pre-cut shims are supplied in packs of 10 and complete kits are also available

Table 1

Contents in TMAS shim kits

Designation	Size, mm	Thickness, mm									
		0,05	0,10	0,20	0,25	0,40	0,50	0,70	1,00	2,00	
		Quantities									
TMAS 340	100 × 100	20	20	20	20	20	20	20	20	10	
	125 × 125	20	20	20	20	20	20	20	20	10	
TMAS 360	50 × 50	20	20	20	–	–	20	–	20	20	
	75 × 75	20	20	20	–	–	20	–	20	20	
	100 × 100	20	20	20	–	–	20	–	20	20	
TMAS 510	50 × 50	20	20	20	20	20	20	20	20	10	
	75 × 75	20	20	20	20	20	20	20	20	10	
	100 × 100	20	20	20	20	20	20	20	20	10	
TMAS 720	50 × 50	20	20	20	20	20	20	20	20	20	
	75 × 75	20	20	20	20	20	20	20	20	20	
	100 × 100	20	20	20	20	20	20	20	20	20	
	125 × 125	20	20	20	20	20	20	20	20	20	

Inspection tool

Stroboscope TMRS 1

Easy, cost effective inspection in a flash

The SKF TMRS 1 is a portable, easy-to-use stroboscope that allows the motion of rotating or reciprocating machinery to appear frozen, facilitating inspection without stopping the machine. Equipped with a phase shift feature that allows the user to advance or retard the flash timing without changing the flash rate, the motion can be “frozen” at the position required for inspection.

Features

- The bright flash allows better illumination of the application at a distance, giving a wider viewing area.
- Flash rates of up to 12 500 flashes per minute (FPM) cover a wide range of applications
- Flash rate is quick and easy to adjust using the variable dial rate. Allows the required speed to be reached within a matter of seconds
- Phase shift mode for optimum inspection of gears, rolls, fans, pulleys. The feature of interest can be rotated to the correct position for inspection
- $\times 2$, $\div 2$ buttons for quick adjustment of FPM
- Easy to read LCD display
- Compact design, one-hand operated instrument
- Battery powered with long running time per charge (up to 2,5 h)
- Includes universal AC adaptor that can be used worldwide
- Extra flashtube supplied to minimise downtime of unit
- Supplied in carrying case for protection and portability
- Mounting thread on the underside allows mounting on a tripod for stability and ease of use



Table 1

Technical data	
Designation	TMRS 1
Flash rate range	12 500 flashes per minute (FPM)
Flash rate accuracy	$\pm 0,5$ FPM or $\pm 0,01\%$ of reading, whichever is greater
Flash setting resolution	to 9 999 FPM $-0,1$ FPM, 10 000 to 12 500 FPM -1 FPM
Tachometer range	40–59 000 r/min
Tachometer accuracy	$\pm 0,5$ r/min or $\pm 0,01\%$ of reading, whichever is greater
Flash tube	Xenon, 10 W, TMRS 1-BULB
Flash tube life	100 million flashes
Flash duration	9–15 msec
Light power	154 mJ per flash
Battery type	NiMH, rechargeable, removable
Battery capacity	2,6 AmpHr
Battery charge time	2–4 hours, using supplied AC adapter
Run time per charge	2,5 hours at 1 600 FPM, 1,25 hours at 3 200 FPM
Battery charger	AC input 100–240 VAC, 50/60 Hz
Display	8 character by 2 line LCD, alphanumeric
Display update	Continuous
Display resolution	100 to 9 999 FPM $-0,1$ FPM, 10 000 to 12 500 FPM -1 FPM
Time base	Crystal oscillator, 100 ppm accuracy
Controls	Power, $\times 2$, $\times 1/2$, phase shift, external trigger
External trigger input	0–5V TTL type via stereo phono jack
EXTL. trigger to flash delay	5 ms maximum
Clock output	0–5V TTL Type signal via stereo phono jack
Colour	Grey
Housing	Impact and oil resistant polycarbonate
Weight	650 g (1 lb, 4 oz)
Operating temperature	10 to 40 °C (50 to 104 °F)
Storage temperature	-20 to 45 °C (-4 to 113 °F)

SKF – the knowledge engineering company

From the company that invented the self-aligning ball bearing more than 100 years ago, SKF has evolved into a knowledge engineering company that is able to draw on five technology platforms to create unique solutions for its customers. These platforms include bearings, bearing units and seals, of course, but extend to other areas including: lubricants and lubrication systems, critical for long bearing life in many applications; mechatronics that combine mechanical and electronics knowledge into systems for more effective linear motion and sensorized solutions; and a full range of services, from design and logistics support to condition monitoring and reliability systems.

Though the scope has broadened, SKF continues to maintain the world's leadership in the design, manufacture and marketing of rolling bearings, as well as complementary products such as radial seals. SKF also holds an increasingly important position in the market for linear motion products, high-precision aerospace bearings, machine tool spindles and plant maintenance services.

The SKF Group is globally certified to ISO 14001, the international standard for environmental management, as well as OHSAS 18001, the health and safety management standard. Individual divisions have been approved for quality certification in accordance with ISO 9001 and other customer specific requirements.

With over 100 manufacturing sites worldwide and sales companies in 70 countries, SKF is a truly international corporation. In addition, our distributors and dealers in some 15 000 locations around the world, an e-business marketplace and a global distribution system put SKF close to customers for the supply of both products and services. In essence, SKF solutions are available wherever and whenever customers need them. Overall, the SKF brand and the corporation are stronger than ever. As the knowledge engineering company, we stand ready to serve you with world-class product competencies, intellectual resources, and the vision to help you succeed.



© Airbus – photo: e²m company, H. Goussé

Evolving by-wire technology

SKF has a unique expertise in the fast-growing by-wire technology, from fly-by-wire, to drive-by-wire, to work-by-wire. SKF pioneered practical fly-by-wire technology and is a close working partner with all aerospace industry leaders. As an example, virtually all aircraft of the Airbus design use SKF by-wire systems for cockpit flight control.

SKF is also a leader in automotive by-wire technology, and has partnered with automotive engineers to develop two concept cars, which employ SKF mechatronics for steering and braking. Further by-wire development has led SKF to produce an all-electric forklift truck, which uses mechatronics rather than hydraulics for all controls.

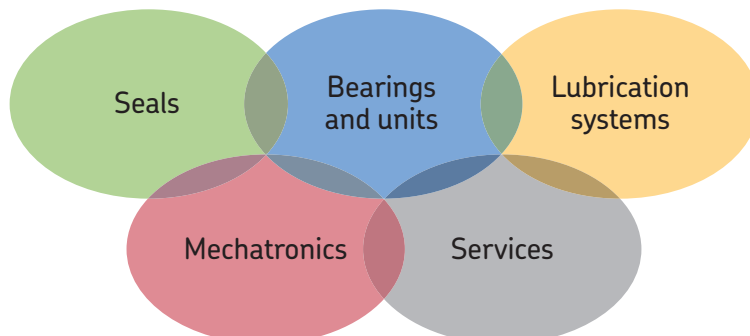



Harnessing wind power

The growing industry of wind-generated electric power provides a source of clean, green electricity. SKF is working closely with global industry leaders to develop efficient and trouble-free turbines, providing a wide range of large, highly specialized bearings and condition monitoring systems to extend equipment life of wind farms located in even the most remote and inhospitable environments.



Working in extreme environments

In frigid winters, especially in northern countries, extreme sub-zero temperatures can cause bearings in railway axleboxes to seize due to lubrication starvation. SKF created a new family of synthetic lubricants formulated to retain their lubrication viscosity even at these extreme temperatures. SKF knowledge enables manufacturers and end user customers to overcome the performance issues resulting from extreme temperatures, whether hot or cold. For example, SKF products are at work in diverse environments such as baking ovens and instant freezing in food processing plants.



Developing a cleaner cleaner

The electric motor and its bearings are the heart of many household appliances. SKF works closely with appliance manufacturers to improve their products' performance, cut costs, reduce weight, and reduce energy consumption. A recent example of this cooperation is a new generation of vacuum cleaners with substantially more suction. SKF knowledge in the area of small bearing technology is also applied to manufacturers of power tools and office equipment.



Maintaining a 350 km/h R&D lab

In addition to SKF's renowned research and development facilities in Europe and the United States, Formula One car racing provides a unique environment for SKF to push the limits of bearing technology. For over 60 years, SKF products, engineering and knowledge have helped make Scuderia Ferrari a formidable force in F1 racing. (The average racing Ferrari utilizes around 150 SKF components.) Lessons learned here are applied to the products we provide to automakers and the aftermarket worldwide.



Delivering Asset Efficiency Optimization

Through SKF Reliability Systems, SKF provides a comprehensive range of asset efficiency products and services, from condition monitoring hardware and software to maintenance strategies, engineering assistance and machine reliability programmes. To optimize efficiency and boost productivity, some industrial facilities opt for an Integrated Maintenance Solution, in which SKF delivers all services under one fixed-fee, performance-based contract.



Planning for sustainable growth

By their very nature, bearings make a positive contribution to the natural environment, enabling machinery to operate more efficiently, consume less power, and require less lubrication. By raising the performance bar for our own products, SKF is enabling a new generation of high-efficiency products and equipment. With an eye to the future and the world we will leave to our children, the SKF Group policy on environment, health and safety, as well as the manufacturing techniques, are planned and implemented to help protect and preserve the earth's limited natural resources. We remain committed to sustainable, environmentally responsible growth.

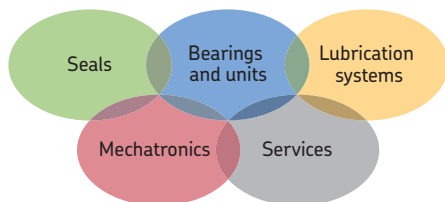

The Power of Knowledge Engineering

Drawing on five areas of competence and application-specific expertise amassed over more than 100 years, SKF brings innovative solutions to OEMs and production facilities in every major industry worldwide. These five competence areas include bearings and units, seals, lubrication systems, mechatronics (combining mechanics and electronics into intelligent systems), and a wide range of services, from 3-D computer modelling to advanced condition monitoring and reliability and asset management systems. A global presence provides SKF customers uniform quality standards and worldwide product availability.

© SKF is a registered trademark of the SKF Group. Hytrel is a registered trademark of DuPont.

© SKF Group 2010

The contents of this publication are the copyright of the publisher and may not be reproduced (even extracts) unless prior written permission is granted. Every care has been taken to ensure the accuracy of the information contained in this publication but no liability can be accepted for any loss or damage whether direct, indirect or consequential arising out of the use of the information contained herein.

PUB PT/P2 06897 EN · May 2010

Printed in Germany on environmentally friendly paper.

