

# SKF Conveyor Chains





# Contents

## 1 Introduction

Introduction .....	2
General guidelines for selecting conveyor chains .....	4
SKF – the knowledge engineering company .....	6

## 2 Product data

<b>Principles of conveyor chains .....</b>	<b>9</b>
M Series .....	10
Z Series .....	15
FV Series .....	20
W Series (Welded steel mill and drag chains) .....	25
C Series .....	31
Lumber mill series .....	38
Steel pintle series .....	39
Steel mill series .....	44
Scraper series .....	51
Crawler asphalt paver series .....	55
Top chain curve movement series .....	57
Double flex series .....	59
Universal movement series .....	61
Escalator step series .....	63
Rice harvester series .....	66
Double plus series .....	72
Crank link drive series .....	74
2184 Series .....	75
9060 Series .....	76
Elevator series .....	77
Hoisting series .....	78
Roller chain with vulcanised elastomer .....	80
Steel agricultural series .....	86
Sharp top series .....	89
Hollow pin series .....	99
Engineering bush series .....	104
Combination series .....	108
H class mill series .....	112
Rivetless series .....	114
Barloop series .....	115
900 class pintle series .....	116
400 class pintle series – cast steel .....	117
700 class pintle series – cast steel .....	120
Detachable series .....	123
H class transfer (roof top) series .....	126
Combination transfer (roof top) series .....	127

## 3 Additional information

Conveyor chains – basic maintenance notes .....	128
---	-----



# Introduction

The SKF brand now stands for more than ever before, and means more to you as a valued customer.

While SKF maintains its leadership as a high-quality bearing manufacturer throughout the world, new dimensions in technical advances, product support and services have evolved SKF into a truly solutions-oriented supplier, creating greater value for customers.

These solutions enable customers to improve productivity, not only with breakthrough application-specific products, but also through leading-edge design simulation tools and consultancy services, plant asset efficiency maintenance programmes, and the industry's most advanced supply management techniques.

The SKF brand still stands for the very best in rolling bearings, but it now stands for much more.

**SKF – the knowledge engineering company**

Conveyor chains, whether they are roller or cast in construction, are found today in virtually every industry.

Unlike other types of chains that transfer power from one shaft to another, the conveyor chain is used to pull (or elevate) a load, usually in a straight line, at relatively slow speeds. As a result, the conveyor chain is rated in terms of their allowable working loads and not by power or speed.

For all the different types of conveyors and chain applications, there is an equally large number of chain configurations and materials available.

The SKF range of conveyor chains covers a wide variety of chains and chain materials.

## Industry types

Typical industries covered include:

- Sugar
- Cement
- Steel
- Lumber
- Waste water
- Mining
- Power / Energy
- Converting
- Food & Beverage
- Pulp & Paper
- Palm Oil
- Agriculture
- Refuse / Recycling
- Construction
- Leisure (Theme park)
- Automotive (Assembly)
- Meat / Poultry
- Horticulture

## Range

This catalogue is intended to make chain selection as simple as possible. It includes standard as well as alternative chains with pitches ranging from 12.7 to 1,000 mm. Tensile strengths range from Ultimate (UTS) to 900 kN. With modification, higher tensile strengths are possible.

The Long Pitch (LP) roller chains in this catalogue are in accordance with DIN 8187, ISO 1977 and BS 4116 (Part IV), covering series M, MC, FV and Z series, in metric and inch sizes.

Various roller or bush chain options are also available including:

- Welded (Mill and Drag) chains
- Cast combination chains
- Pintle (400, 700 and 900 class) chains
- Rivet-less and barloop chains
- Rice chains
- Elevator and escalator chains
- Rooftop / transfer chains
- Detachable chains
- Side-flexing chains.

## Selection

When selecting a conveyor chain for a specific application, many aspects of the conveyor system have to be considered. There are no general rules that cover all types of chains (long pitch, roller, bush, steel, cast etc.), even though the selection procedures are similar.

Typically aspects that need to be considered are:

- Working load (chain pull),
- Chain speed
- Pitch requirement (particularly important for attachment chains such as elevators)
- Type and spacing of attachment (if any)
- Chain length (centres), or lengths for multi-strand applications
- Lubrication (type and method of application)
- Environmental issues (such as dirt, temperature extremes, chemicals, contamination, hygiene requirements etc.)
- Available space
- Required chain through-life

To improve through-life, SKF, in consultation with factory engineers, can offer a number of options that will not only increase chain



strength, but improve wear resistance of the chain, and sprockets.

Options include but are not limited to alternative materials, selective heat treatment of particular components such as side bars (wear faces), pins, bushes (barrels) and / or rollers.

When optimising conveyor chains, there is usually a compromise between strength and wear resistance, to obtain the required through-life in a cost-effective way.

## Materials

The use of different grades and hardness of steel to manufacture various chain components provide the best combinations to increase strength and improve wear resistance. Low to medium carbon and alloy steels, in conjunction with various heat treatment methods, result in good mechanical properties, wear resistance and hardness.

SKF conveyor chains are made from alloy steels or cast iron depending on the chain series and type. Stainless steel is also available for corrosive environments or applications where there are frequent wash-downs e.g. food, beverage and pharmaceutical applications.



The correct material and hardness of pins, bushings, rollers and side bars provide high quality, long lasting chains.

## Heat treatment

SKF chain components undergo different heat treatment processes depending on the component and material grade.

The most common heat treatment processes used during the manufacturing process are:

- **Through hardening** – when using medium carbon steel. All steel parts are treated throughout to increase the chains' component strength and improve wear resistance.
- **Carburizing** – the heat process used to increase the wear resistance of chain components (and some sprockets), to obtain a high surface hardness, depending on the steel type used.
- **Induction hardening** – To use this process of heat treatment, the chain parts are induction hardened to obtain a controlled hardness depth, while still maintaining a ductile core. The induction hardening process produces a surface much harder than those treated with the through hardening treatment.
- **Selective induction hardening** – This treatment is similar to the preceding treatment, but only in selective areas, allowing the other areas of the chain component to be ductile. This is the most usable hardening treatment used for the chain pins (as the pin is often exposed to extreme shock loads), and on the wearing surfaces of chain sidebars being exposed to sliding wear.
- **Other** – Some conveyor chain applications require special surface protection e.g. zinc hot dip or electrolytic galvanizing.

All SKF Conveyor Chains are manufactured to extremely close tolerances, and use high quality material combinations, to provide

long service life, excellent plate / pin / bush integrity and uniform pitch lengths.

## Packaging

Where practical, all chains are packaged (boxed or palletised) for safe handling. Containers are clearly marked to customer specifications

They are also available in the SKF transmission chain catalogue (SKF publication 6772 EN), covering all DIN/BS, ANSI transmission type chains, attachments, drive chains, SLR lubrication-free chains, stainless chains, heavy duty chains, silent and PIV type chains...

# General guidelines for selecting conveyor chains

When selecting conveyor chains for a particular application, there are a number of factors that should be considered. These include, but are not limited to, the following:

- Working load (chain pull)
- Chain speed
- Pitch requirement (particularly important for attachment chains such as elevators)
- Type and spacing of attachment (if any)
- Chain length (centres), or lengths for multi-strand applications
- Lubrication (type and method of application)
- Environmental issues (such as dirt, temperature extremes, chemicals, contamination, hygiene requirements etc.)
- Available space
- Required chain 'through-life'

## (i) Working load ( $F_R$ ) (kN)

The working load summation ( $\Sigma W$ ):

- the load on the chain (or chains) from the product / process
- the selected chain total weight, with attachments etc., if applicable
- any external influences (e.g. tripper / loading forces)
- Angle of inclination ( $\alpha$ ) or decline (Note: In the case of decline conveyors the loading value may have a negative (-ve) or 'regenerative' effect on the total chain pull summation)
- Friction influences:
  - Rolling friction (e.g. where chain rollers are proud of the sidebar)
  - Sliding friction (e.g. where the side bars are sliding on the base), which will also be influenced by
    - Sliding on bare steel
    - Sliding on plastic (e.g. UHWPE), hardwood or other material
  - Lubrication factor (i.e. lubricated or, no lubrication)

If the conveyor system involves more than one chain (e.g. dual, triple or more strands), the loads are usually split over the number

of chains, i.e. 1/2 or 1/3 of the  $F_R$  (see (v) below)

## (ii) Chain speed ( $v$ ) (m/s)

Chain speed is generally determined by the application. There are, however, general guidelines for the maximum recommended speed for chains, particularly for cast chains. These should be referred to in the respective industry catalogues.

## (iii) Safety factors ( $F_S$ )

Most conveyor chain catalogues list only an ultimate or average tensile strength in kilonewtons (kN), kgf or lbf. These figures are determined by failure testing, statistical analysis and / or compliance with minimum standards (such as ANSI / DIN / BS etc.), where applicable.

The chain should be selected to operate well within safety guidelines. The safety factor will be determined by a number of influences.

- type of chain (e.g. cast or steel). (Cast chains generally operate at slower speeds and lower tensile loads)
- Loading conditions – typically uniform (U), moderate (M) or heavy (H)
- Chain speed ( $v$ )
- Temperature / ambient factors ( $F_T$ )

These  $F_S$  factors can vary from 6.5:1 for slow speed, uniform load applications to 22:1, for applications where there are higher speeds or shock loads.

Additionally, it should be noted that some industries have established, through their specific requirements and uniqueness, minimum standards and safety factors.

## (iv) Sprockets

The size (number of teeth) on the sprockets, whether driver, or idler (non-drive, idler, bend etc.), will generally be determined by necessity (such as space restrictions).

In any case, the drive sprocket should be as large as possible, to provide smooth transition of the chain(s) on and off the sprocket / chain wheel, and to eliminate any "chordal effect" or 'hunting' (which is common on small tooth sprockets, where the chain 'staggers', as a result of the chain lifting up in the sprocket, due to an inability to sit correctly).

Smaller pitch chains, operating on larger sprockets generally provide better chain articulation than a larger pitch chain, but this is not always feasible. Larger sprocket sizes will also be beneficial on the drive system, with lower overhung loads on the respective shafts and bearings.

Odd numbers of teeth generally offer a better wear rate, due to the 'hunting' of the chain over different teeth during each mesh.

## (v) Other factors

- **Attachments.** The spacing of the attachments may have an influence on the final chain pitch. The lower the pitch, the higher the number of bushes, pins and (if applicable) rollers, and hence generally a higher relative cost is typical for chains of similar load capacity.

Additionally if the attachments are subject to high load forces (e.g. during a process), these forces need to be taken into account when considering the chain load conditions. Refer to (a) above.

- **Material enhancements.** The range of chains offered are often available in different materials (e.g. stainless steel), and it is important the strength values for the chain material selected is used. This may also be applicable to some treatment processes.

- **Temperature (elevated) ( $F_T$ ).** Where there are high ambient temperatures the load carrying capacity of the chain should be reduced, especially if temperatures exceed  $160^\circ\text{C}$  ( $320^\circ\text{F}$ ). If temperatures are particularly high, special materials may have to be considered.

For low temperature ( $< \text{minus } 20^\circ\text{C}$ ) applications, which typically have to contend with condensation and water, special materials e.g. stainless steel, may have to be considered.

- **Multiple stands ( $S_n$ ).** One way of reducing chain size is using multiple strands. Multiple strands are common where an attachment links two or more strands to carry a product).

In these cases, the chain strands should be 'matched' at the factory to be sure they run true with each other. This should be stated at the time of order. The chains are then 'tagged' accordingly.

Note: - Matched chains usually incur a factory surcharge.

- **Lubrication.** The type of lubricant (e.g. mineral, vegetable (food-grade) soap-water) is generally determined by the application and its operating conditions. The point of application is usually within the pin / bush / roller area.

The method used to apply the lubricant to the chain can have a substantial effect on chain through-life.

SKF lubrication systems can offer complete lubrication solutions, for the continual supply of lubricant to the articulating points of a chain, with various metered options.

Additionally, it should be noted that, if for some reason, a chain cannot be lubricated, the selection parameters must take this into account. The reason being, the resultant loading will be significantly higher, as will the wear-rate of the chain, which will have a significant effect on the through-life of both the chain and sprockets.

# SKF – the knowledge engineering company

From the company that invented the self-aligning ball bearing more than 100 years ago, SKF has evolved into a knowledge engineering company that is able to draw on five technology platforms to create unique solutions for its customers. These platforms include bearings, bearing units and seals, of course, but extend to other areas including: lubricants and lubrication systems, critical for long bearing life in many applications; mechatronics that combine mechanical and electronics knowledge into systems for more effective linear motion and sensorized solutions; and a full range of services, from design and logistics support to condition monitoring and reliability systems.

Though the scope has broadened, SKF continues to maintain the world's leadership in the design, manufacture and marketing of rolling bearings, as well as complementary products such as radial seals. SKF also holds an increasingly important position in the market for linear motion products, high-precision aerospace bearings, machine tool spindles and plant maintenance services.

The SKF Group is globally certified to ISO 14001, the international standard for environmental management, as well as OHSAS 18001, the health and safety management standard. Individual divisions have been approved for quality certification in accordance with ISO 9001 and other customer specific requirements.

With over 120 manufacturing sites worldwide and sales companies in 70 countries, SKF is a truly international corporation. In addition, our distributors and dealers in some 15 000 locations around the world, an e-business marketplace and a global distribution system put SKF close to customers for the supply of both products and services. In essence, SKF solutions are available wherever and whenever customers need them. Overall, the SKF brand and the corporation are stronger than ever. As the knowledge engineering company, we stand ready to serve you with world-class product competencies, intellectual resources, and the vision to help you succeed.



© Airbus – photo: e\*im company, H. Goussé

## ***Evolving by-wire technology***

*SKF has a unique expertise in the fast-growing by-wire technology, from fly-by-wire, to drive-by-wire, to work-by-wire. SKF pioneered practical fly-by-wire technology and is a close working partner with all aerospace industry leaders. As an example, virtually all aircraft of the Airbus design use SKF by-wire systems for cockpit flight control.*

*SKF is also a leader in automotive by-wire technology, and has partnered with automotive engineers to develop two concept cars, which employ SKF mechatronics for steering and braking. Further by-wire development has led SKF to produce an all-electric forklift truck, which uses mechatronics rather than hydraulics for all controls.*

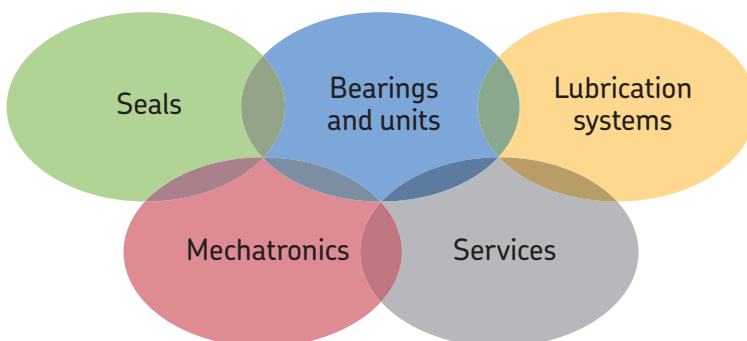



**Harnessing wind power**

The growing industry of wind-generated electric power provides a source of clean, green electricity. SKF is working closely with global industry leaders to develop efficient and trouble-free turbines, providing a wide range of large, highly specialized bearings and condition monitoring systems to extend equipment life of wind farms located in even the most remote and inhospitable environments.



**Working in extreme environments**

In frigid winters, especially in northern countries, extreme sub-zero temperatures can cause bearings in railway axleboxes to seize due to lubrication starvation. SKF created a new family of synthetic lubricants formulated to retain their lubrication viscosity even at these extreme temperatures. SKF knowledge enables manufacturers and end user customers to overcome the performance issues resulting from extreme temperatures, whether hot or cold. For example, SKF products are at work in diverse environments such as baking ovens and instant freezing in food processing plants.



**Developing a cleaner cleaner**

The electric motor and its bearings are the heart of many household appliances. SKF works closely with appliance manufacturers to improve their products' performance, cut costs, reduce weight, and reduce energy consumption. A recent example of this cooperation is a new generation of vacuum cleaners with substantially more suction. SKF knowledge in the area of small bearing technology is also applied to manufacturers of power tools and office equipment.



**Maintaining a 350 km/h R&D lab**

In addition to SKF's renowned research and development facilities in Europe and the United States, Formula One car racing provides a unique environment for SKF to push the limits of bearing technology. For over 60 years, SKF products, engineering and knowledge have helped make Scuderia Ferrari a formidable force in F1 racing. (The average racing Ferrari utilizes around 150 SKF components.) Lessons learned here are applied to the products we provide to automakers and the aftermarket worldwide.



**Delivering Asset Efficiency Optimization**

Through SKF Reliability Systems, SKF provides a comprehensive range of asset efficiency products and services, from condition monitoring hardware and software to maintenance strategies, engineering assistance and machine reliability programmes. To optimize efficiency and boost productivity, some industrial facilities opt for an Integrated Maintenance Solution, in which SKF delivers all services under one fixed-fee, performance-based contract.



**Planning for sustainable growth**

By their very nature, bearings make a positive contribution to the natural environment, enabling machinery to operate more efficiently, consume less power, and require less lubrication. By raising the performance bar for our own products, SKF is enabling a new generation of high-efficiency products and equipment. With an eye to the future and the world we will leave to our children, the SKF Group policy on environment, health and safety, as well as the manufacturing techniques, are planned and implemented to help protect and preserve the earth's limited natural resources. We remain committed to sustainable, environmentally responsible growth.







**M Series**  
M - Series

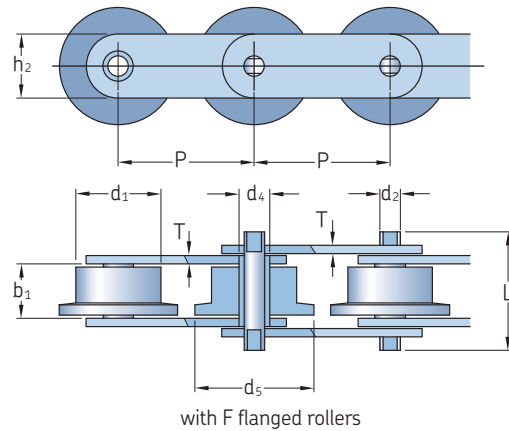
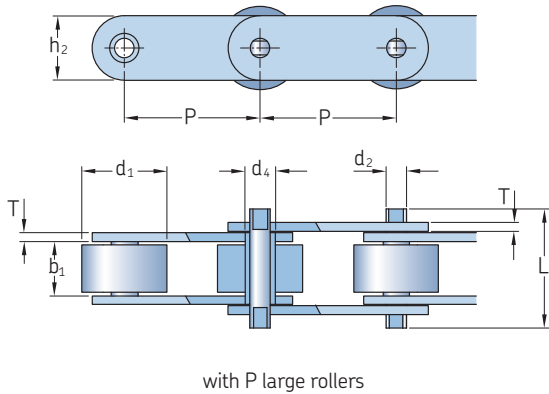
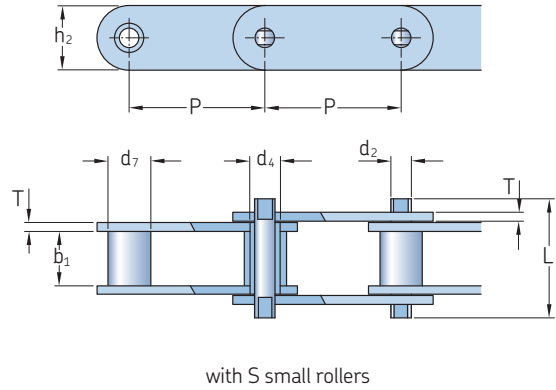
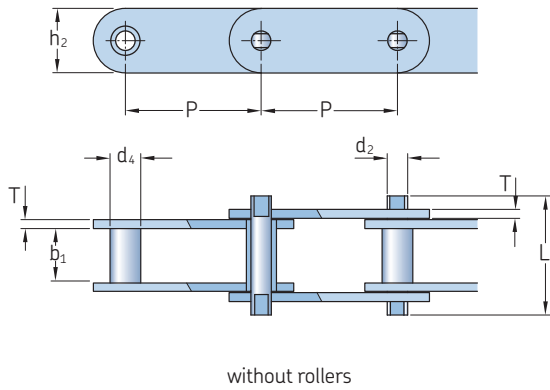

Chain number	Pitch sizes available							
	P							
-	mm							
M20A	40*	50	63	80	100	125	160	-
M28A	50*	63	80	100	125	160	200	-
M40A	63	80	100	125	160	200	250	-
M56A	63*	80	100	125	160	200	250	-
M80A	80	100	125	160	200	250	315	-
M112A	80*	100	125	160	200	250	315	400
M160A	100*	125	160	200	250	315	400	500
M224A	125*	160	200	250	315	400	500	630
M315A	160*	200	250	315	400	500	630	-
M450A	200	250	315	400	500	630	800	-
M650A	250	315	400	500	630	800	1 000	-
M900A	250	315	400	500	630	800	1 000	-

Chain number	Dimensions							Pin length	Plate height	Plate thickness	Ultimate tensile strength Q	Average tensile strength Q <sub>0</sub>	Designation
	Roller diameter		Bush diameter	Width between inner plates	Pin diameter	Pin length	Plate height						
	d <sub>1</sub> Max.	d <sub>7</sub> Max.						d <sub>5</sub> Max.	d <sub>4</sub> Max.	b <sub>1</sub> Min.	d <sub>2</sub> Max.	L Max.	h <sub>2</sub> Max.
-	mm											kN	-
M20A	25	13	32	9	16	6	35	19	2,5	20	25,0	PHC M20A...	
M28A	30	15	36	10	18	7	40	21	3,0	28	35,0	PHC M28A...	
M40A	36	18	42	13	20	9	45	26	3,5	40	50,0	PHC M40A...	
M56A	42	21	50	15	24	10	52	31	4,0	56	70,0	PHC M56A...	
M80A	50	25	60	18	28	12	62	36	5,0	80	100,0	PHC M80A...	
M112A	60	30	70	21	32	15	73	41	6,0	112	140,0	PHC M112A...	
M160A	70	36	85	25	37	18	85	51	7,0	160	200,0	PHC M160A...	
M224A	85	42	100	30	43	21	98	62	8,0	224	280,0	PHC M224A...	
M315A	100	50	120	36	48	25	112	72	10,0	315	393,7	PHC M315A...	
M450A	120	60	140	42	56	30	135	82	12,0	450	562,5	PHC M450A...	
M650A	140	70	175	50	65	36	154	103	14,0	650	715,0	PHC M650A...	
M900A	170	85	210	60	76	44	180	123	16,0	900	990,0	PHC M900A...	

\* Only available with small roller or without roller  
Standard lengths are 10 ft. and 5 m. To complete designation add pitch size and chain length. For example, to order M20A with 40 mm pitch without roller in 10 ft. length, use designation PHC M20A-40X10FT. For ordering a special roller type add letter after pitch size (S for small roller, P for large roller and F for flanged roller). For example, to order M20A with 40 mm pitch with small roller in 10 ft length, use designation PHC M20A40SX10FT.



**M Series**  
MC - Series hollow pin

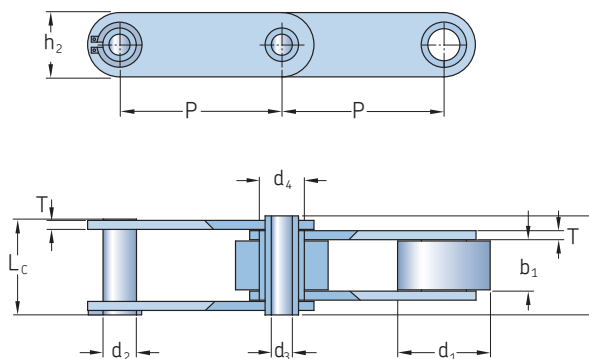

MC Series

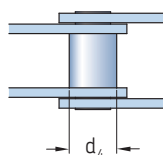

without rollers

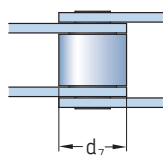

with S small rollers

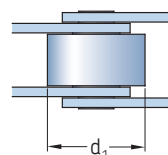

with P large rollers

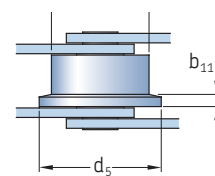

with F flanged rollers

Chain number	Pitch sizes available P						
-	mm						
MC28	63	80	100	125	160	-	-
MC56	80	100	125	160	200	250	315
MC112	100	125	160	200	250	315	500
MC224	160	200	250	315	400	500	-
MC28XT	63	80	100	125	160	-	-
MC56XT	80	100	125	160	200	250	315
MC112XT	100	125	160	200	250	315	500
MC224XT	160	200	250	315	400	500	-

Type	Chain number	Dimensions Roller diameter				Bush diameter d <sub>4</sub> Max.	Width between inner plates b <sub>1</sub> Min.	Pin diameter		Pin length		Plate height h <sub>2</sub> Max.	Plate thickness T Max.	Ultimate tensile strength Q Min.	Designation
		d <sub>1</sub> Max.	d <sub>7</sub> Max.	d <sub>5</sub> Max.	b <sub>11</sub>			d <sub>2</sub> Max.	d <sub>3</sub> Min.	L Max.	L <sub>c</sub> Max.				
-	-	mm											kN	-	
MC	MC28	36	25	45	4,5	17,5	20	13,0	8,2	36,0	38,5	25	3,5	28	PHC MC28...
	MC56	50	30	60	5,0	21,0	24	15,5	10,2	45,0	47,5	35	4,0	56	PHC MC56...
	MC112	70	42	85	7,0	29,0	32	22,0	14,3	62,5	64,3	50	6,0	112	PHC MC112...
	MC224	100	60	120	10,0	41,0	43	31,0	20,3	83,0	85,5	70	8,0	224	PHC MC224...
MC Xtra	MC28XT	36	25	45	4,5	17,5	20	13,0	8,2	36,0	38,5	25	3,5	40	PHC MC28XT...
	MC56XT	50	30	60	5,0	21,0	24	15,5	10,2	45,0	47,5	35	4,0	90	PHC MC56XT...
	MC112XT	70	42	85	7,0	29,0	32	22,0	14,3	62,5	64,3	50	6,0	180	PHC MC112XT...
	MC224XT	100	60	120	10,0	41,0	43	31,0	20,3	83,0	85,5	70	8,0	350	PHC MC224XT...

Standard lengths are 10 ft and 5 m. To complete designation add pitch size and chain length. For example, to order MC28 with 63 mm pitch without roller in 10 ft length, use designation PHC MC28-63X10FT. For ordering a special roller type add letter after pitch size (S for small roller, P for large roller and F for flanged roller). For example, to order MC28 with 63 mm pitch with small roller in 10 ft length, use designation PHC MC28-63SX10FT.

**M series**  
MT - Series deep link

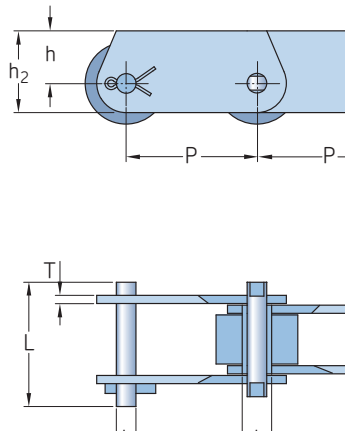

Chain number	Pitch sizes available				
	P				
–	mm				
MT20	40	50	63	80	100
MT28	50	63	80	100	125
MT40	63	80	100	125	160
MT56	63	80	100	125	160
MT80	80	100	125	160	200
MT112	80	100	125	160	200
MT160	100	125	160	200	250
MT224	125	160	200	250	315
MT315	160	200	250	315	400
MT450	200	250	315	400	500
MT650	250	315	400	500	630
MT900	250	315	400	500	630
MT20XT	40	50	63	80	100
MT28XT	50	63	80	100	125
MT40XT	63	80	100	125	160
MT56XT	63	80	100	125	160
MT80XT	80	100	125	160	200
MT112XT	80	100	125	160	200
MT160XT	100	125	160	200	250
MT224XT	125	160	200	250	315
MT315XT	160	200	250	315	400
MT450XT	200	250	315	400	500
MT650XT	250	315	400	500	630
MT900XT	250	315	400	500	630

Type	Chain number	Dimensions					Pin length	Plate height		Plate thickness	Ultimate tensile strength Q	Designation
		Roller diameter	Bush diameter	Width between inner plates	Pin diameter	Pin length		h <sub>2</sub>	h			
		d <sub>1</sub> Max.	d <sub>3</sub> Max.	b <sub>1</sub> Min.	d <sub>2</sub> Max.	L Max.	h <sub>2</sub> Max.	h Max.	T Max.	Min.	kN	–
–	–	mm										–
MT	MT20	25	9	16	6,0	35	25	16,0	2,5	20	PHC MT20...	
	MT28	30	10	18	7,0	40	30	20,0	3,0	28	PHC MT28...	
	MT40	36	13	20	8,5	45	35	22,5	3,5	40	PHC MT40...	
	MT56	42	15	24	10,0	52	45	30,0	4,0	56	PHC MT56...	
	MT80	50	18	28	12,0	62	50	32,5	5,0	80	PHC MT80...	
	MT112	60	21	32	15,0	73	60	40,0	6,0	112	PHC MT112...	
	MT160	70	25	37	18,0	85	70	45,0	7,0	160	PHC MT160...	
	MT224	85	30	43	21,0	98	90	60,0	8,0	224	PHC MT224...	
	MT315	100	36	48	25,0	112	100	65,0	10,0	315	PHC MT315...	
	MT450	120	42	56	30,0	135	120	80,0	12,0	450	PHC MT450...	
MT650	140	50	65	36,0	154	140	90,0	14,0	650	PHC MT650...		
MT900	170	60	76	44,0	180	180	120,0	16,0	900	PHC MT900...		
MT Xtra	MT20XT	25	9	16	6,0	35	25	16,0	2,5	32	PHC MT20XT...	
	MT28XT	30	10	18	7,0	40	30	20,0	3,0	42	PHC MT28XT...	
	MT40XT	36	13	20	8,5	45	35	22,5	3,5	60	PHC MT40XT...	
	MT56XT	42	15	24	10,0	52	45	30,0	4,0	85	PHC MT56XT...	
	MT80XT	50	18	28	12,0	62	50	32,5	5,0	125	PHC MT80XT...	
	MT112XT	60	21	32	15,0	73	60	40,0	6,0	175	PHC MT112XT...	
	MT160XT	70	25	37	18,0	85	70	45,0	7,0	260	PHC MT160XT...	
	MT224XT	85	30	43	21,0	98	90	60,0	8,0	340	PHC MT224XT...	
	MT315XT	100	36	48	25,0	112	100	65,0	10,0	520	PHC MT315XT...	
	MT450XT	120	42	56	30,0	135	120	80,0	12,0	700	PHC MT450XT...	
MT650XT	140	50	65	36,0	154	140	90,0	14,0	715	PHC MT650XT...		
MT900XT	170	60	76	44,0	180	180	120,0	16,0	990	PHC MT900XT...		

Standard lengths are 10 ft and 5 m. To complete designation add pitch size and chain length. For example, to order MT20 with 40 mm pitch in 10 ft length, use designation PHC MT20-40X10FT.

## M Series attachments

### K-2, A-2 attachments

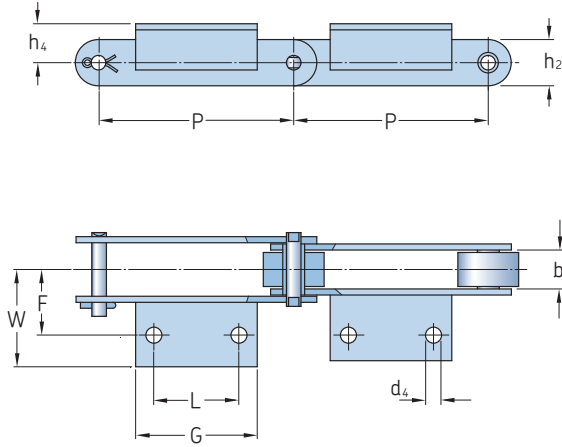

A-2

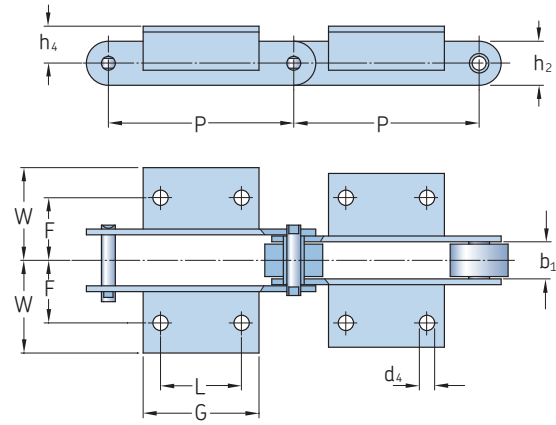

K-2

Chain number	Dimensions								Designation
	Pitch								
	P	L	G	d <sub>4</sub>	F	W	h <sub>4</sub>		
	mm								
M20A63	63	20	35	7	27	40	16	PHC M20A63...	
M20A80	80	35	50	7	27	40	16	PHC M20A80...	
M28A80	80	25	45	9	32	47	20	PHC M28A80...	
M28A100	100	40	60	9	32	47	20	PHC M28A100...	
M40A80	80	20	45	9	35	50	25	PHC M40A80...	
M40A100	100	40	60	9	35	50	25	PHC M40A100...	
M40A125	125	65	85	9	35	50	25	PHC M40A125...	
M56A100	100	25	50	11	44	61	30	PHC M56A100...	
M56A125	125	50	75	11	44	61	30	PHC M56A125...	
M56A160	160	85	110	11	44	61	30	PHC M56A160...	
M80A100	100	25	50	11	48	65	35	PHC M80A100...	
M80A125	125	50	75	11	48	65	35	PHC M80A125...	
M80A160	160	85	110	11	48	65	35	PHC M80A160...	
M80A200	200	125	150	11	48	65	35	PHC M80A200...	
M112A125	125	35	65	14	55	80	40	PHC M112A125...	
M112A160	160	65	95	14	55	80	40	PHC M112A160...	
M112A200	200	100	130	14	55	80	40	PHC M112A200...	
M160A125	125	25	50	14	62	85	45	PHC M160A125...	
M160A160	160	50	80	14	62	85	45	PHC M160A160...	
M160A200	200	85	115	14	62	85	45	PHC M160A200...	
M160A250	250	145	175	14	62	85	45	PHC M160A250...	
M224A200	200	65	100	18	70	110	55	PHC M224A200...	
M224A250	250	125	160	18	70	110	55	PHC M224A250...	
M224A315	315	190	230	18	70	110	55	PHC M224A315...	
M315A200	200	50	85	18	80	115	65	PHC M315A200...	
M315A250	250	100	140	18	80	115	65	PHC M315A250...	
M315A315	315	155	190	18	80	115	65	PHC M315A315...	
M315A400	400	155	205	18	80	115	65	PHC M315A400...	
M450A250	250	85	125	18	90	140	75	PHC M450A250...	
M450A315	315	155	195	18	90	140	75	PHC M450A315...	
M450A400	400	240	280	18	90	140	75	PHC M450A400...	
M450A500	500	240	280	18	90	140	75	PHC M450A500...	
M450A630	630	240	280	18	90	140	75	PHC M450A630...	
M650A315	315	100	150	24	115	190	90	PHC M650A315...	
M650A400	400	180	240	24	115	190	90	PHC M650A400...	
M650A500	500	300	350	24	115	190	90	PHC M650A500...	
M650A630	630	300	350	24	115	190	90	PHC M650A630...	
M900A315	315	65	125	30	140	240	110	PHC M900A315...	
M900A400	400	155	215	30	140	240	110	PHC M900A400...	
M900A500	500	240	300	30	140	240	110	PHC M900A500...	
M900A630	630	240	300	30	140	240	110	PHC M900A630...	

Standard lengths are 10 ft and 5 m. To complete designation add pitch size and chain length. For example, to order MC28 with 63 mm pitch without roller in 10 ft length, use designation PHC MC28-63X10FT. For ordering a special roller type add letter after pitch size (S for small roller, P for large roller and F for flanged roller). For example, to order MC28 with 63 mm pitch with small roller in 10 ft length, use designation PHC MC28-63SX10FT.

## M Series attachments

### K-1, A-1 attachments

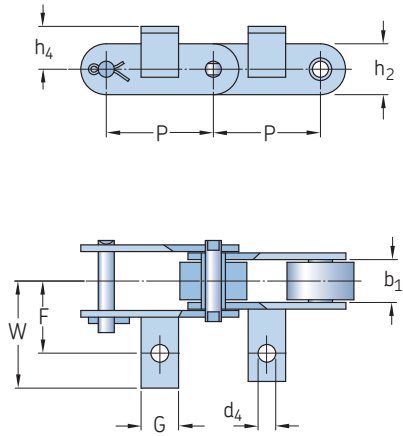

A-1

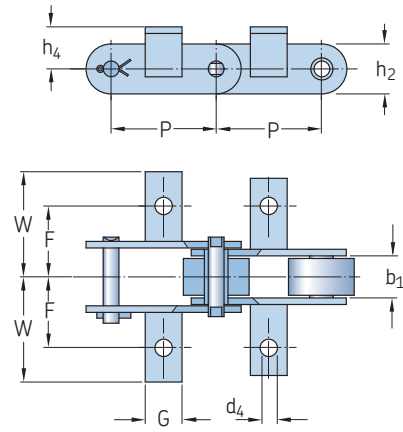

K-1

Chain number	Dimensions						Designation
	Pitch						
	P	G	d <sub>4</sub>	F	W	h <sub>4</sub>	
	mm						
M20A40	40	14	7	27	40	16	PHC M20A40...
M20A50	50	14	7	27	40	16	PHC M20A50...
M28A50	50	20	9	32	47	20	PHC M28A50...
M28A63	63	20	9	32	47	20	PHC M28A63...
M40A63	63	31	9	35	50	25	PHC M40A63...
M56A63	63	22	11	44	61	30	PHC M56A63...
M56A80	80	30	11	44	61	30	PHC M56A80...
M80A80	80	30	11	48	65	35	PHC M80A80...
M112A80	80	28	14	55	80	40	PHC M112A80...
M112A100	100	40	14	55	80	40	PHC M112A100...
M160A100	100	30	14	62	85	45	PHC M160A100...
M224A125	125	35	18	70	110	55	PHC M224A125...
M224A160	160	60	18	70	110	55	PHC M224A160...
M315A160	160	35	18	80	115	65	PHC M315A160...
M450A200	200	40	18	90	140	75	PHC M450A200...
M650A250	250	50	24	115	190	90	PHC M650A250...
M900A250	250	60	30	140	240	110	PHC M900A250...

To complete designation add attachment spacing and type followed by chain length. For example PHC M20A40-L2A1X10FT (M20A chain with 40 mm pitch with A-1 attachment on every second link, 10 feet chain length).

**Z Series**  
Z - Series

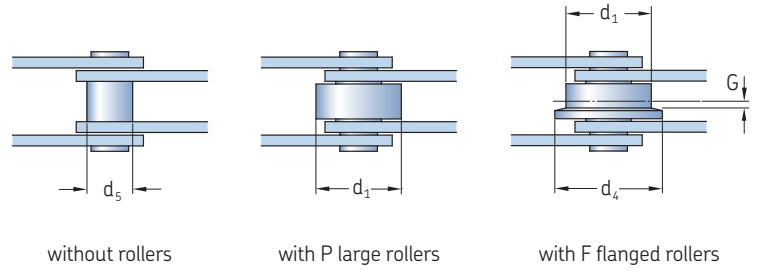
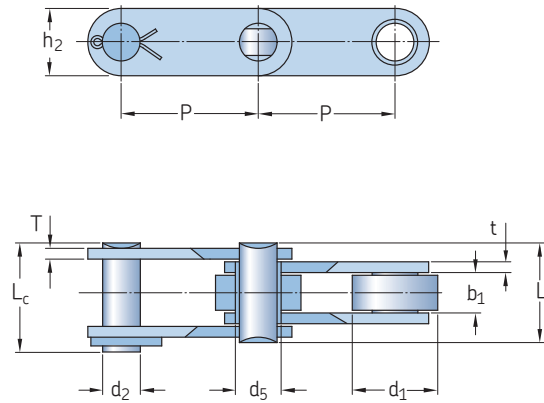

2

Chain number	Pitch sizes available							
	P							
-	mm							
Z13	25,4	38,1	50,8	63,5	76,2	88,9	101,6	
Z33	38,1	50,8	63,5	76,2	88,9	101,6	114,3	
Z 40	50,8	63,5	76,2	88,9	101,6	127,0	152,4	
Z100	76,2	88,9	101,6	127,0	152,4	177,8	203,2	
Z160	101,6	127,0	152,4	177,8	203,2	228,6	254,0	
Z300	152,4	177,8	203,2	254,0	304,8	381,0	457,2	
Z400	152,4	228,6	304,8	381,0	457,2	609,6	-	
Z13XT	25,4	38,1	50,8	63,5	76,2	88,9	101,6	
Z33XT	38,1	50,8	63,5	76,2	88,9	101,6	114,3	
Z40XT	50,8	63,5	is76,2	88,9	101,6	127,0	152,4	
Z100XT	76,2	88,9	101,6	127,0	152,4	177,8	203,2	
Z160XT	101,6	127,0	152,4	177,8	203,2	228,6	254,0	
Z300XT	152,4	177,8	203,2	254,0	304,8	381,0	457,2	
Z400XT	152,4	228,6	304,8	381,0	457,2	609,6	-	

Type	Chain number	Dimensions			Bush diameter d <sub>5</sub> Max.	Width between inner plates b <sub>1</sub> Min.	Pin diameter		Pin length		Plate height h <sub>2</sub> Max.	Plate thickness		Ultimate tensile strength Q Min.	Designation
		d <sub>1</sub> Max.	d <sub>4</sub> Max.	G			d <sub>2</sub> Max.	L Max.	L <sub>c</sub> Max.	t		T Max.			
-	-	mm												kN	-
Z	Z13	25,4	-	-	8,6	11,7	5,7	19,0	21,8	18,0	1,8	1,8	13	PHC Z13...	
	Z33	31,8	-	-	18,0	15,0	14,0	35,0	38,0	25,0	3,8	3,8	33	PHC Z33...	
	Z 40	31,8	40,0	2,5	17,0	15,0	14,0	37,0	40,5	25,0	4,0	4,0	40	PHC Z 40...	
	Z100	47,5	60,0	3,5	23,0	19,0	19,0	45,0	50,5	40,0	5,0	4,0	100	PHC Z100...	
	Z160	66,7	82,0	3,5	33,0	26,0	26,9	58,0	63,5	50,0	7,0	5,0	156	PHC Z160...	
	Z300	88,9	114,0	8,5	38,0	38,0	32,0	84,0	94,0	60,0	10,0	8,0	300	PHC Z300...	
	Z400	88,9	114,0	-	38,0	38,0	29,4	84,0	94,0	63,5	10,0	13,0	400	PHC Z400...	
Z Xtra	Z13XT	25,4	-	-	8,6	11,7	5,7	-	21,8	18,0	1,8	1,8	15	PHC Z13XT...	
	Z33XT	31,8	-	-	18,0	15,0	14,0	-	38,0	25,0	3,8	3,8	34	PHC Z33XT...	
	Z40XT	31,8	40,0	2,5	17,0	15,0	14,0	37,0	40,5	25,0	4,0	4,0	50	PHC Z40XT...	
	Z100XT	47,5	60,0	3,5	23,0	19,0	19,0	45,0	50,5	40,0	5,0	4,0	130	PHC Z100XT...	
	Z160XT	66,7	82,0	3,5	33,0	26,0	26,9	58,0	63,5	50,0	7,0	5,0	200	PHC Z160XT...	
	Z300XT	88,9	114,0	8,5	38,0	38,0	32,0	84,0	94,0	60,0	10,0	8,0	380	PHC Z300XT...	
	Z400XT	88,9	114,0	-	38,0	38,0	29,4	84,0	94,0	63,5	10,0	13,0	400	PHC Z400XT...	

Standard lengths are 10 ft and 5 m. To complete designation add pitch size and chain length. For example, to order Z13 with 25,4 mm pitch without roller in 10 ft length, use designation PHC Z13-25.4X10FT. For ordering a special roller type add letter after pitch size (P for large roller and F for flanged roller). For example, to order Z13 with 25,4 mm pitch with large roller in 10 ft length, use designation PHC Z13-25.4PX10FT.

## Z Series

### ZC - Series hollow pin

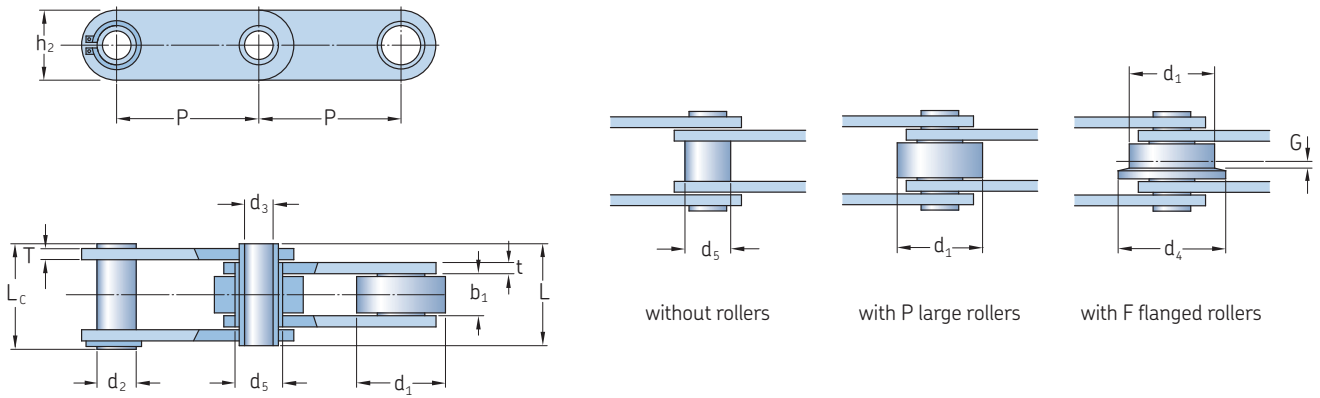

Chain number Pitch sizes available  
P

Chain number	Pitch sizes available P						
-	mm						
ZC21	38,1	50,8	63,5	76,2	88,9	101,6	114,3
ZC40	50,8	63,5	76,2	88,9	101,6	127,0	152,4
ZC60	76,2	88,9	101,6	127,0	152,4	177,8	203,2
ZC150	101,6	127,0	152,4	177,8	203,2	228,6	254,0
ZC300	152,4	177,8	203,2	254,0	304,8	381,0	457,2
ZC40XT	50,8	63,5	76,2	88,9	101,6	127,0	152,4
ZC60XT	76,2	88,9	101,6	127,0	152,4	177,8	203,2
ZC150XT	101,6	127,0	152,4	177,8	203,2	228,6	254,0
ZC300XT	152,4	177,8	203,2	254,0	304,8	381,0	457,2

Type	Chain number	Dimensions			Bush diameter d <sub>5</sub> Max.	Width between inner plates b <sub>1</sub> Min.	Pin diameter		Pin length		Plate height h <sub>2</sub> Max.	Plate thickness		Ultimate tensile strength Q Min.	Designation
		d <sub>1</sub> Max.	d <sub>4</sub> Max.	G			d <sub>2</sub> Max.	d <sub>3</sub> Min.	L Max.	L <sub>2</sub> Max.		t Max.	T Max.		
-	-	mm												kN	-
ZC	ZC21	25,40	-	-	11,0	12,7	9,0	6,5	26,0	27,5	18,0	2,5	2,5	21	PHC ZC21...
	ZC40	31,75	40,0	2,5	17,0	15,0	14,0	10,2	36,4	37,7	25,0	4,0	4,0	40	PHC ZC40...
	ZC60	47,50	60,0	3,5	23,0	19,0	19,0	13,2	45,0	46,0	40,0	5,0	4,0	60	PHC ZC60...
	ZC150	66,70	82,0	3,5	33,0	26,0	26,9	20,2	58,0	60,5	50,0	7,0	5,0	150	PHC ZC150...
	ZC300	88,90	114,0	8,5	38,0	38,0	32,0	22,5	83,0	85,0	60,0	10,0	8,0	300	PHC ZC300...
ZC Xtra	ZC40XT	31,75	40,0	2,5	17,0	15,0	14,0	10,2	36,4	37,7	25,0	4,0	4,0	50	PHC ZC40XT...
	ZC60XT	47,50	60,0	3,5	23,0	19,0	19,0	13,2	45,0	46,0	40,0	5,0	4,0	120	PHC ZC60XT...
	ZC150XT	66,70	82,0	3,5	33,0	26,0	26,9	20,2	58,0	60,5	50,0	7,0	5,0	190	PHC ZC150XT...
	ZC300XT	88,90	114,0	8,5	38,0	38,0	32,0	22,5	83,0	85,0	60,0	10,0	8,0	380	PHC ZC300XT...

Standard lengths are 10 ft and 5 m. To complete designation add pitch size and chain length. For example, to order ZC21 with 38,1 mm pitch without roller in 10 ft length, use designation PHC ZC21-38.1X10FT. For ordering a special roller type add letter after pitch size (P for large roller and F for flanged roller). For example, to order ZC21 with 38,1 mm pitch with large roller in 10 ft length, use designation PHC ZC21-38.1PX10FT.

## Z Series

ZE - Series deep link

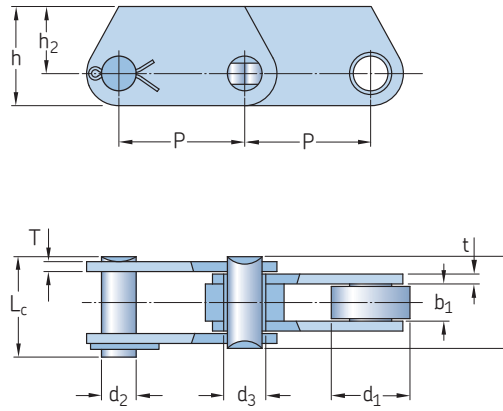

2

Chain number	Pitch sizes available P						
-	mm						
ZE40	50,8	63,5	76,2	88,9	101,6	127,0	152,4
ZE100	76,2	88,9	101,6	127,0	152,4	177,8	203,2
ZE160	101,6	127,0	152,4	177,8	203,2	228,6	254,0
ZE300	152,4	177,8	203,2	254,0	304,8	381,0	457,2
ZE40XT	50,8	63,5	76,2	88,9	101,6	127,0	152,4
ZE100XT	76,2	88,9	101,6	127,0	152,4	177,8	203,2
ZE160XT	101,6	127,0	152,4	177,8	203,2	228,6	254,0
ZE300XT	152,4	177,8	203,2	254,0	304,8	381,0	457,2

Type	Chain number	Dimensions		Width between inner plates $b_1$ Min.	Pin diameter		Pin length		Plate height		Plate thickness		Ultimate tensile strength Q Min.	Designation
		Roller diameter $d_1$ Max.	Bush diameter $d_3$ Max.		$d_2$ Max.	L Max.	$L_c$ Max.	$h_2$ Max.	h Max.	t	T Max.			
-	-	mm											kN	-
ZE	ZE40	31,8	17,0	15,0	14,0	37,0	40,5	40,0	27,0	4,0	4,0	4,0	40	PHC ZE40...
	ZE100	47,5	23,0	19,0	19,0	45,0	50,5	50,0	30,0	5,0	4,0	4,0	100	PHC ZE100...
	ZE160	66,7	33,0	26,0	26,9	58,0	63,5	70,0	45,0	7,0	5,0	5,0	160	PHC ZE160...
	ZE300	88,9	38,0	38,0	32,0	84,0	94,0	90,0	60,0	10,0	8,0	8,0	300	PHC ZE300...
ZE Xtra	ZE40XT	31,8	17,0	15,0	14,0	37,0	40,5	40,0	27,0	4,0	4,0	4,0	60	PHC ZE40XT...
	ZE100XT	47,5	23,0	19,0	19,0	45,0	50,5	50,0	30,0	5,0	4,0	4,0	160	PHC ZE100XT...
	ZE160XT	66,7	33,0	26,0	26,9	58,0	63,5	70,0	45,0	7,0	5,0	5,0	200	PHC ZE160XT...
	ZE300XT	88,9	38,0	38,0	32,0	84,0	94,0	90,0	60,0	10,0	8,0	8,0	380	PHC ZE300XT...

Standard lengths are 10 ft and 5 m. To complete designation add pitch size and chain length. For example, to order Z13 with 25,4 mm pitch without roller in 10 ft length, use designation PHC Z13-25.4X10FT. For ordering a special roller type add letter after pitch size (P for large roller and F for flanged roller). For example, to order Z13 with 25,4 mm pitch with large roller in 10 ft length, use designation PHC Z13-25.4PX10FT.

## Z Series attachments

### K-2, A-2 attachments

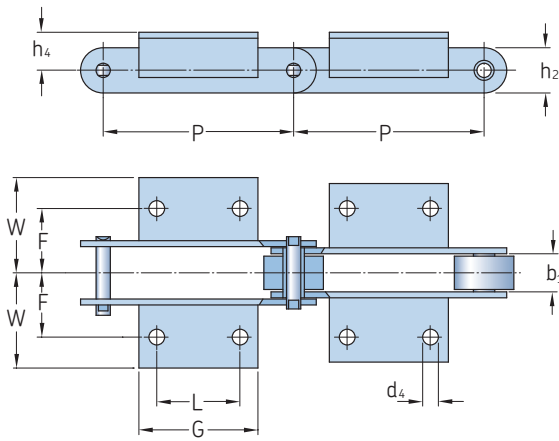

K-2

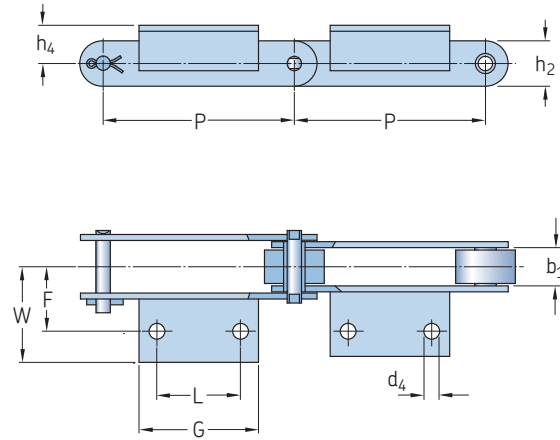

A-2

Chain number	Dimensions							Designation
	Pitch							
	P	L	G	$d_4$	F	W	$h_4$	
–	mm							–
Z40-63.5	63,5	22,2	43,0	9,3	38,1	56,0	19,0	PHC Z40-63.5...
Z40-76.2	76,2	22,2	43,0	9,3	38,1	68,0	19,0	PHC Z40-76.2...
Z100-127.0	127,0	57,2	84,0	10,5	44,5	65,0	32,0	PHC Z100-127.0...
Z100-177.8	177,8	80,0	110,0	10,5	44,5	65,0	32,0	PHC Z100-177.8...
Z100-203.2	203,2	80,0	110,0	10,5	44,5	65,0	32,0	PHC Z100-203.2...
Z160-127.0	127,0	31,7	56,0	12,3	54,0	77,0	38,0	PHC Z160-127.0...
Z160-152.4	152,4	57,2	84,0	12,3	54,0	77,0	38,0	PHC Z160-152.4...
Z160-177.8	177,8	57,2	84,0	12,3	54,0	77,0	38,0	PHC Z160-177.8...
Z160-203.2	203,2	100,0	130,0	12,3	54,0	77,0	38,0	PHC Z160-203.2...
Z160-228.6	228,6	100,0	150,0	12,3	54,0	77,0	38,0	PHC Z160-228.6...
Z160-254.8	254,0	135,0	170,0	12,3	54,0	77,0	38,0	PHC Z160-254.8...
Z300-203.2	203,2	76,2	100,0	14,0	73,0	100,0	51,0	PHC Z300-203.2...
Z300-254.0	254,0	90,0	152,4	14,0	73,0	100,0	51,0	PHC Z300-254.0...
Z300304.8	304,8	190,0	225,0	14,0	73,0	100,0	51,0	PHC Z300304.8...

Footnote: To complete designation add pitch, attachment spacing and type followed by chain length. For example PHC Z40-63.5L2K2X10FT (Z40 chain, 63,5 mm pitch with K-2 attachment on every second link, 10 feet chain length). For ordering a special roller type add letter after pitch size (P for large roller and F for flanged roller), attachment spacing and type followed by chain length. For example, PHC Z40-63.5FL2K2X10FT (Z40 chain, 63,5 mm pitch with flanged roller with K2 attachment on every second link, 10feet chain length).



## Z Series attachments

### K-1, A-1 attachments

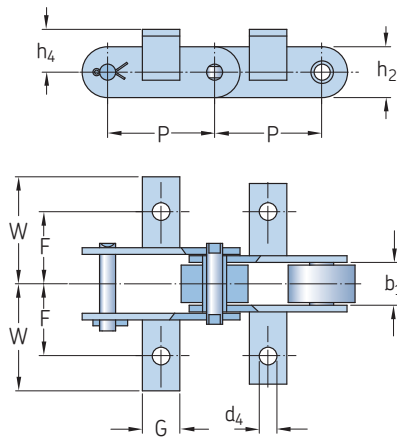

K-1

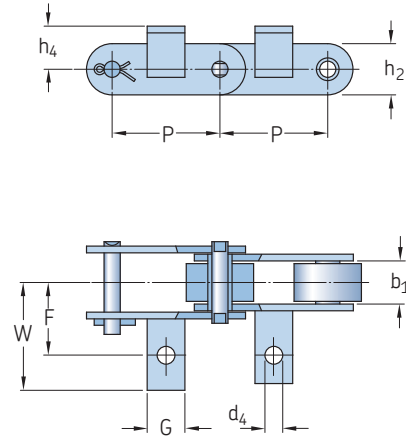

A-1

Chain number	Dimensions						Designation
	Pitch						
	P	G	d <sub>4</sub>	F	W	h <sub>4</sub>	
	mm						
Z40-50.8	50,8	45,0	9,3	38,1	64,5	19,0	PHC Z40-50.8...
Z40-63.5	63,5	43,0	9,3	38,1	56,0	19,0	PHC Z40-63.5...
Z40-76.2	76,2	43,0	9,3	38,1	68,0	19,0	PHC Z40-76.2...
Z100-76.2	76,2	30,0	10,5	44,5	65,0	32,0	PHC Z100-76.2...
Z100-88.9	88,9	30,0	10,5	44,5	65,0	32,0	PHC Z100-88.9...
Z100-127.0	127,0	84,0	10,5	44,5	65,0	32,0	PHC Z100-127.0...
Z100-177.8	177,8	110,0	10,5	44,5	65,0	32,0	PHC Z100-177.8...
Z100-203.2	203,2	110,0	10,5	44,5	65,0	32,0	PHC Z100-203.2...
Z160-101.6	101,6	35,0	12,3	54,0	77,0	38,0	PHC Z160-101.6...
Z160-127.0	127,0	56,0	12,3	54,0	77,0	38,0	PHC Z160-127.0...
Z160-152.4	152,4	84,0	12,3	54,0	77,0	38,0	PHC Z160-152.4...
Z160-177.8	177,8	84,0	12,3	54,0	77,0	38,0	PHC Z160-177.8...
Z160-203.2	203,2	130,0	12,3	54,0	77,0	38,0	PHC Z160-203.2...
Z160-228.6	228,6	150,0	12,3	54,0	77,0	38,0	PHC Z160-228.6...
Z160-254.0	254,0	170,0	12,3	54,0	77,0	38,0	PHC Z160-254.0...
Z300-152.4	152,4	70,0	14,0	73,0	100,0	51,0	PHC Z300-152.4...
Z300-177.8	177,8	70,0	14,0	73,0	100,0	51,0	PHC Z300-177.8...
Z300-203.5	203,2	100,0	14,0	73,0	100,0	51,0	PHC Z300-203.5...
Z300-254.0	254,0	152,4	14,0	73,0	100,0	51,0	PHC Z300-254.0...
Z300-304.8	304,8	225,0	14,0	73,0	100,0	51,0	PHC Z300-304.8...

Footnote: To complete designation add pitch, attachment spacing and type followed by chain length. For example PHC Z4050.8-L2A1X10FT (Z40 chain, 50,8 mm pitch with A-1 attachment on every second link, 10 feet chain length). For ordering a special roller type add letter after pitch size (P for large roller and F for flanged roller), attachment spacing and type followed by chain length. For example, PHC Z40-50.8FL2K1X10FT (Z40 chain, 63,5 mm pitch with flanged roller with K1 attachment on every second link, 10feet chain length).

**FV Series**  
FV Series

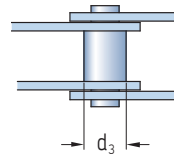
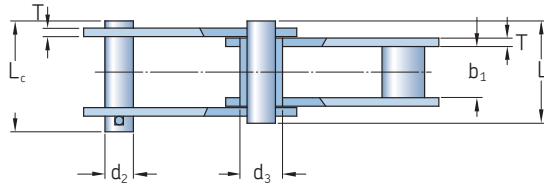
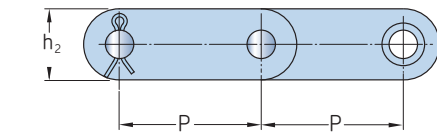

without rollers

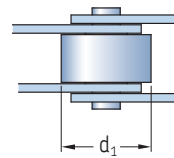

with P large rollers

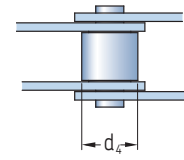

with S small rollers

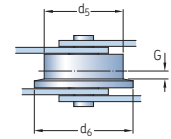

with F flanged rollers

Chain number	Pitch sizes available										
	P		mm								
–	–		–					–		–	
FV40	50	63	80	100	125	–	–	–	–	–	
FV63	63	80	100	125	160	–	–	–	–	–	
FV90	63	80	100	125	160	200	250	–	–	–	
FV112	100	125	160	200	250	–	–	–	–	–	
FV140	100	125	160	200	250	–	–	–	–	–	
FV180	125	160	200	250	315	–	–	–	–	–	
FV250	160	200	250	315	400	–	–	–	–	–	
FV315	160	200	250	315	400	–	–	–	–	–	
FV400	160	200	250	315	400	500	1 000	–	–	–	
FV500	160	200	250	315	400	500	1 000	–	–	–	
FV630	200	250	315	400	500	1000	–	–	–	–	
FV40XT	50	63	80	100	125	–	–	–	–	–	
FV63XT	63	80	100	125	160	–	–	–	–	–	
FV90XT	63	80	100	125	160	200	250	–	–	–	
FV112XT	100	125	160	200	250	–	–	–	–	–	
FV140XT	100	125	160	200	250	–	–	–	–	–	
FV180XT	125	160	200	250	315	–	–	–	–	–	
FV250XT	160	200	250	315	400	–	–	–	–	–	
FV315XT	160	200	250	315	400	–	–	–	–	–	
FV400XT	160	200	250	315	400	500	1 000	–	–	–	
FV500XT	160	200	250	315	400	500	1 000	–	–	–	
FV630XT	200	250	315	400	500	1 000	–	–	–	–	

Type	Chain number	Dimensions					Bush diameter d <sub>3</sub> Max.	Width between inner plates b <sub>1</sub> Min.	Pin diameter d <sub>2</sub> Max.	Pin length		Plate height h <sub>2</sub> Max.	Plate thickness T Max.	Ultimate tensile strength Q Min.	Designation
		d <sub>1</sub> Max.	d <sub>4</sub> Max.	d <sub>5</sub> Max.	d <sub>6</sub> Max.	G				L Max.	L <sub>c</sub> Max.				
–	–	mm					–	–	–	–	–	–	–	kN	–
FV	FV40	32	20	40	50	4,0	15	18	10	36	39,0	25	3	40	PHC FV40...
	FV63	40	26	50	63	5,0	18	22	12	45	48,5	30	4	63	PHC FV63...
	FV90	48	30	63	78	6,5	20	25	14	53	56,5	35	5	90	PHC FV90...
	FV112	55	32	72	90	7,5	22	30	16	62	66,0	40	6	112	PHC FV112...
	FV140	60	36	80	100	9,0	26	35	18	67	71,5	45	6	140	PHC FV140...
	FV180	70	42	100	125	13,0	30	45	20	86	92,0	50	8	180	PHC FV180...
	FV250	80	50	125	155	15,0	36	55	26	97	103,5	60	8	250	PHC FV250...
	FV315	90	60	140	175	18,0	42	65	30	113	126,5	70	10	315	PHC FV315...
	FV400	100	60	150	185	–	44	70	32	130	*	70	12	400	PHC FV400...
	FV500	110	70	160	195	–	50	80	36	140	*	80	12	500	PHC FV500...
FV630	120	80	170	210	–	56	90	42	152	*	100	12	630	PHC FV630...	
FV Xtra	FV40XT	32	20	40	50	4,0	15	18	10	36	39,0	25	3	47	PHC FV40XT...
	FV63XT	40	26	50	63	5,0	18	22	12	45	48,5	30	4	75	PHC FV63XT...
	FV90XT	48	30	63	78	6,5	20	25	14	53	56,5	35	5	115	PHC FV90XT...
	FV112XT	55	32	72	90	7,5	22	30	16	62	66,0	40	6	170	PHC FV112XT...
	FV140XT	60	36	80	100	9,0	26	35	18	67	71,5	45	6	180	PHC FV140XT...
	FV180XT	70	42	100	125	13,0	30	45	20	86	92,0	50	8	250	PHC FV180XT...
	FV250XT	80	50	125	155	15,0	36	55	26	97	103,5	60	8	300	PHC FV250XT...
	FV315XT	90	60	140	175	18,0	42	65	30	113	126,5	70	10	480	PHC FV315XT...
	FV400XT	100	60	150	185	*	44	70	32	130	*	70	12	400	PHC FV400XT...
	FV500XT	110	70	160	195	*	50	80	36	140	*	80	12	500	PHC FV500XT...
FV630XT	120	80	170	210	*	56	90	42	152	*	100	12	630	PHC FV630XT...	

Standard lengths are 10 ft and 5 m. To complete designation add pitch size and chain length. For example, to order FV40 with 50 mm pitch without roller in 10 ft length, use designation PHC FV40-50X10FT. For ordering a special roller type add letter after pitch size (S for small roller, P for large roller and F for flanged roller). For example, to order FV40 with 50 mm pitch with large roller in 10 ft length, use designation PHC FV40-50PX10FT.

## FV Series

### FVC Series

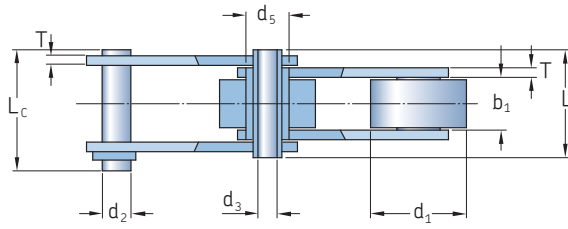
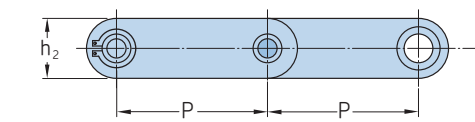

FVC Series

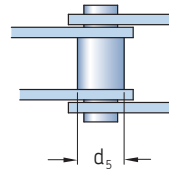

without rollers

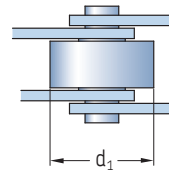

with P large rollers

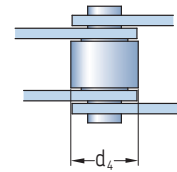

with S small rollers

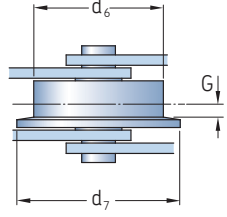

with F flanged rollers

Chain number	Pitch sizes available							
	P							
–	mm							
FVC63	63	80	100	125	160	–	–	–
FVC90	63	80	100	125	160	200	250	–
FVC112	100	125	160	200	250	–	–	–
FVC140	100	125	160	200	250	–	–	–
FVC180	125	160	200	250	315	–	–	–
FVC250	160	200	250	315	400	–	–	–
FVC315	160	200	250	315	400	–	–	–

Chain number	Dimensions					Width between inner plates b1 Min.	Pin diameter		Bush diameter d5 Max.	Pin length L Max.	Lc Max.	Plate thickness T Max.	Plate height h2 Max.	Ultimate tensile strength σ Min.	Designation
	d1 Max.	d4 Max.	d6 Max.	d7 Max.	G		d2 Max.	d3 Min.							
–	mm											kN	–		
FVC63	40	26	50	63	5,0	22	12	8	18	45	51	4	30	46	PHC FVC63...
FVC90	48	30	63	78	6,5	25	14	10	20	53	57	5	35	73	PHC FVC90...
FVC112	55	32	72	90	7,5	30	16	11	22	62	63	6	40	90	PHC FVC112...
FVC140	60	36	80	100	9,0	35	18	12	26	67	69	6	45	110	PHC FVC140...
FVC180	70	42	100	125	13,0	45	20	14	30	86	88	8	50	145	PHC FVC180...
FVC250	80	50	125	155	15,0	55	26	18	36	97	104	8	60	215	PHC FVC250...
FVC315	90	60	140	175	18,0	65	30	20	42	113	122	10	70	295	PHC FVC315...

Standard lengths are 10 ft and 5 m. To complete designation add pitch size and chain length. For example, to order FVC63 with 63 mm pitch without roller in 10 ft length, use designation PHC FVC63-63X10FT. For ordering a special roller type add letter after pitch size (S for small roller, P for large roller and F for flanged roller). For example, to order FVC63 with 63 mm pitch with large roller in 10 ft length, use designation PHC FVC63-63PX10FT.

**FV Series**  
FVT Series

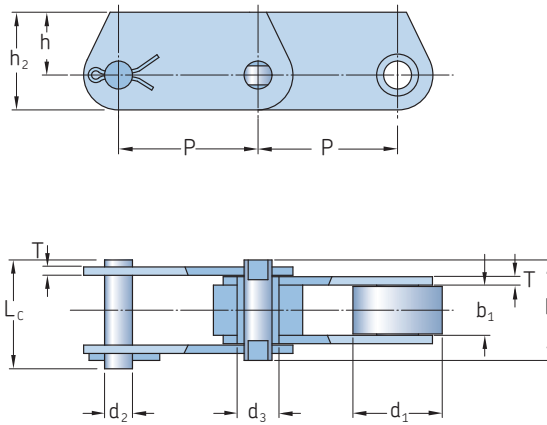

Chain number	Pitch sizes available P							
-	mm							
FVT40	50	63	80	100	125	-	-	
FVT63	63	80	100	125	160	-	-	
FVT90	63	80	100	125	160	200	250	
FVT112	100	125	160	200	250	-	-	
FVT140	100	125	160	200	250	-	-	
FVT180	125	160	200	250	315	-	-	
FVT250	160	200	250	315	-	-	-	
FVT315	160	200	250	315	400	-	-	
FVT40XT	50	63	80	100	125	-	-	
FVT63XT	63	80	100	125	160	-	-	
FVT90XT	63	80	100	125	160	200	250	
FVT112XT	100	125	160	200	250	-	-	
FVT140XT	100	125	160	200	250	-	-	
FVT180XT	125	160	200	250	315	-	-	
FVT250XT	160	200	250	315	-	-	-	
FVT315XT	160	200	250	315	400	-	-	

Type	Chain number	Dimensions		Width between inner plates b <sub>1</sub> Min.	Pin diameter d <sub>2</sub> Max.	Pin length		Plate height		Plate thickness T Max.	Ultimate tensile strength Q Min.	Designation
		Roller diameter d <sub>1</sub> Max.	Bush diameter d <sub>3</sub> Max.			L	L <sub>c</sub> Max.	h <sub>2</sub> Max.	h Max.			
-	-	mm									kN	-
FVT	FVT40	32	15	18	10	36	39,0	35	22,5	3	40	PHC FVT40...
	FVT63	40	18	22	12	45	48,5	40	25,0	4	63	PHC FVT63...
	FVT90	48	20	25	14	53	56,5	45	27,5	5	90	PHC FVT90...
	FVT112	55	22	30	16	62	66,0	50	30,0	6	112	PHC FVT112...
	FVT140	60	25	35	18	67	71,5	60	37,5	6	140	PHC FVT140...
	FVT180	70	30	45	20	86	92,0	70	45,0	8	180	PHC FVT180...
	FVT250	80	36	55	26	97	103,5	80	50,0	8	250	PHC FVT250...
FVT315	90	42	65	30	113	126,5	90	55,0	10	315	PHC FVT315...	
Xtra	FVT40XT	32	15	18	10	36	39,0	35	22,5	3	47	PHC FVT40XT...
	FVT63XT	40	18	22	12	45	48,5	40	25,0	4	75	PHC FVT63XT...
	FVT90XT	48	20	25	14	53	56,5	45	27,5	5	115	PHC FVT90XT...
	FVT112XT	55	22	30	16	62	66,0	50	30,0	6	170	PHC FVT112XT...
	FVT140XT	60	25	35	18	67	71,5	60	37,5	6	180	PHC FVT140XT...
	FVT180XT	70	30	45	20	86	92,0	70	45,0	8	250	PHC FVT180XT...
	FVT250XT	80	36	55	26	97	103,5	80	50,0	8	300	PHC FVT250XT...
FVT315XT	90	42	65	30	113	126,5	90	55,0	10	480	PHC FVT315XT...	

Standard lengths are 10 ft and 5 m. To complete designation add pitch size and chain length. For example, to order FVT40 with 50 mm pitch without roller in 10 ft length, use designation PHC FVT40-50X10FT. For ordering a special roller type add letter after pitch size (S for small roller, P for large roller and F for flanged roller). For example, to order FVT40 with 50 mm pitch with large roller in 10 ft length, use designation PHC FVT40-50PX10FT.

## FV Series attachments

### K-2, A-2 attachments

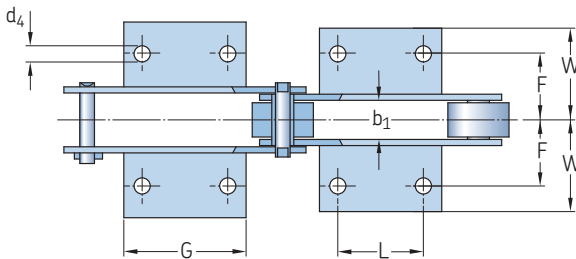
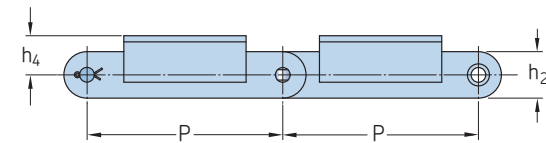

K-2

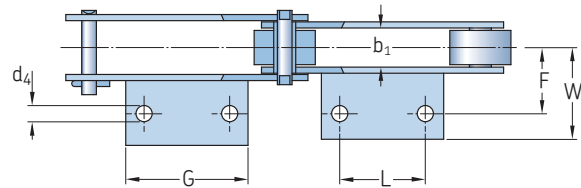
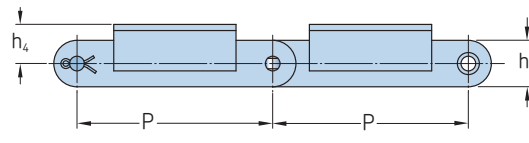

A-2

Chain number	Dimensions								Designation
	Pitch								
	P	L	G	d <sub>4</sub>	F	W	h <sub>4</sub>		
-	mm								-
FV40	80	25	45	6,6	25	40,5	20	PHC FV40...	
FV40	100	30	50	6,6	25	40,5	20	PHC FV40...	
FV40	125	30	60	6,6	25	40,5	20	PHC FV40...	
FV63	80	25	45	8,4	34	50,0	30	PHC FV63...	
FV63	100	30	50	8,4	34	50,0	30	PHC FV63...	
FV63	125	40	60	8,4	34	50,0	30	PHC FV63...	
FV63	160	50	70	8,4	34	50,0	30	PHC FV63...	
FV90	80	25	45	8,4	40	64,0	35	PHC FV90...	
FV90	100	30	50	8,4	40	64,0	35	PHC FV90...	
FV90	125	40	60	8,4	40	64,0	35	PHC FV90...	
FV90	160	50	70	8,4	40	64,0	35	PHC FV90...	
FV90	200	60	80	8,4	40	64,0	35	PHC FV90...	
FV90	250	65	85	8,4	40	64,0	35	PHC FV90...	
FV112	100	30	50	11,0	50	70,0	40	PHC FV112...	
FV112	125	40	65	11,0	50	70,0	40	PHC FV112...	
FV112	160	50	75	11,0	50	70,0	40	PHC FV112...	
FV112	200	65	90	11,0	50	70,0	40	PHC FV112...	
FV112	250	80	105	11,0	50	70,0	40	PHC FV112...	
FV140	100	30	55	11,0	50	81,0	45	PHC FV140...	
FV140	125	40	65	11,0	50	81,0	45	PHC FV140...	
FV140	160	50	75	11,0	50	81,0	45	PHC FV140...	
FV140	200	65	90	11,0	50	81,0	45	PHC FV140...	
FV140	250	80	105	11,0	50	81,0	45	PHC FV140...	
FV180	125	35	63	13,0	64	91,0	45	PHC FV180...	
FV180	160	50	80	13,0	64	91,0	45	PHC FV180...	
FV180	200	65	95	13,0	64	91,0	45	PHC FV180...	
FV180	250	80	110	13,0	64	91,0	45	PHC FV180...	
FV180	315	100	130	13,0	64	91,0	45	PHC FV180...	
FV250	160	50	80	14,0	69	106,0	55	PHC FV250...	
FV250	200	65	95	14,0	69	106,0	55	PHC FV250...	
FV250	250	80	110	14,0	69	106,0	55	PHC FV250...	
FV250	315	100	130	14,0	69	106,0	55	PHC FV250...	
FV250	400	100	130	14,0	69	106,0	55	PHC FV250...	
FV315	200	65	95	14,0	85	130,0	60	PHC FV315...	
FV315	250	80	110	14,0	85	130,0	60	PHC FV315...	
FV315	315	100	130	14,0	85	130,0	60	PHC FV315...	
FV315	400	100	130	14,0	85	130,0	60	PHC FV315...	
FV400	200	60	100	18,0	95	145,0	65	PHC FV400...	
FV400	250	80	120	18,0	95	145,0	65	PHC FV400...	
FV400	315	100	140	18,0	95	145,0	65	PHC FV400...	
FV400	400	100	140	18,0	95	145,0	65	PHC FV400...	
FV400	500	100	140	18,0	95	145,0	65	PHC FV400...	
FV400	1000	125	200	18,0	95	145,0	65	PHC FV400...	
FV500	200	50	90	18,0	100	150,0	70	PHC FV500...	
FV500	250	80	120	18,0	100	150,0	70	PHC FV500...	
FV500	315	100	140	18,0	100	150,0	70	PHC FV500...	
FV500	400	100	140	18,0	100	150,0	70	PHC FV500...	
FV500	500	100	140	18,0	100	150,0	70	PHC FV500...	
FV500	1000	125	200	18,0	100	150,0	70	PHC FV500...	
FV630	250	70	110	18,0	115	175,0	80	PHC FV630...	
FV630	315	100	140	18,0	115	175,0	80	PHC FV630...	
FV630	400	100	140	18,0	115	175,0	80	PHC FV630...	
FV630	500	100	140	18,0	115	175,0	80	PHC FV630...	
FV630	1000	125	200	18,0	115	175,0	80	PHC FV630...	

To complete designation add pitch, attachment spacing and type followed by chain length. For example PHC FV4080-L2K2X10FT (FV40 chain, 80 mm pitch with K-2 attachment on every second link, 10 feet chain length).

## FV Series attachments

### K-1, A-1 attachments

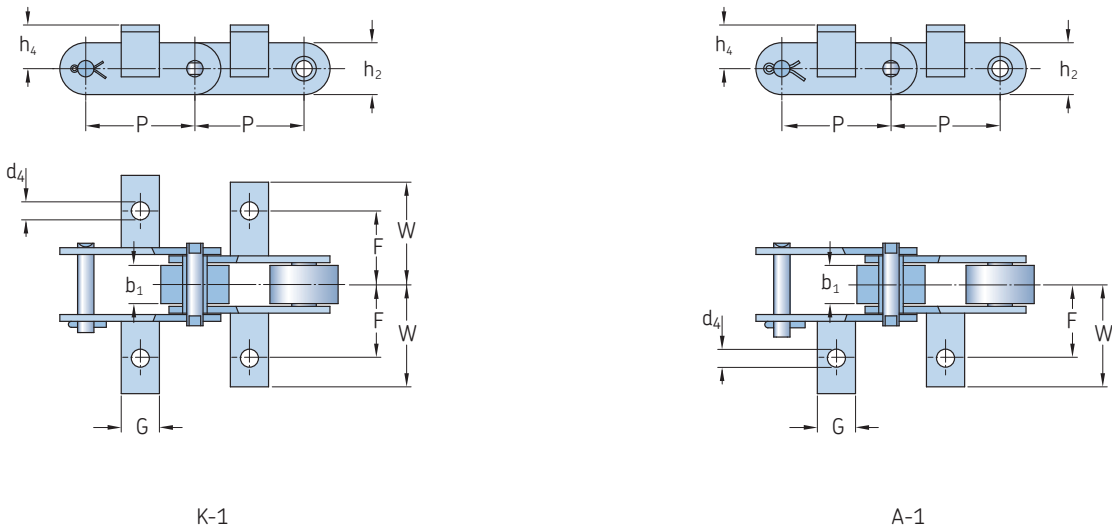

Chain number	Dimensions						Designation
	Pitch						
	P	G	d <sub>4</sub>	F	W	h <sub>4</sub>	
–	mm						–
FV40	50	45	6,6	25	40,5	20	PHC FV40...
FV40	63	31	6,6	25	40,5	20	PHC FV40...
FV63	63	40	8,4	34	50,0	30	PHC FV63...
FV90	63	30	8,4	40	64,0	35	PHC FV90...
FV315	160	50	14,0	85	130,0	60	PHC FV315...
FV400	160	50	18,0	95	145,0	65	PHC FV400...
FV500	160	50	18,0	100	150,0	70	PHC FV500...
FV630	200	50	18,0	115	175,0	80	PHC FV630...

To complete designation add pitch, attachment spacing and type followed by chain length. For example PHC FV4050-L2K1X10FT (FV40 chain, 50 mm pitch with K-1 attachment on every second link, 10 feet chain length).

# W Series (Welded steel mill and drag chains)

W, WH | WD

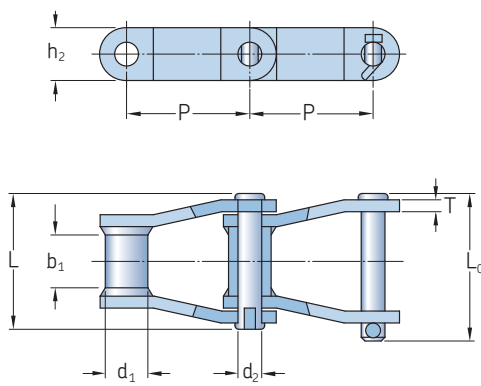

W and WH (mill series)

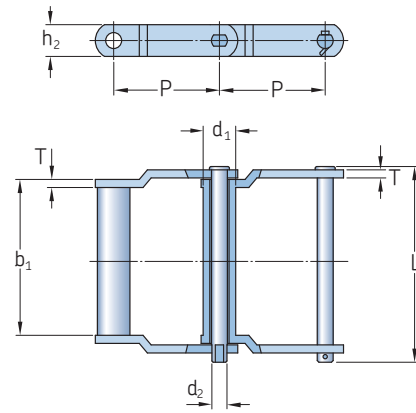

WD (drag)

Type	Chain number	Dimensions Pitch P	Bush diameter d <sub>1</sub> Max.	Width between Pin diameter inner plates		Pin length		Plate height h <sub>2</sub> Max.	Plate thickness T	Ultimate tensile strength Q Min.	Average tensile strength Q <sub>0</sub>	Mass per meter q	Designation		
				b <sub>1</sub> Min.	d <sub>2</sub> Max.	L Max.	L <sub>c</sub> Max.								
mm													kN	Kg/m	-
W	W78	66,27	22,90	28,40	12,78	73,00	79,30	28,40	6,40	93,40	102,70	6,20	PHC W78...		
	W82	78,10	31,50	31,80	14,35	80,00	86,00	31,80	6,40	100,10	110,10	7,98	PHC W82...		
	W106	152,40	37,10	41,20	19,13	103,00	111,00	38,10	9,70	169,00	185,90	10,56	PHC W106...		
	W110	152,40	32,00	46,70	19,13	107,70	115,50	38,10	9,70	169,00	185,90	10,40	PHC W110...		
	W111	120,90	37,10	57,20	19,13	116,80	124,50	38,10	9,70	169,00	185,90	12,72	PHC W111...		
	W124	101,60	37,10	41,20	19,13	103,00	110,00	38,10	9,70	169,00	185,90	12,38	PHC W124...		
	W124H	103,20	41,70	41,20	22,30	131,60	133,00	50,80	12,70	275,80	303,30	19,68	PHC W124H...		
	W132	153,67	44,70	76,20	25,48	151,00	162,20	50,80	12,70	275,80	303,30	20,00	PHC W132...		
	W134	103,20	41,27	76,20	25,40	113,49	125,42	63,50	12,70	380,00	458,20	24,86	PHC W134...		
	W150	153,67	44,45	73,00	25,40	151,00	162,20	63,50	12,70	620,00	682,00	7,74	PHC W150...		
	W155	153,67	44,45	73,00	28,57	164,00	176,00	63,50	12,70	820,00	902,00	9,00	PHC W155...		
	W157	153,67	44,45	76,20	28,57	164,00	176,00	63,50	15,90	820,00	902,00	9,10	PHC W157...		
	W182	78,11	34,93	57,15	19,05	84,93	100,81	38,10	9,53	170,50	204,63	12,35	PHC W182...		
	W784	101,60	22,23	50,80	12,70	72,23	80,16	28,58	6,35	90,00	106,76	4,91	PHC W784...		
	WH	WH78	66,27	22,90	28,40	12,78	73,00	79,30	28,40	6,40	106,80	117,50	6,20	PHC WH78...	
WH82		78,10	31,50	31,80	14,35	80,00	86,00	31,80	6,40	131,20	144,30	7,98	PHC WH82...		
WH106		152,40	37,10	41,20	19,13	103,00	111,00	38,10	9,70	224,60	247,00	10,56	PHC WH106...		
WH110		152,40	32,00	46,70	19,13	107,70	115,50	38,10	9,70	224,60	247,00	10,40	PHC WH110...		
WH111		120,90	37,10	57,20	19,13	116,80	124,50	38,10	9,70	224,60	247,00	12,72	PHC WH111...		
WH124		101,60	37,10	41,20	19,13	103,00	110,00	38,10	9,70	224,60	247,00	12,38	PHC WH124...		
WH124H		103,20	41,70	41,20	22,30	131,60	133,00	50,80	12,70	355,90	391,40	19,68	PHC WH124H...		
WH132		153,67	44,70	76,20	25,48	151,00	162,20	50,80	12,70	378,10	415,90	20,00	PHC WH132...		
WH134		103,20	41,27	76,20	25,40	113,49	125,42	63,50	12,70	415,00	498,22	24,86	PHC WH134...		
WH150		153,67	44,45	73,00	25,40	151,00	162,20	63,50	12,70	620,00	682,00	7,74	PHC WH150...		
WH155		153,67	44,45	73,00	28,57	164,00	176,00	63,50	12,70	820,00	902,00	9,00	PHC WH155...		
WH157		153,67	44,45	76,20	28,57	164,00	176,00	63,50	15,90	820,00	902,00	9,10	PHC WH157...		
WH784		101,60	22,23	50,80	12,70	72,23	80,16	28,58	6,35	111,20	133,45	4,91	PHC WH784...		
WD		WD102	127,00	-	197,10	19,13	245,40	-	38,12	9,70	245,00	-	-	PHC WD102...	
		WD104	152,40	-	136,90	19,13	181,40	-	38,12	9,70	245,00	-	-	PHC WD104...	
	WD110	152,40	-	263,90	19,13	308,60	-	38,12	9,70	245,00	-	-	PHC WD110...		
	WD112	203,20	-	263,90	19,13	308,60	-	38,12	9,70	245,00	-	-	PHC WD112...		
	WD113	152,40	-	270,30	22,30	322,30	-	38,12	12,70	253,00	-	-	PHC WD113...		
	WD116	203,20	-	359,20	19,13	405,90	-	45,21	9,70	262,00	-	-	PHC WD116...		
	WD118	203,20	-	378,20	22,30	431,10	-	51,80	12,70	351,00	-	-	PHC WD118...		
	WD120	152,40	-	260,35	22,30	307,24	-	50,80	12,70	311,00	-	-	PHC WD120...		
	WD122	203,20	-	260,60	22,30	314,50	-	51,80	12,70	351,00	-	-	PHC WD122...		
	WD480	203,20	-	324,10	22,30	378,00	-	51,80	12,70	351,00	-	-	PHC WD480...		

Standard lengths are 10 ft and 5 m. To complete designation add chain length. For example, to order W78 in 10 ft length, use designation PHC W78X10FT.

## W Series attachments

K-1, A-1 attachments | K-2, A-2 attachments

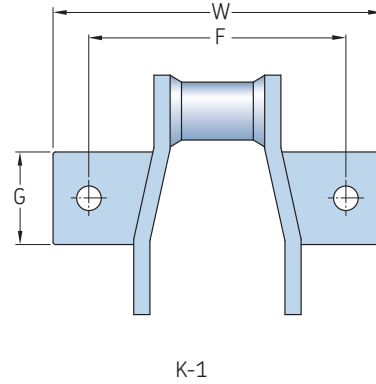
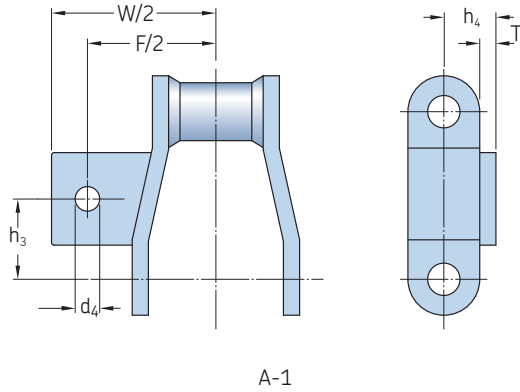

Chain number	Dimensions								Designation
	$h_3$	G	F	W	$h_4$	$d_4$	T		
-	mm								-
W78	31,8	36,6	101,6	130,0	22,4	9,7	6,4	PHC W78...	
WH78	31,8	36,6	101,6	130,0	22,4	9,7	6,4	PHC WH78...	
W82	38,1	46,0	106,7	142,7	23,9	9,7	6,4	PHC W82...	
WH82	38,1	46,0	106,7	142,7	23,9	9,7	6,4	PHC WH82...	

To complete designation add attachment spacing and type followed by chain length. For example PHC W78-L2K1X10FT (W78 chain with K-1 attachment on every second link, 10 feet chain length).

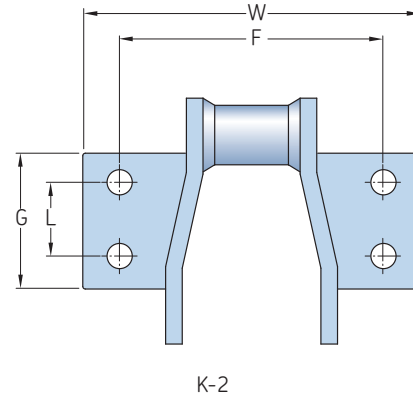
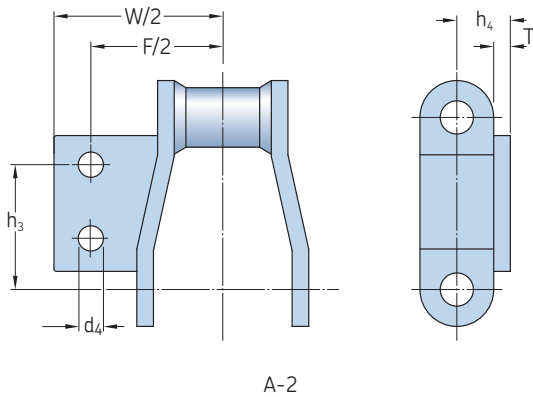

Chain number	Dimensions									Designation
	L	G	$h_3$	F	W	$h_4$	$d_4$	T		
-	mm									-
W78	28,4	52,3	38,9	101,6	130,0	22,4	9,7	6,4	PHC W78...	
WH78	28,4	52,3	38,9	101,6	130,0	22,4	9,7	6,4	PHC WH78...	
W82	33,3	62,0	52,3	108,2	142,7	23,9	9,7	6,4	PHC W82...	
WH82	33,3	62,0	52,3	108,2	142,7	23,9	9,7	6,4	PHC WH82...	
W110	44,4	84,1	98,6	135,1	168,1	30,0	9,7	9,7	PHC W110...	
WH110	44,4	84,1	98,6	135,1	168,1	30,0	9,7	9,7	PHC WH110...	
W111	58,7	90,4	89,9	159,0	193,5	30,0	12,7	9,7	PHC W111...	
WH111	58,7	90,4	89,9	159,0	193,5	30,0	12,7	9,7	PHC WH111...	
W124	49,3	77,7	71,4	133,6	180,8	30,0	9,7	9,7	PHC W124...	
WH124	49,3	77,7	71,4	133,6	180,8	30,0	9,7	9,7	PHC WH124...	
W124H	49,3	80,8	73,2	133,6	165,6	39,6	12,7	12,7	PHC W124H...	
WH124H	49,3	80,8	73,2	133,6	165,6	39,6	12,7	12,7	PHC WH124H...	
W132	69,8	80,8	106,2	190,5	234,7	39,6	12,7	12,7	PHC W132...	
WH132	69,8	80,8	106,2	190,5	234,7	39,6	12,7	12,7	PHC WH132...	

To complete designation add attachment spacing and type followed by chain length. For example PHC W78-L2K2X10FT (W78 chain with K-2 attachment on every second link, 10 feet chain length).



## W Series attachments

A-22 attachments | H-1 attachments

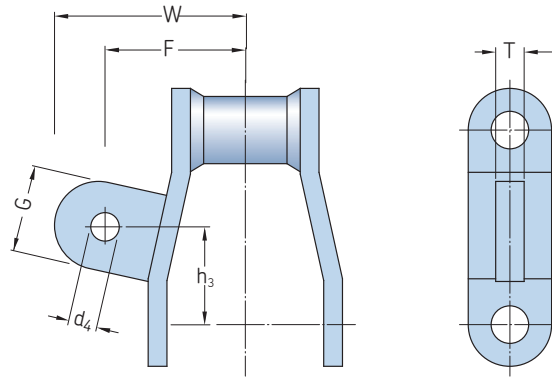

A-22

Chain number	Dimensions						Designation
	$h_3$	G	F	W	$d_4$	T	
-	mm						-
W78	33,3	30	47,8	65	9,7	9,7	PHC W78...
WH78	33,3	30	47,8	65	9,7	9,7	PHC WH78...

To complete designation add attachment spacing and type followed by chain length. For example PHCW78-L2A22X10FT (W78 chain with A-22 attachment on every second link, 10 feet chain length).

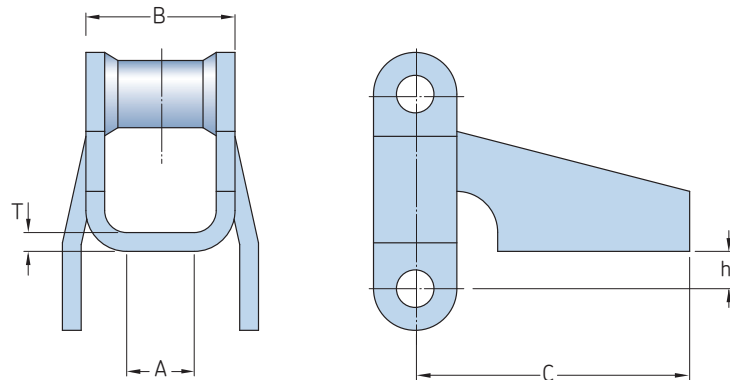

H-1

Chain number	Dimensions					Designation
	$h_3$	A*	B	C	T	
-	mm					-
W78	12,7	22,4	50,8	93,5	6,4	PHC W78...
WH78	12,7	22,4	50,8	93,5	6,4	PHC WH78...
W82	15,7	28,4	57,2	93,5	6,4	PHC W82...
WH82	15,7	28,4	57,2	93,5	6,4	PHC WH82

\* A indicates flat surface width of attachment.

To complete designation add attachment spacing and type followed by chain length. For example PHCW78-L2H1X10FT (W78 chain with H-1 attachment on every second link, 10 feet chain length).

## W Series attachments

H-2 attachments | F-2 attachments

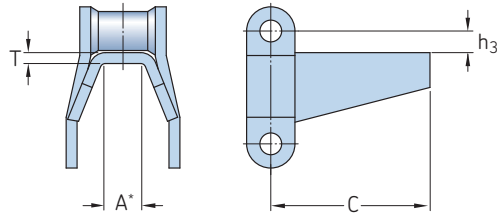

H-2

Chain number	Dimensions				Designation
	$h_3$	A	C	T	
–	mm				–
W78	7,9	20,8	93,5	6,4	PHC W78...
WH78	7,9	20,8	93,5	6,4	PHC WH78...
W82	7,9	26,4	96,8	6,4	PHC W82...
WH82	7,9	26,4	96,8	6,4	PHC WH82...

\* A indicates flat surface width of attachment.

To complete designation add attachment spacing and type followed by chain length. For example PHC W78-L2H2X10FT (W78 chain with H-2 attachment on every second link, 10 feet chain length).

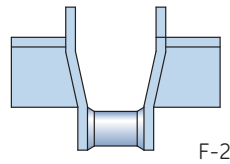
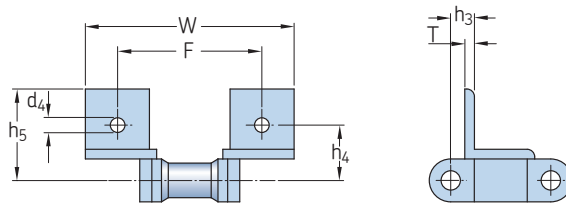

F-2

Chain number	Dimensions							Designation
	$h_3$	$h_4$	$h_5$	F	W	$d_4$	T	
–	mm							–
W78	15,7	36,6	60,5	95,5	138,2	9,7	6,4	PHC W78...
WH78	15,7	36,6	60,5	95,5	138,2	9,7	6,4	PHC WH78...

To complete designation add attachment spacing and type followed by chain length. For example PHC W78-L2F2X10FT (W78 chain with F-2 attachment on every second link, 10 feet chain length).

## W Series attachments

F-4 attachments | R-1, RR-1 attachments

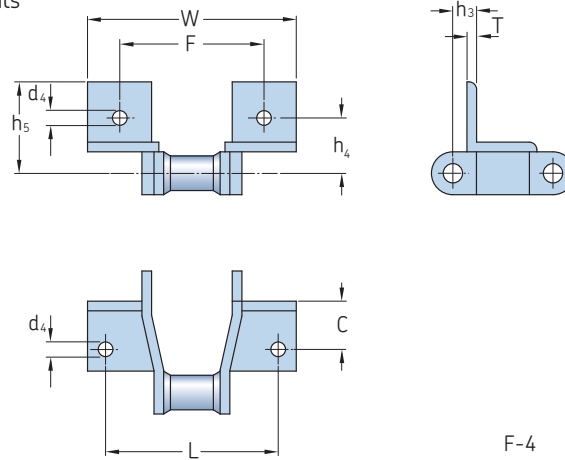

Chain number	Dimensions									Designation
	$h_3$	$h_4$	$h_5$	L	C	F	W	$d_4$	T	
-	mm									-
W78	17,3	44,4	60,5	114,3	31,8	95,2	141,2	9,7	6,4	PHC W78...
WH78	17,3	44,4	60,5	114,3	31,8	95,2	141,2	9,7	6,4	PHC WH78...
W82	20,6	46,2	62,0	127,0	28,4	104,6	150,9	9,7	6,4	PHC W82...
WH82	20,6	46,2	62,0	127,0	28,4	104,6	150,9	9,7	6,4	PHC WH82...
W124	22,4	52,3	73,2	133,6	36,6	111,3	157,0	9,7	9,7	PHC W124...
WH124	22,4	52,3	73,2	133,6	36,6	111,3	157,0	9,7	9,7	PHC WH124...

To complete designation add attachment spacing and type followed by chain length. For example PHCW78-L2F4X10FT (W78 chain with F-4 attachment on every second link, 10 feet chain length).



Chain number	Dimensions			Designation
	$h_3$	C	T	
-	mm			-
W78	17,3	41,1	6,4	PHC W78...
WH78	17,3	41,1	6,4	PHC WH78...
W82	22,4	49,3	6,4	PHC W82...
WH82	22,4	49,3	6,4	PHC WH82...
W124	31,8	49,3	9,7	PHC W124...
WH124	31,8	49,3	9,7	PHC WH124...

To complete designation add attachment spacing and type followed by chain length. For example PHCW78-L2R1X10FT (W78 chain with R-1 attachment on every second link, 10 feet chain length).

## W Series attachments

R-2, RR-2 attachments | W-1 attachments

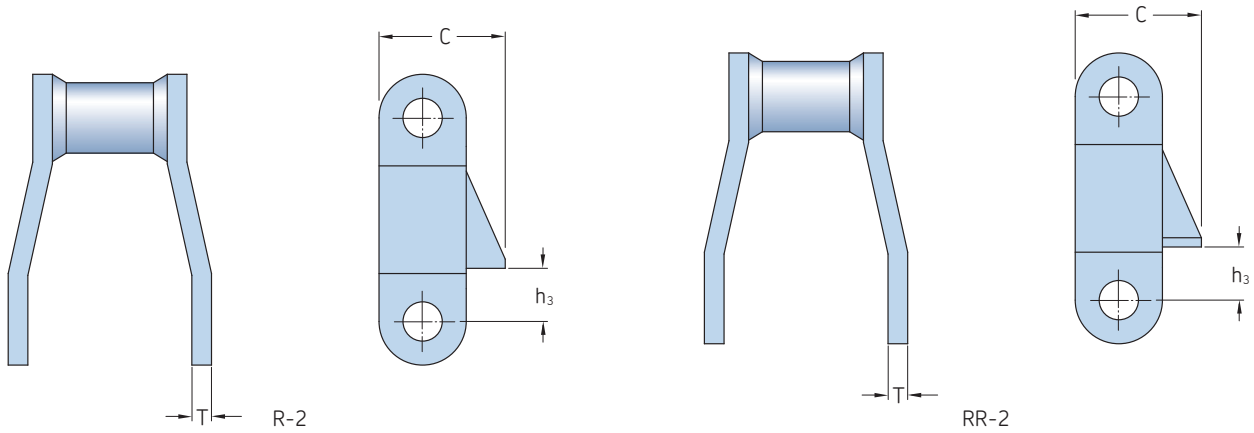

Chain number	Dimensions			Designation
	$h_3$	C	T	
-	mm	-	-	-
W78	17,3	41,1	6,4	PHC W78...
WH78	17,3	41,1	6,4	PHC WH78...
W82	22,4	49,3	6,4	PHC W82...
WH82	22,4	49,3	6,4	PHC WH82...
W124	31,8	49,3	9,7	PHC W124...
WH124	31,8	49,3	9,7	PHC WH124...

To complete designation add attachment spacing and type followed by chain length. For example PHC W78-L2R2X10FT (W78 chain with R-2 attachment on every second link, 10 feet chain length).

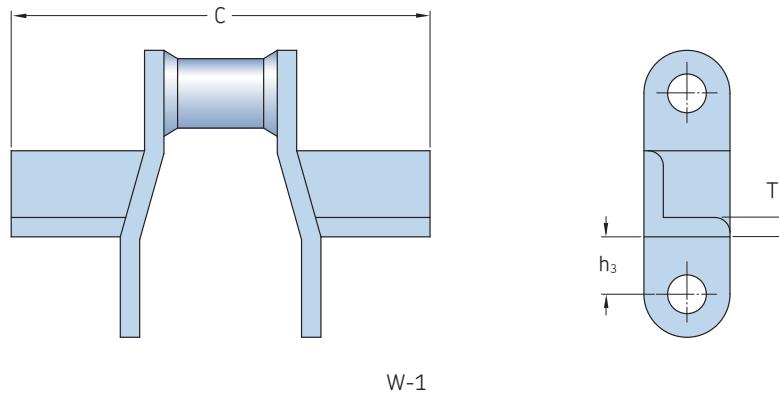

Chain number	Dimensions			Designation
	$h_3$	W	T	
-	mm	-	-	-
W78	19,1	153,9	6,4	PHC W78...
WH78	19,1	153,9	6,4	PHC WH78...
W82	23,9	166,6	6,4	PHC W82...
WH82	23,9	166,6	6,4	PHC WH82...
W124	30,0	217,4	6,4	PHC W124...
WH124	30,0	217,4	6,4	PHC WH124...
W124H	35,1	217,4	9,7	PHC W124H...
WH124H	35,1	217,4	9,7	PHC WH124H...
W132	38,1	316,0	9,7	PHC W132...
WH132	38,1	316,0	9,7	PHC WH132...

To complete designation add attachment spacing and type followed by chain length. For example PHC W78-L2W1X10FT (W78 chain with W-1 attachment on every second link, 10 feet chain length).

C Series  
C Series

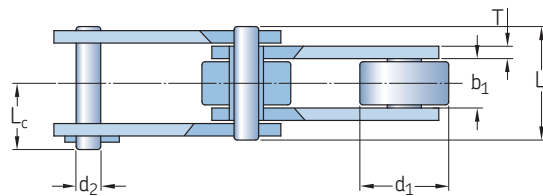
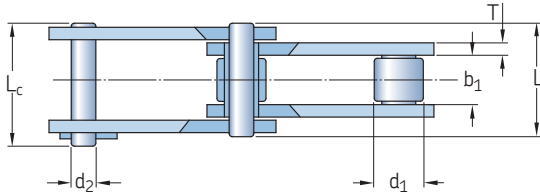
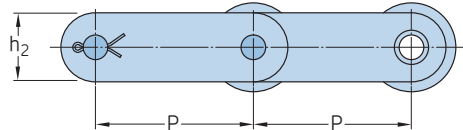
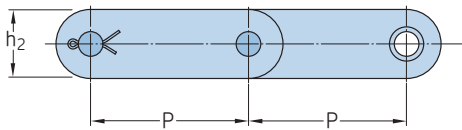

with small rollers

with large rollers

Chain number DIN/ISO	ANSI	Dimensions		Width between inner plates b <sub>1</sub> Min.	Pin diameter d <sub>2</sub> Max.	Pin length		Plate height h <sub>2</sub> Max.	Plate thickness T	Ultimate tensile strength Q <sub>0</sub> Min.	Average tensile strength Q <sub>0</sub>	Mass per meter q	Designation	
		Pitch P	Roller diameter d <sub>1</sub> Max.			L Max.	L Max.							
		mm												
-	-	-	-	-	-	-	-	-	-	-	-	-	-	
C208A	C2040	25,40	7,95	7,85	3,96	16,6	17,8	12,0	1,50	14,1	16,7	0,50	PHC C2040...	
C208AL	C2042	25,40	15,88	7,85	3,96	16,6	17,8	12,0	1,50	14,1	16,7	0,84	PHC C2042...	
C208AH	C2040H	25,40	7,95	7,85	3,96	18,8	19,9	12,0	2,03	14,1	17,2	0,65	PHC C2040H...	
C208AHL	C2042H	25,40	15,88	7,85	3,96	-	-	12,0	2,03	14,1	16,7	0,98	PHC C2042H...	
C208B	-	25,40	8,51	7,75	4,45	16,7	18,2	11,8	1,60	18,0	19,4	0,55	PHC C208B...	
C208BL	-	25,40	15,88	7,75	4,45	16,7	18,2	11,8	1,60	18,0	19,4	0,89	PHC C208BL...	
C210A	C2050	31,75	10,16	9,40	5,08	20,7	22,2	15,0	2,03	22,5	28,1	0,78	PHC C2050...	
C210AL	C2052	31,75	19,05	9,40	5,08	20,7	22,2	15,0	2,03	22,5	28,1	1,27	PHC C2052...	
C210AH	C2050H	31,75	10,16	9,40	5,08	-	-	15,0	2,42	22,1	28,1	1,05	PHC C2050H...	
C210AHL	C2052H	31,75	19,05	9,40	5,08	-	-	15,0	2,42	22,2	28,1	1,54	PHC C2052H...	
C210B	-	31,75	10,16	9,65	5,08	19,2	20,5	14,6	1,65	22,2	27,5	0,70	PHC C210B...	
C210BL	-	31,75	19,05	9,65	5,08	19,2	20,5	14,6	1,65	22,2	27,5	1,17	PHC C210BL...	
C212A	C2060	38,10	11,91	12,57	5,94	25,9	27,7	18,0	2,42	31,8	36,8	1,12	PHC C2060...	
C212AL	C2062	38,10	22,23	12,57	5,94	25,9	27,7	18,0	2,42	31,8	36,8	1,61	PHC C2062...	
C212AH	C2060H	38,10	11,91	12,57	5,94	29,2	31,6	18,0	3,25	31,8	41,6	1,44	PHC C2060H...	
C212AHL	C2062H	38,10	22,23	12,57	5,94	29,2	31,6	18,0	3,25	31,8	41,6	2,07	PHC C2062H...	
C212B	-	38,10	12,07	11,68	5,72	22,0	23,4	16,0	1,80	28,9	32,2	0,79	PHC C212B...	
C212BL	-	38,10	22,23	11,68	5,72	22,0	23,4	16,0	1,80	28,9	32,2	1,42	PHC C212BL...	
C216A	C2080	50,80	15,88	15,75	7,92	32,7	36,5	24,0	3,25	56,7	65,7	2,08	PHC C2080...	
C216AL	C2082	50,80	28,58	15,75	7,92	32,7	36,5	24,0	3,25	56,7	65,7	3,12	PHC C2082...	
C216AH	C2080H	50,80	15,88	15,75	7,92	36,2	39,4	24,0	4,00	56,7	70,0	2,54	PHC C2080H...	
C216AHL	C2082H	50,80	28,58	15,75	7,92	36,2	39,4	24,0	4,00	56,7	70,0	3,58	PHC C2082H...	
C216B	-	50,80	15,88	17,02	8,28	35,3	36,7	20,9	4,00	60,0	72,8	2,10	PHC C216B...	
C216BL	-	50,80	28,58	17,02	8,28	35,3	36,7	20,9	4,00	60,0	72,8	3,23	PHC C216BL...	
C220A	C2100	63,50	19,05	18,90	9,53	40,4	44,7	30,0	4,00	88,5	102,6	3,01	PHC C2100...	
C220AL	C2102	63,50	39,67	18,90	9,53	40,4	44,7	30,0	4,00	88,5	102,6	4,83	PHC C2102...	
C220AH	C2100H	63,50	19,05	18,90	9,53	43,6	46,9	30,0	4,80	88,5	112,4	3,56	PHC C2100H...	
C220AHL	C2102H	63,50	39,67	18,90	9,53	43,6	46,9	30,0	4,80	88,5	112,4	5,38	PHC C2102H...	
C220B	-	63,50	19,05	19,56	10,19	40,4	44,0	26,0	4,50	95,0	106,7	2,78	PHC C220B...	
C220BL	-	63,50	39,67	19,56	10,19	40,4	44,0	26,0	4,50	95,0	106,7	5,00	PHC C220BL...	
C224A	C2120	76,20	22,23	25,22	11,10	50,3	54,3	35,7	4,80	127,0	147,3	4,66	PHC C2120...	
C224AL	C2122	76,20	44,45	25,22	11,10	50,3	54,3	35,7	4,80	127,0	147,3	7,66	PHC C2122...	
C224AH	C2120H	76,20	22,23	25,22	11,10	53,5	57,5	35,7	5,60	127,0	160,9	5,26	PHC C2120H...	
C224AHL	C2122H	76,20	44,45	25,22	11,10	53,5	57,5	35,7	5,60	127,0	160,9	8,26	PHC C2122H...	
C224B	-	76,20	25,40	25,40	14,63	53,4	60,0	33,4	6,00	160,0	178,0	5,20	PHC C224B...	
C224BL	-	76,20	44,45	25,40	14,63	53,3	57,7	33,0	6,00	160,0	178,0	7,85	PHC C224BL...	
C228B	-	88,90	27,94	30,99	15,90	65,1	69,5	36,7	6,00	200,0	222,0	6,23	PHC C228B...	
C232A	C2160	101,60	25,58	31,75	14,27	64,8	69,6	47,8	6,40	226,8	278,9	8,15	PHC C2160...	
C232AL	C2162	101,60	57,15	31,75	14,27	64,8	69,6	47,8	6,40	226,8	278,9	13,00	PHC C2162...	
C232AH	C2160H	101,60	25,58	31,75	14,27	68,2	73,0	47,8	7,20	226,8	285,8	9,06	PHC C2160H...	
C232AHL	C2162H	101,60	57,15	31,75	14,27	68,2	73,0	47,8	7,20	226,8	285,8	13,84	PHC C2162H...	
C232B	-	101,60	29,21	30,99	17,81	66,0	71,0	42,0	6,00	250,0	277,5	6,72	PHC C232B...	

Standard lengths are 10 ft and 5 m. To complete designation add chain length. For example, to order C2040 in 10 ft length, use designation PHC C2040X10FT. For example, to order C2042 with 25,40 mm pitch with large roller in 10 ft. length, use designation C2042X10FT.

## C Series attachments

A-1, A-2, K-1, K-2 attachments

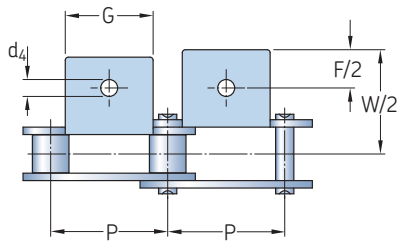

A-1

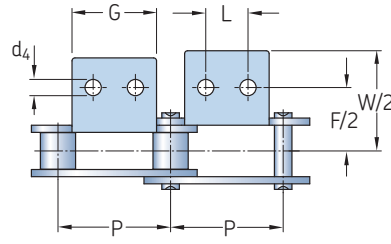
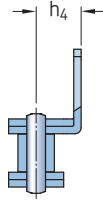

A-2

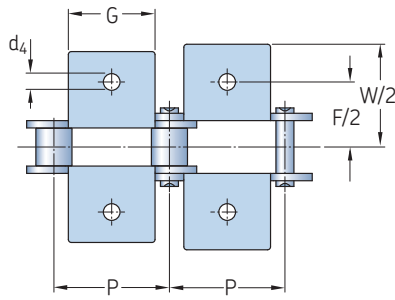
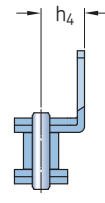

K-1

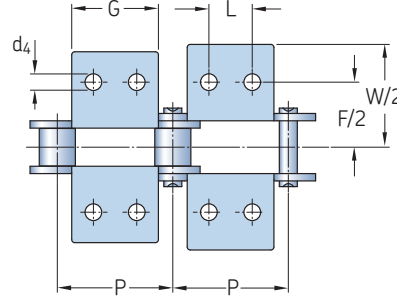
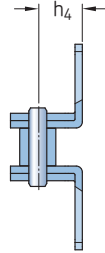

K-2

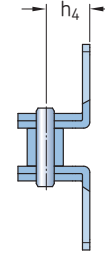

Chain number DIN/ISO	ANSI	Dimensions Pitch		L	F	W	h <sub>4</sub>	d <sub>4</sub>	Designation
		P	G						
		mm							
C208A	C2040	25,40	19,1	9,5	25,4	39,6	9,1	3,4	PHC C2040...
C208AL	C2042	25,40	19,1	9,5	25,4	-	-	-	PHC C2042...
C208B	-	25,40	23,2	12,7	25,4	39,6	9,1	4,5	PHC C208B...
C208BL	-	25,40	23,2	12,7	25,4	-	-	-	PHC C208BL...
C210A	C2050	31,75	23,8	11,9	31,8	49,0	11,1	5,5	PHC C2050...
C210AL	C2052	31,75	23,8	11,9	31,8	-	-	-	PHC C2052...
C212A	C2060	38,10	28,6	14,3	42,9	67,8	14,7	5,5	PHC C2060...
C212AL	C2062	38,10	28,6	14,3	42,9	-	-	-	PHC C2062...
C212AH	C2060H	38,10	28,6	14,3	42,9	67,8	14,7	5,5	PHC C2060H...
C212AHL	C2062H	38,10	28,6	14,3	42,9	-	-	-	PHC C2062H...
C216A	C2080	50,80	38,1	19,1	55,6	87,8	19,1	6,8	PHC C2080...
C216AL	C2082	50,80	38,1	19,1	55,6	-	-	-	PHC C2082...
C216AH	C2080H	50,80	38,1	19,1	55,6	87,8	19,1	6,8	PHC C2080H...
C216AHL	C2082H	50,80	38,1	19,1	55,6	-	-	-	PHC C2082H...
C220A	C2100	63,50	47,6	23,8	66,6	107,5	23,4	9,2	PHC C2100...
C220AL	C2102	63,50	47,6	23,8	66,6	-	-	-	PHC C2102...
C220AH	C2100H	63,50	47,6	23,8	66,6	107,5	23,4	9,2	PHC C2100H...
C220AHL	C2102H	63,50	47,6	23,8	66,6	-	-	-	PHC C2102H...
C224A	C2120	76,20	57,2	28,6	79,3	121,4	27,8	11,0	PHC C2120...
C224AL	C2122	76,20	57,2	28,6	79,3	121,4	27,8	11,0	PHC C2122...
C224AH	C2120H	76,20	57,2	28,6	79,3	121,4	27,8	11,0	PHC C2120H...
C224AHL	C2122H	76,20	57,2	28,6	79,3	121,4	27,8	11,0	PHC C2122H...
C232A	C2160	101,60	76,2	38,1	104,7	151,6	36,5	13,1	PHC C2160...
C232AL	C2162	101,60	76,2	38,1	104,7	151,6	36,5	13,1	PHC C2162...
C232AH	C2160H	101,60	76,2	38,1	104,7	151,6	36,5	13,1	PHC C2160H...
C232AHL	C2162H	101,60	76,2	38,1	104,7	151,6	36,5	13,1	PHC C2162H...

To complete designation add attachment spacing and type followed by chain length. For example PHC C2040-L2K1X10FT (C2040 chain with K-1 attachment on every second link, 10 feet chain length).

## C Series attachments

AA-1, AA-2, KK-1, KK-2 attachments

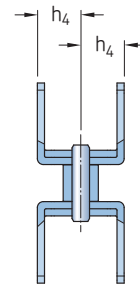
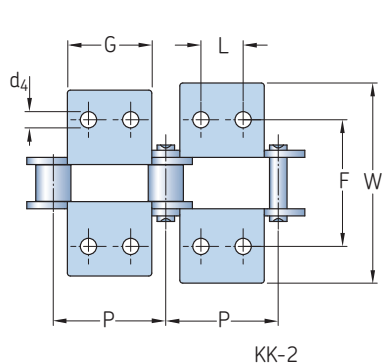
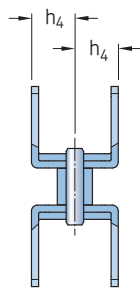
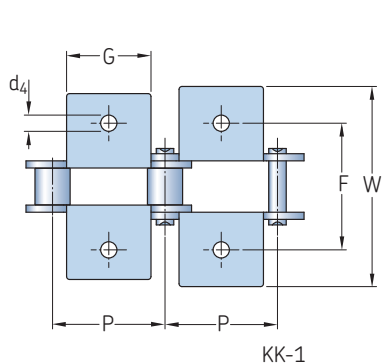
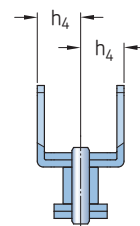
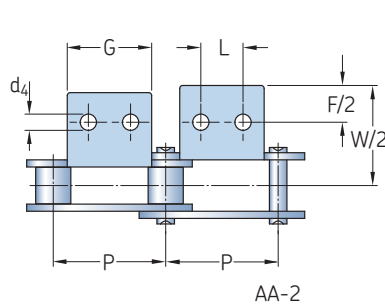
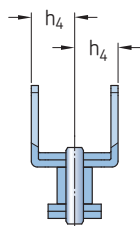
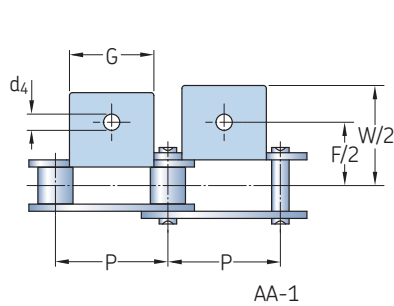

Chain number DIN/ISO	ANSI	Dimensions Pitch		L	F	W	h <sub>4</sub>	d <sub>4</sub>	Designation
		P	G						
-	-	mm		-	-	-	-	-	-
C208A	C2040	25,40	19,1	9,5	25,4	39,6	9,1	3,4	PHC C2040...
C208AL	C2042	25,40	19,1	9,5	25,4	39,6	9,1	3,4	PHC C2042...
C208B	-	25,40	23,2	12,7	25,4	39,6	9,1	4,5	PHC C208B...
C208BL	-	25,40	23,2	12,7	25,4	39,6	9,1	4,5	PHC C208BL...
C210A	C2050	31,75	23,8	11,9	31,8	49,0	11,1	5,5	PHC C2050...
C210AL	C2052	31,75	23,8	11,9	31,8	49,0	11,1	5,5	PHC C2052...
C212A	C2060	38,10	28,6	14,3	42,9	67,8	14,7	5,5	PHC C2060...
C212AL	C2062	38,10	28,6	14,3	42,9	67,8	14,7	5,5	PHC C2062...
C212AH	C2060H	38,10	28,6	14,3	42,9	67,8	14,7	5,5	PHC C2060H...
C212AHL	C2062H	38,10	28,6	14,3	42,9	67,8	14,7	5,5	PHC C2062H...
C216A	C2080	50,80	38,1	19,1	55,6	87,8	19,1	6,8	PHC C2080...
C216AL	C2082	50,80	38,1	19,1	55,6	87,8	19,1	6,8	PHC C2082...
C216AH	C2080H	50,80	38,1	19,1	55,6	87,8	19,1	6,8	PHC C2080H...
C216AHL	C2082H	50,80	38,1	19,1	55,6	87,8	19,1	6,8	PHC C2082H...

To complete designation add attachment spacing and type followed by chain length. For example PHC C2040-L2KK1X10FT (C2040 chain with KK-1 attachment on every second link, 10 feet chain length).

## C Series attachments

SA-1, SA-2, SK-1, SK-2 attachments

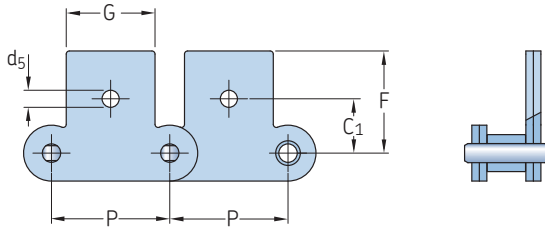

SA-1

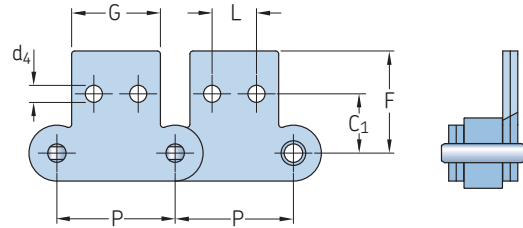

SA-2

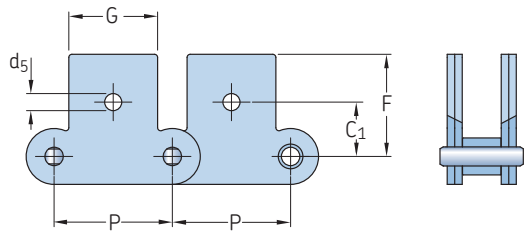

SK-1

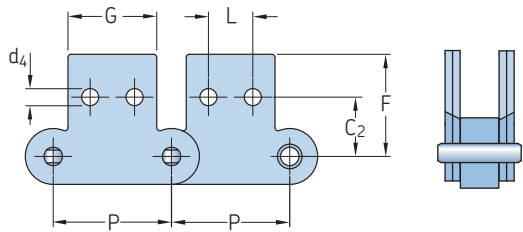

SK-2

Chain number DIN/ISO	ANSI	Dimensions Pitch								Designation
		P	G	L	C <sub>1</sub>	C <sub>2</sub>	F	d <sub>4</sub>	d <sub>5</sub>	
-		mm								-
C208A	C2040	25,40	19,1	9,5	11,1	13,5	20,5	3,4	5,5	PHC C2040...
C208AL	C2042	25,40	19,1	9,5	11,1	13,5	20,5	3,4	5,5	PHC C2042...
C208B	-	25,40	23,2	12,7	11,1	13,5	20,5	4,5	5,5	PHC C208B...
C208BL	-	25,40	23,2	12,7	11,1	13,5	20,5	4,5	5,5	PHC C208BL...
C210A	C2050	31,75	23,8	11,9	14,3	15,9	31,8	5,5	6,6	PHC C2050...
C210AL	C2052	31,75	23,8	11,9	14,3	15,9	31,8	5,5	6,6	PHC C2052...
C212A	C2060	38,10	28,6	14,3	17,5	19,1	32,9	5,5	9,2	PHC C2060...
C212AL	C2062	38,10	28,6	14,3	17,5	19,1	32,9	5,5	9,2	PHC C2062...
C212AH	C2060H	38,10	28,6	14,3	17,5	19,1	32,9	5,5	9,2	PHC C2060H...
C212AHL	C2062H	38,10	28,6	14,3	17,5	19,1	32,9	5,5	9,2	PHC C2062H...
C216A	C2080	50,80	38,1	19,1	22,2	25,4	43,5	6,6	11,0	PHC C2080...
C216AL	C2082	50,80	38,1	19,1	22,2	25,4	43,5	6,6	11,0	PHC C2082...
C216AH	C2080H	50,80	38,1	19,1	22,2	25,4	43,5	6,6	11,0	PHC C2080H...
C216AHL	C2082H	50,80	38,1	19,1	22,2	25,4	43,5	6,6	11,0	PHC C2082H...
C220A	C2100	63,50	47,6	23,8	28,6	31,8	50,4	8,4	13,0	PHC C2100...
C220AL	C2102	63,50	47,6	23,8	28,6	31,8	50,4	8,4	13,0	PHC C2102...
C220AH	C2100H	63,50	47,6	23,8	28,6	31,8	50,4	8,4	13,0	PHC C2100H...
C220AHL	C2102H	63,50	47,6	23,8	28,6	31,8	50,4	8,4	13,0	PHC C2102H...

To complete designation add attachment spacing and type followed by chain length. For example PHC C2040-L2SK1X10FT (C2040 chain with SK-1 attachment on every second link, 10 feet chain length).



## C Series attachments

SAA-1, SAA-2, SKK-1, SKK-2 attachments

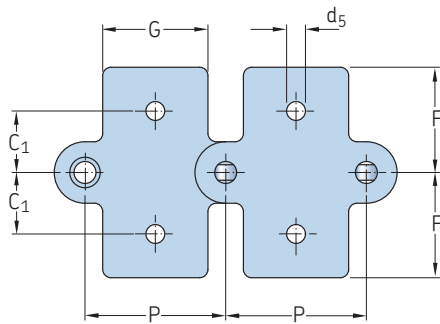

SAA-1

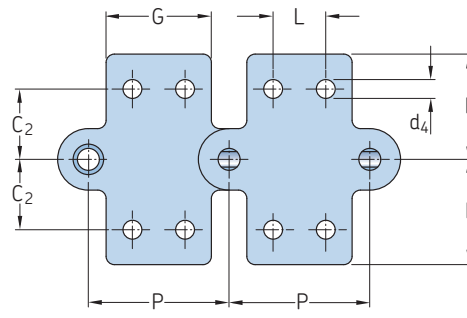

SAA-2

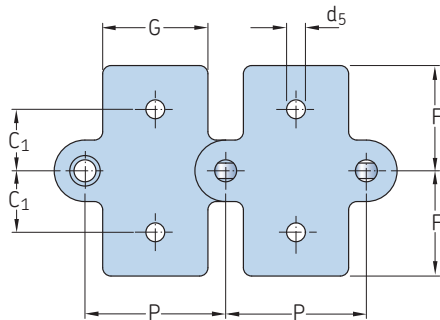

SKK-1

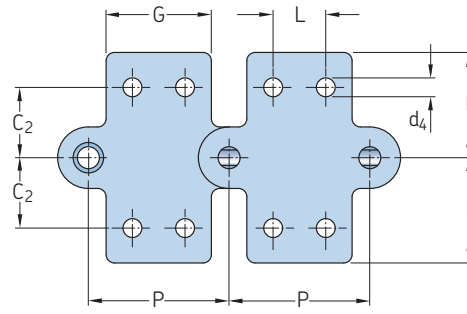

SKK-2

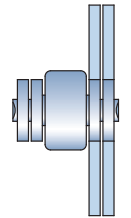

2

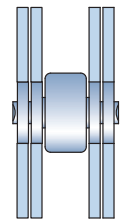

Chain number DIN/ISO	ANSI	Dimensions Pitch								Designation
		P	G	L	C <sub>1</sub>	C <sub>2</sub>	F	d <sub>4</sub>	d <sub>5</sub>	
-	-	mm								-
C208A	C2040	25,40	19,1	9,5	11,1	13,5	20,5	3,4	5,5	PHC C2040...
C208AL	C2042	25,40	19,1	9,5	11,1	13,5	20,5	3,4	5,5	PHC C2042...
C208B	-	25,40	23,2	12,7	11,1	13,5	20,5	4,5	5,5	PHC C208B...
C208BL	-	25,40	23,2	12,7	11,1	13,5	20,5	4,5	5,5	PHC C208BL...
C210A	C2050	31,75	23,8	11,9	14,3	15,9	31,8	5,5	6,6	PHC C2050...
C210AL	C2052	31,75	23,8	11,9	14,3	15,9	31,8	5,5	6,6	PHC C2052...
C212A	C2060	38,10	28,6	14,3	17,5	19,1	32,9	5,5	9,2	PHC C2060...
C212AL	C2062	38,10	28,6	14,3	17,5	19,1	32,9	5,5	9,2	PHC C2062...
C212AH	C2060H	38,10	28,6	14,3	17,5	19,1	32,9	5,5	9,2	PHC C2060H...
C212AHL	C2062H	38,10	28,6	14,3	17,5	19,1	32,9	5,5	9,2	PHC C2062H...
C216A	C2080	50,80	38,1	19,1	22,2	25,4	43,5	6,6	11,0	PHC C2080...
C216AL	C2082	50,80	38,1	19,1	22,2	25,4	43,5	6,6	11,0	PHC C2082...
C216AH	C2080H	50,80	38,1	19,1	22,2	25,4	43,5	6,6	11,0	PHC C2080H...
C216AHL	C2082H	50,80	38,1	19,1	22,2	25,4	43,5	6,6	11,0	PHC C2082H...

To complete designation add attachment spacing and type followed by chain length. For example PHC C2040-L2SKK1X10FT (C2040 chain with SKK-1 attachment on every second link, 10 feet chain length).

## C Series attachments

### GK-1 attachments

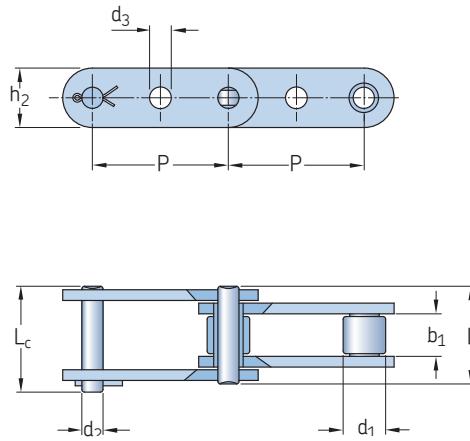

Chain number DIN/ISO	ANSI	Dimensions						Designation
		Pitch P	b <sub>1</sub>	d <sub>2</sub>	d <sub>3</sub>	L	L <sub>c</sub>	
		mm						
C208A	C2040	25,40	7,85	3,96	4,1	16,6	18,8	PHC C2040...
C208AL	C2042	25,40	7,85	3,96	4,1	16,6	18,8	PHC C2042...
C210A	C2050	31,75	9,40	5,08	5,1	20,7	23,3	PHC C2050...
C210AL	C2052	31,75	9,40	5,08	5,1	20,7	23,3	PHC C2052...
C212A	C2060	38,10	12,57	5,94	6,1	25,9	28,3	PHC C2060...
C212AL	C2062	38,10	12,57	5,94	6,1	25,9	28,3	PHC C2062...
C212AH	C2060H	38,10	12,57	5,94	6,1	29,2	31,6	PHC C2060H...
C212AHL	C2062H	38,10	12,57	5,94	6,1	29,2	31,6	PHC C2062H...
C216A	C2080	50,80	15,75	7,92	8,1	32,7	36,5	PHC C2080...
C216AL	C2082	50,80	15,75	7,92	8,1	32,7	36,5	PHC C2082...
C216AH	C2080H	50,80	15,75	7,92	8,1	36,2	39,4	PHC C2080H...
C216AHL	C2082H	50,80	15,75	7,92	8,1	36,2	39,4	PHC C2082H...
C220A	C2100	63,50	18,90	9,53	10,1	40,4	44,7	PHC C2100...
C220AL	C2102	63,50	18,90	9,53	10,1	40,4	44,7	PHC C2102...
C220AH	C2100H	63,50	18,90	9,53	10,1	43,6	46,9	PHC C2100H...
C220AHL	C2102H	63,50	18,90	9,53	10,1	43,6	46,9	PHC C2102H...

To complete designation add attachment spacing and type followed by chain length. For example PHC C2040-L2GK1X10FT (C2040 chain with GK-1 attachment on every second link, 10 feet chain length).

## C Series attachments

### D-3, D-1 attachments

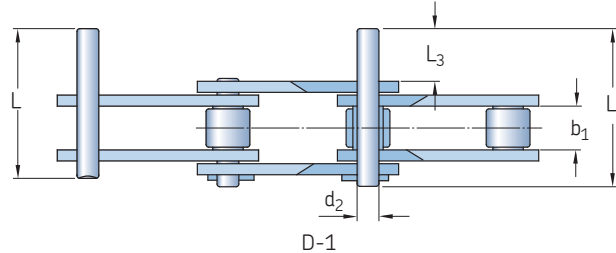
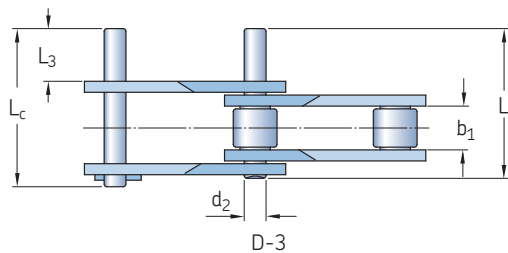
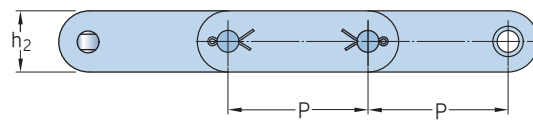
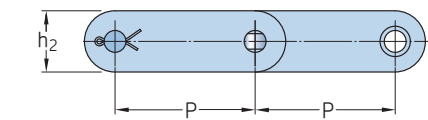

Chain number DIN/ISO	ANSI	Dimensions Pitch			Designation			
		P	b <sub>1</sub>	d <sub>2</sub>	L <sub>3</sub>	L	L <sub>c</sub>	
		mm						
C208A	C2040	25,40	7,85	3,96	9,5	25,1	26,2	PHC C2040...
C208AL	C2042	25,40	7,85	3,96	9,5	25,1	26,2	PHC C2042...
C210A	C2050	31,75	9,40	5,08	11,9	31,3	33,1	PHC C2050...
C210AL	C2052	31,75	9,40	5,08	11,9	31,3	33,1	PHC C2052...
C212A	C2060	38,10	12,57	5,94	14,3	38,6	40,6	PHC C2060...
C212AL	C2062	38,10	12,57	5,94	14,3	38,6	40,6	PHC C2062...
C212AH	C2060H	38,10	12,57	5,94	14,3	42,0	43,8	PHC C2060H...
C212AHL	C2062H	38,10	12,57	5,94	14,3	42,0	43,8	PHC C2062H...
C216A	C2080	50,80	15,75	7,92	19,1	50,3	53,3	PHC C2080...
C216AL	C2082	50,80	15,75	7,92	19,1	50,3	53,3	PHC C2082...
C216AH	C2080H	50,80	15,75	7,92	19,1	53,5	55,0	PHC C2080H...
C216AHL	C2082H	50,80	15,75	7,92	19,1	53,5	55,0	PHC C2082H...
C220A	C2100	63,50	18,90	9,53	23,8	61,8	66,1	PHC C2100...
C220AL	C2102	63,50	18,90	9,53	23,8	61,8	66,1	PHC C2102...
C220AH	C2100H	63,50	18,90	9,53	23,8	65,0	68,3	PHC C2100H...
C220AHL	C2102H	63,50	18,90	9,53	23,8	65,0	68,3	PHC C2102H...
C224AH	C2120H	76,20	25,22	11,10	28,6	79,6	83,6	PHC C2120H...
C224AHL	C2122H	76,20	25,22	11,10	28,6	79,6	83,6	PHC C2122H...
C232AH	C2160H	101,60	31,75	14,27	38,1	103,0	107,8	PHC C2160H...
C232AHL	C2162H	101,60	31,75	14,27	38,1	103,0	107,8	PHC C2162H...

To complete designation add attachment spacing and type followed by chain length. For example PHC C2040-L2D1X10FT (C2040 chain with D-1 attachment on every second link, 10 feet chain length).

## Lumber mill series

Lumber mill series | 3939 series

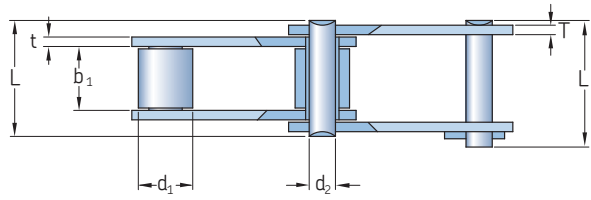
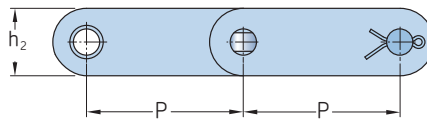

Lumber mill

Chain number	Dimensions		Width between inner plates b <sub>1</sub> Min.	Pin diameter d <sub>2</sub> Max.	Pin length		Plate height h <sub>2</sub> Max.	Plate thickness T Max.	Ultimate tensile strength Q Min.	Average tensile strength Q <sub>0</sub>	Mass per meter q	Designation			
	Pitch P	Roller diameter d <sub>1</sub> Max.			L Max.	L <sub>c</sub> Max.									
–												mm	kN	Kg/m	–
81X	66,27	23,0	27,00	11,10	49,0	53,5	28,50	4,00	106,7	128,9	3,78	PHC 81X...			
81XH	66,27	23,0	27,78	11,10	60,7	65,1	31,35	5,55	151,9	175,7	5,88	PHC 81XH...			
81XHH	66,27	23,0	27,78	11,10	65,6	70,0	31,35	7,94	191,1	212,6	6,70	PHC 81XHH...			
81XHS	66,27	23,0	27,00	11,10	63,6	68,0	31,80	7,60	152,0	177,2	6,55	PHC 81XHS...			
500R	50,00	25,4	25,40	14,63	52,0	56,4	40,00	5,00	100,0	114,5	7,13	PHC 500R...			
441.100R	100,00	25,4	25,40	14,63	52,0	56,4	40,00	5,00	100,0	114,5	5,15	PHC 441.100R...			
3939	203,20	23,0	27,00	11,10	49,0	53,5	28,58	4,00	115,6	136,5	2,45	PHC 3939...			

Standard lengths are 10 ft and 5 m. To complete designation add chain length. For example, to order 81X in 10 ft length, use designation PHC 81XX10FT.

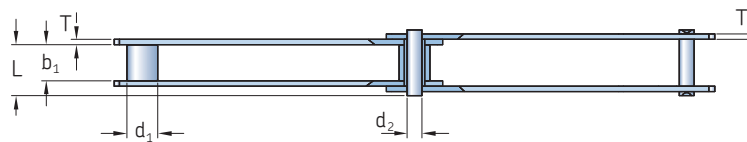
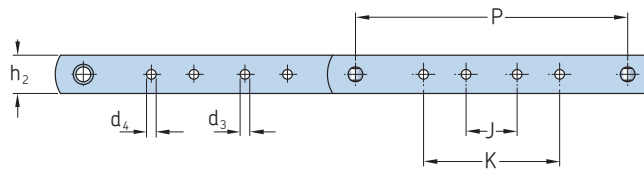

3939 series

Chain number	Dimensions		Width between inner plates b <sub>1</sub> Min.	Pin diameter d <sub>2</sub> Max.	Pin length L Max.	Plate height h <sub>2</sub> Max.	Plate thickness T Max.	Other plate dimensions				Ultimate tensile strength Q Min.	Average tensile strength Q <sub>0</sub>	Mass per meter q	Designation				
	Pitch P	Roller diameter d <sub>1</sub> Max.						d <sub>3</sub> Max.	d <sub>4</sub> Max.	J Max.	K Max.								
–																mm	kN	Kg/m	–
3939-B4	203,2	23	27	11,1	49	28,58	4	7,2	7,2	38,1	101,6	115,6	136,5	2,45	PHC 3939-B4...				
3939-B21	203,2	23	27	11,1	49	28,58	4	7,2	–	38,1	–	115,6	136,5	2,45	PHC 3939-B21...				
3939-B23	203,2	23	27	11,1	49	28,58	4	–	10,3	–	92,1	115,6	136,5	2,45	PHC 3939-B23...				
3939-B24	203,2	23	27	11,1	49	28,58	4	–	7,2	–	101,6	115,6	136,5	2,48	PHC 3939-B24...				
3939-B40	203,2	23	27	11,1	49	28,58	4	–	10,3	–	101,6	115,6	136,5	2,45	PHC 3939-B40...				
3939-B43	203,2	23	27	11,1	49	28,58	4	7,2	10,3	38,1	92,1	115,6	136,5	2,42	PHC 3939-B43...				
3939-B44	203,2	23	27	11,1	49	28,58	4	7,2	10,3	38,1	101,6	115,6	136,5	2,45	PHC 3939-B44...				

Standard lengths are 10 ft and 5 m. To complete designation add chain length. For example, to order 3939-B4 in 10 ft length, use designation PHC 3939-B4X10FT.

## Steel pintle series

### Steel pintle

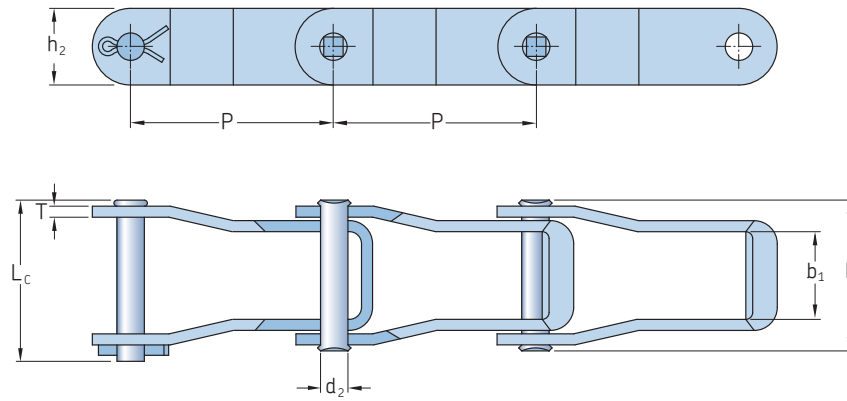

Chain number	Dimensions		Pin diameter	Pin length		Plate height	Plate thickness	Ultimate tensile strength	Average tensile strength	Mass per meter	Designation	
	Pitch	Width between inner plates		L	L <sub>c</sub>							Q
	P	b <sub>1</sub> Max.	d <sub>2</sub> Max.	L Max.	L <sub>c</sub> Max.	h <sub>2</sub> Max.	T	Min.	Min.			
	mm											
								kN			Kg/m	
662	42,27	22,9	7,19	41,2	44,2	18,8	3,2	37,80	41,5	1,63	PHC 662...	
667H	58,75	25,4	7,94	43,7	46,7	22,2	3,2	42,30	46,5	1,87	PHC 667H...	
667X	57,15	26,6	11,10	50,2	55,0	23,8	4,3	66,70	73,3	2,98	PHC 667X...	
667XH	57,15	27,4	11,91	58,0	62,0	27,3	5,7	124,50	136,9	4,34	PHC 667XH...	
667K	57,15	27,4	11,10	55,5	60,0	27,3	5,1	89,00	97,9	3,91	PHC 667K...	
667J	57,15	26,6	9,53	50,2	55,0	27,3	4,3	62,28	68,5	2,81	PHC 667J...	
88K	66,27	27,4	11,10	55,5	60,0	27,3	5,1	89,00	97,9	3,73	PHC 88K...	
88C	66,27	31,4	12,70	64,6	69,0	28,9	6,4	133,36	146,6	5,17	PHC 88C...	

Standard lengths are 10 ft and 5 m. To complete designation add chain length. For example, to order 662 in 10 ft length, use designation PHC 662X10FT.

**Steel pintle attachments**  
 C-1 attachments | AS attachments

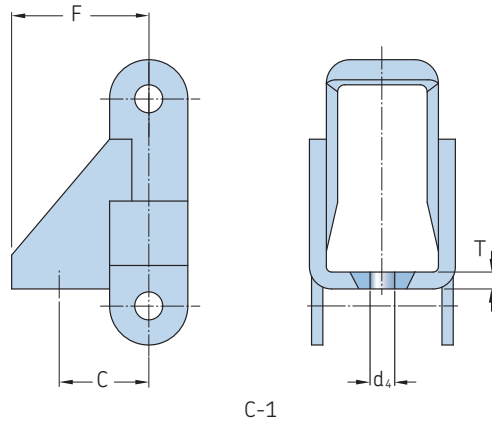

C-1

Chain number	Dimensions					Designation
	C	F	d <sub>4</sub>	T		
-	mm					-
662	22,9	37,2	7	2,8	PHC 662...	
667H	25,4	38,9	7	4,8	PHC 667H...	
667X	29,5	39,7	7	4,8	PHC 667X...	

To complete designation add attachment spacing and type followed by chain length. For example PHC 662-L2C1X10FT (662 chain with C-1 attachment on every second link, 10 feet chain length).

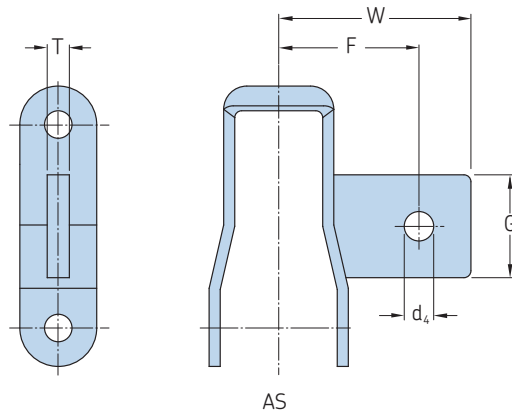

AS

Chain number	Dimensions						Designation
	G	F	W	d <sub>4</sub>	T		
-	mm						-
662	24,2	35,9	48,4	7,0	4,3	PHC 662...	
667H	29,7	51,6	66,6	8,5	6,4	PHC 667H...	
667X	29,7	51,6	69,0	8,5	7,9	PHC 667X...	
667K	32,5	51,6	72,2	10,0	9,5	PHC 667K...	
88K	32,5	51,6	72,2	10,0	9,5	PHC 88K...	

To complete designation add attachment spacing and type followed by chain length. For example PHC 662-L2ASX10FT (662 chain with AS attachment on every second link, 10 feet chain length).

## Steel pintle attachments

A-22 attachments | AN attachments

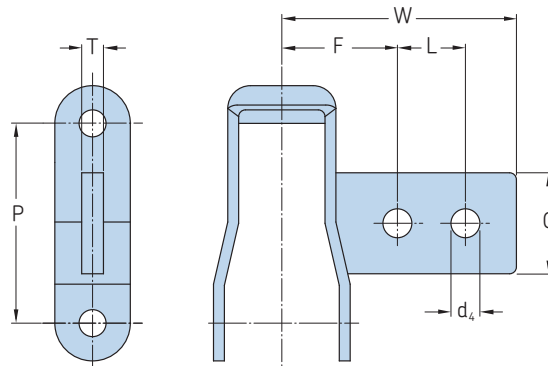

A-22

Chain number	Dimensions							Designation
	Pitch							
	P	G	F	L	W	d <sub>4</sub>	T	
-	mm							-
662	42,27	24,4	34,9	15,9	60,3	6,75	4,3	PHC 662...
88C	66,27	32,5	54,0	63,5	136,5	9,92	9,5	PHC 88C...
88K	66,27	32,5	54,0	63,5	136,5	9,92	9,5	PHC 88K...

To complete designation add attachment spacing and type followed by chain length. For example PHC 662-L2A22X10FT (662 chain with A-22 attachment on every second link, 10 feet chain length).

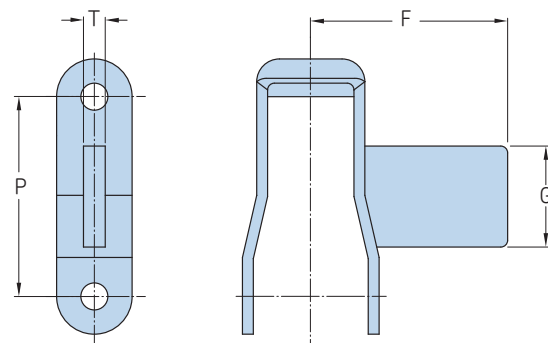

AN

Chain number	Dimensions				Designation
	Pitch				
	P	G	F	T	
-	mm				-
662	42,27	24,2	47,6	4,3	PHC 662...
667H	58,75	29,7	69,0	6,4	PHC 667H...
667X	57,15	29,7	68,3	7,9	PHC 667X...
667K	57,15	32,5	68,3	9,5	PHC 667K...
88K	66,27	32,5	68,3	9,5	PHC 88K...

To complete designation add attachment spacing and type followed by chain length. For example PHC 662-L2ANX10FT (662 chain with AN attachment on every second link, 10 feet chain length).

## Steel pintle attachments

G attachments | K-1 (K-1 and K-19) attachments

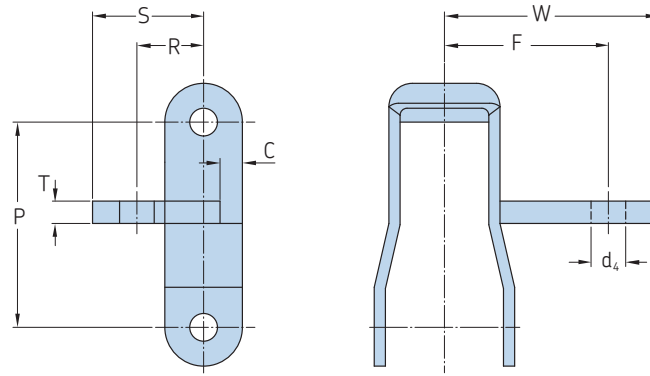

G

Chain number	Attachment number	Dimensions								Designation
		Pitch	R	S	F	W	d <sub>4</sub>	T	C	
		mm								
662	G28	42,27	20,6	33,3	31,8	43,7	6,75	6,4	4,8	PHC 662...
662	G30	42,27	19,1	33,3	33,3	48,0	8,33	6,4	4,8	PHC 662...
662	G30S	42,27	19,1	33,3	33,3	48,0	8,73	6,4	4,8	PHC 662...
667H	G27S	58,75	19,1	31,8	51,6	65,9	9,92	6,4	6,4	PHC 667H...

To complete designation add attachment spacing and type followed by chain length. For example PHC 662-L2G28X10FT (662 chain with G28 attachment on every second link, 10 feet chain length).

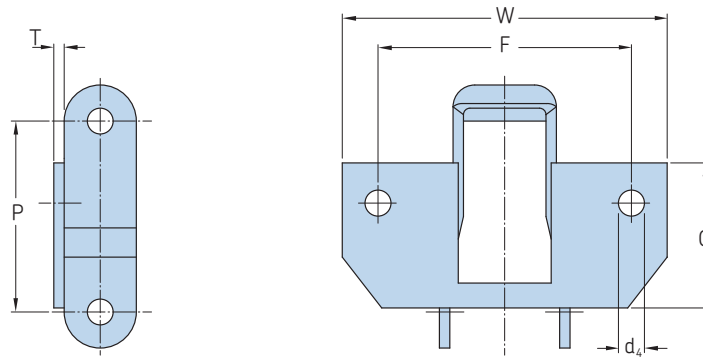

K-1 (K-1 and K-19)

Chain number	Attachment number	Dimensions						Designation
		Pitch	G	F	W	d <sub>4</sub>	T	
		mm						
662	K1	42,27	34,9	62,7	82,6	6,75	3,2	PHC 662...
662	K19	42,27	34,9	50,8	71,4	6,75	3,2	PHC 662...
667X	K1	57,15	34,9	62,7	82,6	6,75	3,2	PHC 667X...
667H	K1	58,75	34,9	62,7	82,6	6,75	3,2	PHC 667H...

To complete designation add attachment spacing and type followed by chain length. For example PHC 662-L2K1X10FT (662 chain with K1 attachment on every second link, 10 feet chain length).



## Steel pintle attachments

K-1 (K-2C, K-2M, K-2P) attachments | (K-1C, K-1M, K-1P) attachments

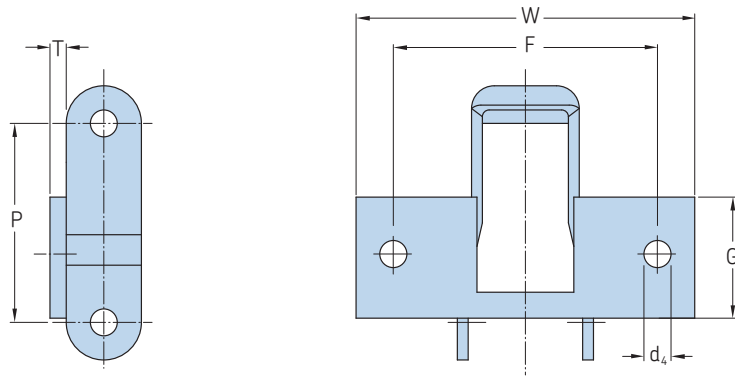

K-1 (K-1C, K-1M, K-1P)

Chain number	Attachment number	Dimensions						Designation
		Pitch	P	G	F	W	d <sub>4</sub>	
		mm						
88K	K1C	66,27	47,6	95,3	127	9,92	4,8	PHC 88K...
88K	K1M	66,27	47,6	101,6	127	9,92	4,8	PHC 88K...
88K	K1P	66,27	47,6	96,8	127	9,92	4,8	PHC 88K...

To complete designation add attachment spacing and type followed by chain length. For example PHC 88K-L2K1CX10FT (88K chain with K1C attachment on every second link, 10 feet chain length).

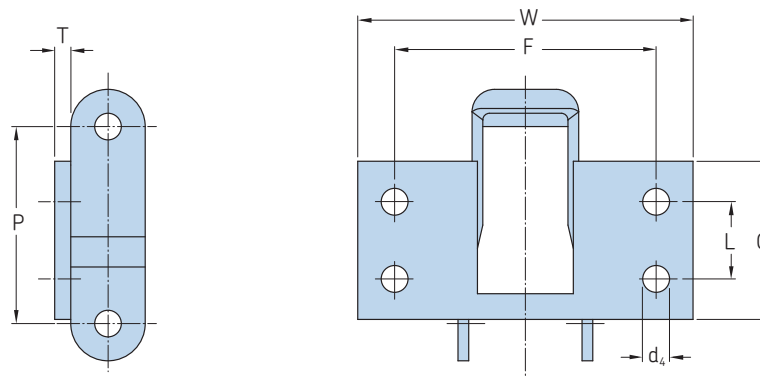

K-2 (K-2C, K-2M, K-2P)

Chain number	Attachment number	Dimensions							Designation
		Pitch	P	L	G	F	W	d <sub>4</sub>	
		mm							
88K	K2C	66,27	31,8	57,2	106,4	127	9,92	4,8	PHC 88K...
88K	K2M	66,27	31,8	57,2	101,6	127	9,92	4,8	PHC 88K...
88K	K2P	66,27	31,8	57,2	92,0	127	9,92	4,8	PHC 88K...

To complete designation add attachment spacing and type followed by chain length. For example PHC 88K-L2K2CX10FT (88K chain with K2C attachment on every second link, 10 feet chain length).

**Steel mill series**  
P500 | P500F1

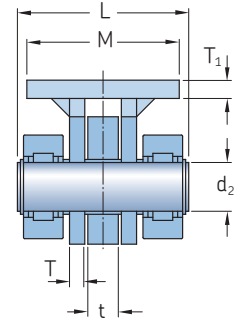
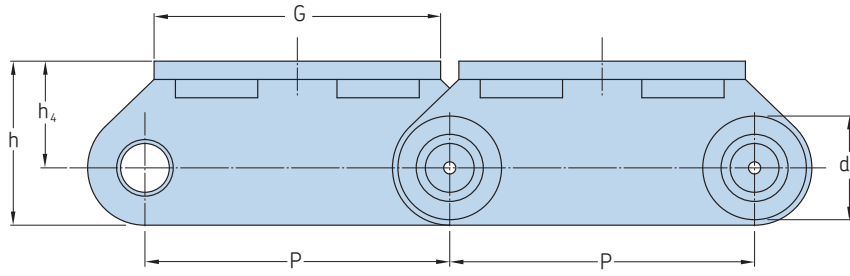

P500

Chain number	Dimensions							Attachment dimensions				Ultimate tensile strength Q Min.	Designation
	Pitch P	Roller diameter d <sub>1</sub> Max.	Pin diameter d <sub>2</sub> Max.	Pin length L Max.	Plate thickness t Max.	T Max.	G	M	h <sub>4</sub>	h	T <sub>1</sub>		
-	mm											kN	-
<b>P500</b>	500	170	80	281	50,0	25	470	250	175	269	30	1 900	<b>PHC P500...</b>

Standard lengths are 10 ft and 5 m. To complete designation add chain length. For example, to order P500 in 10 ft length, use designation PHC P500X10FT.

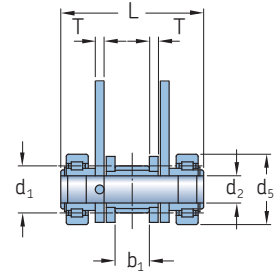
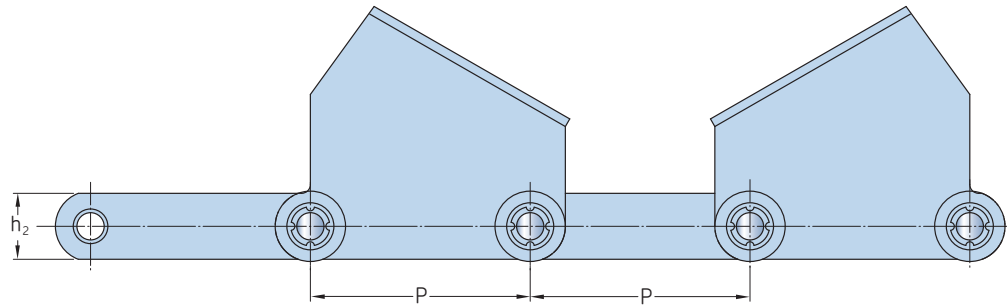

P500F1

Chain number	Dimensions				Pin diameter d <sub>2</sub> Max.	Pin length L Max.	Plate thickness T Max.	Plate height h <sub>2</sub> Max.	Ultimate tensile strength Q Min.	Designation
	Pitch P	Roller diameter d <sub>1</sub> Max.	d <sub>5</sub> Max.	Width between inner plates b <sub>1</sub> Min.						
-	mm								kN	-
<b>P500F1</b>	500	107	160	78	62	325	20	150	800	<b>PHC P500F1...</b>

Standard lengths are 10 ft and 5 m. To complete designation add chain length. For example, to order P500F1 in 10 ft length, use designation PHC P500F1X10FT.

Steel mill series  
P650 | P500F2

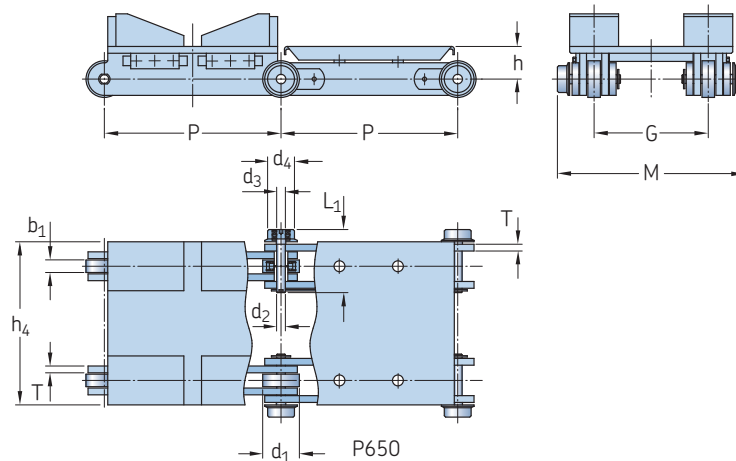

Chain number	Dimensions		Roller diameter		Width between inner plates		Pin diameter		Pin length L Max.	Plate thickness T Max.	Attachment dimensions				Ultimate tensile strength Q Min.	Mass per meter q	Designation
	Pitch P		d <sub>1</sub> Max.	d <sub>4</sub> Max.	b <sub>1</sub> Min.	d <sub>2</sub> Max.	d <sub>3</sub> Max.	G			M	h <sub>4</sub>	h				
-	mm													kN	Kg/m	-	
<b>P650</b>	650		135	85	56	32	35	232	25	420	690	600	120	750	214,5	<b>PHC P500...</b>	

Standard lengths are 10 ft and 5 m. To complete designation add chain length. For example, to order P650 in 10 ft length, use designation PHC P650X10FT.

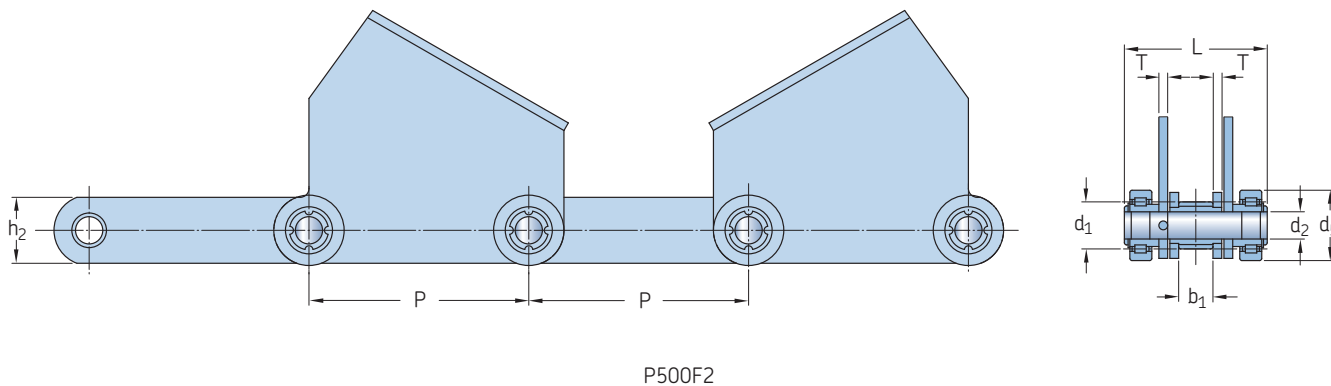

Chain number	Dimensions		Roller diameter		Width between inner plates		Pin diameter d <sub>2</sub> Max.	Pin length L Max.	Plate height h <sub>2</sub> Max.	Plate thickness T Max.	Ultimate tensile strength Q Min.	Designation
	Pitch P		d <sub>1</sub> Max.	d <sub>5</sub> Max.	b <sub>1</sub> Min.							
-	mm										kN	-
<b>P500F2</b>	500		107	160	76	62	310	150	16	700	<b>PHC P500F2...</b>	

Standard lengths are 10 ft and 5 m. To complete designation add chain length. For example, to order P500F2 in 10 ft length, use designation PHC 500F2X10FT.

Steel mill series  
P600F1

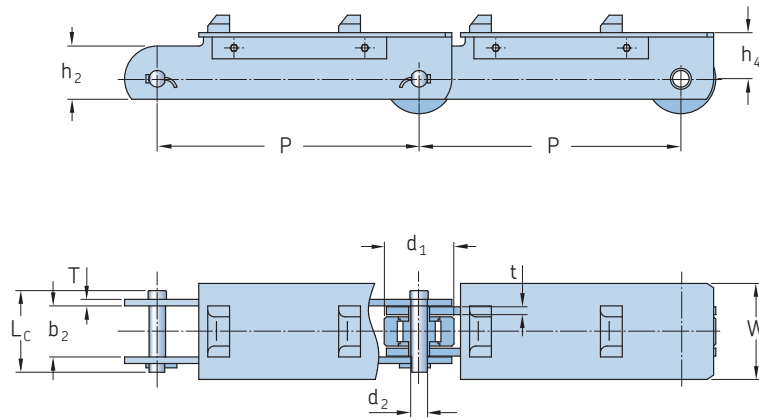

Chain number	Dimensions		Roller diameter $d_1$ Max.	Width between outer plates $b_2$ Min.	Pin diameter $d_2$ Max.	Pin length $L_c$ Max.	Plate height $h_2$ Max.	Plate thickness		Attachment dimensions		Average tensile strength $Q_s$ Min.	Designation
	Pitch P							t Max.	T Max.	$h_4$	W		
-	mm											kN	-
P600F1	600		150	117	38	187	122	18	15	106	220	1 470	PHC P600F1...

Standard lengths are 10 ft and 5 m. To complete designation add chain length. For example, to order P600F1 in 10 ft length, use designation PHC 600F1X10FT.

Steel mill series  
P625

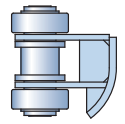
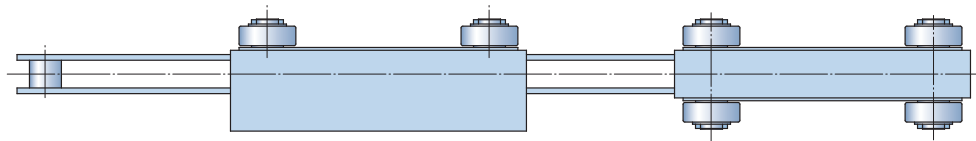
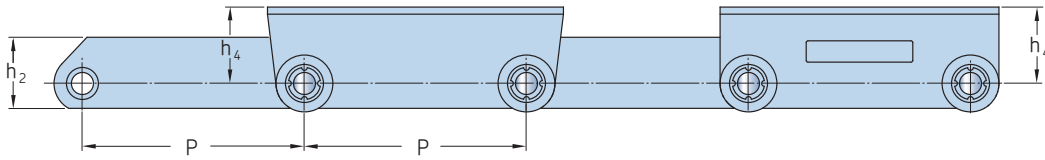

Right hand

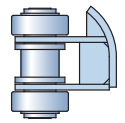
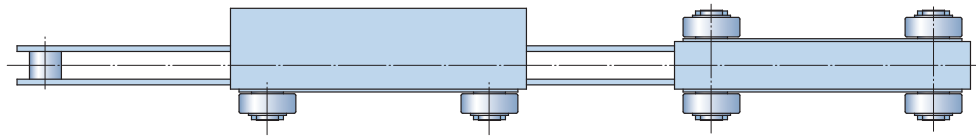

Left hand

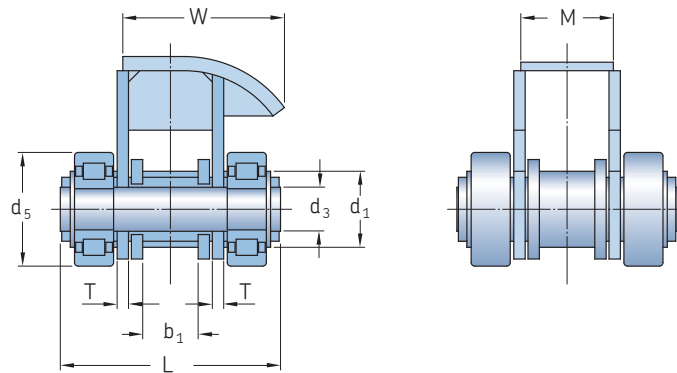

Chain number	Dimensions		Roller diameter $d_1$ Max.	$d_5$ Max.	Width between inner plates $b_1$ Min.	Pin diameter $d_3$ Max.	Pin length $L$ Max.	Plate thickness $T$ Max.	Attachment dimensions				Ultimate tensile strength $Q$ Min.	Designation
	Pitch $P$								$W$	$M$	$h_2$	$h_4$		
-	mm												kN	-
P625	625	107	160	78	62	310	16	228	130	200	215	700	PHC P625...	

Standard lengths are 10 ft and 5 m. To complete designation add chain length. For example, to order P625 in 10 ft length, use designation PHC 625X10FT.

**Steel mill series**  
P1000 | P63F4

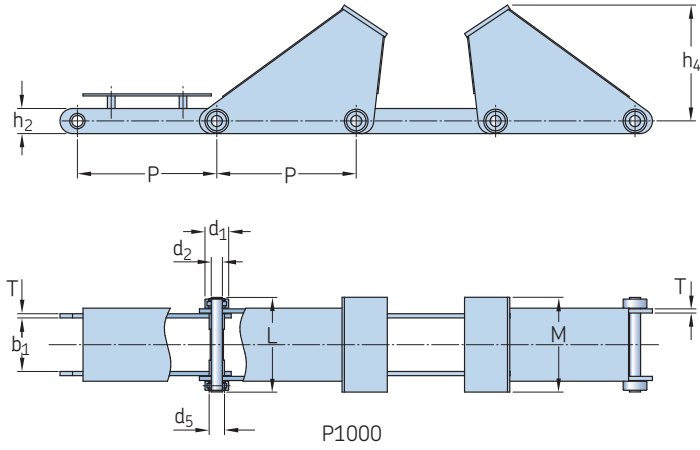

Chain number	Dimensions		Roller diameter		Width between inner plates b <sub>1</sub> Min.	Pin diameter d <sub>2</sub> Max.	Pin length L Max.	Plate height h <sub>2</sub> Max.	Plate thickness T Max.	Attachment dimensions		Ultimate tensile strength Q Min.	Designation
	Pitch		d <sub>1</sub> Max.	d <sub>5</sub> Max.						h <sub>4</sub>	M		
-	mm											kN	-
<b>P1000</b>	1 000		170	110	384	80	678	180	30	832	680	1 800	<b>PHC P1000...</b>

Standard lengths are 10 ft and 5 m. To complete designation add chain length. For example, to order P1000 in 10 ft length, use designation PHC 1000X10FT.

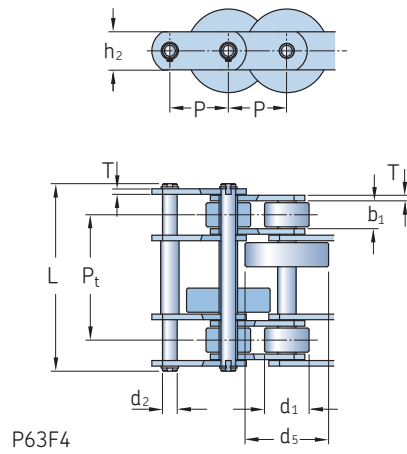

Chain number	Dimensions		Roller diameter		Width between inner plates b <sub>1</sub> Min.	Pin diameter d <sub>2</sub> Max.	Pin length L Max.	Plate height h <sub>2</sub> Max.	Plate thickness T Max.	Transverse pitch P <sub>t</sub>	Ultimate tensile strength Q Min.	Mass per meter q	Designation	
	Pitch		d <sub>1</sub> Max.	d <sub>5</sub> Max.										
-	mm											kN	Kg/m	-
<b>P63F4</b>	63		48	90	30	15,88	202	41	6	135	200	36,57	<b>PHC P63F4...</b>	

Standard lengths are 10 ft and 5 m. To complete designation add chain length. For example, to order P63F4 in 10 ft length, use designation PHC P63F4X10FT.

Steel mill series  
LF155 | P75F9

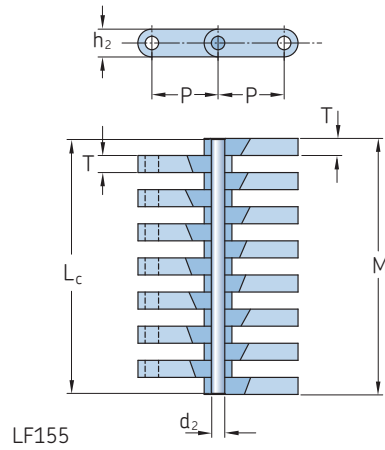

Chain number	Dimensions			Pin diameter $d_2$ Max.	Pin length $L_c$ Max.	Plate thickness $T$ Max.	Plate height $h_2$ Max.	Plate dimension $M$ Max.	Ultimate tensile strength $Q$ Min.	Average tensile strength $Q_0$ Min.	Mass per meter $q$	Designation
	Pitch $P$	Plate Lacing										
-	mm	-	mm						kN		Kg/m	-
<b>LF155</b>	155	7 x 8	31,5	595	40	65	605	3 200	3 520	202,2		<b>PHC LF155...</b>

Standard lengths are 10 ft and 5 m. To complete designation add chain length. For example, to order LF155 in 10 ft length, use designation PHC LF155X10FT.

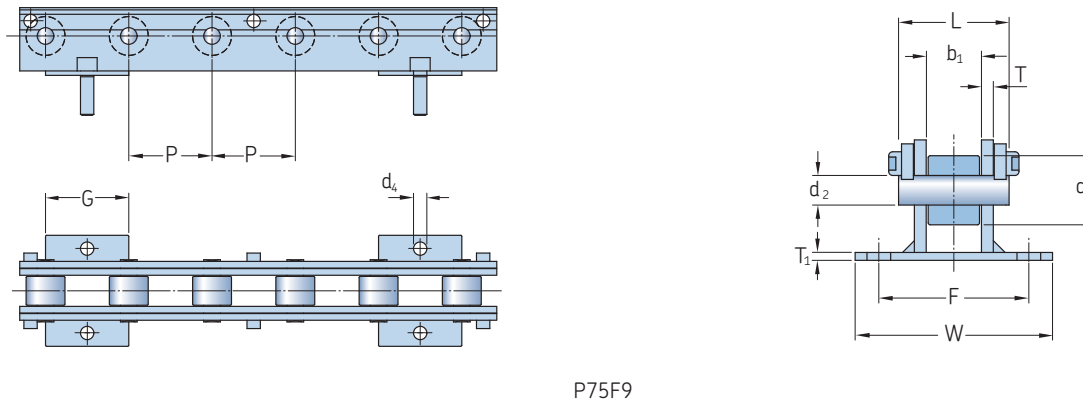

P75F9

Chain number	Dimensions							Attachment dimensions				Mass per meter $q$	Designation	
	Pitch $P$	Roller diameter $d_1$ Max.	Width between inner plates $b_1$ Min.	Pin diameter $d_2$ Max.	Pin length $L$ Max.	Plate thickness $T$ Max.		$T_1$	$W$	$F$	$d_4$			$G$
-	mm												Kg/m	-
<b>P75F9</b>	75	35	28	15	56	6	6	100	76	12	75	22,3		<b>PHC P75F9...</b>

Standard lengths are 10 ft and 5 m. To complete designation add chain length. For example, to order P75F9 in 10 ft length, use designation PHC P75F9X10FT.

Steel mill series  
P50.8F10 | P300F5

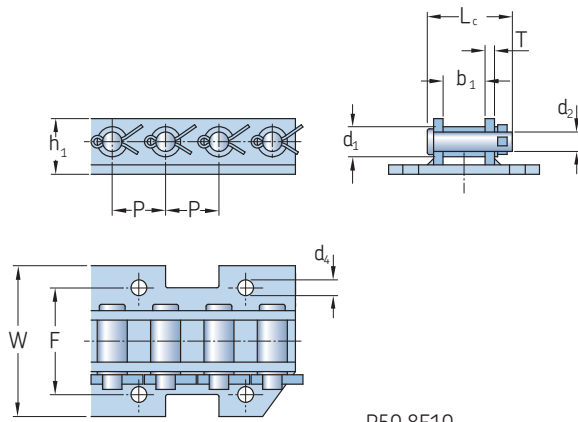

P50.8F10

Chain number	Dimensions							Attachment dimensions				Ultimate tensile strength Q Min.	Mass per meter q	Designation
	Pitch P	Roller diameter $d_1$ Max.	Width between inner plates $b_1$ Min.	Pin diameter $d_2$ Max.	Pin length $L_c$ Max.	Plate thickness T Max.	F	W	$d_4$	$h_1$				
–	mm										kN	Kg/m	–	
<b>P50.8F10</b>	50,8	28,6	40	18,5	80	9	101,6	143,6	15	53	193,0	11,2	<b>PHC P50.8F10...</b>	

Standard lengths are 10 ft and 5 m. To complete designation add chain length. For example, to order P50.8F10 in 10 ft length, use designation PHC P50.8F10X10FT.

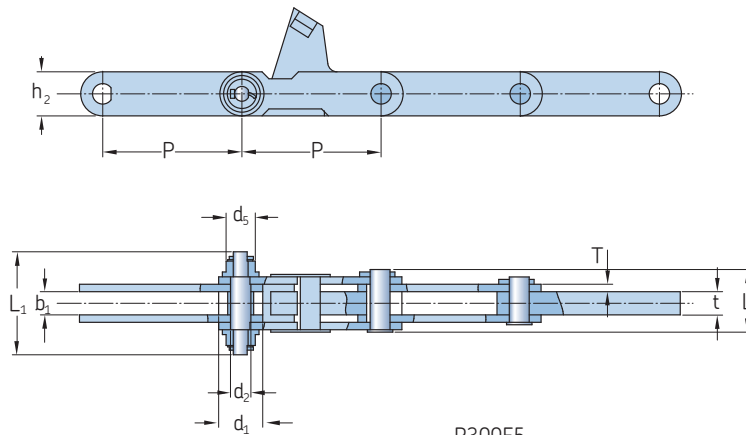

P300F5

Chain number	Dimensions					Attachment dimensions				Ultimate tensile strength Q Min.	Designation
	Pitch P	Roller diameter $d_1$ Max.	Width between inner plates $d_5$ Max.	Width between inner plates $b_1$ Min.	Pin diameter $d_2$ Max.	Pin length L Max.	$L_1$ Max.	Plate thickness t Max.	T Max.		
–	mm									kN	–
<b>P300F5</b>	300	95	65	50	44	135	222	50	16	500	<b>PHC P300F5...</b>

Standard lengths are 10 ft and 5 m. To complete designation add chain length. For example, to order P300F5 in 10 ft length, use designation PHC P300F5X10FT.



Scraper series  
P152F51 | P152F48

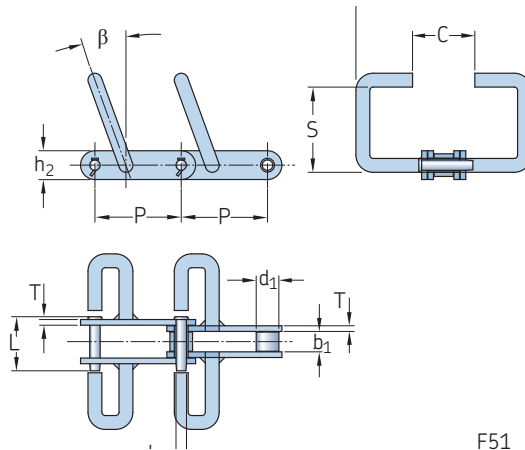

F51

Type	Chain number	Dimensions											Ultimate tensile strength Q Min.	Mass per meter q	Designation
		Pitch P	Roller diameter $d_1$ Max.	Width between inner plates $b_1$	Pin diameter $d_2$	Pin length L	Plate height $h_2$	Plate thickness T	Attachment dimensions S $2x$ C			$\beta$			
-	-	mm											kN	Kg/m	-
F51	P152F51	152,4	40	36	18,5	95,5	50,8	10	175	310	110	20	170	24,9	PHC P152F51...

Standard lengths are 10 ft and 5 m. To complete designation add chain length. For example, to order P152F51 in 10 ft length, use designation PHC P152F51X10FT.

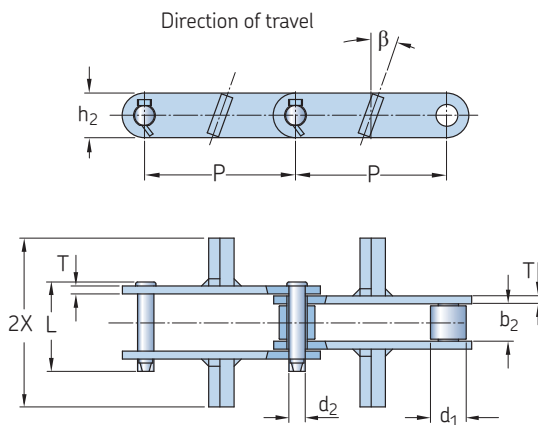

F48

Chain number	Dimensions		Width between inner plates $b_1$	Pin diameter $d_2$	Pin length L	Plate height $h_2$	Plate thickness T	Attachment dimensions			Ultimate tensile strength Q Min.	Designation
	Pitch P	Roller diameter $d_1$						S	$2x$	$\beta$		
-	mm										kN	-
P152F48	152,4	36,0	37,6	16,5	90	47	8	42	170	15	180	PHC P152F48...
R0620MF3	152,4	38,1	37,0	15,9	88	45	8	42	170	15	170	PHC R0620MF3...

Standard lengths are 10 ft and 5 m. To complete designation add chain length. For example, to order P152F48 in 10 ft length, use designation PHC P152F48X10FT.

**Scraper series**  
P152F45 and P152F2

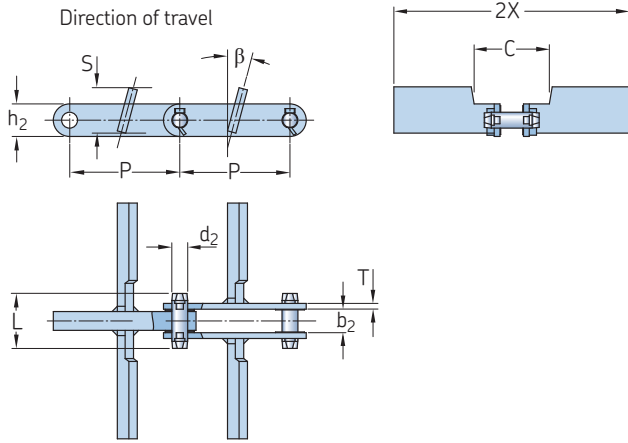

F45

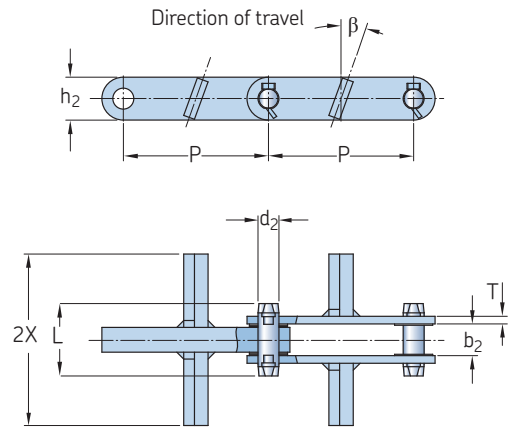

F2

Type	Chain number	Dimensions		Pin diameter $d_2$	Pin length L	Plate height $h_2$	Plate thickness T	Attachment dimensions			Ultimate tensile strength Q Min.	Mass per meter q	Designation	
		Pitch P	Width between outer plates $b_2$					S	$2x$	C				$\beta$
		mm												
F45	P152F45	152,4	32,5	22,0	76,0	45,0	8	64,0	326	104	15	260	20,40	PHC P152F45...
	P152F45A	152,4	32,5	22,0	76,0	45,0	8	83,0	286	106	15	260	20,80	PHC P152F45A...
	P152F45B	152,4	32,5	22,0	76,0	45,0	8	64,0	276	106	15	260	18,00	PHC P152F45B...
	P152F45C	152,4	32,5	22,0	76,0	45,0	8	64,0	227	106	15	260	16,50	PHC P152F45C...
	P152F47	152,4	34,0	22,0	85,0	45,0	12	80,0	400	106	15	400	30,90	PHC P152F47...
	P150F17A	150,0	25,0	18,5	66,3	38,1	10	115,0	180	90	15	150	14,50	PHC P150F17A...
	P200F29	200,0	40,5	35,0	104,0	80,0	13	168,0	420	112	15	530	50,60	PHC P200F29...
	P200F29A	200,0	40,5	35,0	104,0	80,0	13	148,0	430	112	15	530	53,90	PHC P200F29A...
	P200F35	200,0	33,0	26,5	79,0	50,0	10	145,5	430	210	15	400	28,93	PHC P200F35...
F2	P101.6F20	101,6	16,5	17,46	53,7	38,0	6	34	210	-	45	100,0	7,26	PHC P101.6F20...
	P152F2	152,4	33,3	22,00	76,5	45,0	8	38	180	-	20	260,0	12,10	PHC P152F2...
	P152F45D	152,4	32,5	22,00	76,0	45,0	8	42	170	-	15	260,0	13,50	PHC P152F45D...
	P152F45E	152,4	32,5	22,00	76,0	45,0	8	42	280	-	15	260,0	16,20	PHC P152F45E...
	P152F45F	152,4	34,0	22,00	76,0	45,0	8	42	227	-	15	260,0	14,90	PHC P152F45F...
	P150F46	152,4	40,8	25,00	86,0	50,0	9	49	290	-	15	300,0	20,80	PHC P150F46...
	P150F17B	150,0	25,0	18,50	67,3	38,1	10	36	178	-	15	150,0	10,60	PHC P150F17B...

Standard lengths are 10 ft and 5 m. To complete designation add chain length. For example, to order P152F45 in 10 ft length, use designation PHC P152F45X10FT.

Scraper series  
MR, FVR

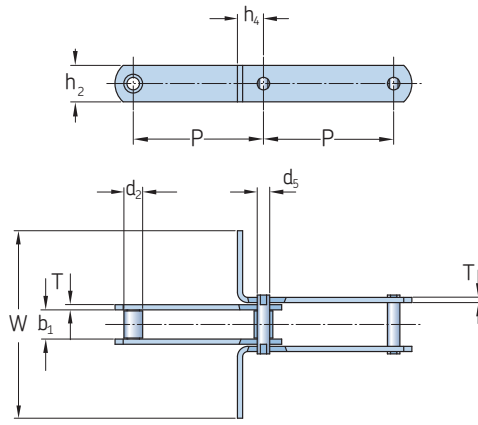

Chain number	Pitch sizes available P		
-	mm		
MR56	100	125	-
MR80	100	125	160
MR112	100	125	160
MR160	100	125	160
MR224	125	160	200
MR315	160	200	250
FVR40	80	100	125
FVR63	100	125	160
FVR90	100	125	160
FVR112	100	125	160
FVR140	125	160	200
FVR180	125	160	200
FVR250	160	200	250

Type	Chain number	Dimensions		Pin diameter d <sub>2</sub> Max.	Plate height h <sub>2</sub> Max.	Plate thickness T Max.	Attachment dimensions		Ultimate tensile strength Q Min.	Designation
		Bush diameter d <sub>5</sub> Max.	Width between inner plates b <sub>1</sub> Min.				h <sub>4</sub>	W		
-	-								kN	-
MR	MR56	15	24	10	30	4	20	-	56	PHC MR56...
	MR80	18	28	12	35	5	25	-	80	PHC MR80...
	MR112	21	32	15	40	6	35	-	112	PHC MR112...
	MR160	25	37	18	50	7	40	-	160	PHC MR160...
	MR224	30	43	21	60	8	44	-	224	PHC MR224...
	MR315	36	48	25	70	10	50	-	315	PHC MR315...
FVR	FVR40	15	18	10	25	3	20	-	42	PHC FVR40...
	FVR63	18	22	12	30	4	25	-	64	PHC FVR63...
	FVR90	20	25	14	35	5	30	-	100	PHC FVR90...
	FVR112	22	30	16	40	6	35	-	120	PHC FVR112...
	FVR140	26	35	18	45	6	38	-	145	PHC FVR140...
	FVR180	30	45	20	50	8	44	-	190	PHC FVR180...
	FVR250	36	55	26	60	8	50	-	275	PHC FVR250...

Standard lengths are 10 ft and 5 m. To complete designation add pitch size and chain length. For example, to order MR56 with 100 mm pitch in 10 ft length, use designation PHC MR56-100X10FT.

Scraper series  
M310-P-125

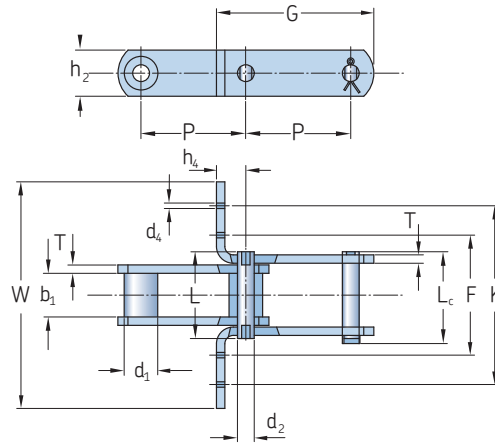

Chain number	Dimensions		Width between inner plates b <sub>1</sub> Min.	Pin diameter d <sub>2</sub> Max.	Pin length		Plate height h <sub>2</sub>	Plate thickness T	Attachment dimensions				Ultimate tensile strength Q Min.	Average tensile strength Q <sub>0</sub>	Mass per meter q	Designation		
	Pitch P	Bush diameter d <sub>1</sub> Max.			L Max.	L <sub>c</sub> Max.			G	F	W	K					h <sub>4</sub>	d <sub>4</sub>
-											mm	kN	Kg/m	-				
M80-P100F1	100,0	18,0	28,0	12,0	55	59	35	5,0	145,5	-	180	-	25	-	80,0	88	5,2	PHC M80-P100F1...
M180-P-100	100,0	26,0	28,9	18,0	63	-	50	6,0	163,0	-	185	-	35	-	180,0	198	10,3	PHC M180-P-100...
M310-P-125	125,0	40,0*	52,0	20,0	103	109	55	10,0	195,0	-	270	-	35	-	303,8	334	19,9	PHC M310-P-125...
M310F1-P-125	125,0	40,0*	52,0	20,0	103	109	55	10,0	195,0	-	560	-	35	-	303,8	334	24,9	PHC M310F1-P-125...
M310F1-P-150	150,0	40,0*	52,0	20,0	103	109	50	10,0	220,0	-	350	-	40	-	303,8	334	19,1	PHC M310F1-P-150...
FVR90F1-B-125	125,0	20,0	25,0	14,0	52	56	40	5,0	175,0	90,0	290	270,0	30	9,0	150,0	165	6,2	PHC FVR90F1-B-125...
P100F16	100,0	23,0	28,0	16,0	66	-	36	6,0	143,0	91,8	180	159,8	25	6,5	115,0	127	6,6	PHC P100F16...
P101.6	101,6	44,5	51,0	23,8	137	-	60	14,5	198,6	-	207	-	62	-	600,0	660	35,0	PHC P101.6...
P125F3	125,0	25,0	36,0	18,0	82	-	51	6,0	190,0	139,5	290	259,5	35	8,5	220,0	242	11,2	PHC P125F3...
P125F4	125,0	25,0	36,0	18,0	82	-	51	6,0	190,0	119,5	220	191,5	35	8,5	220,0	242	9,8	PHC P125F4...
P160F12	160,0	50,0*	34,0	20,0	78	-	50	6,0	230,0	-	215	-	40	-	160,0	176	10,3	PHC P160F12...

Standard lengths are 10 ft and 5 m. To complete designation add chain length. For example, to order M80-P100F1 in 10 ft length, use designation PHC M80-P100F1X10FT.

## Crawler asphalt paver series

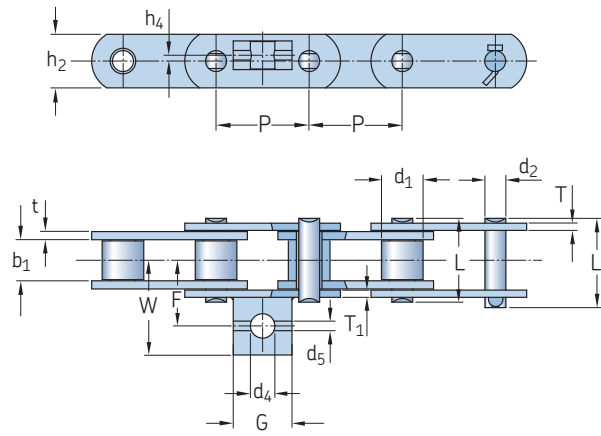

Chain number	Dimensions		Width between inner plates $b_1$ Min.	Pin diameter $d_2$ Max.	Pin length		Plate height $h_2$ Max.	Plate thickness			F	W	G	$h_4$	$d_4$	$d_5$	Ultimate tensile strength Q Min.	Mass per meter q	Designation
	Pitch P	Roller diameter $d_1$			L Max.	$L_c$ Max.		t Max.	T Max.	$T_1$									
-	mm																kN	Kg/m	-
<b>P80F7</b>	80	35,76	35,3	18,0	72,0	76,7	46,00	7,0	6,2	6,2	56,4	81,4	50,5	5,0	21,0	8,2	95	11,91	PHC P80F7...
<b>P80F8</b>	80	27,94	33,8	15,9	68,4	76,0	44,45	6,0	8,0	14,2	63,0	88,0	50,0	2,0	22,0	10,2	190	10,80	PHC P80F8...
<b>P80F17</b>	80	36,00	35,3	18,0	81,0	81,5	45,00	12,7	15,0	66,3	91,3	50,0	7,5	24,0	-	-	195	12,90	PHC P80F17...
<b>P80F19</b>	80	27,94	33,8	15,9	68,4	75,8	45,00	6,0	8,0	20,0	56,5	81,5	50,0	2,8	22,0	8,0	190	11,20	PHC P80F19...
<b>P80F21</b>	80	27,94	34,0	15,9	78,4	-	45,00	6,0	8,0	15,0	57,0	82,0	50,0	7,0	21,5	-	190	10,70	PHC P80F21...

Standard lengths are 10 ft and 5 m. To complete designation add chain length. For example, to order P80F7 in 10 ft length, use designation PHC P80F7X10FT.

Crawler asphalt paver series

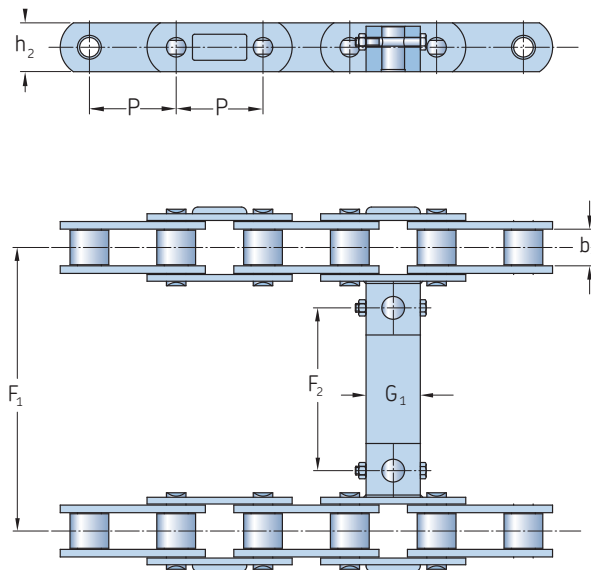

Chain number	Dimensions						Designation
	Pitch	Width between inner plates	Plate height				
	P	b <sub>1</sub>	h <sub>2</sub>	F <sub>1</sub>	F <sub>2</sub>	G <sub>1</sub>	
-	mm						-
P80F8	80	33,8	45	575	449,0	50	PHC P80F8...
P80F17	80	35,3	45	575	442,4	50	PHC P80F17...

Standard lengths are 10 ft and 5 m. To complete designation add chain length. For example, to order P80F8 in 10 ft length, use designation PHC P80F8X10FT.

## Top chain curve movement series

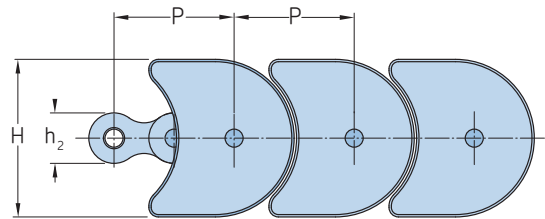
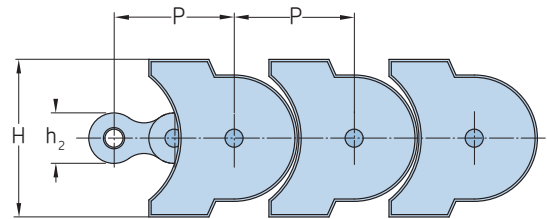
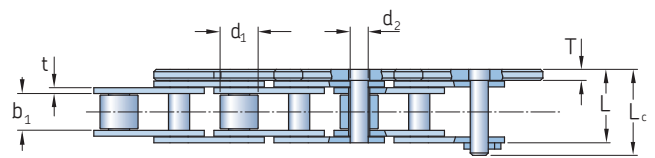
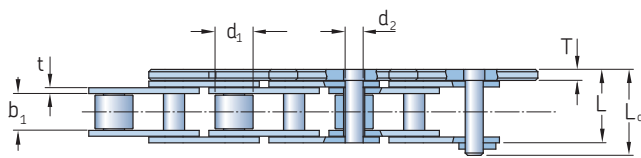

Type A

Type B

Type	Chain number	Dimensions		Pin diameter $d_2$ Max.	Pin length L Max.	Plate height $h_2$ Max.	Plate thickness t	Attachment dimensions		Ultimate tensile strength Q Min.	Average tensile strength $Q_0$	Designation
		Pitch P	Roller diameter $d_1$ Max.					Width between inner plates $b_1$ Min.	H			
-	-	mm								kN		-
A	TOS50	19,05	12,07	5,72	23,3	16,00	1,85	50,0	3,50	29,0	2,35	PHC TOS50...
B	TOS50F1	25,40	12,07	5,72	22,8	21,00	1,85	50,0	3,50	29,0	2,95	PHC TOS50F1...
B	TOS80	38,10	15,88	7,92	32,4	27,30	3,25	82,6	3,25	55,6	4,91	PHC TOS80...

Standard lengths are 10 ft and 5 m. To complete designation add chain length. For example, to order TOS50 in 10 ft length, use designation PHC TOS50X10FT.

## Top chain curve movement series

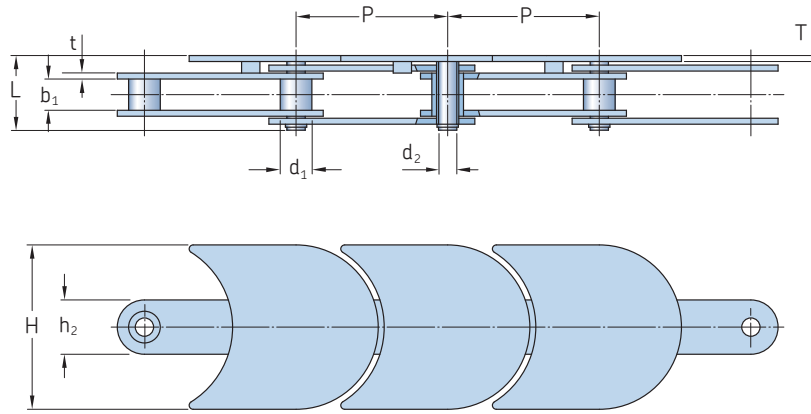

Chain number	Dimensions		Width between inner plates $b_1$ Min.	Pin diameter $d_2$ Max.	Pin length $L$ Max.	Plate height $h_2$ Max.	Plate thickness $t$	Attachment dimensions		Ultimate tensile strength $Q$ Min.	Mass per meter $q$	Designation
	Pitch $P$	Roller diameter $d_1$ Max.						$H$	$T$			
–	mm									kN	Kg/m	–
<b>76HP</b>	76,2	15,92	15,7	9,2	37,5	27,3	3	82,6	3	45	2,76	<b>PHC 76HP...</b>

Standard lengths are 10 ft and 5 m. To complete designation add chain length. For example, to order 76HP in 10 ft length, use designation PHC 76HPX10FT.

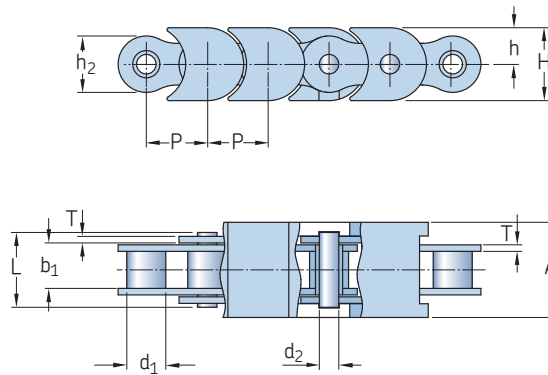

Chain number	Dimensions		Width between inner plates $b_1$ Min.	Pin diameter $d_2$ Max.	Pin length $L$ Max.	Plate height $h_2$ Max.	Plate thickness $T$	Attachment dimensions			Ultimate tensile strength $Q$ Min.	Designation
	Pitch $P$	Roller diameter $d_1$ Max.						$A$	$h$	$H$		
–	mm										kN	–
<b>08B-TP</b>	12,700	8,51	7,75	4,45	16,7	11,8	1,60	19,8	8,0	15,2	18,0	<b>PHC 08B-TP...</b>
<b>10B-TP</b>	15,875	10,16	9,65	5,08	19,5	14,7	1,70	24,8	9,5	17,5	22,4	<b>PHC 10B-TP...</b>
<b>12B-TP</b>	19,050	12,07	11,68	5,72	22,5	16,0	1,85	29,8	11,0	19,8	29,0	<b>PHC 12B-TP...</b>

Standard lengths are 10 ft and 5 m. To complete designation add chain length. For example, to order 08B-TP in 10 ft length, use designation PHC 08B-TPX10FT.



## Double flex series

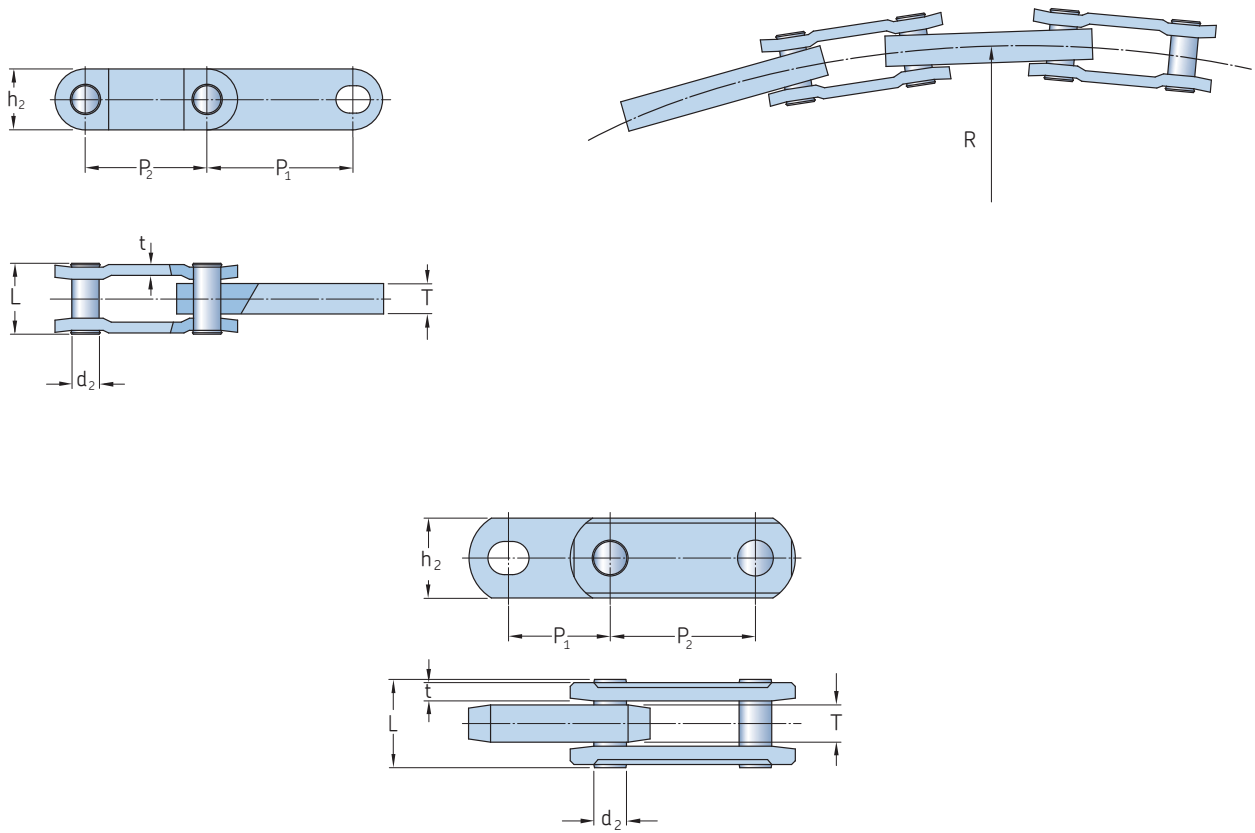

Chain number	Dimensions		Pin diameter $d_2$ Max.	Pin length $L$ Max.	Plate height $h_2$ Max.	Plate thickness		Side bow radius $R$ Min.	Ultimate tensile strength $Q$ Min.	Average tensile strength $Q_0$ Min.	Mass per meter $q$	Designation
	Pitch $P_1$	Pitch $P_2$				$t$	$T$					
–	mm	–	mm						kN		Kg/m	–
<b>3498</b>	44,45	63,5	16,00	39,8	35,56	7,87	16,26	458	180	220	6,17	<b>PHC 3498...</b>
<b>3500</b>	63,50	76,2	14,27	37,0	31,80	6,30	15,90	508	160	196	5,14	<b>PHC 3500...</b>

Standard lengths are 10 ft and 5 m. To complete designation add chain length. For example, to order 3500 in 10 ft length, use designation PHC 3500X10FT.

## Double flex series

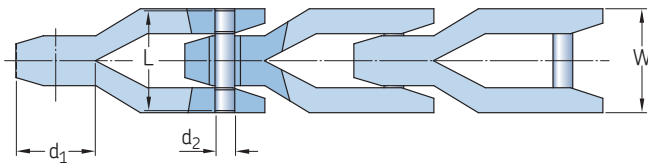
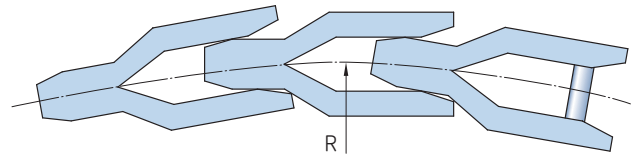
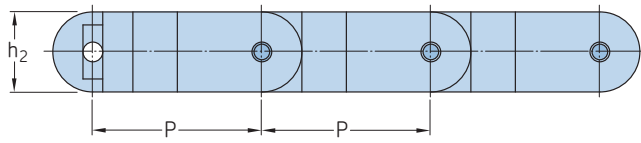

Chain number	Dimensions		Pin diameter d <sub>2</sub> Max.	Pin length L Max.	Plate height h <sub>2</sub> Max.	Plate dimensions		Side bow radius R Min.	Ultimate tensile strength Q Min.	Mass per meter q	Designation
	Pitch P					W Max.	d <sub>1</sub>				
–	mm								kN	Kg/m	–
CC1400	81,3		9,5	48	38,5	50	38	500	30	1,99	PHC CC1400...

Standard lengths are 10 ft and 5 m. To complete designation add chain length. For example, to order CC1400 in 10 ft length, use designation PHC CC1400X10FT.

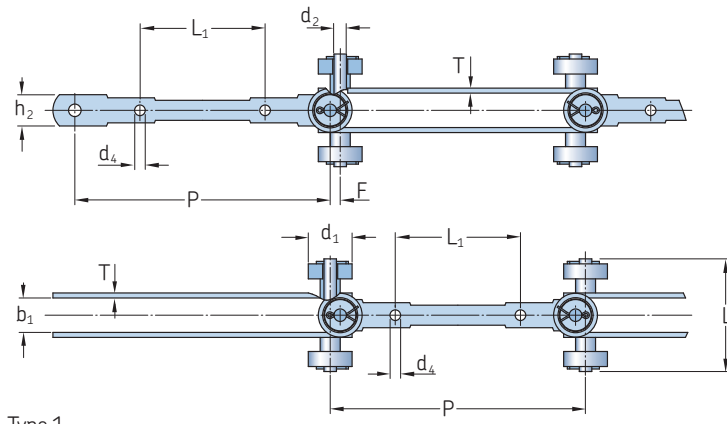

Type 1

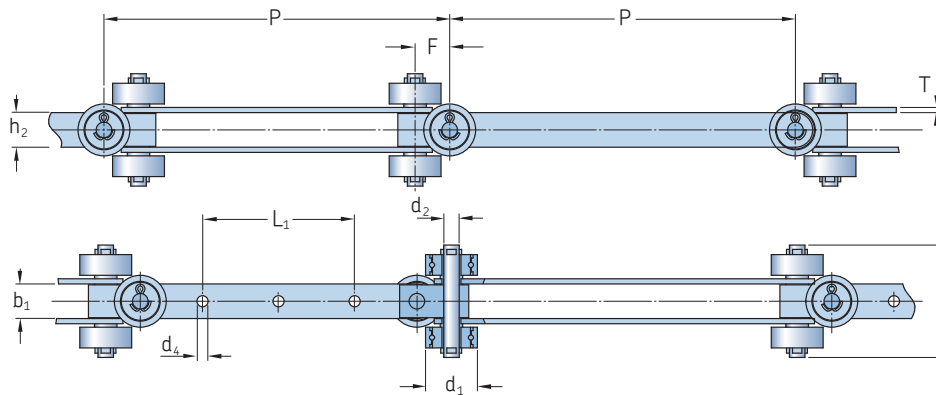

Type 2

Type	Chain number	Dimensions			Pin diameter $d_2$ Max.	Pin length $L$ Max.	Plate height $h_2$ Max.	Plate thickness $T$	Attachment dimensions			Ultimate tensile strength $Q$ Min.	Designation
		Pitch $P$	Roller diameter $d_1$ Max.	Width between inner plates $b_1$ Min.					$L_1$	$d_4$	$F$		
-	-	mm										kN	-
Type 1	P210	204	35	27,5	10	90	25	4	100	8,5	8	50	PHC P210...
Type 1	SJ406S-50	203	35	27,5	10	90	25	4	100	8,5	11	50	PHC SJ406S-50...
Type 2	SJ400-40	200,0	30	20	9	65,0	20	3	88,0	6,44	20,0	15	PHC SJ400-40...
Type 2	SJ400-60	200,0	35	21	10	64,5	20	4	88,0	6,50	20,0	60	PHC SJ400-60...
Type 2	SJ400-100	200,0	40	26	14	75,0	30	4	88,0	10,00	25,0	100	PHC SJ400-100...
Type 2	SJ405S-60	203,2	47	30	14	95,0	30	4	76,2	8,40	16,5	50	PHC SJ405S-60...

Standard lengths are 10 ft and 5 m. To complete designation add chain length. For example, to order P210 in 10 ft length, use designation PHC P210X10FT.

## Universal movement series

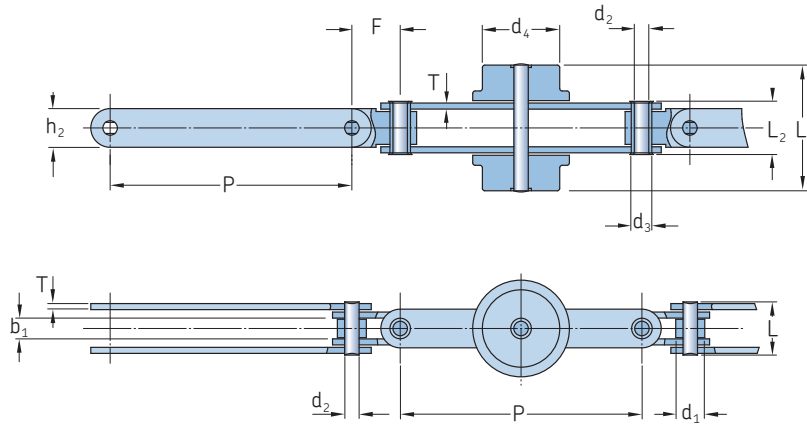

Chain number	Dimensions		Roller diameter		Width between inner plates		Pin diameter			Pin length			Plate		Attachment dimensions F	Ultimate tensile strength Q Min.	Designation
	Pitch P		d1 Max.	d4 Max.	b1 Min.	d2 Max.	d3 Max.	L Max.	L1 Max.	L2 Max.	height h2 Max.	thickness T Max.					
-	mm														kN	-	
<b>P100F11</b>	100		12	32	8,6	6	8,5	22	53	22	16	2,5	20	20	<b>PHC P100F11...</b>		

Standard lengths are 10 ft and 5 m. To complete designation add chain length. For example, to order P100F11 in 10 ft length, use designation PHC P100F11X10FT.

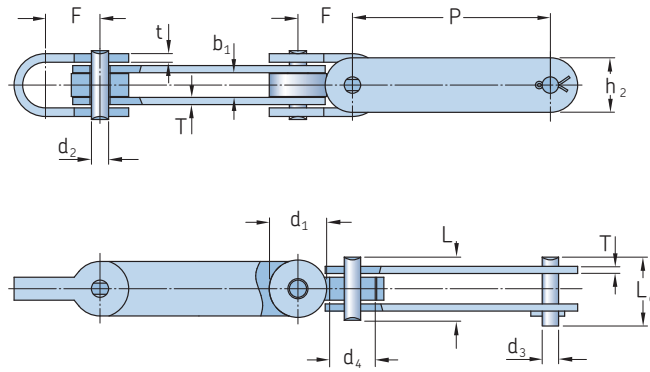

Chain number	Dimensions		Roller diameter		Width between inner plates		Pin diameter			Pin length			Plate		Attachment dimensions F	Ultimate tensile strength Q Min.	Designation
	Pitch P		d1 Max.	d4 Max.	b1 Min.	d2 Max.	d3 Max.	L Max.	Lc Max.	height h2 Max.	thickness T Max.						
-	mm														kN	-	
<b>P69F2</b>	69		20	15,9	8,6	6	5,7	22	24	19	2,5	19	3	20	<b>PHC P69F2...</b>		

Standard lengths are 10 ft and 5 m. To complete designation add chain length. For example, to order P100F11 in 10 ft length, use designation PHC P100F11X10FT.

## Escalator step series

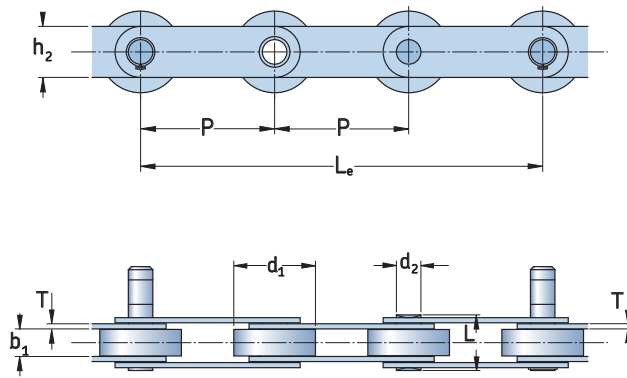

Chain number	Dimensions								Ultimate tensile strength Q Min.	Average tensile strength Q <sub>0</sub>	Mass per step q	Designation
	Pitch P	Roller diameter d <sub>1</sub> Max.	Width between inner plates b <sub>1</sub> Min.	Pin diameter d <sub>2</sub> Max.	Pin length L Max.	Plate height h <sub>2</sub>	Plate thickness T Max.	Distance between steps (three pitches) L <sub>e</sub>				
-	mm								kN		Kg/m	-
ST131	131,33	80	27	24,00	54,5	50	5	394	180	198	3,70	PHC ST131...
T131	131,33	80	27	14,63	55,0	40	5	394	180	198	2,48	PHC T131...
JJT131	131,33	80	27	14,63	54,5	35	5	394	123	150	2,31	PHC JJT131...
ST133	133,33	70	27	14,63	55,0	40	5	400	180	198	2,45	PHC ST133...
ST133F1	133,33	80	27	24,00	54,5	50	5	400	180	198	3,53	PHC ST133F1...

Standard lengths are 10 ft and 5 m. To complete designation add chain length. For example, to order ST131 in 10 ft length, use designation PHC ST131X10FT.

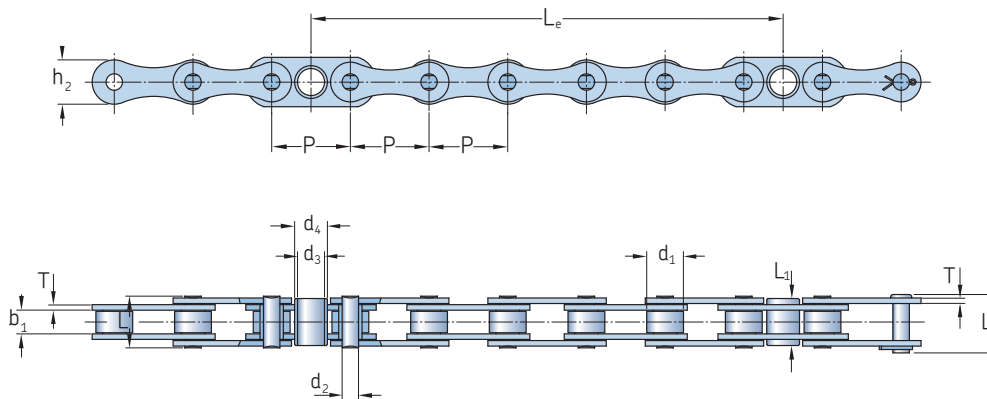

Chain number	Dimensions											Ultimate tensile strength Q Min.	Average tensile strength Q <sub>0</sub>	Mass per meter q	Designation	
	Pitch P	Roller diameter d <sub>1</sub> Max.	Bush diameter d <sub>3</sub>	Bush diameter d <sub>4</sub>	Bush length L <sub>1</sub> Max.	Width between inner plates b <sub>1</sub> Min.	Pin diameter d <sub>2</sub> Max.	Pin length L Max.	Pin length L <sub>1</sub> Max.	Plate height h <sub>2</sub> Max.	Plate thickness T					Distance between steps L <sub>e</sub>
-	mm												kN		Kg/m	-
C-13T	68,40	32,0	23,5	28,5	40,85	20,6	14,29	44,9	50,75	38,5	4,80	410,4	127	140,0	2,30	PHC C-13T...
P67-FD	67,73	28,5	23,0	27,0	36,85	27,0	14,29	52,3	57,00	38,0	4,80	406,4	130	140,0	2,19	PHC P67-FD...

Standard lengths are 10 ft and 5 m. To complete designation add chain length. For example, to order C-13T in 10 ft length, use designation PHC C-13TX10FT.

# Escalator step series

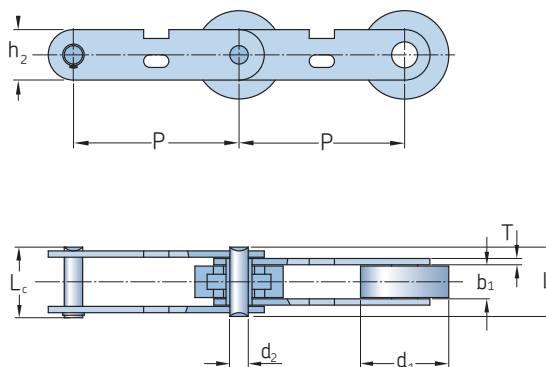

Chain number	Dimensions		Width between inner plates $b_1$ Min.	Pin diameter $d_2$ Max.	Pin length		Plate height $h_2$ Max.	Plate thickness $T$ Max.	Ultimate tensile strength $Q$ Min.	Average tensile strength $Q_0$	Mass per step $q$	Designation
	Pitch $P$	Roller diameter $d_1$ Max.			$L$ Max.	$L_c$ Max.						
-	mm								kN		Kg/m	-
<b>PT131</b>	131,33	70	27	14,63	55	56	40	5	180	198	5,97	<b>PHC PT131...</b>
<b>PT133</b>	133,33	70	27	14,63	55	56	40	5	180	198	5,75	<b>PHC PT133...</b>

Standard lengths are 10 ft and 5 m. To complete designation add chain length. For example, to order PT131 in 10 ft length, use designation PHC PT131X10FT.v

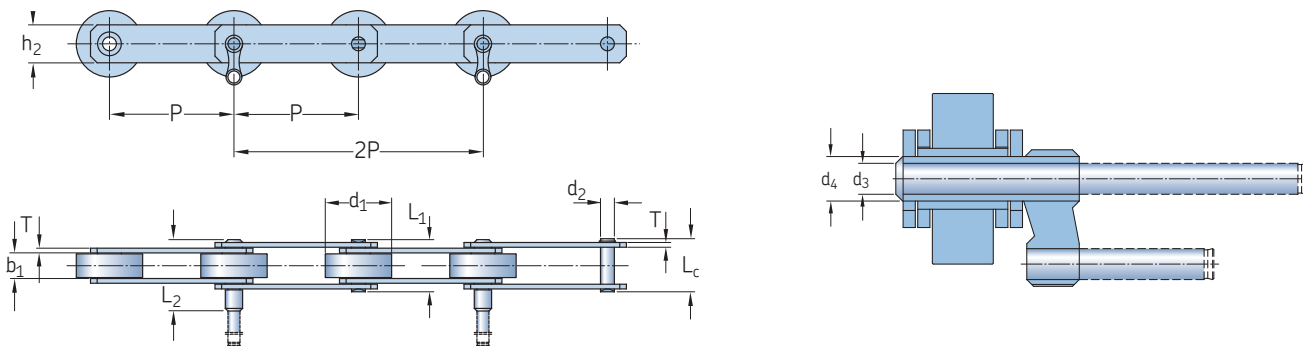

Chain number	Dimensions		Width between inner plates $b_1$ Min.	Pin diameter $d_2$ Max.	(Hollow) Pin diameter		Pin length			Plate height $h_2$ Max.	Plate thickness $T$ Max.	Ultimate tensile strength $Q$ Min.	Average tensile strength $Q_0$	Mass per step $q$	Designation
	Pitch $P$	Roller diameter $d_1$ Max.			$d_3$ Min.	$d_4$ Max.	$L_1$ Max.	$L_2$ Max.	$L_c$ Max.						
-	mm											kN		Kg/m	-
<b>PT131HP</b>	131,33	70	27	14,63	12,7	18,26	55	75,3	56	40	5	150	165	7,53	<b>PHC PT131HP...</b>

Standard lengths are 10 ft and 5 m. To complete designation add chain length. For example, to order PT131HP in 10 ft length, use designation PHC PT131HPX10FT.

## Escalator step series

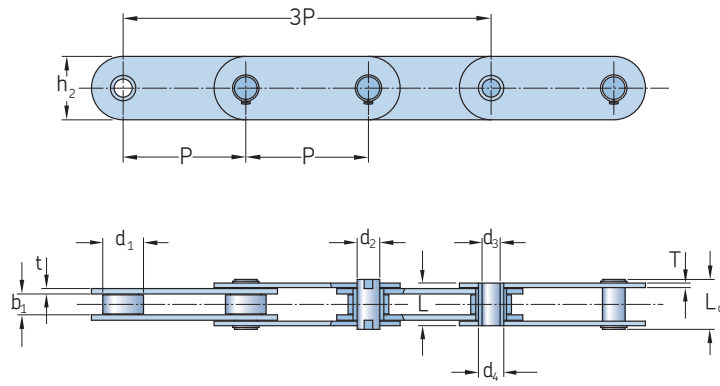

Chain number	Dimensions		Width between inner plates $b_1$ Min.	Pin diameter $d_2$ Max.		(Hollow) Pin diameter $d_3$ Min. $d_4$ Max.		Pin length L Max. $L_c$ Max.		Plate height $h_2$ Max.	Plate thickness t Max. T Max.		Ultimate tensile strength Q Min.	Average tensile strength $Q_0$	Weight per step q	Designation
	P	Roller diameter $d_1$ Max.		$d_1$ Max.	$d_2$ Max.	$d_3$ Min. $d_4$ Max.	L Max. $L_c$ Max.	$h_2$ Max.	t Max. T Max.	kN		Kg/m	-			
-	mm															
PT135HP	135,46	45,0	23	25	20	28	47,1	55,1	70	6	5	250	275	11,26	PHC PT135HP...	

Standard lengths are 10 ft and 5 m. To complete designation add chain length. For example, to order PT135HP in 10 ft length, use designation PHC PT135HPX10FT.

Rice harvester series

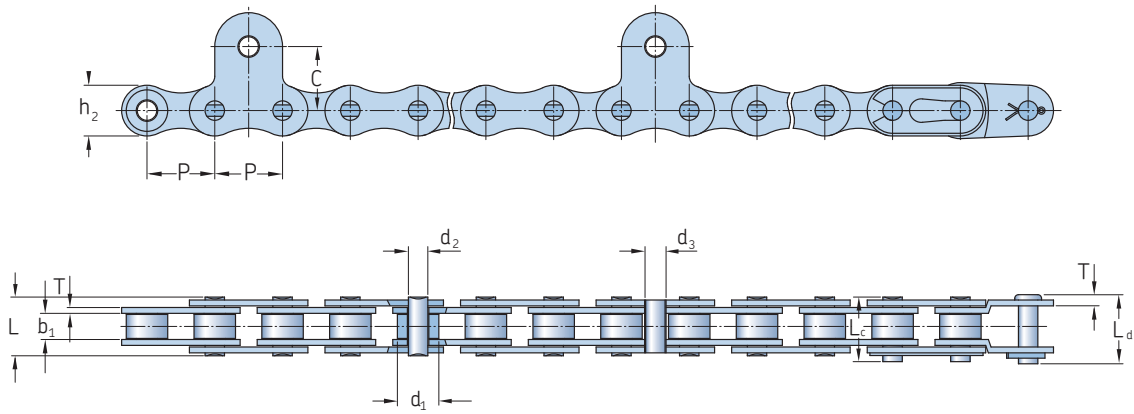

Chain number	Dimensions											Ultimate tensile strength Q Min.	Average tensile strength Q <sub>0</sub>	Designation
	Pitch P	Roller diameter d <sub>1</sub> Max.	Width between inner plates b <sub>1</sub> Min.	Pin diameter d <sub>2</sub> Max.	Pin length			Plate height h <sub>2</sub> Max.	Plate thickness T Max.	Plate dimensions				
-	mm				L Max.	L <sub>c</sub> Max.	L <sub>d</sub> Max.			d <sub>3</sub> nom	C	kN		-
415F1	12,7	7,77	4,90	3,64	11,0	12,1	12,95	9,5	1,1	4,02	12	6,86	8,1	PHC 415F1...
415F2	12,7	7,77	4,90	3,64	11,0	12,1	12,95	9,5	1,1	4,02	12	6,86	8,1	PHC 415F2...
415F3	12,7	7,77	4,90	3,64	11,0	12,1	12,95	9,5	1,1	4,02	12	6,86	8,1	PHC 415F3...
415F4	12,7	7,77	4,68	3,62	11,8	-	-	9,6	1,3	4,00	12	10,30	12,1	PHC 415F4...
415F5	12,7	7,77	4,68	3,63	11,8	13,0	14,00	9,6	1,3	4,00	12	10,30	12,1	PHC 415F5...
415S	12,7	7,77	4,80	3,96	12,8	14,3	15,70	12,0	1,5	4,02	12	15,69	16,3	PHC 415S...
415S-A	12,7	7,77	4,90	3,96	12,8	14,3	15,70	12,0	1,5	4,02	12	13,80	16,3	PHC 415S-A...
415SF1	12,7	7,77	4,80	3,96	13,0	14,5	-	10,4	1,5	4,50	12	13,93	16,3	PHC 415SF1...
415SF2	12,7	7,77	4,80	3,96	13,0	14,5	-	10,4	1,5	4,50	12	13,93	16,3	PHC 415SF2...
415SF3	12,7	7,77	4,80	3,96	12,8	14,3	15,70	12,0	1,5	4,02	12	15,69	16,3	PHC 415SF3...
415SF4	12,7	7,77	4,80	3,96	13,0	14,5	15,70	12,0	1,5	4,00	12	13,80	16,3	PHC 415SF4...
420JF1	12,7	7,77	6,25	3,96	14,7	16,1	18,50	12,0	1,5	4,00	12	16,00	18,8	PHC 420JF1...
415SF6	12,7	7,77	4,80	3,96	13,0	14,5	15,70	10,4	1,5	4,00	12	13,93	16,3	PHC 415SF6...

Standard lengths are 10 ft and 5 m. To complete designation add chain length. For example, to order 415F1 in 10 ft length, use designation PHC 415F1X10FT.

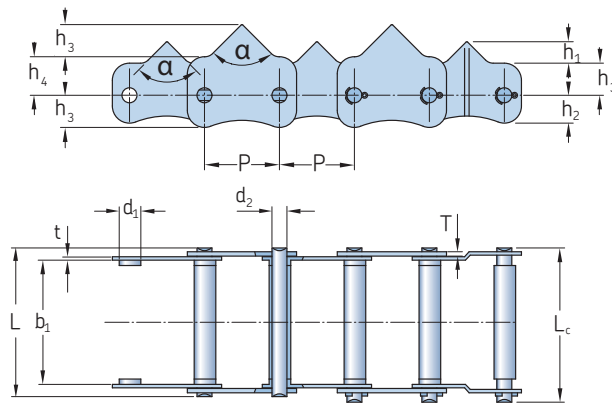

Chain number	Dimensions											Ultimate tensile strength Q Min.	Average tensile strength Q <sub>0</sub>	Designation		
	Pitch P	Roller diameter d <sub>1</sub> Max.	Width between inner plates b <sub>1</sub> Min.	Pin diameter d <sub>2</sub> Max.	Pin length			Tooth angle α	Plate dimensions						Plate thickness t Max.	T Max.
-	mm				L Max.	L <sub>c</sub> Max.		°	mm						kN	-
3558T-48001	35	10,1	58	7	69,4	72,0	90	10	13	15	18	1,6	2,03	19,6	23	PHC 3558T-48001...
3558T-48001F1	35	12,6	58	10	69,4	71,2	90	10	13	15	18	1,6	2,03	19,6	23	PHC 3558T-48001F1...
3558T-48002	35	12,8	58	7	69,4	72,0	90	10	13	15	18	1,6	2,03	19,6	23	PHC 3558T-48002...

Standard lengths are 10 ft and 5 m. To complete designation add chain length. For example, to order 3558T-48001 in 10 ft length, use designation PHC 3558T-48001X10FT.



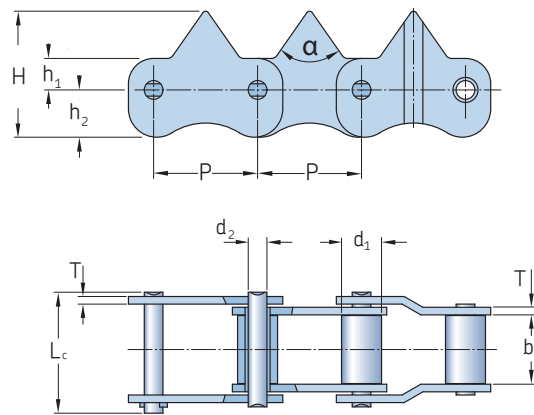

Chain number	Dimensions		Width between inner plates $b_1$ Min.	Pin diameter $d_2$ Max.	Pin length		Tooth angle $\alpha$	Plate dimensions			Plate thickness T	Ultimate tensile strength Q	Average tensile strength $Q_0$	Designation
	Pitch P	Roller diameter $d_1$ Max.			L Max.	$L_c$ Max.		$h_1$	$h_2$	H				
-	mm						°	mm				kN	-	
3322-63201	33	12,7	22	5,94	36,4	38,4	70	10	15	40	2,42	19,6	22,5	PHC 3322-63201...
3325-23160	33	12,8	25	7,00	35,9	38,7	60	10	13	43	1,60	21,6	24,5	PHC 3325-23160...
3330-28361	33	12,8	30	7,00	40,9	43,7	60	10	13	43	1,60	21,6	24,5	PHC 3330-28361...
3330-27150	33	12,8	30	7,00	40,9	43,7	70	10	13	38	1,60	21,6	24,5	PHC 3330-27150...

Standard lengths are 10 ft and 5 m. To complete designation add chain length. For example, to order 3322-63201 in 10 ft length, use designation PHC 3322-63201X10FT.

# Rice harvester series

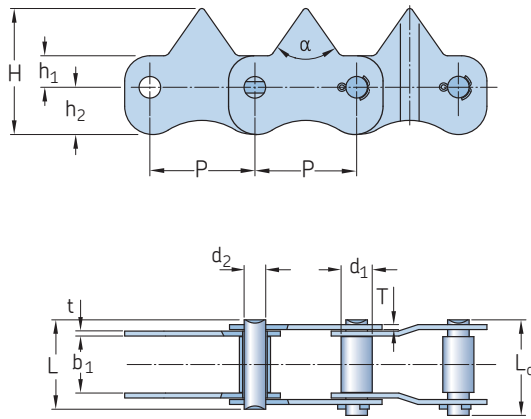

Type 1

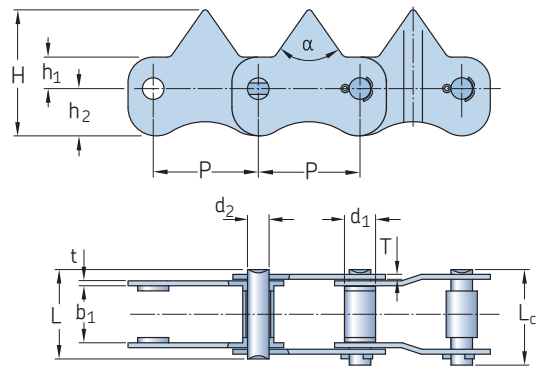

Type 2

Type	Chain number	Dimensions			Pin diameter d <sub>2</sub> Max.	Pin length		Tooth angle α	Plate dimensions			Plate thickness		Ultimate tensile strength Q	Average tensile strength Q <sub>0</sub>	Designation
		Pitch P	Roller diameter d <sub>1</sub> Max.	Width between inner plates b <sub>1</sub> Min.		L	L <sub>c</sub>		h <sub>1</sub>	h <sub>2</sub>	H	t	T			
		mm						°		mm			kN			
Type 1	3318.5-A0680106	33	10.1	18.5	7.0	29.0	31.0	70	10	13	38	1.60	-	19.60	22.5	PHC 3318.5-A0680106...
Type 1	3325-4LB1.35	33	10.1	25.0	7.0	37.0	39.5	90	10	13	38	2.03	-	19.60	24.5	PHC 3325-4LB1.35...
Type 1	3325-4LB1.45	33	10.1	25.0	7.0	35.6	37.6	70	10	13	38	1.70	-	19.60	22.5	PHC 3325-4LB1.45...
Type 1	3325-3572	33	10.1	25.0	7.0	36.8	39.0	70	10	13	38	2.00	1.6	19.60	23.0	PHC 3325-3572...
Type 1	3325-1E6410	33	10.1	25.0	7.0	36.8	39.0	90	10	13	38	2.00	1.6	19.60	23.0	PHC 3325-1E6410...
Type 1	3325-3555	33	10.1	25.0	7.0	36.8	39.0	70	10	13	38	2.00	1.6	19.60	22.5	PHC 3325-3555...
Type 1	3330-4LB1.45	33	10.1	30.0	7.0	40.3	42.7	60	10	13	43	1.70	-	19.60	22.5	PHC 3330-4LB1.45...
Type 1	3330-4LB1.45-01	33	10.1	30.0	7.0	40.3	42.7	70	10	13	38	1.70	-	19.60	22.5	PHC 3330-4LB1.45-01...
Type 1	3340-3572	33	10.1	40.0	7.0	51.8	54.0	70	10	13	38	2.00	1.6	19.60	23.0	PHC 3340-3572...
Type 1	3340-1E8570	33	10.1	40.0	7.0	49.2	52.5	90	18	10	38	1.60	1.2	19.60	22.0	PHC 3340-1E8570...
Type 1	3350-3555	33	10.1	50.0	7.0	60.2	62.5	70	18	10	43	1.60	-	19.60	22.5	PHC 3350-3555...
Type 1	3325-49200	33	12.8	25.0	7.0	35.9	38.7	70	10	13	38	1.60	-	21.60	24.5	PHC 3325-49200...
Type 1	3358-1E8350	33	10.1	58.0	7.0	68.0	72.0	90	18	10	38	1.60	-	19.60	22.5	PHC 3358-1E8350...
Type 1	3358-1E7070	33	10.1	58.0	7.0	68.0	-	90	18	10	38	1.60	-	19.60	22.5	PHC 3358-1E7070...
Type 1	3358-6365	33	10.1	58.0	7.0	68.2	70.5	70	18	10	43	1.60	-	19.60	22.5	PHC 3358-6365...
Type 1	3540-0875	35	10.1	40.0	7.0	50.2	52.5	70	18	10	43	1.60	-	19.60	22.5	PHC 3540-0875...
Type 1	3540-3572	35	10.1	40.0	7.0	50.2	52.5	70	10	10	35	1.60	-	19.60	22.5	PHC 3540-3572...
Type 1	3558-4LB1.35	35	13.2	58.0	9.4	70.0	73.2	90	15	18	47	2.03	-	22.54	27.1	PHC 3558-4LB1.35...
Type 1	3550-5080	35	10.1	50.0	7.0	60.2	62.5	70	18	10	38	1.60	-	19.60	22.5	PHC 3550-5080...
Type 2	3318T-5010	33	10.1	18.0	7.0	28.5	31.4	70	10	13	38	1.60	-	19.60	22.5	PHC 3318T-5010...
Type 2	3322T-52800	33	10.1	22.0	7.0	31.5	34.5	70	10	13	38	1.60	-	17.64	20.2	PHC 3322T-52800...
Type 2	3322T-28241	33	12.1	21.3	7.0	31.8	34.1	60	10	13	43	1.60	-	19.60	22.5	PHC 3322T-28241...
Type 2	3325T-23151	33	10.1	25.0	7.0	35.5	37.7	60	10	13	43	1.60	-	19.60	22.5	PHC 3325T-23151...
Type 2	3325T-49201	33	10.1	25.0	7.0	35.5	37.7	90	10	13	38	1.60	-	19.60	22.5	PHC 3325T-49201...
Type 2	3325T-A0680110	33	10.1	25.0	7.0	35.5	37.7	70	10	13	38	1.60	-	19.60	22.5	PHC 3325T-A0680110...
Type 2	3325T-A0680110F1	33	12.6	25.0	7.0	35.5	37.7	70	10	13	38	1.60	-	19.60	22.5	PHC 3325T-A0680110F1...
Type 2	3325T-3650	33	10.1	25.0	7.0	35.5	37.7	70	10	13	38	1.60	-	19.60	22.5	PHC 3325T-3650...
Type 2	3330T-27151	33	10.1	30.0	7.0	40.5	42.8	70	10	13	38	1.60	-	19.60	22.5	PHC 3330T-27151...
Type 2	3330T-28241	33	10.1	30.0	7.0	40.5	42.8	60	10	13	43	1.60	-	19.60	22.5	PHC 3330T-28241...
Type 2	3330T-28241F1	33	12.6	30.0	7.0	40.5	42.8	60	10	13	43	1.60	-	19.60	22.5	PHC 3330T-28241F1...
Type 2	3330T-28241F2	33	12.1	29.3	7.0	39.8	42.1	60	10	13	43	1.60	-	19.60	22.5	PHC 3330T-28241F2...
Type 2	3330T-3501	33	10.1	30.0	7.0	40.5	42.8	70	10	13	38	1.60	-	19.60	22.5	PHC 3330T-3501...
Type 2	3330T-59750	33	10.1	30.0	7.0	39.5	42.5	60	10	13	43	1.60	-	19.60	22.5	PHC 3330T-59750...
Type 2	3330T-5028	33	10.1	30.0	7.0	40.9	43.7	60	10	13	43	1.60	2.0	19.60	22.5	PHC 3330T-5028...
Type 2	3330T-52200	33	10.1	30.0	7.0	40.9	43.7	60	10	13	43	1.60	2.0	19.60	22.5	PHC 3330T-52200...
Type 2	3335T-27151	33	10.1	35.0	7.0	45.5	47.8	70	10	13	38	1.60	-	19.60	22.5	PHC 3335T-27151...
Type 2	3358T-3330	33	10.1	58.0	7.0	68.0	72.0	90	18	10	38	1.60	-	19.60	22.5	PHC 3358T-3330...
Type 2	3358T-53871	33	10.1	58.0	7.0	68.0	70.8	75	18	10	43	1.60	-	19.60	22.5	PHC 3358T-53871...
Type 2	3358T-6365	33	10.1	58.0	7.0	68.2	72.0	75	18	10	43	1.60	-	19.60	22.5	PHC 3358T-6365...
Type 2	3330T-28242	33	12.8	30.0	7.0	40.5	42.8	60	10	13	43	1.60	-	19.60	22.5	PHC 3330T-28242...
Type 2	3330T-27152	33	12.8	30.0	7.0	40.5	42.8	70	10	13	38	1.60	-	19.60	22.5	PHC 3330T-27152...
Type 2	3350T-744	33	10.1	50.0	7.0	60.2	63.0	90	18	10	38	1.60	-	19.60	22.5	PHC 3350T-744...
Type 2	3325T-699	33	10.1	25.0	7.0	36.2	39.3	90	10	13	38	2.00	1.6	19.60	22.5	PHC 3325T-699...
Type 2	3325T-3817	33	12.1	25.0	7.0	36.2	39.0	90	10	13	38	2.00	1.6	19.60	22.5	PHC 3325T-3817...
Type 2	3330T-3817	33	12.8	30.0	7.0	40.5	42.8	60	10	13	43	1.60	-	19.60	22.5	PHC 3330T-3817...
Type 2	3330T-53981	33	10.1	30.0	7.0	40.5	42.8	70	10	13	38	1.60	-	19.60	22.5	PHC 3330T-53981...
Type 2	3330T-5441	33	10.1	30.0	7.0	40.9	43.7	60	10	13	43	1.60	2.0	19.60	22.5	PHC 3330T-5441...
Type 2	3358T-6365F1	33	12.8	58.0	7.0	68.2	72.0	75	18	10	43	1.60	-	19.60	22.5	PHC 3358T-6365F1...
Type 2	3325T-5060	33	10.1	25.0	7.0	36.8	39.0	70	10	13	38	1.60	2.0	19.60	22.5	PHC 3325T-5060...
Type 2	3350-6379	33	10.1	50.0	7.0	60.2	62.5	75	18	10	43	1.60	-	19.60	22.5	PHC 3350-6379...

Standard lengths are 10 ft and 5 m. To complete designation add chain length. For example, to order 3322-63201 in 10 ft length, use designation PHC 3322-63201X10FT.

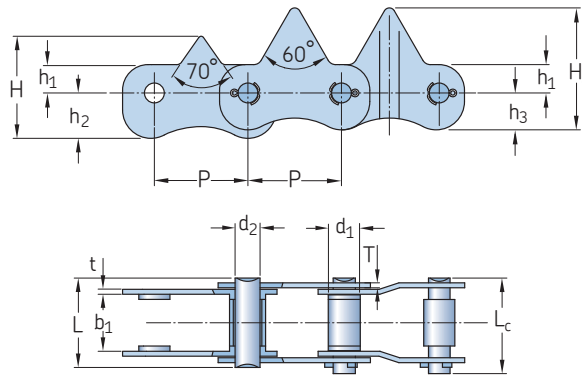

Chain number	Dimensions										Plate thickness		Ultimate tensile strength Q Min.	Average tensile strength Q <sub>0</sub>	Designation			
	Pitch P	Roller diameter d <sub>1</sub> Max.	Width between inner plates b <sub>1</sub> Min.	Pin diameter d <sub>2</sub> Max.	Pin length L Max. L <sub>c</sub> Max.		Tooth angle α ° β °		Plate dimensions h <sub>1</sub> h <sub>2</sub> H <sub>1</sub> h <sub>3</sub> H <sub>2</sub>		t Max.	T Max.						
-	mm												kN		-			
3322T-63203	33	10,1	22	7	33,0	35,7	60	70	10	16	36	13	43	1,6	2,0	19,60	23,0	PHC 3322T-63203...
3330T-66103	33	10,1	30	7	40,9	43,7	60	70	10	16	36	13	43	1,6	2,0	19,60	23,0	PHC 3330T-66103...

Standard lengths are 10 ft and 5 m. To complete designation add chain length. For example, to order 3322T-63203 in 10 ft length, use designation PHC 3322T-63203X10FT.

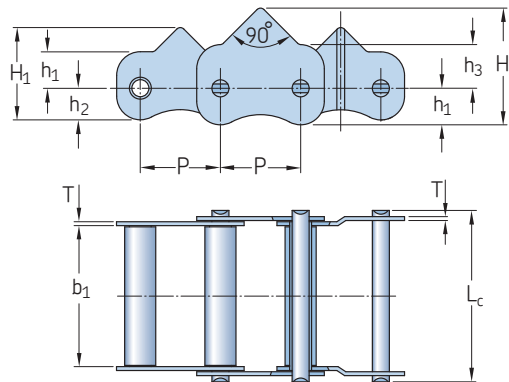

Chain number	Dimensions										Plate thickness		Ultimate tensile strength Q Min.	Average tensile strength Q <sub>0</sub>	Designation		
	Pitch P	Roller diameter d <sub>1</sub> Max.	Width between inner plates b <sub>1</sub> Min.	Pin diameter d <sub>2</sub> Max.	Pin length L Max.		Tooth angle α °		Plate dimensions h <sub>1</sub> h <sub>2</sub> H <sub>1</sub> h <sub>3</sub> H <sub>2</sub>		T Max.						
-	mm												kN		-		
3558-48180	33	12,8	58	7	70,5		90		15	13	38	18	48	1,6	27,44	28,5	PHC 3558-48180...

Standard lengths are 10 ft and 5 m. To complete designation add chain length. For example, to order 3322T-63203 in 10 ft length, use designation PHC 3322T-63203X10FT.

Rice harvester series

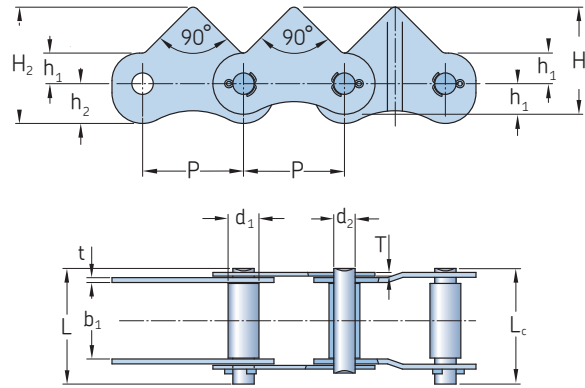

Chain number	Dimensions				Pin length L Max.	Pin length L <sub>c</sub> Max.	Tooth angle		Plate dimensions				Plate thickness		Ultimate tensile strength Q Min.	Average tensile strength Q <sub>0</sub>	Designation
	Pitch P	Roller diameter d <sub>1</sub> Max.	Width between inner plates b <sub>1</sub> Min.	Pin diameter d <sub>2</sub> Max.			α	β	h <sub>1</sub>	H <sub>1</sub>	h <sub>2</sub>	H <sub>2</sub>	t Max.	T Max.			
-	mm						°	°	mm						kN		-
3325-1E8350	33	10,1	25	7,0	34,2	37,8	90		10	35	13	38	1,6	1,20	19,6	22,0	PHC 3325-1E8350...
3325-1E6110	33	10,1	25	7,0	34,2	37,0	70		10	35	13	38	1,6	1,20	19,6	22,0	PHC 3325-1E6110...

Standard lengths are 10 ft and 5 m. To complete designation add chain length. For example, to order 3325-1E8350 in 10 ft length, use designation PHC 3325-1E8350X10FT.

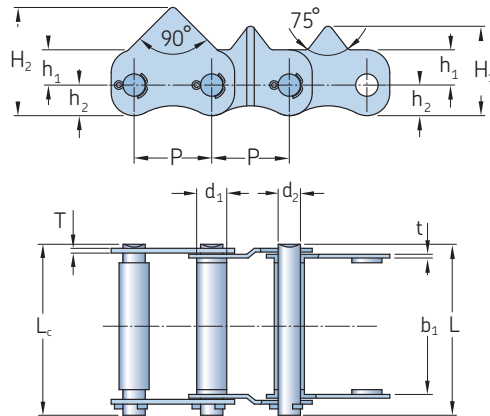

Chain number	Dimensions				Pin length L Max.	Pin length L <sub>c</sub> Max.	Tooth angle		Plate dimensions				Plate thickness		Ultimate tensile strength Q Min.	Average tensile strength Q <sub>0</sub>	Designation
	Pitch P	Roller diameter d <sub>1</sub> Max.	Width between inner plates b <sub>1</sub> Min.	Pin diameter d <sub>2</sub> Max.			α	β	h <sub>1</sub>	H <sub>1</sub>	h <sub>2</sub>	H <sub>2</sub>	t Max.	T Max.			
-	mm						°	°	mm						kN		-
3358T-5K151	33	12,8	58	9,5	69,7	72,7	90	75	15	38	13	46	1,6	2,03	19,6	22,5	PHC 3358T-5K151...
3358T-3653	33	12,8	58	9,5	69,7	72,7	90	90	16	38	12	48	1,6	2,03	19,6	22,5	PHC 3358T-3653...
3358T-762	33	12,8	58	9,5	69,7	72,9	90	75	15	38	13	46	1,6	2,03	19,6	22,5	PHC 3358T-762...

Standard lengths are 10 ft and 5 m. To complete designation add chain length. For example, to order 3325-1E8350 in 10 ft length, use designation PHC 3325-1E8350X10FT.

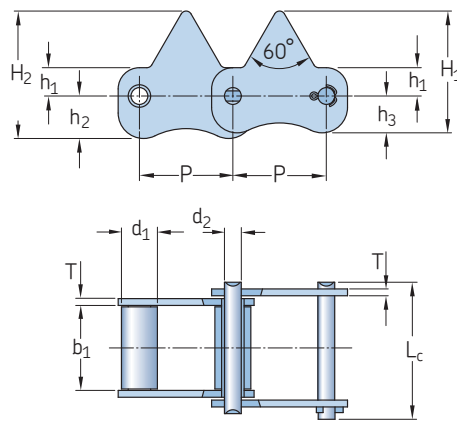

Chain number	Dimensions		Width between inner plates $b_1$ Min.	Pin diameter $d_2$ Max.	Pin length		Tooth angle $\alpha$	Plate dimensions					Plate thickness $T$ Max.	Ultimate tensile strength $Q$ Min.	Average tensile strength $Q_0$	Designation
	Pitch $P$	Roller diameter $d_1$ Max.			L Max.	$L_c$ Max.		$h_1$	$h_2$	$h_3$	$H_1$	$H_2$				
–	mm						°	mm						kN	–	
3330-66401	33	12,7	30	5,9	36,2	46,4	60	10	15	13	43	45	2,4	19,6	22,5	PHC 3330-66401...

Standard lengths are 10 ft and 5 m. To complete designation add chain length. For example, to order 3330-66401 in 10 ft length, use designation PHC 3330-66401X10FT.

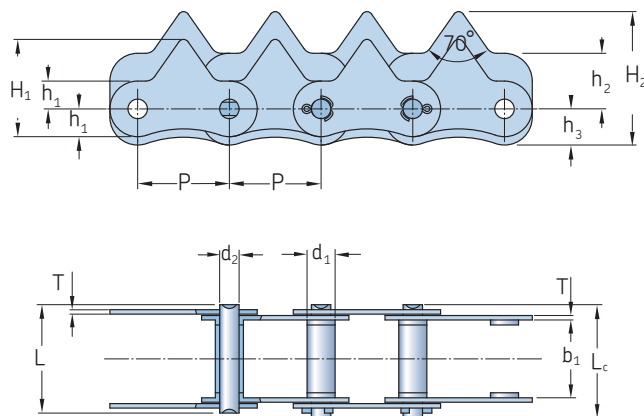

Chain number	Dimensions		Width between inner plates $b_1$ Min.	Pin diameter $d_2$ Max.	Pin length		Tooth angle $\alpha$	Plate dimensions					Plate thickness $T$ Max.	Ultimate tensile strength $Q$ Min.	Average tensile strength $Q_0$	Designation
	Pitch $P$	Roller diameter $d_1$ Max.			L Max.	$L_c$ Max.		$h_1$	$h_2$	$h_3$	$H_1$	$H_2$				
–	mm						°	mm						kN	–	
3325T-1E8350	33	10,1	28	7,0	34,5	39,0	70	10	20	13	35	48	1,6	19,6	22,5	PHC 3325T-1E8350...

Standard lengths are 10 ft and 5 m. To complete designation add chain length. For example, to order 3330-66401 in 10 ft length, use designation PHC 3330-66401X10FT.

## Double plus series

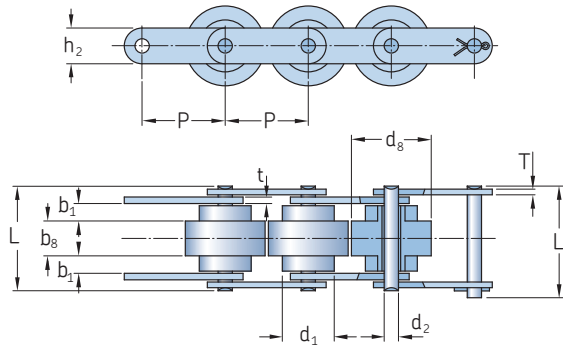

Chain number	Chain number	Dimensions			Width between inner plates		Pin diameter		Pin length		Plate height	Plate thickness		Mass per meter	Designation
		Pitch	Roller dimension		b <sub>1</sub> Min.	b <sub>8</sub> Max.	d <sub>2</sub> Max.	L Max.	L <sub>c</sub> Max.	h <sub>2</sub> Max.	t Max.	T Max.			
mm													Kg/m	-	
BS25-C206B	C2030W	19,05	11,91	18,3	4,00	8,0	3,28	24,0	25,6	8,20	1,50	1,30	0,52	PHC BS25-C206B...	
BS30-C206B	-	19,05	9,00	18,3	4,50	9,1	3,28	26,3	29,6	7,28	1,50	1,30	0,50	PHC BS30-C206B...	
BS25-C208A	C2040W	25,40	15,88	24,6	5,70	10,3	3,96	31,0	32,8	11,70	1,50	1,50	0,79	PHC BS25-C208A...	
BS30-C208A	-	25,40	11,91	24,6	6,10	12,5	3,96	35,6	39,5	9,60	2,00	1,50	0,83	PHC BS30-C208A...	
BS25-C210A	C2050W	31,75	19,05	30,6	7,10	13,0	5,08	39,5	41,2	15,00	2,03	2,03	1,36	PHC BS25-C210A...	
BS30-C210A	-	31,75	14,80	30,6	7,50	15,0	5,08	43,0	47,1	12,20	2,40	2,00	1,27	PHC BS30-C210A...	
BS25-C212A	C2060HW	38,10	22,23	36,6	8,50	15,5	5,94	48,8	51,5	18,00	3,25	3,25	2,19	PHC BS25-C212A...	
BS30-C212A	-	38,10	18,00	37,0	9,75	20,0	5,94	58,1	62,7	15,00	4,00	3,00	2,14	PHC BS30-C212A...	
BS25-C216A	C2080W	50,80	28,58	49,0	11,00	21,5	7,92	66,2	70,0	24,00	5,00	4,00	4,06	PHC BS25-C216A...	
BS30-C216A	-	50,80	22,23	49,0	12,00	25,2	7,92	71,9	77,3	18,60	5,00	4,00	3,55	PHC BS30-C216A...	

Standard lengths are 10 ft and 5 m. To complete designation add chain length. For example, to order BS25-C206B in 10 ft length, use designation PHC BS25-C206BX10FT.

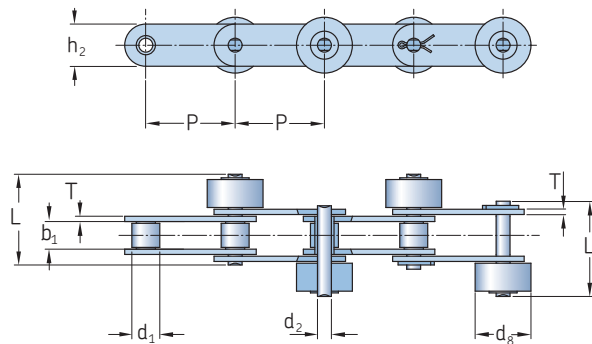

Chain number	Dimensions	Roller dimension		Width between inner plates	Pin diameter	Pin length		Plate height	Plate thickness	Ultimate tensile strength	Average tensile strength	Mass per meter	Designation
		Pitch	d <sub>8</sub> Max.			d <sub>2</sub> Max.	L Max.						
mm										kN	Kg/m	-	
C2040S2-PSR	25,40	7,95	15,88	7,85	3,96	25,8	27,0	12	1,50	13,8	15,18	0,99	PHC C2040S2-PSR...
C2050S	31,75	10,16	19,05	9,40	5,08	31,8	34,0	15	2,03	21,8	23,90	1,52	PHC C2050S...
C2052SF1	31,75	19,05	27,00	9,40	5,08	35,0	37,3	15	2,03	21,8	23,90	3,06	PHC C2052SF1...
C2060HS	38,10	11,91	22,23	12,57	5,94	44,0	46,6	18	3,25	31,1	42,70	1,78	PHC C2060HS...

Standard lengths are 10 ft and 5 m. To complete designation add chain length. For example, to order C2040S2-PSR in 10 ft length, use designation PHC C2040S2-PSRX10FT.

## Double plus series

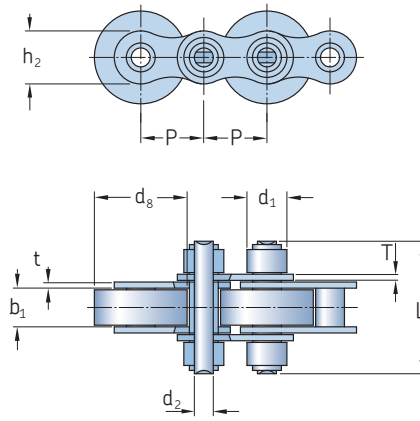

Chain number	Dimensions		Width between inner plates $b_1$ Min.	Pin diameter $d_2$ Max.	Pin length $L$ Max.	Plate height $h_2$ Max.	Plate thickness		Ultimate tensile strength $Q$ Min.	Average tensile strength $Q_a$ Min.	Designation
	Pitch $P$	Roller dimension $d_1$ Max. $d_8$ Max.					$t$ Max.	$T$ Max.			
–	mm								kN	–	–
08BS-27-P16/C16	12,70	8,51 16,0	7,75	4,45	27	11,8	1,6 1,5	18,0	19,8	PHC 08BS-27-P16/C16...	
12BS	19,05	12,07 28,0	11,68	5,72	45	16,0	1,85 1,85	28,9	31,7	PHC 12BS...	
12BS-40-P28/C28	19,05	12,07 28,0	11,68	5,72	40	16,0	1,85 1,85	29,0	31,7	PHC 12BS-40-P28/C28...	
12BS-43-P26/C26	19,05	12,07 26,0	11,68	5,72	43	16,0	1,85 1,85	29,0	31,7	PHC 12BS-43-P26/C26...	
12BS-43-P28/C28	19,05	12,07 28,0	11,68	5,72	43	16,0	1,85 1,85	29,0	31,7	PHC 12BS-43-P28/C28...	
12BS-48-P24/C24	19,05	12,07 24,0	11,68	5,72	48	16,0	1,85 1,85	29,0	31,7	PHC 12BS-48-P24/C24...	
12BS-48-P26/C26	19,05	12,07 26,0	11,68	5,72	48	16,0	1,85 1,85	29,0	31,7	PHC 12BS-48-P26/C26...	
12BS-48-P28/C28	19,05	12,07 28,0	11,68	5,72	48	16,0	1,85 1,85	29,0	31,7	PHC 12BS-48-P28/C28...	
16BS-65-P38/C38	25,40	38,00 15,88	17,02	8,28	65	21,0	4,15 3,1	60,0	72,8	PHC 16BS-65-P38/C38...	

Standard lengths are 10 ft and 5 m. To complete designation add chain length. For example, to order 08BS-27-P16/C16 in 10 ft length, use designation PHC 08BS-27-P16/C16X10FT.

## Crank link drive series

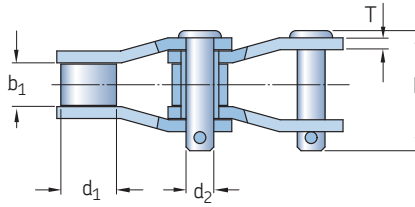
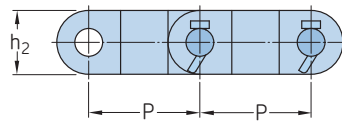

Chain number	Dimensions		Roller diameter	Width between inner plates	Pin diameter	Pin length	Plate height	Plate thickness	Ultimate tensile strength	Average tensile strength	Mass per meter	Designation
	Pitch											
-	mm								kN		Kg/m	-
2010	63,50		31,75	38,10	15,90	89,0	47,8	7,9	250	270,0	13,53	PHC 2010...
2512	77,90		41,28	39,60	19,05	100,0	57,0	9,7	340	367,2	18,40	PHC 2512...
3315	103,45		45,24	49,30	23,85	130,0	63,5	14,2	550	594,0	27,71	PHC 3315...
3618	114,30		57,15	52,30	27,97	138,0	79,2	14,2	760	820,8	41,20	PHC 3618...
4020	127,00		63,50	69,90	31,78	165,7	88,9	15,7	987	1069,2	48,60	PHC 4020...
882	66,27		22,23	28,58	11,10	68,5	28,5	6,4	115	124,8	5,30	PHC 882...
1242	103,20		44,45	49,20	22,23	124,5	57,0	12,8	623	672,8	24,63	PHC 1242...
SS588	66,27		22,23	28,60	11,11	63,7	28,6	6,4	130	144,0	5,46	PHC SS588...
SS40H(P)	78,11		31,75	38,10	15,88	97,0	41,5	9,5	250	280,0	12,60	PHC SS40H(P)...
SS124	103,20		44,45	49,20	22,23	127,2	57,0	12,7	560	590,0	22,57	PHC SS124...
SS1245	103,45		45,20	49,60	23,80	129,4	60,0	14,5	550	605,0	31,19	PHC SS1245...
SS635H	114,3		57,20	52,40	27,94	137,0	76,2	14,5	760	836,0	37,80	PHC SS635H...

Standard lengths are 10 ft and 5 m. To complete designation add chain length. For example, to order 2010 in 10 ft length, use designation PHC 2010X10FT.



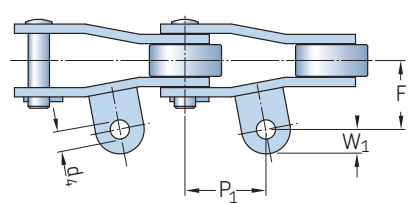
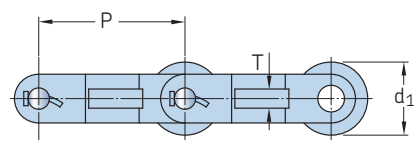
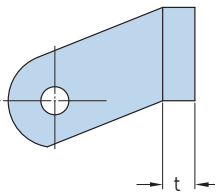
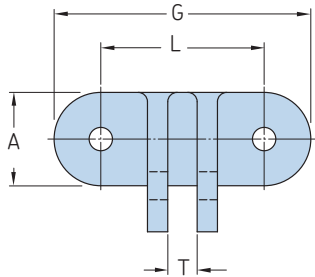
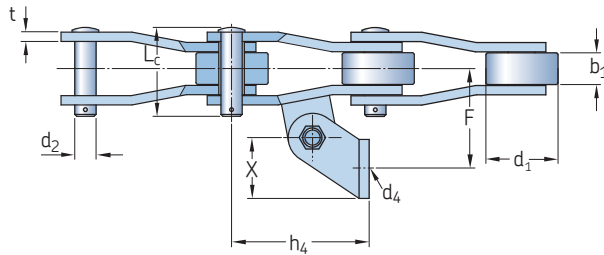
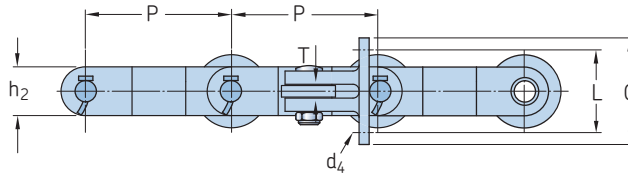

Attachment with flight wings\*

Attachment A-42

Chain number	Dimensions		Roller diameter $d_1$ Max.	Width between inner plates $b_1$ Min.	Pin length $L_c$	Pin diameter $d_2$	Plate depth $h_2$	Plate thickness $T$	Attachment dimensions						Ultimate tensile strength $Q$	Designation
	Pitch	P							G	L	F	X	$d_4$	$h_4$		
	mm	inch	mm						G	L	F	X	$d_4$	$h_4$	kN	
F2184	152,4	6	76,2	34	95,1	22,23	50,8	9,52	127	88,9	100	50,8	12,7	143,0	356	PHC F2184....
A2184	152,4	6	76,2	34	95,1	22,23	50,8	9,52	127	88,9	100	50,8	12,7	143,0	350	PHC A2184....
N2184	152,4	6	76,2	34	95,1	22,23	50,8	9,52	127	88,9	100	50,8	12,7	143,0	320	PHC N2184....

F = Standard materials  
 N = Nickel plated bush and pin  
 A = Stainless steel bush and pin

\* Dimensions for attachment flight wing can be requested from SKF.  
 Standard lengths are 10 ft and 5 m. To complete designation add chain length. For example, to order 2184 in 10 ft length, use designation PHC 2184X10FT.

## 9060 Series

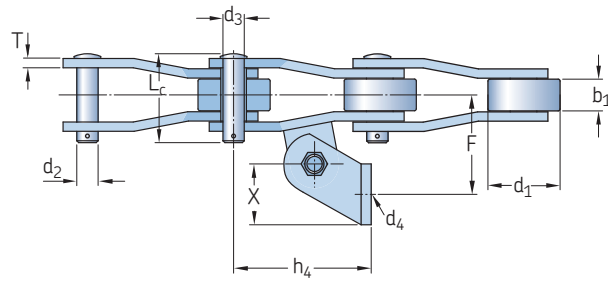
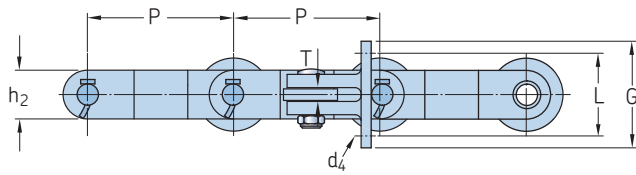

9060A/9061A/9063  
AS-2

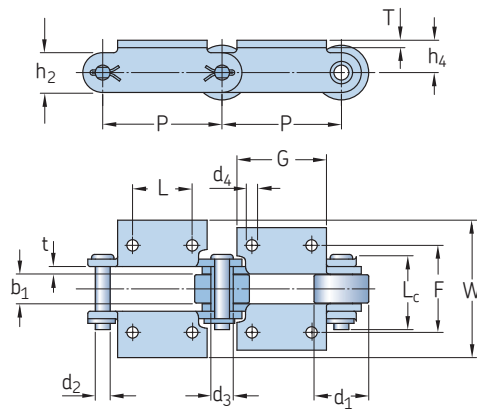

9064/9060B/9061B  
K-2

Chain number	Dimensions		Roller diameter $d_1$ Max.	Width between inner plates $b_1$ Min.	Pin length $L_c$	Bush diameter $d_3$	Pin diameter $d_2$	Plate depth $h_2$	Plate thickness $T$	Attachment dimensions						Ultimate tensile strength $Q$	Designation	
	P	P								G	L	F	W	X	$d_4$			$h_4$
–	mm	inch	mm														kN	–
9060A	152,4	6	69,85	38,1	96,60	28,70	19,05	50,80	9,65	114,3	82,55	88,90	–	50,80	12,7	111,25	270,00	PHC 9060A...
9060B	152,4	6	69,85	38,1	96,60	28,70	19,05	50,80	9,65	114,3	76,20	111,25	171,45	–	12,7	41,40	270,00	PHC 9060B...
9061A	152,4	6	69,85	38,1	107,00	28,70	19,05	57,50	9,65	114,3	82,55	88,90	–	50,80	12,7	111,25	377,80	PHC 9061A...
9061B	152,4	6	69,85	38,1	107,00	28,70	19,05	57,50	9,65	114,3	76,20	111,25	165,10	–	12,7	41,40	377,80	PHC 9061B...
9063	152,4	6	76,20	38,1	103,20	31,75	23,88	60,45	10,41	127,0	88,9	100,00	–	50,80	12,7	143,00	622,20	PHC 9063...
9064	152,4	6	76,20	38,1	112,50	31,75	23,88	60,45	10,41	114,3	76,2	111,30	165,10	–	12,7	44,45	622,20	PHC 9064...

Standard lengths are 10 ft and 5 m. To complete designation add chain length. For example, to order 9060A in 10 ft length, use designation PHC 9060AX10FT.

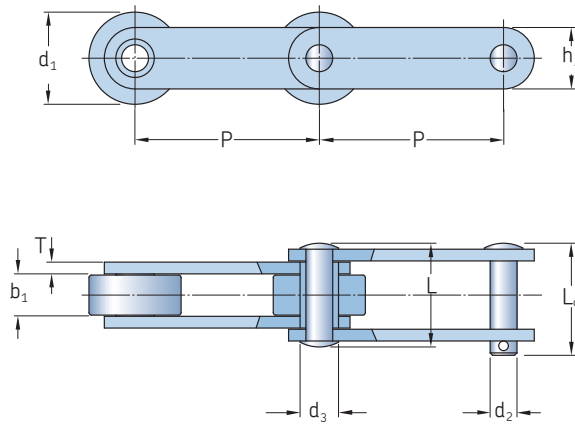

Chain number	Dimensions			Pin diameter d <sub>2</sub>	Pin length L <sub>c</sub>	Bush diameter d <sub>3</sub>	Plate height h <sub>2</sub>	Plate thickness T	Rated working load	Ultimate tensile strength Q <sub>Min.</sub>	Mass per meter	Designation
	Pitch P	Roller diameter d <sub>1</sub>	Width between inner links b <sub>1</sub>									
-	mm								N	kN	Kg	-
RS3013...	76,20	38,10	25,40	11,13	53,60	16,00	28,70	4,80	9,34	58,0	6,00	PHC RS3013...
RS4113 CR...	101,60	44,50	28,70	11,13	56,90	16,00	28,70	4,80	7,21	58,0	6,20	PHC RS4113 CR...
RS4013...	101,60	38,10	25,40	11,13	53,60	16,00	28,70	4,80	9,34	58,0	5,10	PHC RS4013...
RS4113 ...	101,60	44,50	28,70	11,13	56,90	16,00	28,70	4,80	9,56	58,0	6,20	PHC RS4113 ...
RS4216...	101,60	50,80	28,70	11,13	56,90	16,00	28,70	4,80	10,23	67,0	7,30	PHC RS4216...
RS4019...	101,60	38,10	23,10	12,70	57,70	18,30	31,80	6,40	10,90	93,0	6,20	PHC RS4019...
RS2118...	101,60	44,50	32,50	15,88	80,60	23,10	38,10	7,90	18,68	102,0	10,40	PHC RS2118...
RS4328...	101,60	57,20	33,30	15,88	88,70	22,40	38,10	9,70	20,02	125,0	14,40	PHC RS4328...
RS1113CR...	102,60	50,80	32,50	15,88	80,60	23,10	38,10	7,90	14,01	102,0	11,30	PHC RS1113CR...
RS1113...	102,60	50,80	32,50	15,88	80,60	23,10	38,10	7,90	18,68	102,0	11,30	PHC RS1113...
RS60...	102,60	50,80	33,30	17,48	88,90	26,90	38,10	9,70	22,02	102,0	12,60	PHC RS60...
RS6018CR...	152,40	50,80	28,70	11,13	63,00	16,00	31,80	6,40	8,67	80,0	7,40	PHC RS6018CR...
RS6018...	152,40	50,80	28,70	11,13	63,00	16,00	31,80	6,40	11,57	80,0	7,40	PHC RS6018...
RS1116CR...	152,40	50,80	31,80	14,30	72,40	20,60	38,10	6,40	11,52	93,0	7,40	PHC RS1116CR...
RS1114CR...	152,40	50,80	32,50	15,88	80,60	23,10	38,10	7,90	14,01	102,0	9,40	PHC RS1114CR...
RS1736CR...	152,40	57,20	32,50	15,88	80,60	23,10	38,10	7,90	14,01	102,0	10,30	PHC RS1736CR...
RS1116 ...	152,40	50,80	31,80	14,30	70,60	20,60	38,10	6,40	15,35	93,0	7,40	PHC RS1116 ...
RS2190...	152,40	63,50	31,80	14,30	70,60	20,60	38,10	6,40	15,35	93,0	10,40	PHC RS2190...
RS1114...	152,40	50,80	32,50	15,88	80,60	23,10	38,10	7,90	18,68	102,0	9,40	PHC RS1114...
RS951...	152,40	76,20	33,30	15,88	80,50	23,10	38,10	7,90	19,57	165,0	15,90	PHC RS951...
RS6238...	152,40	63,50	35,10	19,05	92,20	28,50	50,80	9,70	24,91	200,0	16,20	PHC RS6238...
RS6438...	152,40	76,20	35,10	19,05	92,20	28,50	50,80	9,70	24,91	200,0	18,70	PHC RS6438...
RS1131...	152,40	76,20	38,10	19,05	98,30	28,50	50,80	9,70	26,24	200,0	18,60	PHC RS1131...
RS996...	152,40	69,90	38,10	19,05	98,30	28,50	50,80	9,70	26,24	280,0	17,60	PHC RS996...
RS1796...	152,40	69,90	38,10	22,17	98,60	31,50	57,20	9,70	30,69	262,0	14,20	PHC RS1796...
960...	152,40	69,90	38,10	21,84	114,30	33,00	57,20	12,70	34,03	285,0	14,80	PHC 960...
RS2047...	152,40	76,20	41,40	23,83	102,20	35,00	63,50	9,70	34,69	436,0	21,20	PHC RS2047...
RS2600...	152,40	88,90	66,30	25,40	127,00	38,10	76,20	9,70	52,93	498,0	27,00	PHC RS2600...
RS2800...	203,20	88,90	66,30	25,40	127,00	38,10	69,90	9,70	52,93	498,0	26,50	PHC RS2800...
RS911...	228,60	76,20	38,10	15,88	88,10	23,10	50,80	7,90	20,46	147,0	12,60	PHC RS911...
SS927...	228,60	88,90	50,80	19,05	107,20	28,70	50,80	9,70	32,03	151,0	17,90	PHC SS927...
RS4851...	228,60	76,20	57,20	22,23	117,30	32,00	63,50	9,70	40,92	290,0	21,60	PHC RS4851...
RS1211...	304,80	76,20	38,10	15,88	88,10	23,10	50,80	7,90	20,46	138,0	10,40	PHC RS1211...
SS4038...	304,80	82,60	41,40	19,05	97,60	26,90	50,80	9,70	27,58	129,0	13,40	PHC SS4038...
SS1227...	304,80	88,90	50,80	19,05	107,20	28,70	50,80	9,70	32,03	151,0	14,90	PHC SS1227...
RS4850...	304,80	76,20	57,20	22,23	117,30	32,00	63,50	9,70	40,92	280,0	18,90	PHC RS4850...

Standard lengths are 10 ft and 5 m. To complete designation add chain length. For example, to order RS4113CR in 10 ft length, use designation PHC RS4113CRX10FT.

# Hoisting series

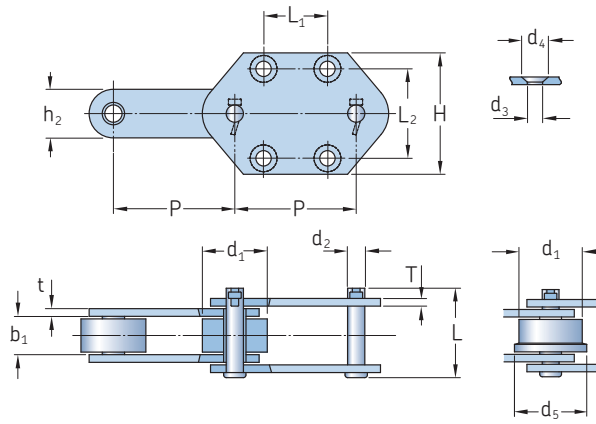

Chain number	Dimensions				Pin diameter d <sub>2</sub> Max.	Pin length L Max.	Plate height h <sub>2</sub> Max.	H	L <sub>1</sub>	L <sub>2</sub>	d <sub>3</sub>	d <sub>4</sub>	Plate thickness		Ultimate tensile strength Q Min.	Average tensile strength Q <sub>0</sub>	Mass per meter q	Designation
	Pitch P	Roller diameter d <sub>1</sub> Max.	d <sub>5</sub>	Width between inner plates b <sub>1</sub> Min.									t Max.	T Max.				
–	mm												kN		Kg/m		–	
<b>P95</b>	95,0	50,8	58	30,0	13,5	70,0	38,0	95	50	70	12,0	21	6,0	–	75	82,5	9,93	PHC P95...
<b>RF10150RF1</b>	150,0	50,0	60	30,0	14,5	69,0	38,1	100	75	70	11,0	20	8,0	6,3	200	220,0	8,64	PHC RF10150RF1...
<b>P152F41</b>	152,4	38,1	–	36,0	15,5	90,0	50,0	110	75	70	14,5	25	8,0	–	150	165,0	11,91	PHC P152F41...
<b>RF17200MF1-G-4</b>	200,0	44,5	–	51,4	19,1	120,0	60,0	125	100	80	18,0	33	10,0	–	245	269,5	17,60	PHC RF17200MF1-G-4...
<b>RF17200MF2-G-4</b>	200,0	44,5	–	51,4	19,1	109,5	50,8	120	100	80	15,0	26	9,5	–	213	243,0	15,10	PHC RF17200MF2-G-4...
<b>P250F6</b>	250,0	63,5	–	67,0	31,8	146,0	90,0	150	140	100	17,7	30	12,0	–	450	495,0	31,70	PHC P250F6...
<b>P300F1</b>	300,0	70,0	–	75,0	35,0	174,0	100	180	170	120	22,0	39	16,0	–	1065	1118,0	47,47	PHC P300F1...

Standard lengths are 10 ft and 5 m. To complete designation add chain length. For example, to order P95 in 10 ft length, use designation PHC P95X10FT.

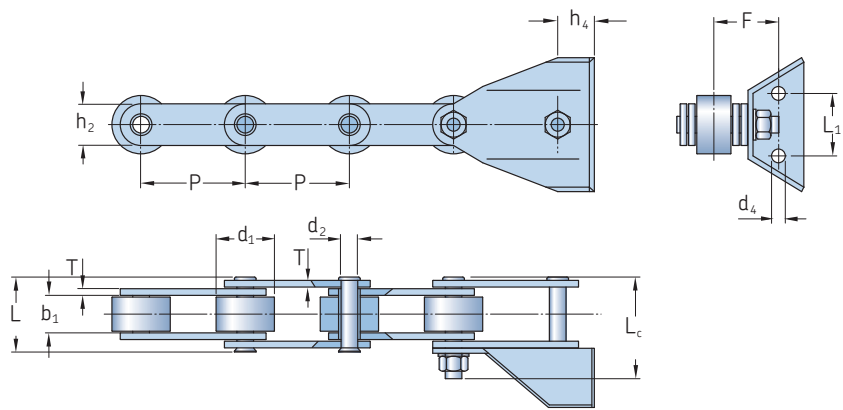

P125F6

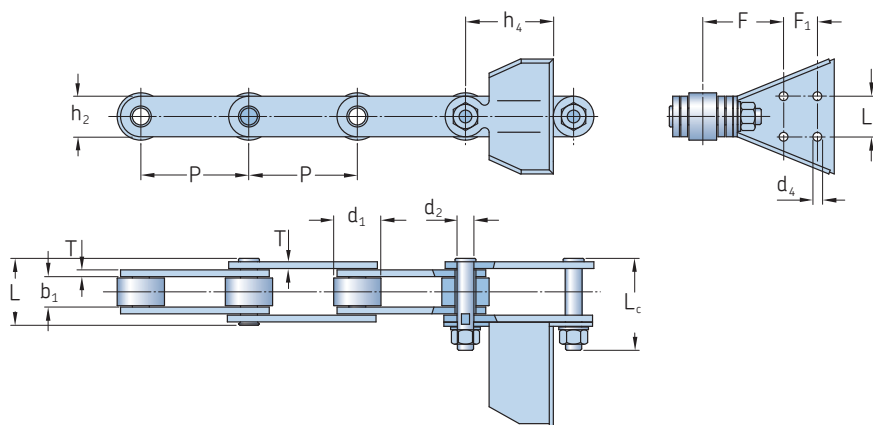

P160F7

Chain number	Dimensions				Pin length L Max.	Pin length L <sub>c</sub> Max.	Plate height h <sub>2</sub> Max.	L <sub>1</sub>	F	d <sub>4</sub>	h <sub>4</sub>	F <sub>1</sub>	Plate thickness T Max.	Ultimate tensile strength Q Min.	Designation
	Pitch P	Roller diameter d <sub>1</sub> Max.	Width between inner plates b <sub>1</sub> Min.	Pin diameter d <sub>2</sub> Max.											
-	mm													kN	-
P125F6	125	70	45	20	90	122	50	75	77,5	16,5	44	-	8	250	PHC P125F6...
P160F7	160	70	45	25	99	136	60	60	119,5	13,0	130	50	10	400	PHC P160F7...

Standard lengths are 10 ft and 5 m. To complete designation add chain length. For example, to order P125F6 in 10 ft length, use designation PHC P125F6X10FT.

## Roller chain with vulcanized elastomer

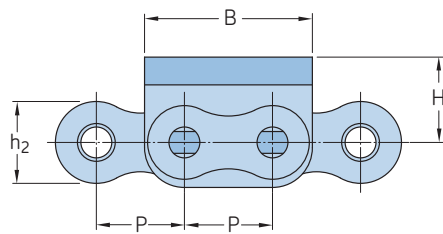

Type 1

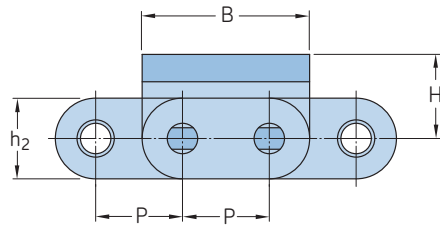
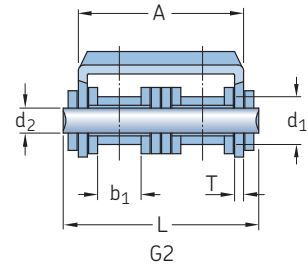
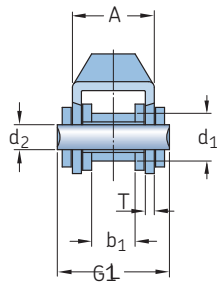

Type 2

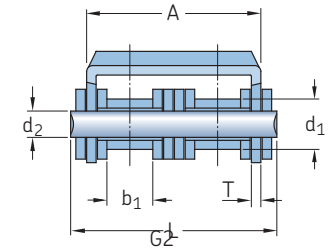
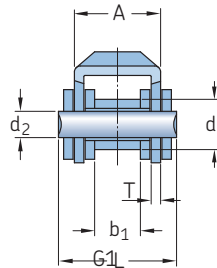

Type	Chain number	Dimensions			Pin diameter $d_2$ Max.	Pin length L Max.	Plate height $h_2$ Max.	Plate thickness T Max.	Attachment dimensions			Ultimate tensile strength Q Min.	Mass per meter q Kg/m	Designation	
		Pitch P	Roller diameter $d_1$ Max.	Width between inner plates $b_1$ Min.					A	B	H				
mm													kN	Kg/m	-
Type 1	08B-G1	12,700	8,51	7,75	4,45	20,00	11,80	1,60	14,6	24,2	12,30	18,0	1,19	PHC 08B-G1...	
Type 1	08B-G2	12,700	8,51	7,75	4,45	34,30	11,80	1,50	28,4	24,2	12,30	32,0	2,07	PHC 08B-G2...	
Type 1	10B-G1	15,875	10,16	9,65	5,08	23,20	14,70	1,60	16,8	30,0	17,00	19,0	1,62	PHC 10B-G1...	
Type 1	10B-G2	15,875	10,16	9,65	5,08	39,70	14,70	1,50	33,3	30,0	17,00	44,5	2,56	PHC 10B-G2...	
Type 1	12B-G1	19,050	12,07	11,68	5,72	25,70	16,00	1,85	19,6	36,0	21,00	29,0	2,01	PHC 12B-G1...	
Type 1	12B-G2	19,050	12,07	11,68	5,72	45,30	16,00	1,85	39,1	36,0	16,00	57,8	3,21	PHC 12B-G2...	
Type 1	12A-G1	19,050	11,91	12,57	5,94	29,90	18,00	1,85	21,4	37,1	21,00	31,8	2,55	PHC 12A-G1...	
Type 1	12AF1-G1	19,050	11,91	17,00	5,94	34,00	18,00	1,85	26,0	36,0	16,00	31,8	2,62	PHC 12AF1-G1...	
Type 1	16A-G1	25,400	15,88	15,75	7,92	37,20	24,00	2,42	27,5	46,0	20,00	42,0	3,97	PHC 16A-G1...	
Type 1	16A-G2	25,400	15,88	15,75	7,92	68,00	24,00	2,42	57,2	46,0	20,00	84,0	7,27	PHC 16A-G2...	
Type 1	16B-G1	25,400	15,88	17,02	8,28	39,70	21,00	1,60	29,1	49,0	21,40	58,0	3,83	PHC 16B-G1...	
Type 1	20A-G1	31,750	19,05	18,90	9,53	46,80	30,00	3,10	34,0	57,6	28,00	86,7	6,15	PHC 20A-G1...	
Type 1	20B-G1	31,750	19,05	19,56	10,19	48,00	26,40	3,50	36,0	57,0	27,00	85,0	6,19	PHC 20B-G1...	
Type 1	24B-G1	38,100	25,40	25,40	14,63	61,60	33,20	4,50	47,0	72,6	34,00	160,0	11,25	PHC 24B-G1...	
Type 2	C08B-G1	12,700	8,51	7,75	4,45	20,00	11,80	1,60	14,60	24,20	12,30	18,0	1,30	PHC C08B-G1...	
Type 2	C08B-G2	12,700	8,51	7,75	4,45	34,30	11,80	1,50	28,40	24,20	12,30	32,0	2,29	PHC C08B-G2...	
Type 2	C10B-G1	15,875	10,16	9,65	5,08	23,20	14,70	1,60	16,80	30,00	17,00	19,0	1,75	PHC C10B-G1...	
Type 2	C10B-G2	15,875	10,16	9,65	5,08	39,70	14,70	1,50	33,30	30,00	17,00	44,5	2,95	PHC C10B-G2...	
Type 2	C12B-G1	19,050	12,07	11,68	5,72	25,70	16,00	1,85	19,60	36,00	21,00	29,0	2,15	PHC C12B-G1...	
Type 2	C12B-G2	19,050	12,07	11,68	5,72	45,30	16,00	1,85	39,10	36,00	16,00	57,8	3,48	PHC C12B-G2...	
Type 2	C16A-G1	25,400	15,88	15,75	7,92	37,20	24,00	2,42	27,50	46,00	20,00	42,0	4,34	PHC C16A-G1...	
Type 2	C16B-G1	25,400	15,88	17,02	8,28	39,70	21,00	1,60	29,10	49,00	21,40	58,0	4,11	PHC C16B-G1...	
Type 2	C20B-G1	31,750	19,05	19,56	10,19	48,00	26,40	3,50	36,00	57,00	27,00	85,0	6,65	PHC C20B-G1...	
Type 2	C24B-G1	38,100	25,40	25,40	14,63	61,60	33,20	4,50	47,00	72,60	34,00	160,0	11,63	PHC C24B-G1...	

Standard lengths are 10 ft and 5 m. To complete designation add chain length. For example, to order 08B-G1 in 10 ft length, use designation PHC 08B-G1X10FT.

# Roller chain with vulcanized elastomer

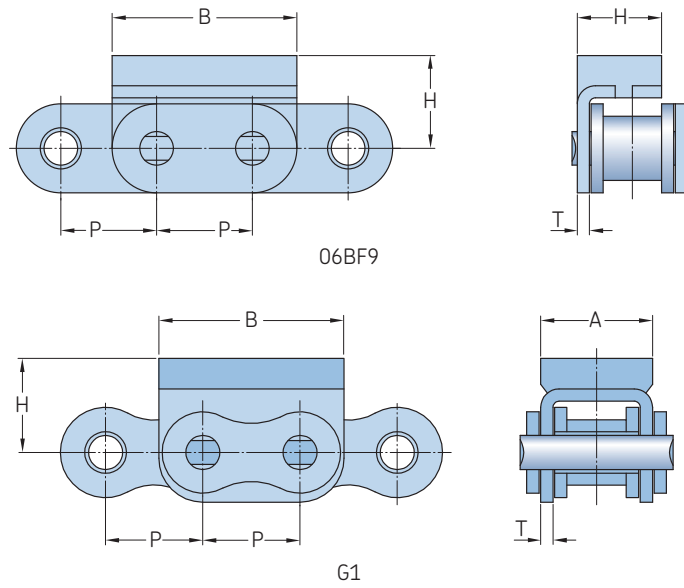

Chain number	Dimensions Pitch	Designation				
		P	A	B	H	T
-	mm	-	-	-	-	-
06BF9	9,525	17,73	9,0	9,05	1,3	PHC 06BF9...
08B-G1F1	12,700	18,00	24,2	12,30	1,6	PHC 08B-G1F1...
10B-G1F2	15,875	25,00	30,0	14,00	1,6	PHC 10B-G1F2...
10B-G1F3	15,875	20,00	30,0	18,00	1,6	PHC 10B-G1F3...

Standard lengths are 10 ft and 5 m. To complete designation add chain length. For example, to order 06BF9 in 10 ft length, use designation PHC 06BF9X10FT.

Roller chain with vulcanized elastomer

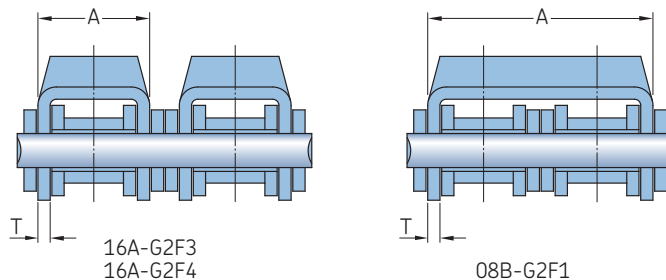
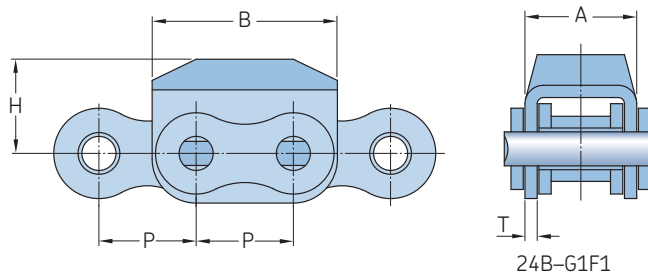
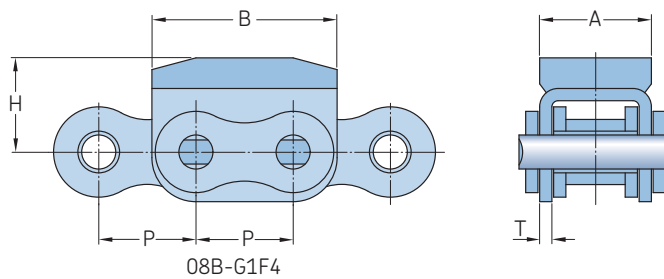

Chain number	Dimensions						Designation
	Pitch	A	B	H	T		
-	mm						-
08B-G1F4	12,7	18,0	24,2	12,3	1,60		PHC 08B-G1F4...
08B-G2F1	12,7	28,4	24,2	12,0	1,50		PHC 08B-G2F1...
16A-G2F3	25,4	27,5	49,0	21,4	2,42		PHC 16A-G2F3...
16A-G2F4	25,4	27,0	49,2	20,0	2,03		PHC 16A-G2F4...
24B-G1F1	38,1	27,0	72,0	34,0	4,50		PHC 24B-G1F1...

Standard lengths are 10 ft and 5 m. To complete designation add chain length. For example, to order 08B-G1F4 in 10 ft length, use designation PHC 08B-G1F4X10FT.



## Roller chain with vulcanized elastomer

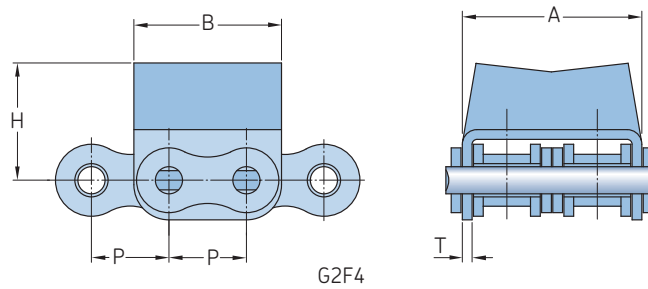
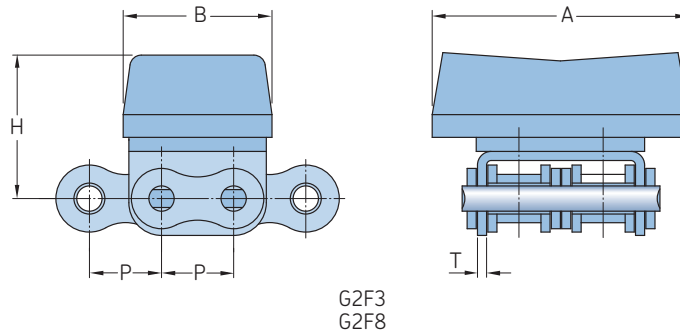
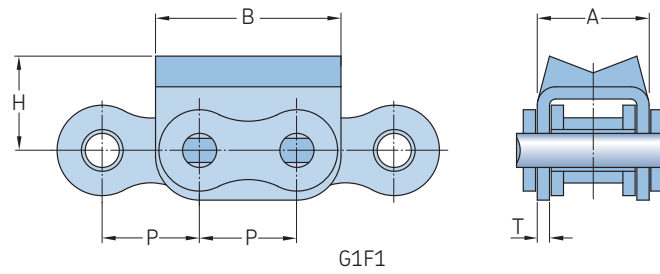

Chain number	Dimensions					Designation
	Pitch	A	B	H	T	
	P	A	B	H	T	
	mm					-
12B-G1F1	19,05	19,6	36	18,0	1,85	PHC 12B-G1F1...
12B-G2F3	19,05	77,0	37	36,0	1,85	PHC 12B-G2F3...
12B-G2F8	19,05	101,0	37	36,0	1,85	PHC 12B-G2F8...
12B-G2F4	19,05	39,1	36	27,5	1,85	PHC 12B-G2F4...

Standard lengths are 10 ft and 5 m. To complete designation add chain length. For example, to order 12B-G1F1 in 10 ft length, use designation PHC 12B-G1F1X10FT.

Roller chain with vulcanized elastomer

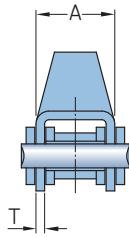
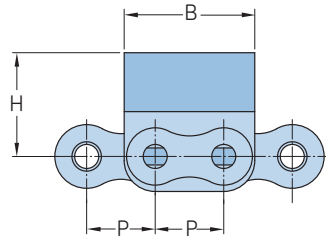

16A-G1F1

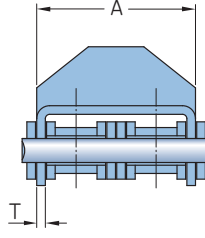

12B-G2F5

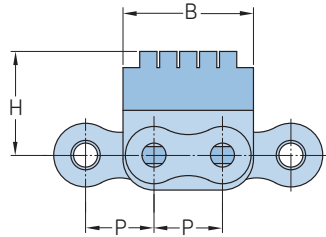

G2F6

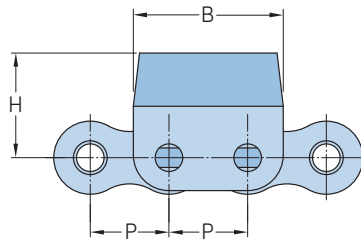
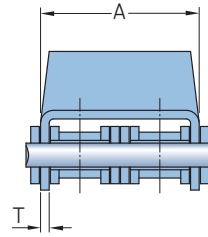

24A - G1F1

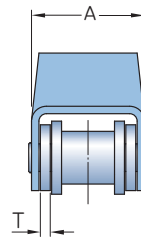

Chain number	Dimensions						Designation
	Pitch						
	P	A	B	H	T		
	mm						
12B-G2F5	19,05	39,10	36,0	28,0	1,85	PHC 12B-G2F5...	
16A-G1F1	25,40	27,50	46,0	21,4	2,42	PHC 16A-G1F1...	
24A-G1F1	38,10	55,50	70,0	46,5	4,80	PHC 24A-G1F1...	
12B-G2F6	19,05	39,01	37,3	28,2	1,85	PHC 12B-G2F6...	

Standard lengths are 10 ft and 5 m. To complete designation add chain length. For example, to order 12B-G2F5 in 10 ft length, use designation PHC 12B-G2F5X10FT.

## Roller chain with vulcanized elastomer

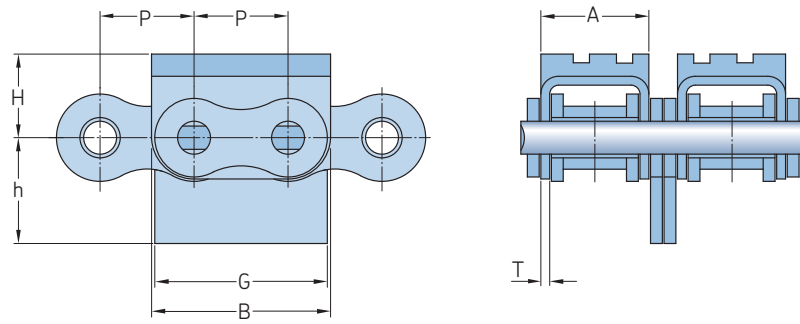

Chain number	Dimensions							Designation
	Pitch	A	B	G	h	H	T	
-	mm							-
16A-G2F1	25,4	27,0	49,2	45,4	25	20	2,03	PHC 16A-G2F1...

Standard lengths are 10 ft and 5 m. To complete designation add chain length. For example, to order 16A-G2F1 in 10 ft length, use designation PHC 16A-G2F1X10FT.

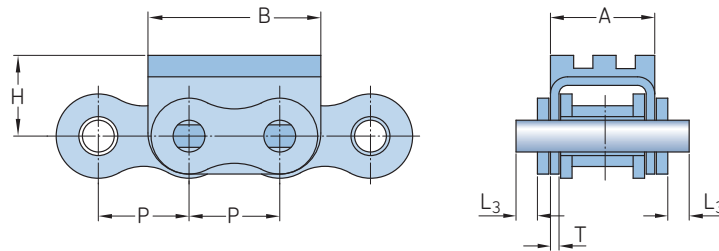

Chain number	Dimensions						Designation
	Pitch	A	B	L <sub>3</sub>	H	T	
-	mm						-
16A-G1F3	25,4	27,5	49	8,3	21,4	2,42	PHC 16A-G1F3...

Standard lengths are 10 ft and 5 m. To complete designation add chain length. For example, to order 16A-G1F3 in 10 ft length, use designation PHC 16A-G1F3X10FT.

## Steel agricultural series

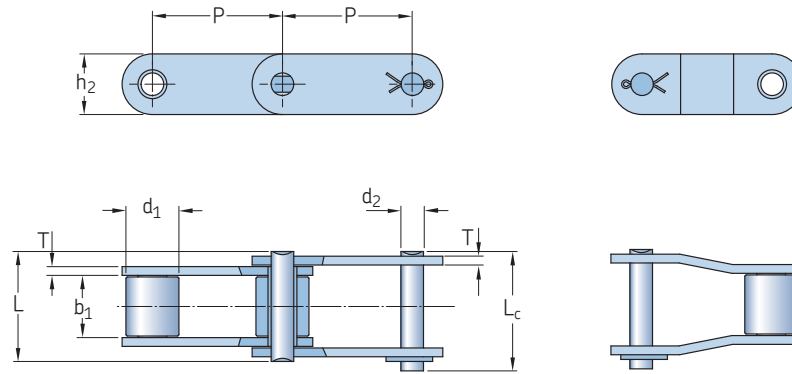

Chain number	Dimensions		Width between inner plates $b_1$ Min.	Pin diameter $d_2$ Max.	Pin length		Plate height $h_2$ Max.	Plate thickness $T$ Max.	Ultimate tensile strength $Q$ Min.	Average tensile strength $Q_0$	Mass per meter $q$	Designation
	Pitch $P$	Roller diameter $d_1$ Max.			$L$ Max.	$L_c$ Max.						
mm												
CAE44151	28,58	15,88	16,20	7,92	33,5	36,9	22,20	3,25	58,80	64,5	2,73	PHC CAE44151...
CA2060H	38,10	11,91	12,70	5,94	29,2	31,6	18,00	3,25	31,10	40,5	1,45	PHC CA2060H...
CA2063H	38,10	11,89	12,70	5,94	29,4	34,2	19,30	3,25	31,28	40,5	1,65	PHC CA2063H...
38.4R	38,40	15,88	19,05	6,92	33,8	36,4	17,30	2,50	33,00	41,2	1,70	PHC 38.4R...
38.4V	38,40	15,88	18,00	6,92	35,0	38,0	17,30	3,00	40,00	50,0	1,83	PHC 38.4V...
38.4VB	38,40	15,88	19,05	8,28	36,1	39,4	20,50	3,00	50,00	62,5	2,17	PHC 38.4VB...
55VD	41,40	17,90	23,00	8,22	39,3	42,4	20,00	2,80	42,00	45,0	2,34	PHC 55VD...
CA550	41,40	16,87	19,81	7,19	35,0	38,0	19,30	2,80	39,10	51,2	1,94	PHC CA550...
CA550F4	41,40	14,35	20,24	7,14	35,0	38,5	19,05	2,80	50,00	52,0	1,76	PHC CA550F4...
CA550F5	41,40	16,66	20,24	7,14	35,0	38,5	19,05	2,80	45,00	52,0	1,97	PHC CA550F5...
CA550V	41,40	16,80	19,05	8,28	36,1	39,1	22,00	3,00	55,00	68,7	2,24	PHC CA550V...
CA555	41,40	16,87	12,70	7,19	29,1	32,0	19,30	3,10	39,10	56,0	1,72	PHC CA555...
CA557	41,40	17,78	20,24	8,00	37,4	40,6	23,10	3,10	55,61	74,3	2,60	PHC CA557...
CA960	41,40	17,78	22,61	8,90	40,1	43,0	23,10	3,00	66,00	72,6	6,94	PHC CA960...
S62F3	41,91	19,05	25,40	8,00	42,0	44,6	26,00	3,00	47,00	58,7	3,12	PHC S62F3...
CA620	42,01	17,91	24,51	7,19	41,8	45,2	20,20	3,25	39,10	55,1	2,35	PHC CA620...

Standard lengths are 10 ft and 5 m. To complete designation add chain length. For example, to order CA550 in 10 ft length, use designation PHC CA550X10FT. Please, note chains are base chains only. Full range of attachments available, please, contact SKF.

## Steel agricultural series

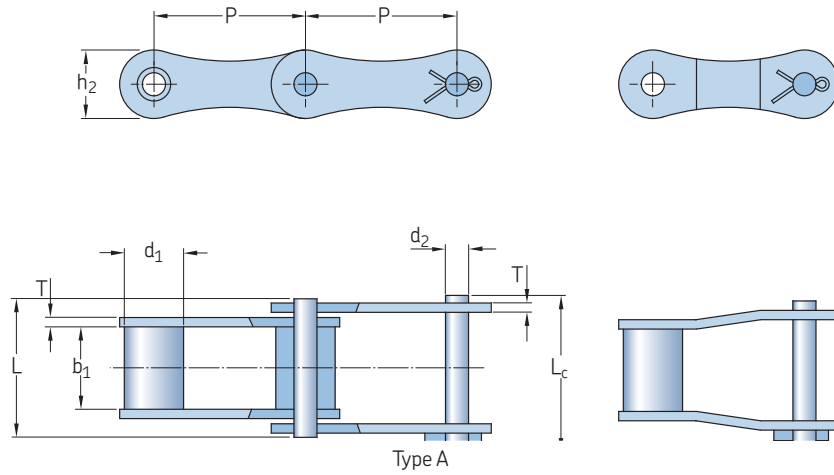

Chain number	Dimensions		Roller diameter $d_1$ Max.	Width between inner plates $b_1$ Min.	Pin diameter $d_2$ Max.	Pin length		Plate height $h_2$ Max.	Plate thickness $T$ Max.	Ultimate tensile strength $Q$ Min.	Average tensile strength $Q_0$	Mass per meter $q$	Designation
	Pitch $P$					$L$ Max.	$L_c$ Max.						
–	mm									kN		Kg/m	–
A550	41,40		16,87	19,81	7,19	35,0	38,0	19,3	2,80	39,10	51,2	1,79	PHC A550...
A555	41,40		16,87	12,70	7,19	29,1	32,0	19,3	3,10	39,10	56,0	1,60	PHC A555...
A557	41,40		17,78	20,24	8,00	37,4	40,6	23,1	3,10	55,61	74,3	2,45	PHC A557...
A620	42,01		17,91	24,51	7,19	41,8	45,2	20,2	3,25	39,10	55,1	2,18	PHC A620...

Standard lengths are 10 ft and 5 m. To complete designation add chain length. For example, to order A550 in 10 ft length, use designation PHCA550X10FT. Please, note chains are base chains only. Full range of attachments available, please, contact SKF.

## Steel agricultural series

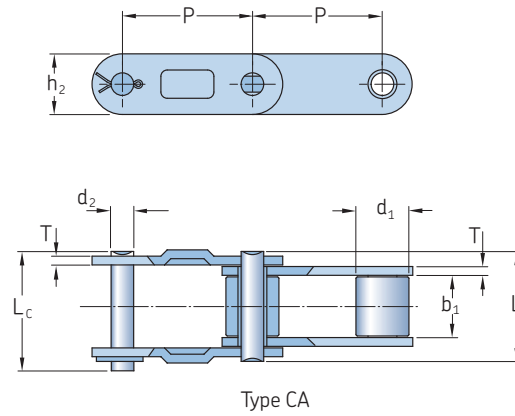

Type CA

Chain number	Dimensions		Width between inner plates $b_1$ Min.	Pin diameter $d_2$ Max.	Pin length		Plate height $h_2$ Max.	Plate thickness $T$ Max.	Ultimate tensile strength $Q$ Min.	Average tensile strength $Q_0$	Mass per meter $q$	Designation
	Pitch $P$	Roller diameter $d_1$ Max.			$L$ Max.	$L_c$ Max.						
–	mm								kN		Kg/m	–
CA627	30,00	15,88	19,05	8,28	36,1	39,1	20,5	3,00	50,00	55,0	2,51	PHC CA627...
CA550D	41,40	16,87	19,81	7,19	35,0	38,0	19,3	2,80	39,10	51,2	1,94	PHC CA550D...
CA555D	41,40	16,87	12,70	7,19	29,1	32,0	19,3	3,10	39,10	56,0	1,72	PHC CA555D...
CA557D	41,40	17,78	20,24	8,00	37,4	40,6	23,1	3,10	55,61	74,3	2,60	PHC CA557D...
CA620D	42,01	17,91	24,51	7,19	41,8	45,2	20,2	3,25	39,10	55,1	2,35	PHC CA620D...

Standard lengths are 10 ft and 5 m. To complete designation add chain length. For example, to order A550 in 10 ft length, use designation PHC A550X10FT. Please, note chains are base chains only. Full range of attachments available, please, contact SKF.

## Sharp top series

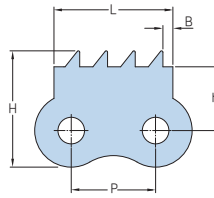

08B-940

Chain number	Dimensions					Designation
	Pitch	h	H	B	L	
-	mm					-
08B-940	12,7	9,6	17,5	1,5	17,9	PHC 08B-940...

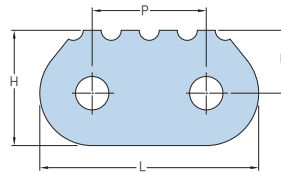

120-1802

Chain number	Dimensions				Designation
	Pitch	h	H	L	
-	mm				-
120-1802	38,10	21,00	38,60	73,1	PHC 120-1802...

Standard lengths are 10 ft and 5 m. To complete designation add chain length. For example, to order 120-1802 in 10 ft length, use designation PHC 120-18021X10FT.

Standard lengths are 10 ft and 5 m. To complete designation add chain length. For example, to order 08B-940 in 10 ft length, use designation PHC 08B-940X10FT.

Sharp top series

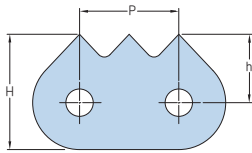

C16AF1 C16A-3PEP

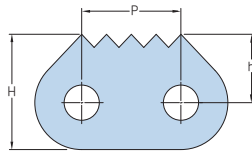

C16AF2 16A-1171

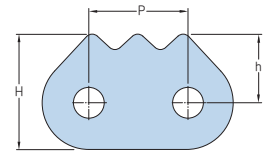

C60F2

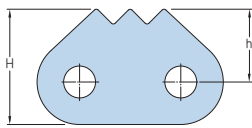

12B-910 60-910

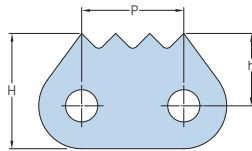

12BF3

Chain number	Dimensions			Designation
	Pitch	h	H	
-	mm			-
C60F2	19,05	13,38	22,48	PHC C60F2...
60-910	19,05	12,70	21,70	PHC 60-910...
12BF3	19,05	13,50	21,50	PHC 12BF3...
12B-910	19,05	13,70	21,70	PHC 12B-910...
C16AF1	25,40	17,50	29,50	PHC C16AF1...
C16AF2	25,40	17,50	29,50	PHC C16AF2...
C16A-3PEP	25,40	17,40	29,00	PHC C16A-3PEP...
16A-1171	25,40	16,00	26,40	PHC 16A-1171...

Standard lengths are 10 ft and 5 m. To complete designation add chain length. For example, to order C16AF1 in 10 ft length, use designation PHC C16AF1X10FT.



## Sharp top series

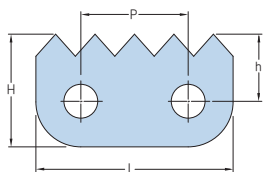

12B-911

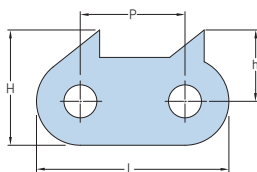

C12B-9010

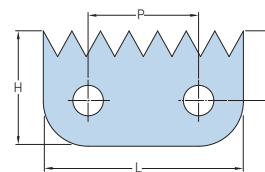

16B-1187

Chain number	Dimensions				Designation
	Pitch	P	h	H	
-	mm	-	-	-	-
12B-911	19,05	11,9	20,0	35,00	PHC 12B-911...
C12B-9010	19,05	13,0	21,0	19,05	PHC C12B-9010...
16B-1187	25,40	16,0	26,5	46,00	PHC 16B-1187...

Standard lengths are 10 ft and 5 m. To complete designation add chain length. For example, to order 12B-911 in 10 ft length, use designation PHC 12B-911

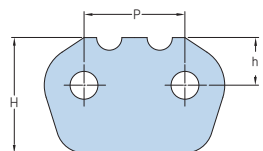

61BF45

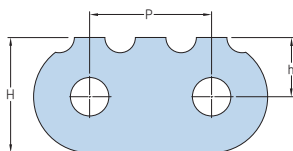

60-911

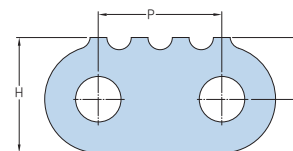

24B-1810

Chain number	Dimensions			Designation
	Pitch	P	h	
-	mm	-	-	-
60-911	19,05	9,25	18,00	PHC 60-911...
16BF45	25,40	12,00	29,00	PHC 16BF45...
24B-1810	38,10	19,00	35,5	PHC 24B-1810...

Standard lengths are 10 ft and 5 m. To complete designation add chain length. For example, to order 16BF45 in 10 ft length, use designation PHC 16BF45X10FT.

## Sharp top series

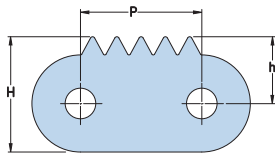

LL1044F1

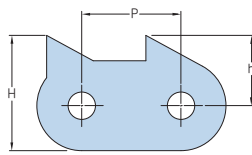

C16A-1160

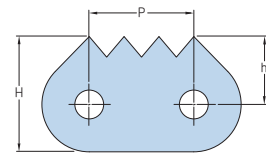

C16A-1170

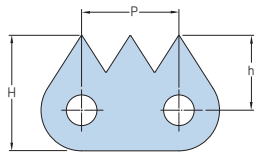

08BF71

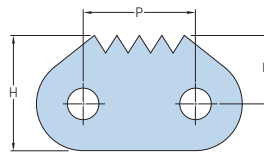

C20BF9

Chain number	Dimensions			Designation
	Pitch	h	H	
-	mm			-
08BF71	12,700	9,75	15,05	PHC 08BF71...
LL1044F1	15,875	8,73	15,08	PHC LL1044F1...
C116A-1160	25,400	18,00	29,50	PHC C116A-1160...
C116A-1170	25,400	16,50	28,00	PHC C116A-1170...
C20BF9	31,750	19,80	33,00	PHC C20BF9...

Standard lengths are 10 ft and 5 m. To complete designation add chain length. For example, to order 08BF71 in 10 ft length, use designation PHC 08BF71X10FT.

## Sharp top series

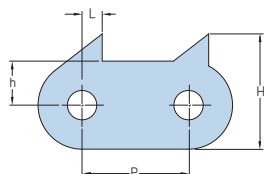

C16B-1160

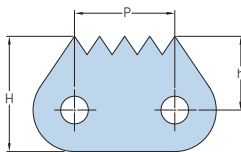

C16BF2

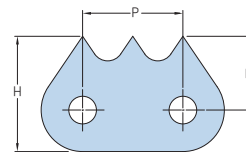

C16BF3

Chain number	Dimensions				Designation
	Pitch	h	H	L	
-	mm				-
C16B-1160	25,4	10,5	27,5	4,8	PHC C16B-1160...
C16B-1161	25,4	10,5	27,5	6,0	PHC C16B-1161...
C16BF2	25,4	-	27,5	29,2	PHC C16BF2...
C16BF3	25,4	-	18,7	29,2	PHC C16BF3...

Standard lengths are 10 ft and 5 m. To complete designation add chain length. For example, to order C16B-1160 in 10 ft length, use designation PHC C16B-1160X10FT.

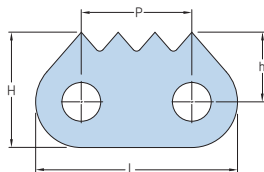

16B-1170 16B-1172

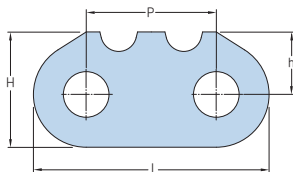

16B-1180

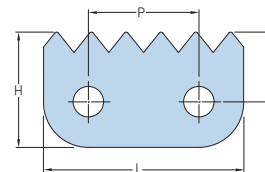

16B-1185

Chain number	Dimensions				Designation
	Pitch	h	H	L	
-	mm				-
16B-1170	25,4	46,1	16,0	26,5	PHC 16B-1170...
16B-1180	25,4	46,0	12,2	22,5	PHC 16B-1180...
16B-1172	25,4	46,1	15,0	25,5	PHC 16B-1172...
16B1185	25,4	46,0	16,0	26,5	PHC 16B1185...

Standard lengths are 10 ft and 5 m. To complete designation add chain length. For example, to order C16BF2 in 10 ft length, use designation PHC C16BF2X10FT.

## Sharp top series

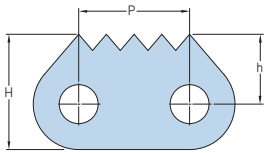

16BF24

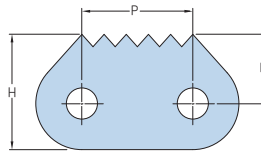

20B-1310

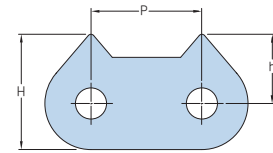

20B-1350

Chain number	Dimensions			Designation
	Pitch	h	H	
–	P	h	H	–
–	mm			–
16BF24	25,40	16,0	26,4	PHC 16BF24...
16BF29	25,40	15,9	26,4	PHC 16BF29...
20B-1310	31,75	19,8	33,0	PHC 20B-1310...
20B-1350	31,75	19,8	33,0	PHC 20B-1350...

Standard lengths are 10 ft and 5 m. To complete designation add chain length. For example, to order 16BF24 in 10 ft length, use designation PHC 16BF24X10FT.

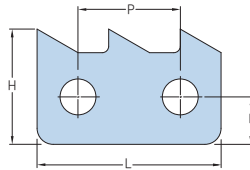

20AF1

Chain number	Dimensions				Designation
	Pitch	h	H	L	
–	P	h	H	L	–
–	mm				–
20AF1	31,75	14,75	35,84	57,2	PHC 20AF1...

Standard lengths are 10 ft and 5 m. To complete designation add chain length. For example, to order 20AF1 in 10 ft length, use designation PHC 20AF1X10FT.

## Sharp top series

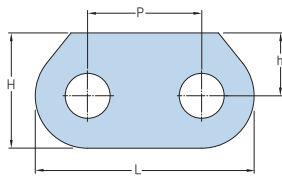

24B-1805

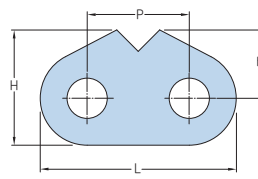

24B-1807

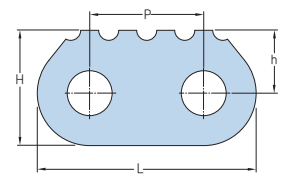

24B-1809

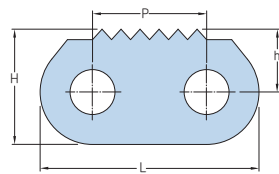

C24B-1820

Chain number	Dimensions				Designation
	Pitch	h	H	L	
-	mm				-
24B-1805	38,1	21,0	38,5	73,1	PHC 24B-1805...
24B-1807	38,1	25,5	43,0	73,1	PHC 24B-1807...
24B-1809	38,1	21,0	38,5	73,1	PHC 24B-1809...
C24B-1820	38,1	21,0	38,5	73,1	PHC C24B-1820...

Standard lengths are 10 ft and 5 m. To complete designation add chain length. For example, to order 24B-1805 in 10 ft length, use designation PHC 24B-1805X10FT.

## Sharp top series

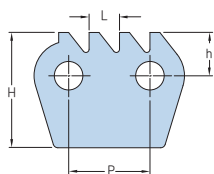

32B-1875

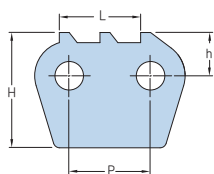

32B-1876

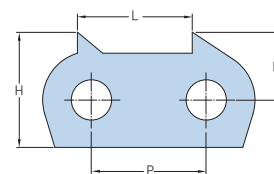

32B-1877

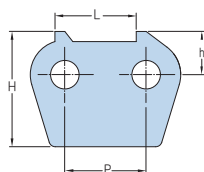

32B-1878

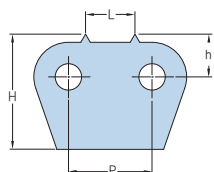

32BF4

Chain number	Dimensions				Designation
	Pitch	h	H	L	
–	mm				–
32B-1875	50,80	72,00	19,00	27,00	PHC 32B-1875...
32B-1876	50,80	72,00	50,80	27,00	PHC 32B-1876...
32B-1877	50,80	51,00	50,80	30,00	PHC 32B-1877...
32B-1878	50,80	27,00	72,00	50,80	PHC 32B-1878...
32BF4	50,8	26,0	70,0	30,0	PHC 32BF4...

Standard lengths are 10 ft and 5 m. To complete designation add chain length. For example, to order 32B-1875 in 10 ft length, use designation PHC 32B-1875X10FT.

## Sharp top series

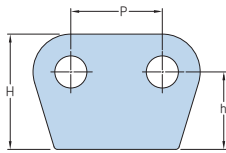

32B-1872

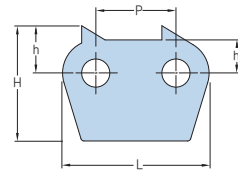

32B-1874

Chain number	Dimensions						Designation
	Pitch	$h_1$	$h$	$H$	$L$		
-	mm						-
32B-1872	50,8	-	43	64	92,8		PHC 32B-1872...
32B-1874	50,8	21	30	73	92,8		PHC 32B-1874...

Standard lengths are 10 ft and 5 m. To complete designation add chain length. For example, to order 32B-1872 in 10 ft length, use designation PHC 32B-1872X10FT.

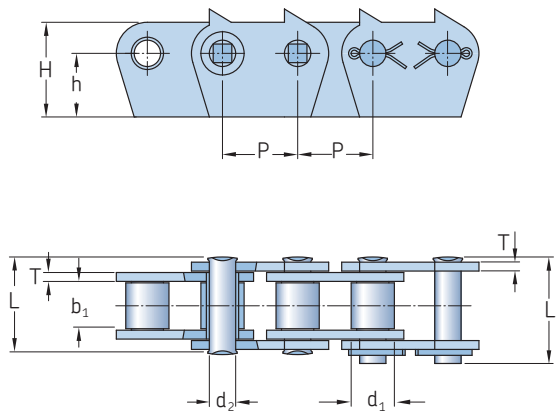

Chain number	Dimensions				Pin length		Plate thickness	Ultimate tensile strength	Average tensile strength	Mass per meter	Designation
	Pitch	Roller diameter	Width between inner plates	Pin diameter	$L$	$L_c$					
-	mm	$d_1$ Max.	$b_1$ Min.	$d_2$ Max.	$L$ Max.	$L_c$ Max.	$T$ Max.	$Q$ Min.	$Q_0$	$q$	-
32B-1-1872	50,8	29,21	33	17,81	66	71	6	250	275	13,54	PHC 32B-1-1872...

Standard lengths are 10 ft and 5 m. To complete designation add chain length. For example, to order 32B-1-1872 in 10 ft length, use designation PHC 32B-1-1872X10FT.

## Sharp top series

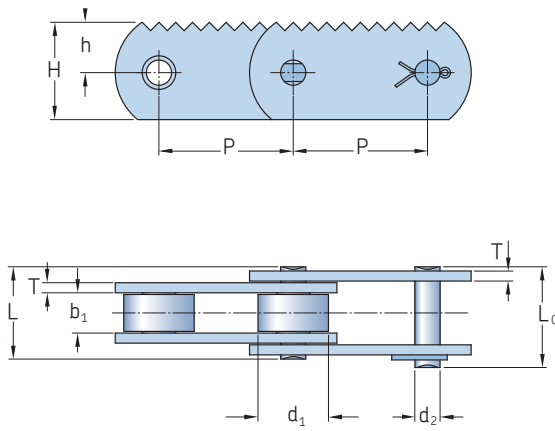

Chain number	Dimensions		Width between inner plates $b_1$ Min.	Pin diameter $d_2$ Max.	Pin length		$h$	$H$	Plate thickness $T$ Max.	Ultimate tensile strength $Q$ Min.	Average tensile strength $Q_0$	Mass per meter $q$	Designation
	Pitch $P$	Roller diameter $d_1$ Max.			$L$ Max.	$L_c$ Max.							
–	mm										kN	Kg/m	–
<b>P80</b>	80	42	24	15	55	60	30	58	6	250	275	11,3	<b>PHC P80...</b>

Standard lengths are 10 ft and 5 m. To complete designation add chain length. For example, to order P80 in 10 ft length, use designation PHC P80X10FT.

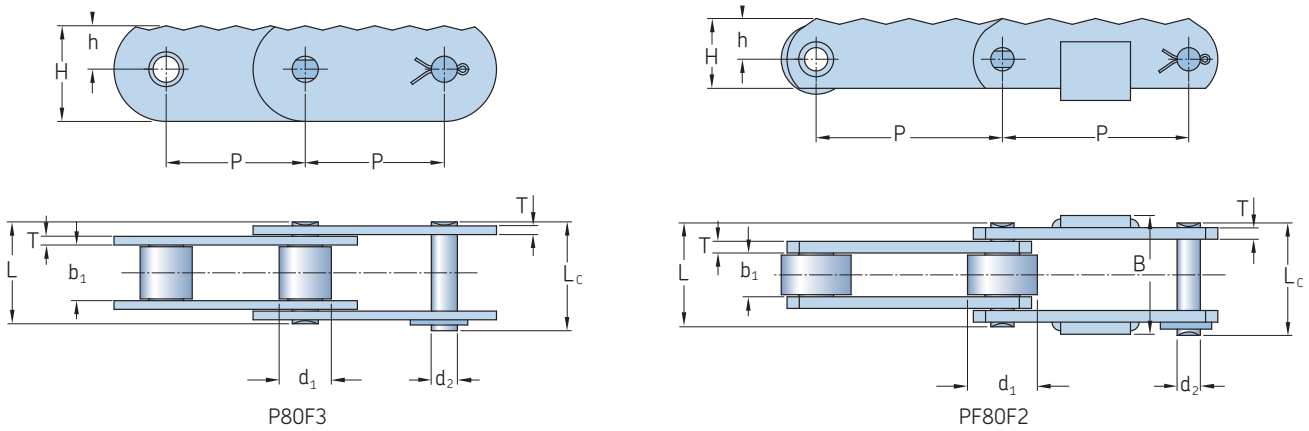

Chain number	Dimensions		Width between inner plates		Pin diameter $d_2$ Max.	Pin length		$h$	$H$	Plate thickness $T$ Max.	Ultimate tensile strength $Q$ Min.	Average tensile strength $Q_0$	Mass per meter $q$	Designation
	Pitch $P$	Roller diameter $d_1$ Max.	$b_1$ Min.	$B$		$L$ Max.	$L_c$ Max.							
–	mm										kN	Kg/m	–	
<b>P80F3</b>	80	30	32	–	15	58,6	62,6	25	55	5	98,00	107	9,12	<b>PHC P80F3...</b>
<b>P80F2</b>	80	30	18	51	10	44,6	48,3	17,5	30	5	61,74	70	4,15	<b>PHC P80F2...</b>

Standard lengths are 10 ft and 5 m. To complete designation add chain length. For example, to order P80F3 in 10 ft length, use designation PHC P80F3X10FT.



## Hollow pin series

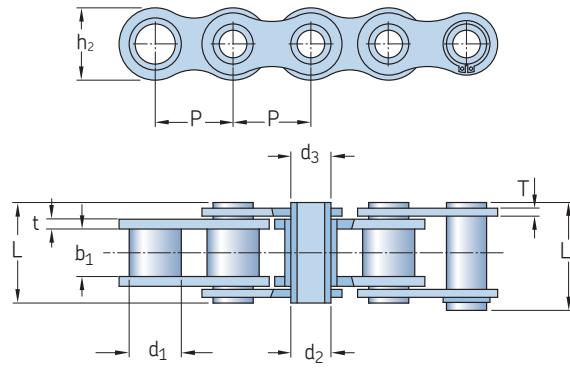

Chain number	Dimensions			Pin diameter		Pin length		Inner plate height $h_2$ Max.	Plate thickness		Ultimate tensile strength Q Min.	Average tensile strength $Q_0$	Mass per meter q	Designation
	Pitch P	Bush diameter $d_1$ Max.	Width between outer plates $b_1$ Min.	$d_2$ Max.	$d_3$ Max.	L Max.	$L_c$ Max.		t	T				
mm											kN	Kg/m	-	
08BHPF	12,700	8,51	7,75	6,55	4,50	16,4	17,6	11,80	1,60	1,30	11,10	12,1	0,56	PHC 08BHPF...
08BHPF5	12,700	8,51	7,75	6,30	4,50	16,8	18,0	12,00	1,60	1,60	9,60	10,6	0,62	PHC 08BHPF5...
10BHPF3	15,875	10,16	9,65	7,02	5,13	19,5	20,5	14,70	1,70	1,70	10,00	11,5	0,86	PHC 10BHPF3...
10BHPF4	15,875	10,16	9,50	7,20	5,00	19,8	21,3	14,00	2,03	1,60	12,50	14,0	0,82	PHC 10BHPF4...
12BHPF2	19,050	12,07	11,68	8,09	6,00	22,7	23,9	16,10	1,85	1,85	14,00	16,0	0,82	PHC 12BHPF2...
12BHPF3	19,050	12,07	11,70	8,22	5,75	23,6	24,9	16,20	2,42	1,85	16,00	18,0	1,14	PHC 12BHPF3...
16BHPF3	25,400	15,88	17,02	11,50	8,20	35,3	37,0	23,20	4,00	3,10	49,00	52,2	2,26	PHC 16BHPF3...
16BHPF4	25,400	11,70	13,50	8,00	4,30	28,9	30,2	21,30	3,00	3,00	30,00	33,0	1,81	PHC 16BHPF4...
40HP	12,700	7,95	7,85	5,63	4,00	16,5	17,6	12,00	1,50	1,50	11,00	12,2	0,54	PHC 40HP...
50HP	15,875	10,16	9,40	7,03	5,13	20,7	21,9	15,09	2,03	2,03	20,00	22,6	0,91	PHC 50HP...
50HPF4	15,875	10,16	8,80	7,03	5,13	19,9	21,1	15,09	2,03	2,03	18,00	19,2	0,89	PHC 50HPF4...
60HP	19,050	11,91	12,70	8,31	6,00	25,8	26,8	18,00	2,42	2,42	24,00	26,9	1,29	PHC 60HP...
60HPF1	19,050	11,91	12,70	8,31	5,01	25,5	26,8	18,00	2,42	2,42	28,00	30,9	1,37	PHC 60HPF1...
80HP	25,400	15,88	15,75	11,40	8,05	32,5	33,8	24,00	3,25	3,25	50,00	52,0	2,26	PHC 80HP...
80HPF1	25,400	11,70	13,50	7,80	4,00	27,0	28,4	21,50	2,42	2,42	27,44	29,3	1,50	PHC 80HPF1...
80HPF2	25,400	15,88	15,75	11,40	8,40	32,5	33,8	24,00	3,25	3,25	45,00	48,0	2,23	PHC 80HPF2...
A2080HP	50,800	15,88	15,75	11,40	8,05	32,4	33,8	24,00	3,25	3,25	42,30	46,1	1,60	PHC A2080HP...

Standard lengths are 10 ft and 5 m. To complete designation add chain length. For example, to order 08BHPF in 10 ft length, use designation PHC 08BHPFX10FT.

## Hollow pin series

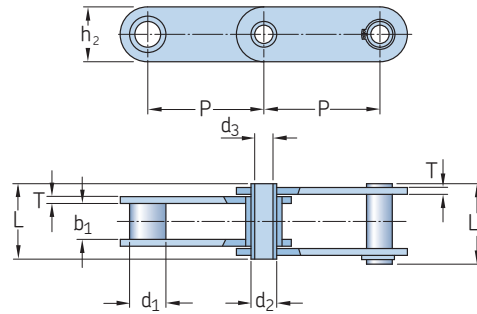

Chain number	Dimensions			Pin diameter		Pin length		Inner plate height $h_2$ Max.	Plate thickness T	Ultimate tensile strength Q Min.	Average tensile strength $Q_0$	Mass per meter q	Designation
	Pitch P	Bush diameter $d_1$ Max.	Width between outer plates $b_1$ Min.	$d_2$ Max.	$d_3$ Max.	L Max.	$L_c$ Max.						
	mm										kN	Kg/m	-
C2040HP	25,40	7,95	7,85	5,63	4,00	16,50	17,60	12,00	1,50	11,00	12,60	0,46	PHC C2040HP...
C2040HPF1	25,40	7,95	7,85	5,63	M4	16,50	17,60	12,00	1,50	9,00	9,90	0,44	PHC C2040HPF1...
C2050HP	31,75	10,16	9,40	7,22	5,12	20,50	21,80	15,00	2,03	20,40	22,80	0,76	PHC C2050HP...
C2060HP	38,10	11,91	12,70	8,31	6,00	25,80	26,80	17,00	2,42	24,00	27,10	1,02	PHC C2060HP...
HP40F1	40,00	18,00	22,00	12,00	8,00	47,50	48,20	35,00	5,00	57,00	63,80	5,38	PHC HP40F1...
HP40F2	40,00	18,00	22,00	12,00	8,20	47,50	48,20	35,00	5,00	57,00	63,00	5,37	PHC HP40F2...
C2080HP	50,80	15,88	15,75	11,40	8,05	32,50	33,80	24,00	3,25	50,00	52,00	1,81	PHC C2080HP...
HP50F1	50,00	26,00	14,50	20,00	14,70	35,30	36,20	40,00	3,10	30,00	33,60	3,98	PHC HP50F1...
C40HP	12,70	7,95	7,85	5,63	4,00	16,50	17,60	12,00	1,50	11,00	12,20	0,64	PHC C40HP...
C50HP	15,88	10,16	9,40	7,03	5,13	20,70	21,90	15,09	2,03	20,00	22,60	1,05	PHC C50HP...
C60HP	19,05	11,91	12,70	8,31	6,00	25,80	26,80	18,00	2,42	24,00	26,90	1,52	PHC C60HP...
C80HP	25,40	15,88	15,75	11,40	8,05	32,50	33,80	24,00	3,25	50,00	52,00	2,63	PHC C80HP...
C08BHP	12,70	8,51	7,75	6,55	4,50	16,40	17,60	11,80	1,60	11,00	11,50	0,62	PHC C08BHP...
HP12.5	12,50	8,51	8,20	6,65	4,50	16,40	17,60	11,60	1,50	8,00	8,80	0,61	PHC HP12.5...
HP50F7	50,00	18,00	15,00	14,00	10,20	36,00	37,50	26,00	4,00	40,00	43,20	2,56	PHC HP50F7...
HP50F10	50,00	18,00	22,00	12,10	8,30	39,50	40,60	30,00	3,00	45,00	48,00	2,73	PHC HP50F10...
HP55	55,00	18,00	22,00	14,00	10,00	43,40	44,50	30,00	4,00	50,00	52,00	3,31	PHC HP55...

Standard lengths are 10 ft and 5 m. To complete designation add chain length. For example, to order 08BHPF in 10 ft length, use designation PHC 08BHPF10FT.

## Hollow pin series

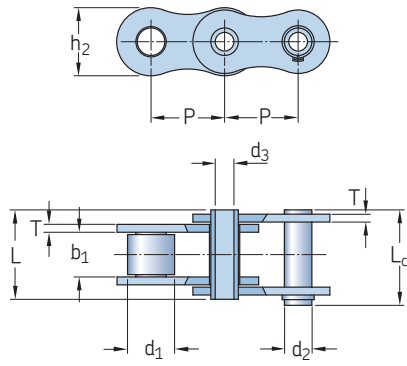

Type A

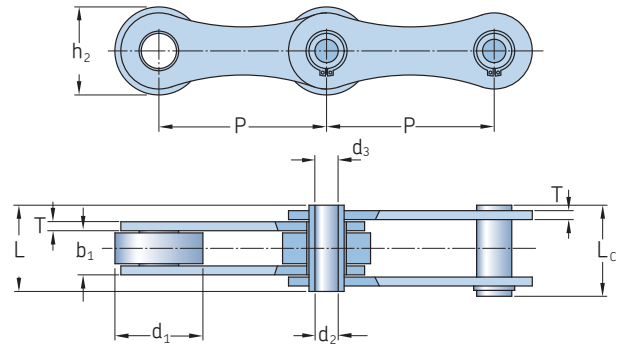

Type B

Type	Chain number	Dimensions		Width between inner plates b <sub>1</sub> Min.	Pin diameter		Pin length		Inner plate height h <sub>2</sub> Max.	Plate thickness T	Ultimate tensile strength Q Min.	Average tensile strength Q <sub>a</sub>	Mass per meter q	Designation
		Pitch P	Roller diameter d <sub>1</sub> Max.		d <sub>2</sub> Max.	d <sub>3</sub> Max.	L Max.	L <sub>c</sub> Max.						
		mm												
A	HP25.4	25,400	20,00	8,00	8,00	5,20	19,5	20,5	17,00	2,03	25,00	28,0	1,30	PHC HP25.4...
A	HP35	35,000	20,00	16,00	13,35	10,20	30,4	31,6	26,30	2,50	23,52	26,4	2,02	PHC HP35...
A	HB35	35,000	20,00	16,00	14,00	10,20	32,0	33,5	38,10	3,00	40,00	45,0	2,39	PHC HB35...
B	HB38.1	38,100	20,00	8,00	8,00	5,30	19,6	20,7	17,30	2,03	28,00	28,8	0,98	PHC HB38.1...
B	HB38.1F1	38,100	20,00	18,00	10,50	5,10	39,0	40,3	22,00	4,00	60,00	64,3	2,59	PHC HB38.1F1...
B	HB38.1F3	38,100	25,40	12,70	12,00	8,30	27,0	28,6	38,10	2,50	25,00	28,8	1,51	PHC HB38.1F3...
B	HB38.1F4	38,100	20,00	12,70	8,00	5,20	26,0	27,2	17,00	2,42	24,00	26,9	1,48	PHC HB38.1F4...
B	HB40F4	40,000	26,00	10,00	11,40	8,20	26,5	28,0	24,00	3,00	50,00	56,7	2,20	PHC HB40F4...
A	HP41.75	41,750	17,10	20,20	11,11	8,20	35,7	39,0	21,65	3,10	26,50	29,2	1,60	PHC HP41.75...
A	HP41.75F2	41,750	17,10	20,20	11,11	8,20	35,7	41,0	25,26	3,10	49,00	54,8	2,04	PHC HP41.75F2...
A	HP41.75F3	41,750	17,00	20,50	11,00	8,30	36,0	39,5	21,40	3,00	27,00	28,0	1,62	PHC HP41.75F3...
B	HP50F2	50,000	31,00	15,00	13,20	10,20	36,5	38,0	25,00	4,00	40,00	43,2	3,40	PHC HP50F2...
B	HB50	50,000	30,00	10,50	11,40	8,20	27,4	28,6	26,00	3,10	50,00	53,6	2,23	PHC HB50...
B	HB50.8	50,800	30,00	10,50	11,40	8,20	27,4	28,6	26,00	3,10	50,00	53,6	2,56	PHC HB50.8...
B	HB50.8F4	50,800	30,00	10,50	13,60	8,20	27,4	28,9	26,00	3,10	42,00	48,2	2,28	PHC HB50.8F4...
B	HB63	63,000	30,00	10,00	11,40	8,10	26,7	28,1	26,50	3,10	50,00	53,6	2,07	PHC HB63...
B	HB63F1	63,000	40,00	10,00	11,40	8,10	26,7	28,1	26,50	3,10	50,00	53,6	2,27	PHC HB63F1...
B	HB63F2	63,000	40,00	20,00	11,40	8,10	36,7	28,1	26,50	3,10	50,00	53,6	3,20	PHC HB63F2...
B	HB63F3	63,000	40,00	15,00	11,40	8,20	35,6	37,0	26,50	4,00	35,00	38,5	3,90	PHC HB63F3...
B	HB63F4	63,000	30,00	20,00	11,40	8,10	27,4	36,7	38,10	3,10	50,00	53,6	2,97	PHC HB63F4...
B	HB63F6	63,000	30,00	10,00	11,70	8,20	26,7	28,1	26,50	3,10	50,00	56,7	2,08	PHC HB63F6...
B	HB63F7	63,000	40,00	18,00	14,00	10,20	38,0	39,5	28,00	4,00	50,00	56,7	4,26	PHC HB63F7...
B	HB63F8	63,000	30,00	20,00	11,70	8,10	36,5	38,0	26,50	3,10	50,00	56,7	2,91	PHC HB63F8...
B	HB100	100,000	30,00	10,50	11,40	8,20	27,4	28,6	26,00	3,10	50,00	53,6	1,56	PHC HB100...
A	HP12.7	12,700	8,51	13,40	6,65	4,10	19,0	20,2	11,80	1,70	14,00	16,8	0,69	PHC HP12.7...

Standard lengths are 10 ft and 5 m. To complete designation add chain length. For example, to order HP25.4 in 10 ft length, use designation PHC HP25.4X10FT.

## Hollow pin series

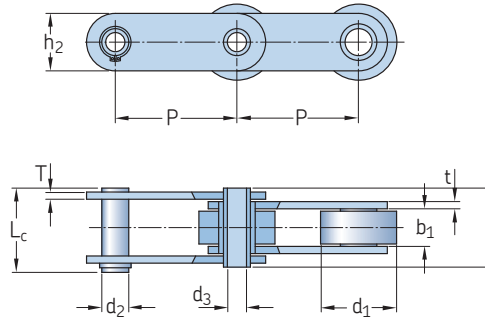

Chain number	Dimensions		Width between inner plates b <sub>1</sub> Min.	Pin diameter		Pin length		Plate height h <sub>2</sub> Max.	Plate thickness		Ultimate tensile strength Q Min.	Average tensile strength Q <sub>a</sub>	Mass per meter q	Designation
	Pitch P	Roller diameter d <sub>1</sub> Max.		d <sub>2</sub> Max.	d <sub>3</sub> Max.	L Max.	L <sub>c</sub> Max.		t	T				
–	mm										kN		Kg/m	–
C2042HP	25,40	15,88	7,85	5,63	4,00	16,5	17,6	12,0	1,50	1,50	11,0	12,6	0,78	PHC C2042HP...
C2052HP	31,75	19,05	9,53	7,22	5,12	20,5	21,8	15,0	2,03	2,03	20,4	22,8	1,25	PHC C2052HP...
C2062HP	38,10	22,23	12,70	8,31	6,00	25,8	26,8	17,0	2,42	2,42	24,0	27,1	1,72	PHC C2062HP...
C2082HP	50,80	28,58	15,75	11,40	8,05	32,4	33,8	24,0	3,25	3,25	50,0	52,0	2,82	PHC C2082HP...
C2042H-HP	25,40	15,88	7,85	5,63	4,00	18,8	19,9	12,0	2,03	2,03	11,0	13,2	0,95	PHC C2042H-HP...
C2052HPF1	31,75	19,05	9,40	7,03	5,12	20,0	21,5	15,3	1,85	1,85	15,0	17,3	1,21	PHC C2052HPF1...
C2052HPF3	31,75	19,05	9,53	7,02	5,13	20,1	21,6	15,1	2,03	2,03	19,6	21,6	1,20	PHC C2052HPF3...
C2052H-HP	31,75	19,05	9,53	7,22	5,12	22,1	23,4	15,0	2,42	2,42	20,4	23,5	1,44	PHC C2052H-HP...
C2062H-HP	38,10	22,23	12,70	8,31	6,00	29,2	30,2	17,0	3,25	3,25	24,0	27,6	1,99	PHC C2062H-HP...
C2082H-HP	50,80	28,58	15,75	11,40	8,05	35,7	37,0	24,0	4,00	4,00	50,0	56,5	3,34	PHC C2082H-HP...
HP40	40,00	22,00	8,75	9,00	6,00	23,0	24,2	18,0	2,50	2,50	27,0	28,0	1,49	PHC HP40...
HB40F1	40,00	22,00	9,00	9,00	6,00	23,0	24,5	18,0	2,50	2,50	20,0	22,0	1,58	PHC HB40F1...
HP41.4	41,40	25,40	15,00	13,80	10,50	35,5	37,0	32,0	4,00	4,00	45,0	48,0	4,20	PHC HP41.4...
HP50	50,00	31,00	14,50	13,20	10,40	31,1	32,5	25,0	3,10	3,10	30,0	34,2	3,29	PHC HP50...
HP50F4	50,00	31,00	15,00	13,20	10,20	36,5	38,0	25,0	4,00	4,00	40,0	44,8	3,73	PHC HP50F4...
HB50	50,00	31,00	15,00	14,00	10,20	36,0	37,5	25,0	4,00	4,00	40,0	43,2	3,98	PHC HB50...
HB50.8F8	50,80	32,00	20,00	19,10	12,40	44,6	46,4	40,0	5,00	4,00	100,0	108,0	6,75	PHC HB50.8F8...
C1655HP	50,80	30,00	10,50	13,00	8,20	27,4	28,9	26,0	3,10	3,10	42,0	48,2	2,72	PHC C1655HP...
HP50.8	50,80	26,00	15,88	20,00	14,30	41,0	42,2	38,1	4,80	4,80	100,0	108,0	5,32	PHC HP50.8...
HB50.8F9	50,80	35,00	12,00	15,50	10,20	36,0	37,3	30,0	5,00	5,00	70,0	77,0	4,92	PHC HB50.8F9...
HP63	63,00	40,00	15,00	16,00	12,10	35,0	36,2	28,5	4,00	4,00	50,0	56,7	4,20	PHC HP63...
DH4202HP	50,80	31,80	15,00	14,00	10,10	36,3	39,0	26,0	3,80	3,80	42,0	51,6	3,75	PHC DH4202HP...
DH4203HP	76,20	31,80	15,00	14,00	10,10	36,3	39,0	26,0	3,80	3,80	42,0	47,1	3,01	PHC DH4203HP...
DH42035HP	88,90	31,80	15,00	14,00	10,10	36,3	39,0	26,0	3,80	3,80	42,0	51,1	2,79	PHC DH42035HP...
DH4204HP	101,60	31,80	15,00	14,00	10,10	36,3	39,0	26,0	3,80	3,80	42,0	51,6	2,63	PHC DH4204HP...
DH8403HP	76,20	47,60	19,00	19,05	13,60	43,8	46,3	39,0	5,10	3,80	84,3	130,3	6,81	PHC DH8403HP...
DH8404HP	101,60	47,60	19,00	19,05	13,60	43,8	46,3	39,0	5,10	3,80	84,3	130,3	5,78	PHC DH8404HP...
DH8406HP	152,40	47,60	19,00	19,05	13,60	43,8	46,3	39,0	5,10	3,80	84,0	130,3	5,18	PHC DH8406HP...
HP38.1F2	38,10	25,40	12,70	9,50	6,60	26,6	28,0	19,1	2,30	2,30	20,0	22,4	2,07	PHC HP38.1F2...
HB50.8F3	50,80	30,00	16,00	14,00	9,00	36,4	37,5	25,5	3,10	3,10	42,0	47,0	3,20	PHC HB50.8F3...
HP75	75,00	40,00	22,00	18,00	12,20	42,0	44,0	35,0	4,00	4,00	60,0	72,0	5,57	PHC HP75...
HP76.2	76,20	31,75	15,50	12,70	9,50	35,5	37,0	26,0	4,00	4,00	42,0	49,2	3,25	PHC HP76.2...
HB76.2F2	76,20	47,60	20,00	24,00	18,50	44,5	46,1	40,0	5,00	4,00	79,0	92,5	6,77	PHC HB76.2F2...
HP80	80,00	50,00	20,00	24,00	18,50	44,5	46,1	40,0	5,00	4,00	79,0	92,5	6,81	PHC HP80...
HP100	100,00	45,00	22,00	16,00	12,00	46,0	47,5	35,0	5,00	5,00	75,0	90,0	6,20	PHC HP100...
HP100F1	100,00	45,00	22,00	18,00	12,00	47,2	48,5	35,0	5,00	5,00	75,0	90,0	6,15	PHC HP100F1...
HP101.6	101,60	47,60	19,00	19,00	13,20	46,2	48,0	40,0	5,00	4,00	53,0	58,2	6,09	PHC HP101.6...
HP101.6F2	101,60	66,70	25,40	26,90	20,10	59,2	60,7	51,0	7,10	5,10	150,0	160,0	14,23	PHC HP101.6F2...
HP152	152,40	66,70	25,40	26,90	19,56	57,2	59,5	50,8	7,10	5,10	94,0	107,8	9,90	PHC HP152...
HP152.4	152,40	47,60	19,00	19,00	13,20	46,2	48,0	40,0	5,00	4,00	54,0	59,5	5,00	PHC HP152.4...

Standard lengths are 10 ft and 5 m. To complete designation add chain length. For example, to order C2042HP in 10 ft length, use designation PHC C2042HPX10FT.

## Hollow pin series

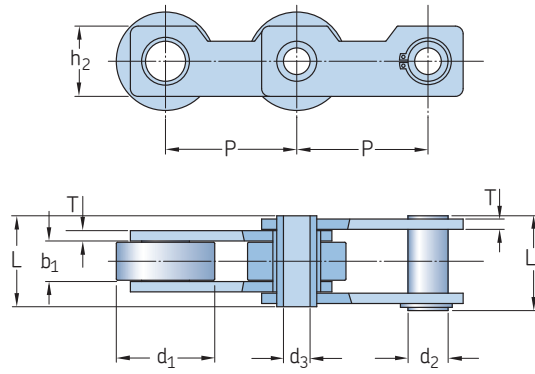

Chain number	Dimensions		Width between inner plates $b_1$ Min.	Pin diameter		Pin length		Plate height	Plate thickness	Ultimate tensile strength Q Min.	Average tensile strength $Q_0$	Mass per meter $q$	Designation
	Pitch P	Roller diameter $d_1$ Max.		$d_2$ Max.	$d_3$ Max.	L Max.	$L_c$ Max.	$h_2$ Max.	T				
-	mm									kN		Kg/m	-
<b>HB50.8SA1</b>	50,800	38,10	15,70	15,50	10,30	35,2	36,7	27,2	4,0	55,46	58,8	4,97	<b>PHC HB50.8SA1...</b>
<b>C2122HPF1</b>	76,200	47,60	29,00	17,81	12,70	43,3	44,7	38,1	4,8	53,34	59,2	7,05	<b>PHC C2122HPF1...</b>

Standard lengths are 10 ft and 5 m. To complete designation add chain length. For example, to order HB50.8SA1 in 10 ft length, use designation PHC HB50.8SA1X10FT.

## Engineering bush series

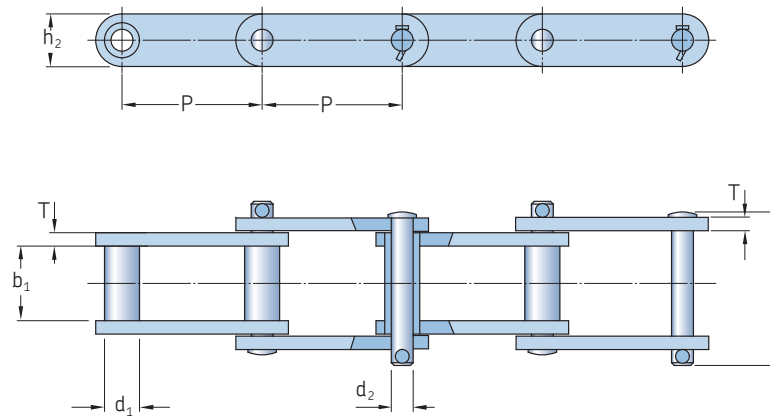

Chain number	Dimensions		Width between inner plates $b_1$ Min.	Pin diameter $d_2$ Max.	Pin length L Max.	Plate height $h_2$ Max.	Plate thickness T	Ultimate tensile strength Q Min.	Average tensile strength $Q_a$	Mass per meter q	Designation
	Pitch P	Roller diameter $d_1$ Max.									
-	mm							kN		Kg/m	-
<b>S188</b>	66,27	22,40	26,90	12,70	68,6	28,40	6,4	102,0	112,2	5,60	PHC S188...
<b>S131</b>	78,11	32,00	33,50	15,88	90,5	38,10	9,7	160,0	176,0	11,60	PHC S131...
<b>S102B</b>	101,60	25,40	54,10	15,88	111,3	38,10	9,7	160,0	176,0	10,40	PHC S102B...
<b>S102.5</b>	102,36	34,93	57,15	19,05	115,0	44,45	9,5	214,0	235,4	14,09	PHC S102.5...
<b>S111</b>	120,90	36,60	66,80	19,05	131,2	50,80	9,7	214,0	235,4	15,90	PHC S111...
<b>S111F1</b>	120,90	36,51	66,68	19,05	125,0	50,80	9,5	214,0	235,4	15,46	PHC S111F1...
<b>S110</b>	152,40	32,00	54,10	15,88	111,3	38,10	9,7	160,0	176,0	9,80	PHC S110...
<b>S856</b>	152,40	44,40	76,20	25,40	154,9	63,50	12,7	365,0	401,5	25,00	PHC S856...
<b>S857</b>	152,40	44,40	76,20	25,40	154,9	82,60	12,7	432,0	475,2	32,00	PHC S857...
<b>S859</b>	152,40	60,40	95,30	31,75	188,5	101,60	16,0	690,0	759,0	55,90	PHC S859...
<b>S110F1</b>	152,40	31,75	53,48	15,88	111,0	44,45	9,5	160,0	176,0	10,50	PHC S110F1...
<b>S150</b>	153,67	44,70	84,30	25,40	164,6	63,50	12,7	378,0	416,0	25,70	PHC S150...
<b>S864</b>	177,80	60,40	95,30	31,75	188,5	101,60	16,0	690,0	759,0	51,80	PHC S864...

Standard lengths are 10 ft and 5 m. To complete designation add chain length. For example, to order S102B in 10 ft length, use designation PHC S102BX10FT.

## Engineering bush series attachments

A-1, K-1 attachment | A-2, K-2 attachment

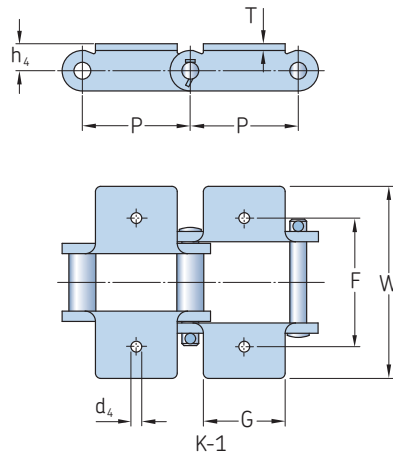
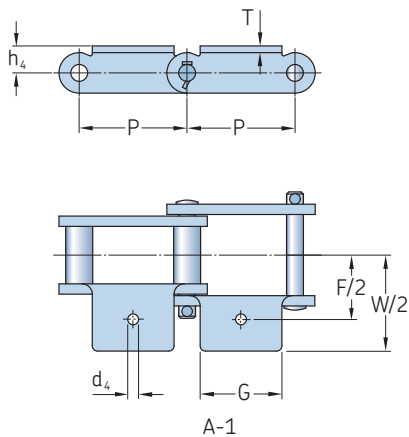

Chain number	Dimensions								Designation
	Pitch								
	P	G	F	W	h <sub>4</sub>	d <sub>4</sub>	T		
-	mm								-
S102B	101,60	77,0	121,0	180,8	25,4	10,2	9,7	PHC S102B...	
S131	78,11	73,9	104,6	157,0	25,4	13,5	9,7	PHC S131...	
S188	66,27	54,6	95,2	131,6	20,6	10,2	6,4	PHC S188...	

To complete designation add attachment spacing and type followed by chain length. For example PHC S102B-L2A1X10FT (S102B chain with A-1 attachment on every second link, 10 feet chain length).

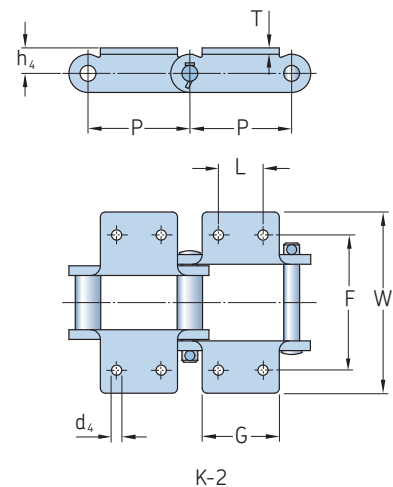
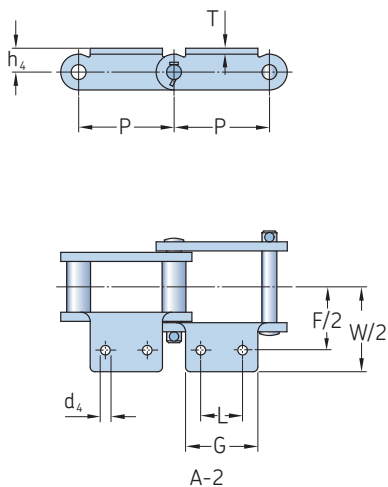

Chain number	Dimensions								Designation
	Pitch								
	P	L	G Max.	F	W Max.	h <sub>4</sub>	d <sub>4</sub> Min.	T	
-	mm								-
S102B	101,60	44,50	69,90	134,90	180,80	25,40	10,20	9,70	PHC S102B...
S110	152,40	44,50	89,60	134,90	180,80	25,40	10,20	9,70	PHC S110...
S111	120,90	58,70	92,70	158,80	210,80	38,10	13,50	9,70	PHC S111...
S131	78,11	38,10	73,90	104,60	157,00	25,40	13,50	9,70	PHC S131...
S150	153,67	69,90	108,70	190,50	249,40	47,80	13,50	12,70	PHC S150...
S188	66,27	31,80	54,60	106,40	131,60	20,60	8,60	6,40	PHC S188...
S856	152,40	63,50	103,10	184,20	241,30	47,80	16,80	12,70	PHC S856...
S102.5	102,36	44,45	69,00	136,53	163,51	28,58	9,50	9,50	PHC S102.5...
S110F1	152,40	44,45	88,90	134,94	165,10	27,78	10,30	9,50	PHC S110F1...
S111F1	120,90	58,70	87,50	158,75	196,85	38,10	13,70	9,50	PHC S111F1...

To complete designation add attachment spacing and type followed by chain length. For example PHC S102B-L2A2X10FT (S102B chain with A-2 attachment on every second link, 10 feet chain length).

## Engineering bush series attachments

### A-22 attachment | K-3 attachment

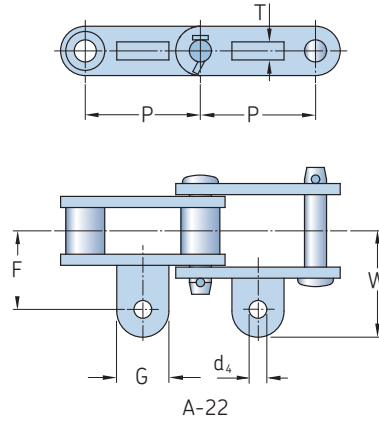

Chain number	Dimensions							Designation
	Pitch							
	P	G	F	W	d <sub>4</sub>	T		
-	mm							-
S188	66,27	49,2	45,2	61,2	10,2	10,4	PHC S188...	

To complete designation add attachment spacing and type followed by chain length. For example PHC S188-L2A22X10FT (S188 chain with A-22 attachment on every second link, 10 feet chain length).

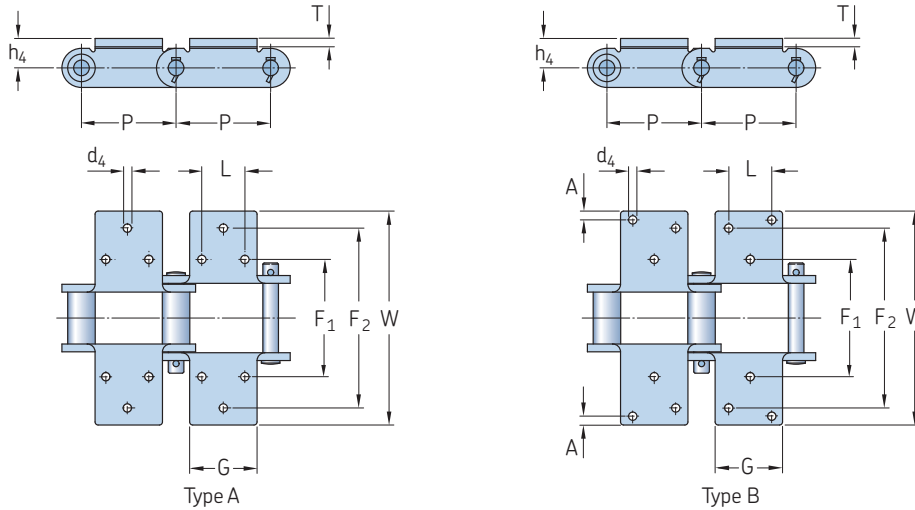

Type	Chain number	Dimensions									Designation
		Pitch									
		P	G	L	F <sub>1</sub>	F <sub>2</sub>	W	h <sub>4</sub>	d <sub>4</sub>	T	
-		mm									-
A	S150	153,67	109,5	69,9	190,5	292,1	347,5	47,8	13,5	13,5	PHC S150...
B	S856	152,40	152,4	69,9	166,6	277,9	349,3	47,8	13,5	13,5	PHC S856...

To complete designation add attachment spacing and type followed by chain length. For example PHC S150-L2K3X10FT (S150 chain with K-3 attachment on every second link, 10 feet chain length).



## Engineering bush series attachments

K-35 attachment | K-44 attachment

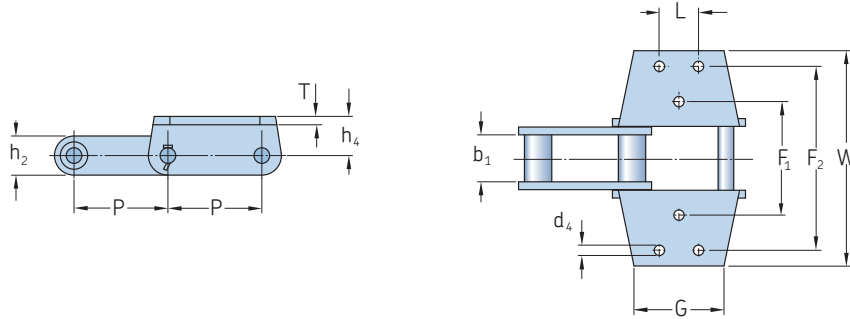

K-35

Chain number	Dimensions										Designation	
	Pitch	P	G	L	F <sub>1</sub>	F <sub>2</sub>	W	h <sub>4</sub>	d <sub>4</sub>	T		
-	mm											-
S856	152,40	146,1	63,5	184,2	298,5	349,3	47,8	16,8	13,5			PHC S856...

To complete designation add attachment spacing and type followed by chain length. For example PHC S856-L2K35X10FT (S856 chain with K-35 attachment on every second link, 10 feet chain length).

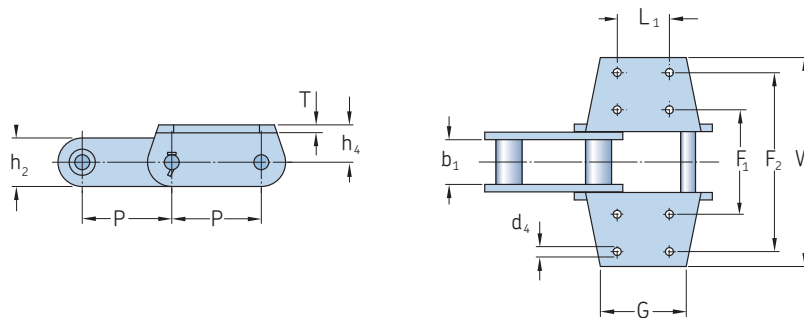

K-44

Chain number	Dimensions										Designation	
	Pitch	P	G	L <sub>1</sub>	L <sub>2</sub>	F <sub>1</sub>	F <sub>2</sub>	W	h <sub>4</sub>	d <sub>4</sub>		T
-	mm											-
S857	152,40	146,1	88,9	88,9	177,8	304,8	355,6	63,5	13,5	13,5		PHC S857...
S859	152,40	146,1	114,3	69,9	228,6	330,2	381,0	76,2	16,8	13,5		PHC S859...
S864	177,80	146,1	139,7	95,3	228,6	330,2	381,0	76,2	16,8	13,5		PHC S864...

To complete designation add attachment spacing and type followed by chain length. For example PHC S857-L2K44X10FT (S857 chain with K-44 attachment on every second link, 10 feet chain length).

## Combination series

Cottered

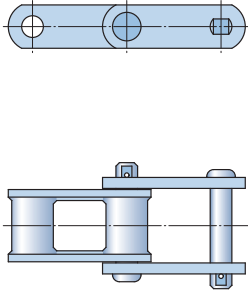

Riveted

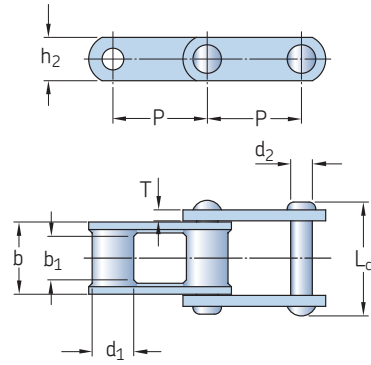

C Type combination chain

Cottered

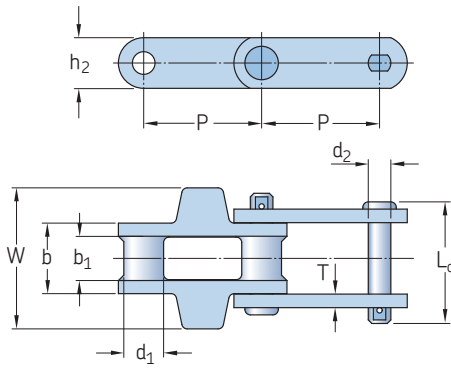

Riveted

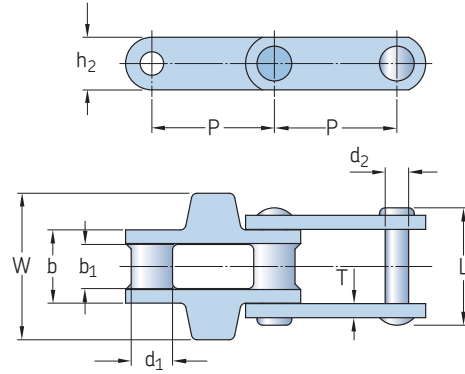

BRH Type combination chain

Cottered

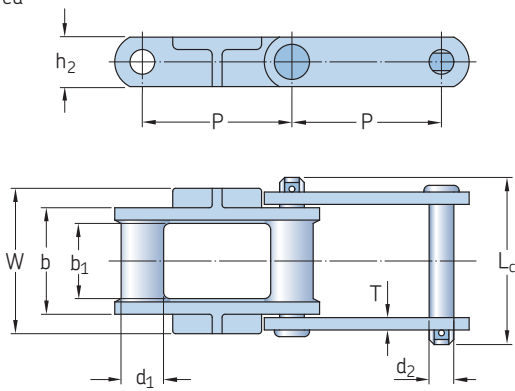

Riveted

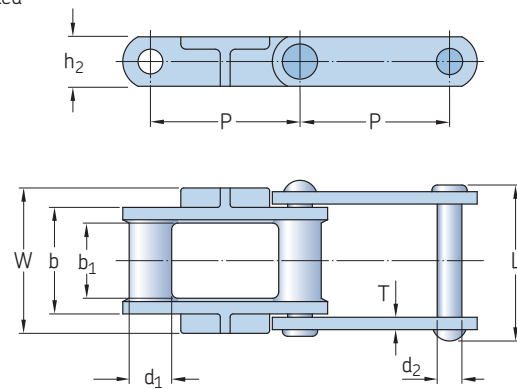

MBP Type combination chain

## Combination series

Cottered

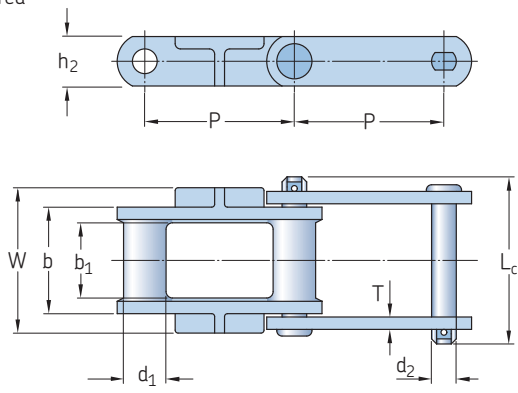

Riveted

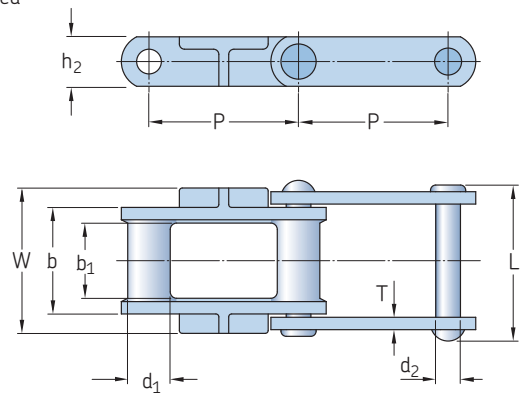

PW Type combination chain

Chain number	Dimensions		Sprocket face width $b_1$	Inner block width $b$	Pin diameter $d_2$	Plate height $h_2$	Plate thickness $T$	Pin length $L$	Barrel diameter $d_1$	Designation
	Pitch $P$									
-	mm	in.	mm							-
C55	41,43	1,631	17,50	32,00	9,50	19,00	4,80	50,00	18,30	PHC C55...
C55L	41,43	1,631	17,50	32,00	10,00	19,00	4,80	50,00	18,30	PHC C55L...
C60	58,60	2,307	22,35	42,92	12,70	19,05	6,35	73,15	19,05	PHC C60...
C77	58,62	2,308	17,50	32,00	11,10	22,00	4,80	57,15	18,30	PHC C77...
C188	66,27	2,609	23,80	39,60	12,70	29,00	5,80	63,50	22,35	PHC C188...
C131	78,11	3,075	28,50	52,00	16,00	38,00	9,00	88,90	31,00	PHC C131...
C102B	101,60	4,000	50,80	73,00	16,00	38,00	9,00	111,25	24,64	PHC C102B...
C1021/2	102,62	4,040	50,80	73,91	19,05	35,05	9,65	111,25	35,00	PHC C1021/2...
C111C	103,53	4,760	60,45	86,00	19,05	36,58	9,65	127,00	36,58	PHC C111C...
C111	120,90	4,760	60,00	86,00	19,00	44,00	9,00	127,00	36,58	PHC C111...
C110	152,40	6,000	49,28	73,15	15,88	31,75	9,65	111,25	31,75	PHC C110...
C132	152,40	6,000	73,00	111,00	25,40	50,80	12,00	165,10	43,70	PHC C132...
C133	152,40	6,000	31,75	73,15	22,23	44,45	9,65	101,60	44,45	PHC C133...
MBP132	153,67	6,050	79,25	109,50	25,40	43,69	12,70	165,10	43,70	PHC MBP132...
MBP132C	153,67	6,050	79,25	109,50	25,40	43,69	12,70	165,10	43,70	PHC MBP132C...
PW132	153,67	6,050	79,25	109,50	25,40	43,69	12,70	165,10	43,70	PHC PW132...
BRH188	66,27	2,609	23,80	39,60	14,30	28,50	5,80	63,50	22,35	PHC BRH188...
C188L	66,27	2,609	23,80	39,60	14,30	29,00	5,80	63,50	22,35	PHC C188L...

Standard lengths are 10 ft and 5 m. To complete designation add chain length. For example, to order C55 in 10 ft length, use designation PHC C55X10FT.

**Combination series attachments**  
A-22 Attachment | K-2 Attachment

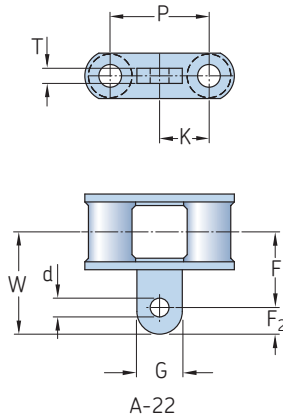

Chain number	Dimensions		Bolt diameter	Hole diameter	W	F <sub>2</sub>	K	F	G	T	Designation
	Pitch	P									
	mm	in.	mm								
C55	41,43	1,631	7,87	8,64	49,28	11,18	20,57	38,10	19,05	6,35	PHC C55...
C188	66,27	2,609	9,65	10,41	47,75	11,18	33,27	36,58	22,35	9,65	PHC C188...

To complete designation add attachment spacing and type followed by chain length. For example PHC C55-L2A22X10FT (C55 chain with A22 attachment on every second link, 10 feet chain length).

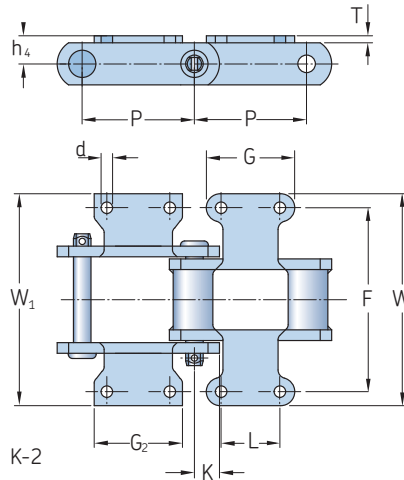

Chain number	Dimensions		Bolt diameter	Hole diameter	h <sub>4</sub>	K	F	L	G	G <sub>2</sub>	T	T <sub>1</sub>	W	W <sub>1</sub>	Designation
	Pitch	P													
	mm	in.	mm												
C102B	101,60	4,000	9,65	10,41	25,40	50,80	134,87	44,45	71,37	66,55	5,59	9,65	160,27	171,45	PHC C102B...
C102 1/2	102,62	4,040	9,65	11,18	25,40	51,31	134,87	44,45	71,37	73,15	7,87	9,65	165,10	165,10	PHC C102 1/2...
C110	152,40	6,000	9,65	10,41	25,40	76,20	134,87	44,45	73,15	73,15	7,87	9,65	169,93	171,45	PHC C110...
C111	120,90	4,760	12,70	14,22	28,45	60,45	158,75	58,67	88,90	90,42	7,87	9,65	190,50	195,33	PHC C111...
C111C	120,90	4,760	12,70	14,22	28,45	60,45	158,75	58,67	88,90	90,42	7,87	9,65	190,50	195,33	PHC C111C...
C131	78,11	3,075	12,70	14,22	25,40	38,86	104,65	38,10	66,55	63,50	7,87	9,65	133,35	136,65	PHC C131...
C132	153,67	6,050	12,70	14,22	31,75	76,96	190,50	69,85	101,60	101,60	12,70	12,70	228,60	244,35	PHC C132...

To complete designation add attachment spacing and type followed by chain length. For example PHC C102B-L2K2X10FT (C102B chain with K2 attachment on every second link, 10 feet chain length).

## Combination series attachments

### S-1 attachments

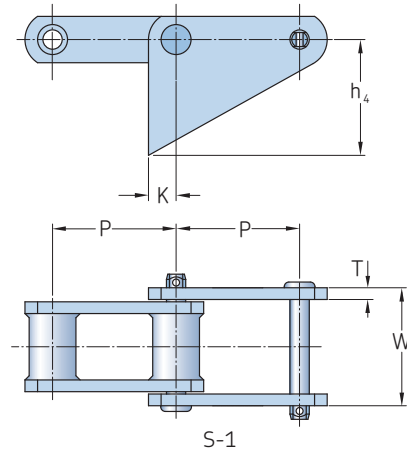

Chain number	Dimensions		h <sub>4</sub>	K	P	T	W	Designation
	Pitch							
	P	P						
-	mm	in.	mm					-
<b>C102 1/2</b>	102,62	4,040	95,25	25,40	73,15	9,65	94,49	PHC C102 1/2...
<b>C111</b>	120,90	4,760	111,25	25,40	88,90	9,65	106,43	PHC C111...
<b>C111C</b>	120,90	4,760	111,25	25,40	88,90	9,65	106,43	PHC C111C...
<b>C132</b>	153,67	6,050	127,00	32,51	101,60	12,70	138,18	PHC C132...
<b>PW132</b>	153,67	6,050	127,00	32,51	101,60	12,70	138,18	PHC PW132...
<b>MBP132</b>	153,67	6,050	127,00	32,51	101,60	12,70	138,18	PHC MBP132...
<b>MBP132C</b>	153,67	6,050	127,00	32,51	101,60	12,70	138,18	PHC MBP132C...
<b>C188</b>	66,27	2,609	66,55	15,75	55,63	6,35	53,85	PHC C188...

To complete designation add attachment spacing and type followed by chain length. For example PHC C111-L2S1X10FT (C111 chain with S1 attachment on every second link, 10 feet chain length).

## H class mill series

Cottered

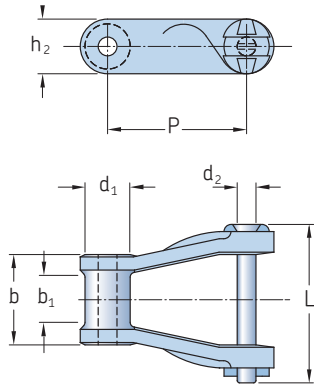

Riveted

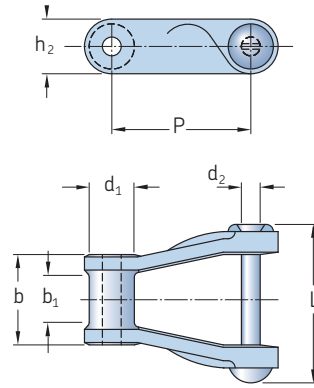

Chain number	Dimensions		Pin diameter	Inner block width	Sprocket face width	Plate height	Barrel Diameter	Pin Length	Designation
	Pitch								
	P		d <sub>2</sub>	b	b <sub>1</sub>	h <sub>2</sub>	d <sub>1</sub>	L	
	in.	mm							
H60	2,308	58,62	8,00	38,00	19,00	19,00	19,05	66,55	PHC H60...
H62	1,654	42,01	7,92	38,10	22,23	19,05	22,35	73,15	PHC H62...
H74	2,609	66,27	9,53	42,16	25,40	25,40	22,35	73,15	PHC H74...
H75	2,609	66,27	7,92	42,16	25,40	19,05	22,35	81,00	PHC H75...
H78	2,609	66,27	12,70	76,70	28,50	28,50	22,35	81,00	PHC H78...
H79	2,609	66,27	12,70	47,75	28,45	28,45	31,00	98,50	PHC H79...
H82	3,075	78,11	14,00	55,00	32,00	32,00	35,00	106,43	PHC H82...
H87	4,000	101,60	15,88	60,45	38,10	35,05	36,60	121,00	PHC H87...
H124	4,000	101,60	19,05	69,85	41,15	39,62			PHC H124...

Standard lengths are 10 ft and 5 m. To complete designation add chain length. For example, to order H60 in 10 ft length, use designation PHC H60X10FT.

## H class mill series attachments

### A-1 Attachment | K-1 Attachment

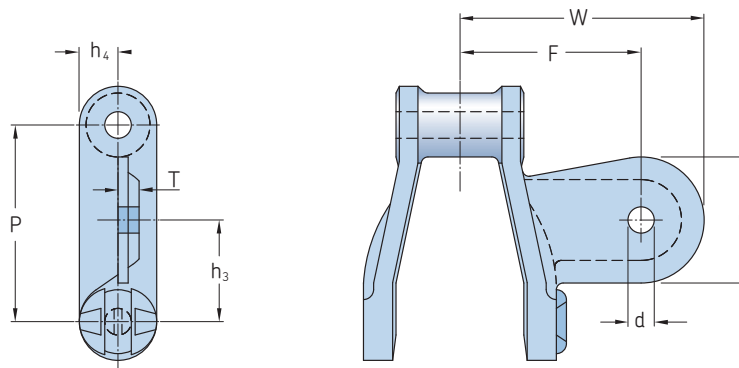

A-1

Chain number	Dimensions		Bolt diameter	Hole diameter		W	F	G	T	Designation	
	Pitch	P		d	h <sub>4</sub>						h <sub>3</sub>
-	mm	in.	mm							-	
H78-L	66,27	2,609	9,65	10,41	14,22	33,27	76,20	55,63	41,15	7,87	PHC H78-L...
H78-R	66,27	2,609	9,65	10,41	14,22	33,27	76,20	55,63	41,15	7,87	PHC H78-R...

To complete designation add attachment spacing and type followed by chain length. For example PHC H78-L2A1-RX10FT (H78 chain with A1-R attachment on every second link, 10 feet chain length).

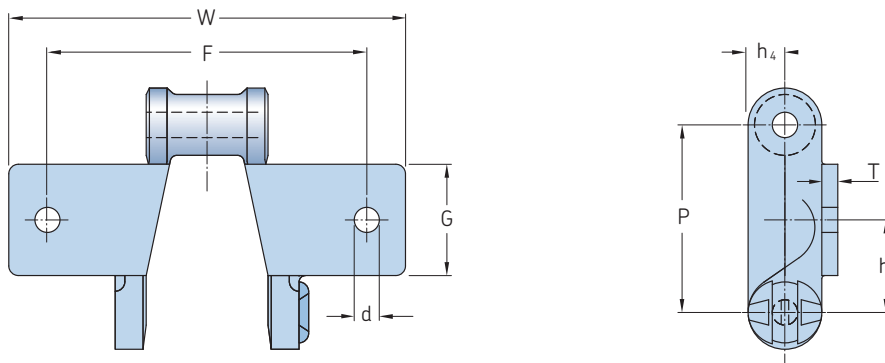

K-1

Chain number	Dimensions		Bolt diameter	Hole diameter		F	G	T	W	Designation	
	Pitch	P		d	h <sub>4</sub>						h <sub>3</sub>
-	mm	in.	mm							-	
H60	58,62	2,308	7,87	8,64	19,05	26,92	76,20	28,45	4,83	101,60	PHC H60...
H78	66,27	2,609	9,65	10,41	20,57	31,75	101,60	35,05	5,59	127,00	PHC H78...

To complete designation add attachment spacing and type followed by chain length. For example PHC H60-L2K1X10FT (H60 chain with K1 attachment on every second link, 10 feet chain length).

# Rivetless series

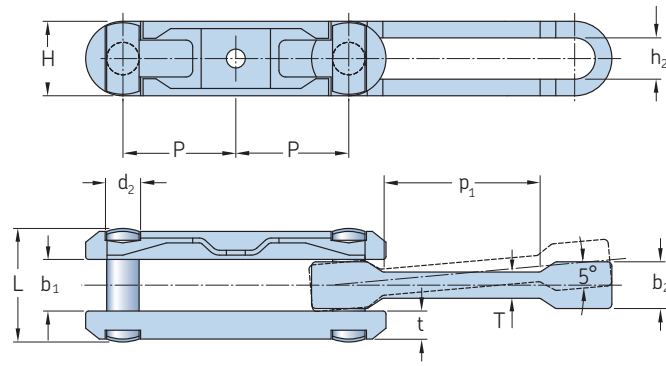

Chain number	Dimensions		Pin length L	Center link gap h <sub>2</sub> Min.	Chain height H Max.	Plate thickness		Center link width b <sub>1</sub>	Ultimate tensile strength Q Min. kN	Designation
	Pitch P	Pin diameter d <sub>2</sub>				t	T			
-										
mm										
X228	50,80	6,40	27,70	7,90	18,00	6,40	9,40	13,00	26,70	PHC X228...
X348	76,20	12,40	43,90	13,50	27,90	10,20	13,00	20,10	97,90	PHC X348...
X458	101,60	16,00	57,20	16,80	36,60	12,20	16,30	27,20	210,00	PHC X458...
X458XP*	101,60	16,00	57,20	16,80	36,60	12,20	16,30	27,20	255,00	PHC 468...
468	102,40	19,05	84,10	22,35	47,80	10,40	28,70	42,93	391,00	PHC 468H...
X678	152,40	22,10	77,00	24,10	51,60	17,80	21,10	34,30	380,00	PHC X658...
X678XP*	152,40	22,10	77,00	24,10	51,60	17,80	21,10	34,30	450,00	PHC X678...
698	152,40	28,70	95,25	31,75	65,00	14,20	25,40	41,40	650,00	PHC 678...
698XP*	152,40	28,70	95,25	31,75	65,00	14,20	25,40	41,40	720,00	PHC 698...
998	229,40	28,70	95,30	31,75	67,60	14,20	25,40	42,93	578,00	PHC XT100...
9118	229,40	35,00	124,00	38,10	76,20	19,80	33,30	51,10	979,00	PHC XT160...

Standard lengths are 10 ft and 5 m. To complete designation add chain length. For example, to order X228 in 10 ft length, use designation PHC X228X10FT.  
 \* Please, note that XP stands for Xtra Strength.



## Barloop series

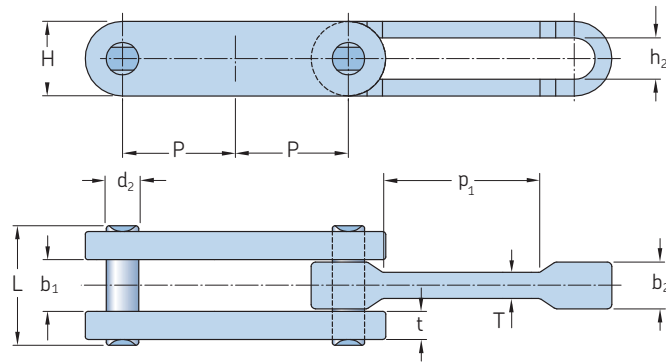

Chain number	Dimensions		Pin length L	Center link width b <sub>1</sub>	Chain link height H	Link thickness T	Center link gap h <sub>2</sub>	Rated working load	Mass per meter	Designation
	Pitch P	Pin diameter d <sub>2</sub>								
–	mm							kN	Kg/m	–
<b>S348</b>	76,68	12,70	44,45	20,57	28,70	12,70	14,22	8,89	3,58	PHC S348...
<b>S458</b>	102,39	16,00	52,32	26,92	35,05	16,00	17,53	17,78	5,22	PHC S458...
<b>S468</b>	102,39	19,05	74,68	42,93	50,80	28,70	22,35	29,78	11,78	PHC S468...
<b>S678</b>	153,19	22,35	76,20	36,58	50,80	20,57	25,40	34,22	12,83	PHC S678...
<b>S698</b>	153,19	28,70	82,55	41,40	63,50	25,40	31,75	48,00	17,45	PHC S698...
<b>S998</b>	229,39	28,70	82,55	42,93	63,50	25,40	31,75	48,00	18,05	PHC S998...
<b>S9118</b>	229,39	35,05	111,25	54,10	76,20	33,27	38,10	81,33	34,75	PHC S9118...

Standard lengths are 10 ft and 5 m. To complete designation add chain length. For example, to order S348 in 10 ft length, use designation PHC S348X10FT.

900 class pintle series

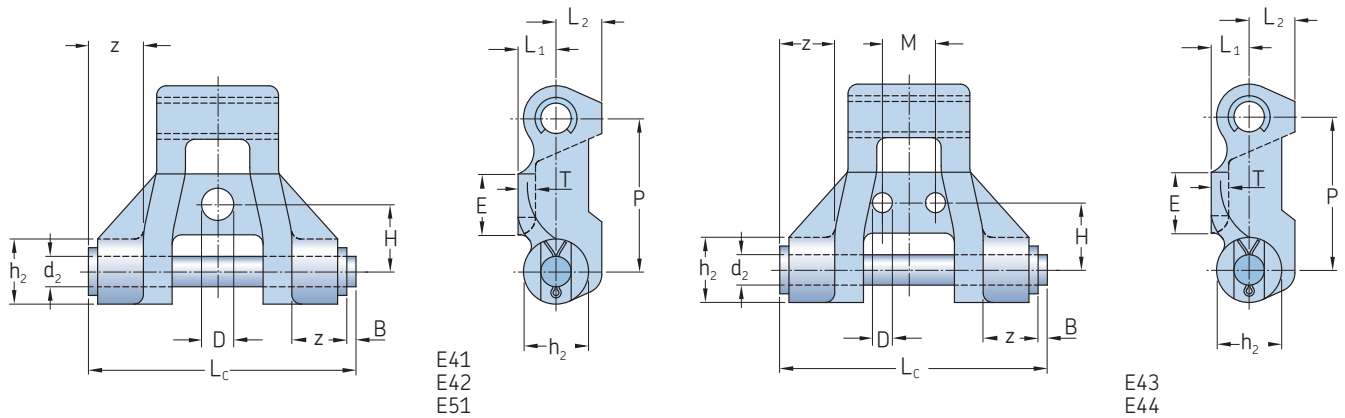

Chain number	Dimensions														Mass	Designation	
	Pitch		d <sub>2</sub>	B	L <sub>c</sub>	D	E	h <sub>2</sub>	L <sub>1</sub>	H	C	Z	L <sub>2</sub>	T			
-	in.	mm														Kg/m	-
902E41	2,970	75,4	15,88	4,8	139,7	16,8	31,8	34,0	22,4	35,1	-	28,7	23,9	9,1	18,2	PHC 902E41...	
902E42	2,970	75,4	15,88	4,8	139,7	16,8	31,8	34,0	22,4	37,6	-	28,7	23,9	9,1	18,2	PHC 902E42...	
902E43	2,970	75,4	15,88	4,8	139,7	10,4	31,8	34,0	22,4	35,1	27,7	28,7	23,9	9,1	18,2	PHC 902E43...	
902E44	2,970	75,4	15,88	4,8	139,7	10,4	31,8	34,0	22,4	37,6	27,7	28,7	23,9	9,1	18,2	PHC 902E44...	
901E41	3,149	80,0	15,88	4,8	139,7	16,8	31,8	34,0	19,8	35,1	-	28,7	23,9	9,1	17,8	PHC 901E41...	
901E42	3,149	80,0	15,88	4,8	139,7	16,8	31,8	34,0	19,8	40,1	-	28,7	23,9	9,1	17,8	PHC 901E42...	
901E43	3,149	80,0	15,88	4,8	139,7	10,4	31,8	34,0	19,8	35,1	27,7	28,7	23,9	9,1	17,8	PHC 901E43...	
901E44	3,149	80,0	15,88	4,8	139,7	10,4	31,8	34,0	19,8	40,1	27,7	28,7	23,9	9,1	17,8	PHC 901E44...	
907E51	3,170	80,5	15,88	4,8	139,7	16,8	33,3	36,6	18,3	42,9	-	28,7	23,9	9,1	17,6	PHC 907E51...	

Standard lengths are 10 ft and 5 m. To complete designation add chain length. For example, to order 901E41 in 10 ft length, use designation PHC 901E41X10FT.

## 400 class pintle series - cast steel

Cottered

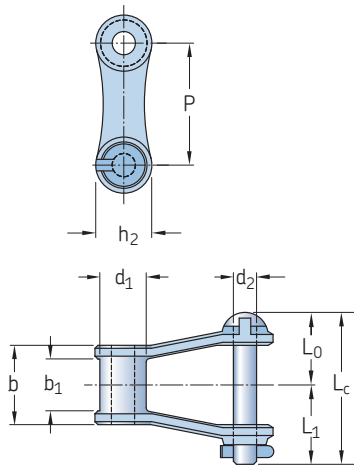

Riveted

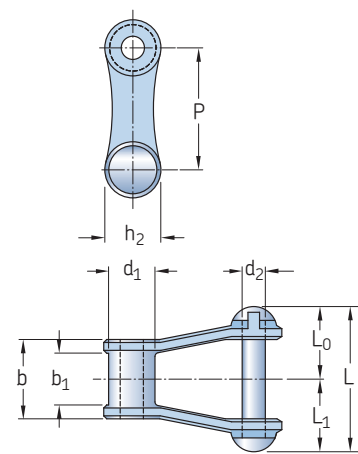

Chain number	Dimensions		Sprocket face width $b_1$	Overall width (cottered) $L_c$	Overall width (riveted) $L$	Pin diameter $d_2$	Height of sidebar $h_2$	Barrel diameter $d_1$	Head of pin to centre line $L_0$	End of pin to centre line (cottered) $L_1$	End of pin to centre line (riveted) $L_2$	Barrel length $b$	Average tensile strength kN	Designation
	Pitch $P$													
-	mm	in										mm	kN	-
442CS	34,93	1,375	15,748	51,562	47,75	7,87	19,05	14,22	24,64	26,92	23,11	26,92	34,7	PHC 442CS...
452CS	38,25	1,506	15,748	56,388	52,32	9,65	21,34	17,53	26,16	30,23	26,16	27,69	40,4	PHC 452CS...
445CS	41,40	1,630	17,526	51,562	47,75	7,87	19,05	15,75	24,64	26,92	23,11	26,92	34,7	PHC 445CS...
455CS	41,40	1,630	17,526	56,388	52,32	9,65	21,34	15,75	26,16	30,23	26,16	28,45	42,2	PHC 455CS...
462CS	41,50	1,634	22,352	65,024	60,45	11,18	23,88	18,29	31,75	33,27	28,45	36,58	52,0	PHC 462CS...
477CS	58,62	2,308	17,526	60,452	57,15	11,18	25,40	18,29	29,46	30,99	27,69	31,75	55,5	PHC 477CS...
488CS	66,27	2,609	23,876	74,676	69,85	11,18	23,88	22,35	36,58	38,10	33,27	41,15	63,6	PHC 488CS...
4103CS	78,11	3,075	28,448	90,424	82,55	19,05	38,10	31,75	44,45	45,97	38,10	47,75	94,5	PHC 4103CS...

Standard lengths are 10 ft and 5 m. To complete designation add chain length. For example, to order S102B in 10 ft length, use designation PHC S102BX10FT.

400 pintle series attachments - cast steel

F-2 attachment | K-1 attachment

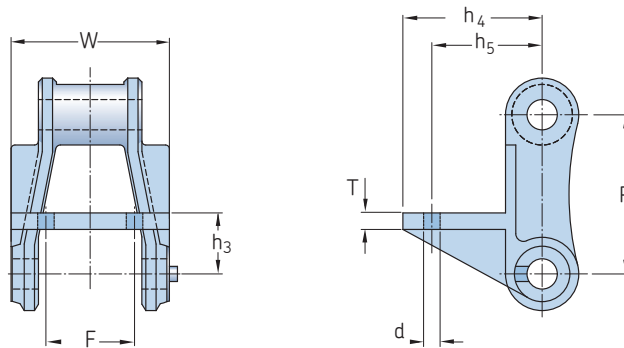

F-2

Chain number	Dimensions		Bolt diameter d	Hole diameter	h <sub>4</sub>	h <sub>3</sub>	F	h <sub>5</sub>	P	T	W	Designation
	Pitch P											
-	mm	in	mm									-
445CS	41,40	1,630	4,83	5,59	32,51	15,75	26,92	23,88	23,11	4,06	38,10	PHC 445CS...
455CS	41,40	1,630	4,83	5,59	31,75	15,75	26,92	23,88	20,57	4,06	45,97	PHC 455CS...
462CS	41,50	1,634	4,83	5,59	33,27	15,75	26,92	25,40	20,57	4,06	53,09	PHC 462CS...
477CS	58,62	2,308	7,87	8,64	50,80	19,05	44,45	36,58	38,10	6,35	66,55	PHC 477CS...
488CS	66,27	2,609	7,87	8,64	50,04	26,92	51,56	35,05	38,10	7,11	73,15	PHC 488CS...
4103CS	78,11	3,075	9,65	10,41	67,56	31,75	56,39	50,80	48,51	7,87	79,25	PHC 4103CS...

To complete designation add attachment spacing and type followed by chain length. For example PHC 445-L2F2X10FT (445 chain with F2 attachment on every second link, 10 feet chain length).

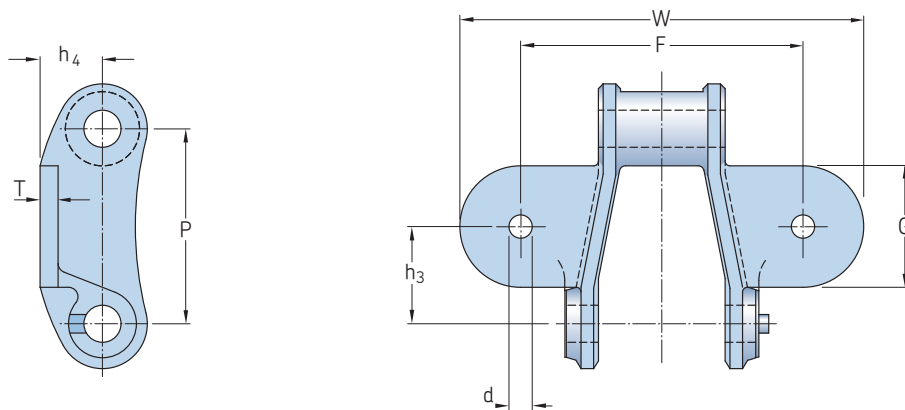

K-1

Chain number	Dimensions		Bolt diameter d	Hole diameter	h <sub>4</sub>	h <sub>3</sub>	F	G	T	W	Designation
	Pitch P										
-	mm	in	mm								-
452CS	38,25	1,506	4,83	5,59	11,18	19,05	52,32	18,29	4,06	69,85	PHC 452CS...
445CS	41,40	1,630	4,83	5,59	11,18	18,29	52,32	23,88	3,05	71,37	PHC 445CS...
455CS	41,40	1,630	6,35	7,11	11,18	20,57	50,80	20,57	4,06	73,15	PHC 455CS*...
462CS	41,50	1,634	6,35	7,11	12,70	20,57	60,45	23,88	4,06	82,55	PHC 462CS...
477CS	58,62	2,308	6,35	7,11	16,76	29,46	76,20	35,05	4,06	100,08	PHC 477CS...
488CS	66,27	2,609	7,87	8,64	16,76	33,27	96,77	35,05	4,83	120,65	PHC 488CS...

To complete designation add attachment spacing and type followed by chain length. For example PHC 445-L2K1X10FT (445 chain with K1 attachment on every second link, 10 feet chain length).

\* Available cottered construction only.

## 400 pintle series attachments - cast steel

### K-2 attachments

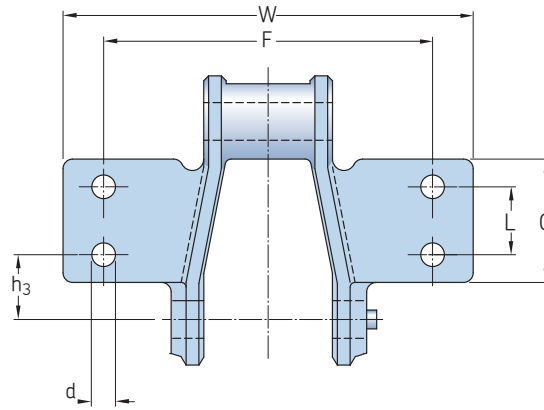
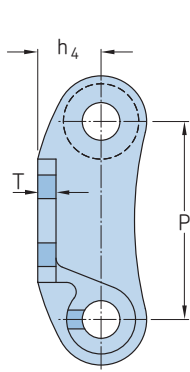

K-2

Chain number	Dimensions		Bolt diameter $d$	Hole diameter	$h_4$	$h_3$	$F$	$L$	$G$	$T$	$W$	Designation
	Pitch	P										
-	mm	in	mm	-	-	-	-	-	-	-	-	-
<b>477CS</b>	58,62	2,308	6,35	7,11	16,76	29,46	76,20	20,57	39,62	3,05	101,60	PHC 477CS...
<b>488CS</b>	66,27	2,609	7,87	8,64	16,76	32,51	91,95	31,75	53,85	4,83	114,30	PHC 488CS...
<b>4103CS</b>	78,11	3,075	12,70	14,22	21,34	38,86	104,65	38,10	66,55	7,87	133,35	PHC 4103CS...

To complete designation add attachment spacing and type followed by chain length. For example PHC 477-L2K2X10FT (477 chain with K2 attachment on every second link, 10 feet chain length).

## 700 class pintle series - cast steel

MS curved S/B

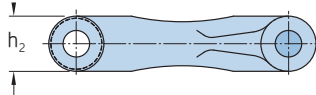

MS curved S/B

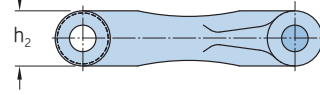

Plain straight S/B

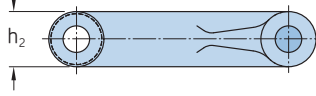

Plain straight S/B

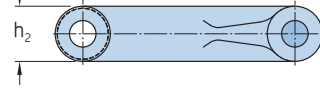

Riveted

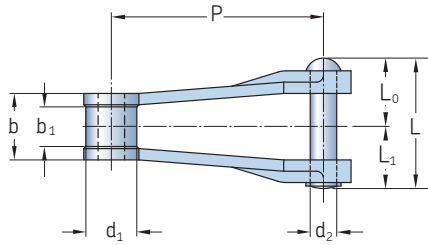

Cottered

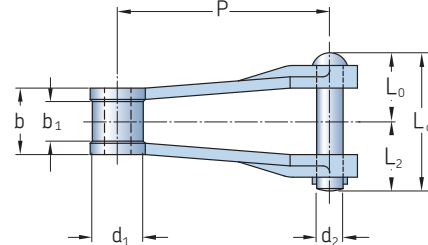

Chain number	Dimensions		Sprocket face width $b_1$	Barrel length $b$	Overall width (cottered) $L_c$	Overall width (riveted) $L$	Pin diameter $d_2$	Plate height $h_2$	Barrel diameter $d_1$	Head of pin to centre line $L_0$	End of pin to centre line (cottered) $L_2$	End of pin to centre line (riveted) $L_1$	Average tensile strength	Designation
	Pitch $P$													
	mm	in	mm										kN	
720CS	152,40	6,00	28,45	45,97	87,38	84,07	17,53	38,10	35,05	41,15	45,97	42,93	106,0	PHC 720CS...
720SCS	152,40	6,00	28,45	47,75	96,77	93,73	19,05	39,62	36,58	44,45	52,32	49,28	144,5	PHC 720SCS...
MS 720SCS	152,40	6,00	28,45	47,75	96,77	93,73	19,05	39,62	36,58	44,45	52,32	49,28	186,7	PHC MS 720SCS...
730CS	152,40	6,00	28,45	50,80	96,77	93,73	19,05	44,45	38,10	45,97	50,80	47,75	173,3	PHC 730CS...
MS 730SCS	152,40	6,00	28,45	50,80	96,77	93,73	19,05	44,45	38,10	45,97	50,80	47,75	173,3	PHC MS 730SCS...
788CS	66,27	2,61	23,88	41,15	84,07	81,03	14,22	30,23	22,35	39,62	44,45	41,15	101,1	PHC 788CS...

Standard lengths are 10 ft and 5 m. To complete designation add chain length. For example, to order 710 in 10 ft length, use designation PHC 710X10FT.

# 700 pintle series attachments - cast steel

A-2 attachments | F-2 attachments

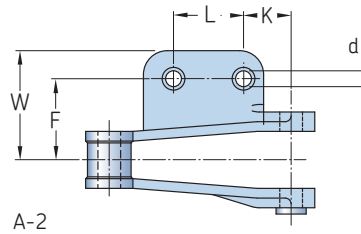
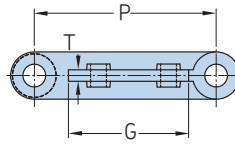

A-2

Chain number	Dimensions		Bolt diameter d	Hole diameter	W	K	L	F	G	T	Designation
	Pitch	P									
-	mm	in									-
720 CS	152,4	6,0	15,75	17,53	90,42	38,10	53,85	69,09	101,6	15,75	PHC 720CS...
MS 720S CS	152,4	6,0	15,75	17,53	90,42	49,28	53,85	69,85	95,25	15,75	PHC MS 720SCS...
730 CS	152,4	6,0	15,75	17,53	90,42	49,28	53,85	69,85	96,77	11,18	PHC 730CS...

To complete designation add attachment spacing and type followed by chain length. For example PHC 720-L2A2X10FT (720 chain with A2 attachment on every second link, 10 feet chain length).  
 Note: 730-A2 with bosses only.

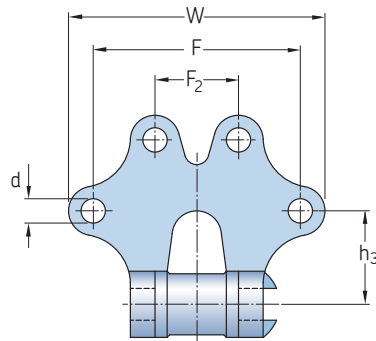

F-2

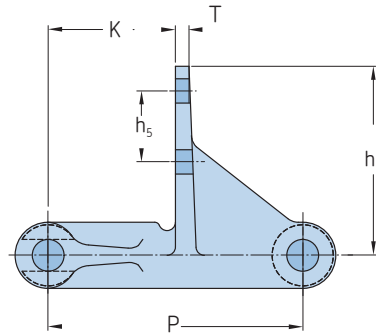

Chain number	Dimensions		Bolt diameter d	Hole diameter	W	K	F	F <sub>2</sub>	h <sub>3</sub>	h <sub>4</sub>	h <sub>5</sub>	T	Designation
	Pitch	P											
-	mm	in											-
720 CS	152,4	6,0	12,70	14,22	98,55	76,20	107,95	49,28	33,27	6,35	50,80	134,87	PHC 720CS...
720-S CS	152,4	6,0	11,18	11,18	98,55	76,20	107,95	49,28	33,27	6,35	50,80	134,87	PHC 720-SCS...
MS 720-S CS	152,4	6,0	11,18	11,18	98,55	76,20	107,95	49,28	33,27	6,35	50,80	134,87	PHC MS 720-SCS...
730 CS	152,4	6,0	11,18	11,18	97,54	76,20	107,95	49,28	33,27	9,65	50,80	134,87	PHC 730CS...
MS 730 CS	152,4	6,0	11,18	11,18	97,54	76,20	107,95	49,28	33,27	9,65	50,80	134,87	PHC MS 730CS...

To complete designation add attachment spacing and type followed by chain length. For example PHC 720-L2F2X10FT (720 chain with F2 attachment on every second link, 10 feet chain length).

## 700 pintle series attachments - cast steel

### M-1 attachments

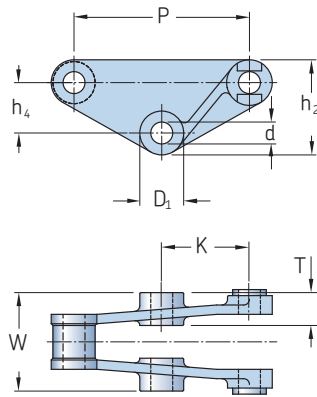

Chain number	Dimensions		Bolt diameter d	Hole diameter	D1	h <sub>4</sub>	K	h <sub>2</sub>	T	W	Designation
	Pitch	P									
	mm	in	mm								
720CS	152,40	6,000	19,05	20,57	38,10	38,10	76,20	76,20	19,05	76,20	PHC 720CS...
720SCS	152,40	6,000	19,05	20,57	38,10	38,10	76,20	76,20	19,05	76,20	PHC 720SCS...
MS 720SCS	152,40	6,000	19,05	20,57	38,10	38,10	76,20	76,20	19,05	76,20	PHC MS 720SCS...
730CS	152,40	6,000	19,05	20,57	38,10	41,15	76,20	82,55	19,05	76,20	PHC 730CS...
MS 730CS	152,40	6,000	19,05	20,57	38,10	41,15	76,20	82,55	19,05	76,20	PHC MS 730CS...

To complete designation add attachment spacing and type followed by chain length. For example PHC 720-L2M1X10FT (720 chain with M1 attachment on every second link, 10 feet chain length).



## Detachable series

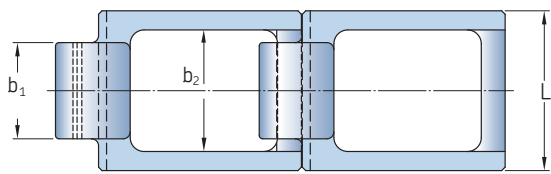
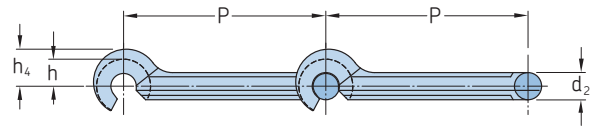
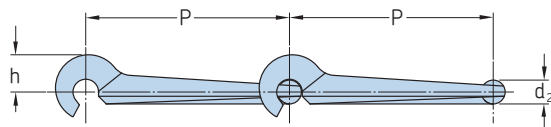

Type A

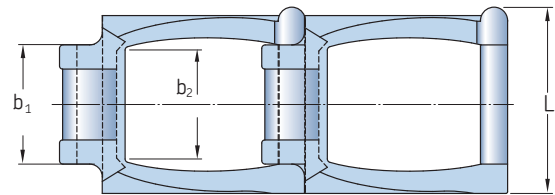

Type B

Chain number	Dimensions		Hook Style	Sprocket face width $b_2$	End bar diameter $d_2$	Backing $h$	Overall width $L$	Bearing length $b_1$	Rib depth $h_4$	Designation
	Pitch $P$									
–	mm	in	–	mm	–	–	–	–	–	–
25	22,91	0,902	A	9,65	3,56	5,08	19,81	10,41	–	PHC 25...
32	29,31	1,154	A	12,70	4,32	6,35	24,64	14,73	–	PHC 32...
42	34,93	1,375	A	15,75	5,59	7,11	32,51	19,56	–	PHC 42...
45	41,40	1,630	A	17,53	5,59	7,62	33,27	20,32	–	PHC 45...
51	29,34	1,155	A	14,22	6,86	9,14	31,75	17,02	–	PHC 51...
551	28,85	1,136	A	14,22	6,86	7,62	26,92	16,26	–	PHC 551...
52	38,25	1,506	A	15,75	6,86	8,64	38,86	21,08	–	PHC 52...
55	41,43	1,631	A	17,53	6,86	9,14	35,81	20,57	–	PHC 55...
57	58,62	2,308	A	19,05	6,86	10,41	45,97	27,69	–	PHC 57...
62	42,01	1,654	A	20,57	7,87	10,41	42,16	24,64	–	PHC 62...
S62	42,01	1,654	A	20,57	7,87	10,41	38,86	24,64	–	PHC S62...
67	58,62	2,308	B	17,53	7,87	10,41	51,56	34,54	13,46	PHC 67...
75	66,27	2,609	A	23,88	10,41	11,18	53,09	28,45	–	PHC 75...
77	58,34	2,297	B	17,53	9,91	9,14	56,39	36,07	15,49	PHC 77...
78	66,27	2,609	B	23,88	10,67	11,18	66,55	41,15	16,76	PHC 78...
88	66,27	2,609	B	23,88	12,19	11,18	69,85	45,21	19,81	PHC 88...
103	78,11	3,075	B	28,45	14,73	15,49	83,31	51,56	25,40	PHC 103...
124	103,20	4,063	B	31,75	19,56	17,27	103,12	58,42	33,27	PHC 124...

Standard lengths are 10 ft and 5 m. To complete designation add chain length. For example, to order 710 in 10 ft length, use designation PHC 710X10FT.

## Detachable series attachments

### A-1 attachments

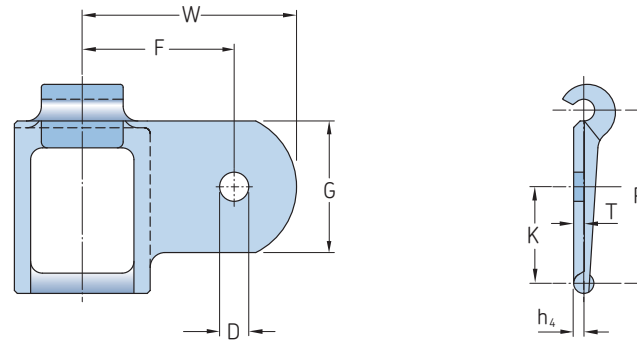

Right hand

Chain number	Dimensions		Bolt diameter	Hole diameter	W	h <sub>4</sub>	K	F	G	T	Designation
	Pitch	Pitch									
	P	P	D								
	mm	in	mm								
25A1-R	22,91	0,902	4,83	5,59	30,99	2,29	11,18	22,35	18,29	2,29	PHC 25A1-R...
25A1-L	22,91	0,902	4,83	5,59	30,99	2,29	11,18	22,35	18,29	2,29	PHC 25A1-L...
32A1-R	29,31	1,154	4,83	5,59	30,99	2,29	15,75	22,35	18,29	3,05	PHC 32A1-R...
32A1-L	29,31	1,154	4,83	5,59	30,99	2,29	15,75	22,35	18,29	3,05	PHC 32A1-L...
42A1-R	34,93	1,375	6,35	7,11	39,62	2,29	16,76	27,69	26,16	3,05	PHC 42A1-R...
42A1-L	34,93	1,375	6,35	7,11	39,62	2,29	16,76	27,69	26,16	3,05	PHC 42A1-L...
45A1-R	41,40	1,630	6,35	7,11	42,16	22,35	20,57	28,45	28,45	4,06	PHC 45A1-R...
45A1-L	41,40	1,630	6,35	7,11	42,16	22,35	20,57	28,45	28,45	4,06	PHC 45A1-L...
52A1-R	38,25	1,506	6,35	7,11	41,15	3,05	19,81	30,23	26,92	3,05	PHC 52A1-R...
52A1-L	38,25	1,506	6,35	7,11	41,15	3,05	19,81	30,23	26,92	3,05	PHC 52A1-L...
55A1-R	41,43	1,631	6,35	7,11	42,93	3,05	22,35	28,45	29,46	4,06	PHC 55A1-R...
55A1-L	41,43	1,631	6,35	7,11	42,93	3,05	22,35	28,45	29,46	4,06	PHC 55A1-L...
57A1-R	58,62	2,308	6,35	7,11	60,45	4,83	28,45	38,10	43,69	4,83	PHC 57A1-R...
57A1-L	58,62	2,308	6,35	7,11	60,45	4,83	28,45	38,10	43,69	4,83	PHC 57A1-L...
62A1-R	42,01	1,654	6,35	7,11	51,56	4,06	21,34	36,58	31,75	4,83	PHC 62A1-R...
62A1-L	42,01	1,654	6,35	7,11	51,56	4,06	21,34	36,58	31,75	4,83	PHC 62A1-L...
77A1-R	58,34	2,297	6,35	7,11	61,98	4,83	31,75	39,62	40,39	5,59	PHC 77A1-R...
77A1-L	58,34	2,297	6,35	7,11	61,98	4,83	31,75	39,62	40,39	5,59	PHC 77A1-L...

To complete designation add attachment spacing and type followed by chain length. For example PHC 25-L2A1-RX10FT (25 chain with A1-R attachment on every second link, 10 feet chain length). To determine the attachment type "left" or "right", view the chain link with the hook up and forward.

## Detachable series attachments

### K-1 attachments

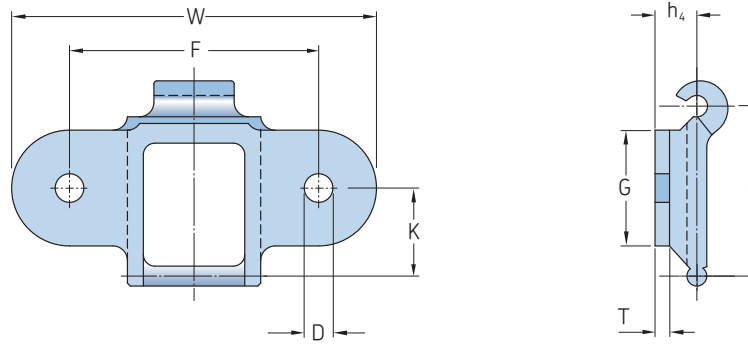

Chain number	Dimensions		Bolt diameter	Hole diameter	$h_4$	K	F	G	T	W	Designation
	Pitch										
	P		D								
	mm	in	mm								
32	29,31	1,154	4,83	5,59	9,65	14,99	44,45	14,99	2,29	58,67	PHC 32...
42	34,93	1,375	4,83	5,59	9,65	17,53	50,80	19,05	3,05	68,33	PHC 42...
45	41,40	1,63	4,83	5,59	10,41	19,81	50,80	21,34	3,05	68,33	PHC 45...
51	29,34	1,155	4,83	5,59	11,18	15,75	44,45	15,75	3,05	52,32	PHC 51...
52	38,25	1,506	4,83	5,59	11,18	18,29	60,45	22,35	3,05	71,37	PHC 52...
55	41,43	1,631	4,83	5,59	10,41	19,81	50,80	22,35	3,05	66,55	PHC 55...
62	42,01	1,654	6,35	7,11	11,94	21,34	60,45	23,88	4,06	84,07	PHC 62...
77	58,34	2,297	6,35	7,11	16,76	28,45	76,20	32,51	4,06	98,55	PHC 77...
78	66,27	2,609	6,35	7,11	15,75	31,75	85,85	35,05	4,06	97,54	PHC 78...
88	66,27	2,609	7,87	8,64	19,05	31,75	96,77	35,05	4,83	107,95	PHC 88...

To complete designation add attachment spacing and type followed by chain length. For example PHC 32-L2K1X10FT (32 chain with K1 attachment on every second link, 10 feet chain length).

## H class transfer (roof top) series

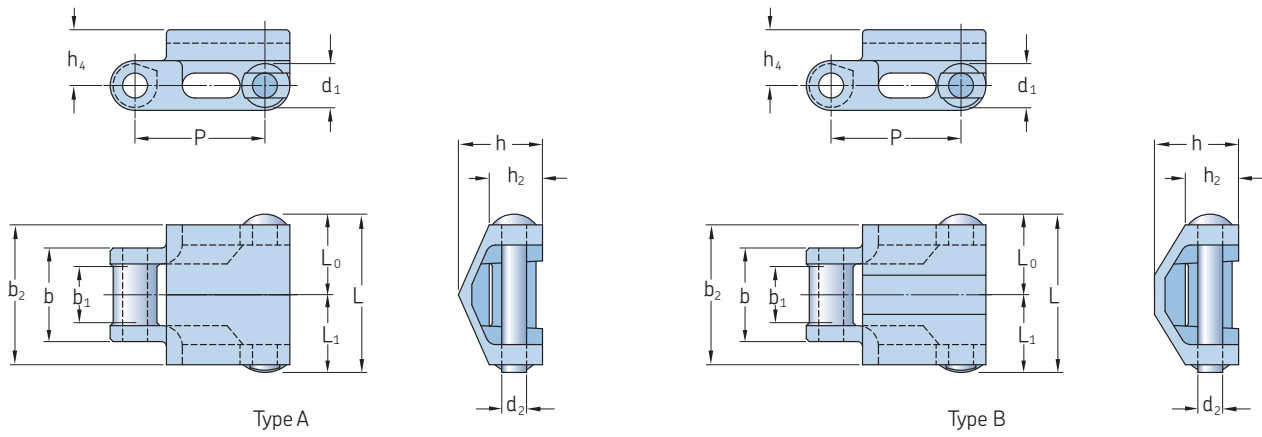

Chain number	Dimensions		Style of top A or B	Overall width (riveted) L	End of pin to centre line (riveted) $L_1$	Head of pin to centre line $L_0$	Barrel diameter $d_1$	Pin diameter $d_2$	Sprocket face width $b_1$	Overall barrel length b	Sidebar height $h_2$	Centre of pin to top height $h_4$	Overall height h	Width of top $b_2$	Average tensile strength	Designation
	Pitch P															
	mm	in		mm											kN	
H 78ACS	66,27	2,609	A	82,55	41,15	39,62	22,35	12,70	28,45	47,75	25,40	28,45	42,93	71,37	92,44	PHC H 78ACS...
H 78BCS	66,27	2,609	B	82,55	41,15	39,62	22,35	12,70	28,45	47,75	25,40	28,45	42,93	71,37	92,44	PHC H 78BCS...
H 130CS	101,60	4,000	A	82,55	41,15	41,15	25,40	12,70	25,40	41,15	26,92	29,46	42,93	71,37	80,89	PHC H 130CS...
H 131CS	101,60	4,000	A	101,60	52,32	49,28	31,75	15,88	41,15	63,50	39,62	37,34	57,15	87,38	132,89	PHC H 131CS...
H 138CS	101,60	4,000	B	82,55	41,15	41,15	25,40	12,70	25,40	41,15	26,92	29,46	42,93	71,37	86,67	PHC H 138CS...

Standard lengths are 10 ft and 5 m. To complete designation add chain length. For example, to order H78A in 10 ft length, use designation PHC H78AX10FT.

## Combination transfer (roof top) series

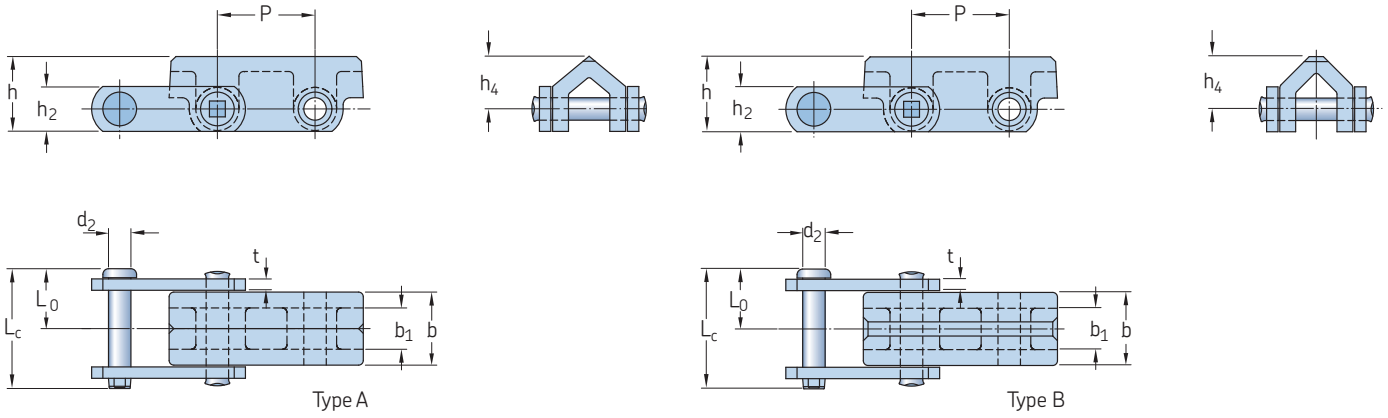

Chain number	Dimensions		Style of top A or B	Overall width (riveted) $L_c$	End of pin to centre line (riveted) $L_0$	Barrel diameter $d_1$	Pin diameter $d_2$	Sprocket face width $b_1$	Overall barrel length $b$	Sidebar height $h_2$	Shoulder height $h_3$	Centre of pin to top height $h_4$	Overall height $h$	Sidebar thickness $t$	Average tensile strength	Designation
	Pitch	P														
-	mm	in	-	mm											kN	-
C 55 ACS	41,43	1,631	A	50,80	25,40	18,29	9,53	17,53	31,75	19,05	19,05	22,35	31,75	4,83	52,00	PHC C 55 ACS
C 55 BCS	41,43	1,631	B	50,80	25,40	18,29	9,53	17,53	31,75	19,05	19,05	22,35	31,75	4,83	52,00	PHC C 55 BCS
C 55 DCS	41,43	1,631	D	50,80	25,40	18,29	9,53	17,53	31,75	22,35	22,35	22,35	31,75	4,83	52,00	PHC C 55 CCS

Standard lengths are 10 ft and 5 m. To complete designation add chain length. For example, to order C 55 A in 10 ft length, use designation PHC C 55 AX10FT.

# Conveyor chains

## – basic maintenance notes

### General information

Conveyor chains of any type should be checked regularly. The frequency of the inspections will be, for the most part, dependent on the industry standards, which might in turn be established by the application, cycle / operation time, temperature and environment.

Given the ability of a chain to perform is essentially the sum of the integrity of ALL system components e.g pins, bushings, rollers, inner and outer side bars, attachments (if applicable), cotter pins and rivets) it is important to check the chain as thoroughly as possible.

### General conveyor inspection

The initial inspection process should include alignment checks, both of the chain and of the sprockets in relation to the frame. (The framework itself should be rigid enough not to allow flexing or bending under normal operational conditions).

Any offset or misalignment will quickly show up as wear on both the sprocket tooth face and on the inner plates of the chain. Inspection of rollers with uneven patterns over their contact length may also indicate alignment issues.

Any worn or damaged teeth will damage the chain links, and increase power consumption. Therefore, sprockets should be replaced if they show any signs of wear or damage.

### Chain wear / elongation

Over a period of time, wear between the pins and the bushings is inevitable. While seemingly insignificant on its own, the total amount over the length of the chain can be significant. Wear is often incorrectly referred to as 'stretch'. For most chains, this elongation effect should be no more than 3 to 5 % of the chain pitch. Figures over this (smaller for some chains) will cause the chain to 'ride

up' on the sprocket teeth, and in extreme cases 'jump off' the sprocket.

Once the chain has reached this elongation value, wear will accelerate, to further damage the chain and chain wheel / sprocket. It is therefore imperative to monitor chain elongation and take the appropriate action.

If chain elongation / wear occurs prematurely, the chain should be checked to detect any problems with components, (e.g. worn or loose pins, side bars hole elongation etc.). If any damage / defects are found, corrective action should be taken as to the cause. If no obvious cause is found the chain specification should be checked against requirements / actual load conditions.

### Maintenance of chains

The life of any type of chain depends on the integrity of the pin / bushing / side bar connections. Any factor that has a negative influence on the integrity of the chain should be eliminated or at least reduced to a minimum. This includes both installation and fitment of connectors, links etc., and the inspection and replacement of pins.

On many chains, pins can have several diameters. Some have an interference fit while others use flats or 'D' shaped ends. The pin, no matter what shape it is, must mate securely with the corresponding side plate holes. When dismantling the chain, the position of the flat, or depth of the secondary diameters should be noted. Checks and measures should be made and reconfirmed against drawings, if necessary to ensure that the pin is secure and fully retained.

To this end a hydraulic press is the most convenient and safest way to reset or replace pins and connectors.

The chain itself, at this point of maintenance, should be secured on a flat bed or table, capable of taking both the chain weight and any applied forces that it may be subjected to during the maintenance process. Be sure that the machine is locked out and tagged out and that the shaft(s) are secured.

Depending on the chain type, use the recommended maintenance procedures for the best and safest results.

For simplicity and ease of installation:

- For riveted pins, the riveted end must be ground off
- If the pin was fixed by a welded washer, it will be necessary to cut this connection. In this case, the pins will be replaced by a new one
- For pins fixed by cotter (or circlips); only remove the cotter head, before pressing out from the same side

For NEW PIN installation,

- Do NOT grind the pin diameter to make the fit more easily. The fit and tolerance should be as tight as recommended for full chain integrity
- Do NOT use a torch to heat the pin or side plate. This could have a detrimental effect on the mechanical and metallurgical characteristics of the metal
- Do NOT use heavy impact force to drive the pin in place. (The impact shocks may cause damage to other chain components, particularly in relation to their fit). Additionally, any broken / fractured part may cause serious personal injury

### Sprockets / chain wheels

The sprocket or, chain wheel, has a direct effect on chain behaviour, both at the drive end and the tail (idler) end.

If not correctly aligned to each other (this is more critical on short centres) and to the structure, the chain and sprocket will wear quickly.

There are three main dimensions that must be compliant for a chain to mesh efficiently with a sprocket wheel

- Chain pitch
- Roller, bushing or barrel diameter
- Inner width

In many cases, sprockets can be supplied with 'split hubs' for easy installation, making it unnecessary to remove shafts and bearings. Sprockets with detachable tooth profiles (segments) are also available, offering quick and convenient change-out with minimal downtime. If the chain is running in one direction only, it may be worth considering for a one or two piece sprocket in having the sprocket design symmetrical (with regards to boss length and location) to allow the sprocket to be reversed at a later date.

For good system chain life, it is important that the sprocket or chain wheel is inspected as frequently as the chain itself. Worn, or improperly designed and installed sprockets are one of the main causes for premature failure and reduced chain life.

An easy way to check sprocket wear on future sprockets is to make a 'template' from thick cardboard from the sprocket when new. Any wear will be easily detected by checking against the template at a later date.

**(Note:** In certain industries, where temperature, fire risk, hygiene, contamination etc. are an issue, it is accepted lubrication is not possible nor feasible.. Accordingly, with these exceptions, the probable poor wear and life is part of the selection process, with decisions of materials and hardening processes etc, made to try and get a better operational life, but one that will always be less than that of a correctly lubricated and maintained system).

## Lubrication

Proper lubrication is essential for good chain through life. The correct lubricant can also reduce noise levels and reduce energy consumption.

The method, quantity, quality and location of the lubrication may vary from industry to industry and from chain type to chain type. The lubricant is usually applied at the most 'open' point for the chain. This is usually just after the drive sprocket on the slack strand. At this time the lubricant has the best opportunity to work its way into the bushing / pin / roller area as the chain is not under tension.

The lack of any lubrication will have a detrimental effect on chain life due to excessive wear, noise and vibration. All are potential sources of energy loss, and therefore contribute to an inefficient overall conveyor system.

A poor lubrication condition can increase the power consumption from 15 to 35% depending on the chain style, type and system load!

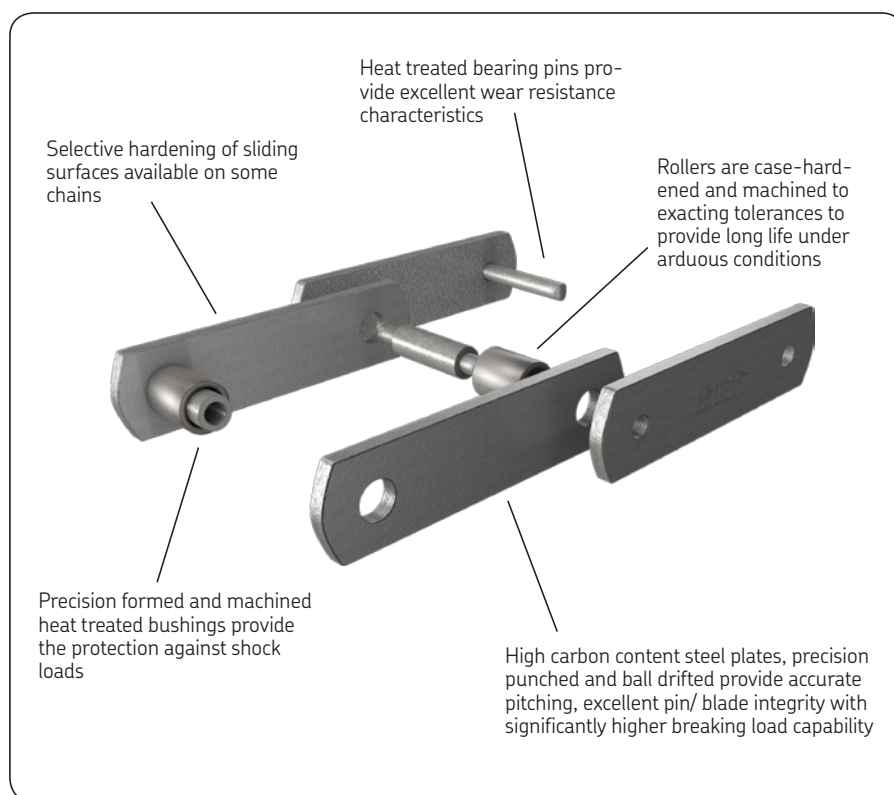













© SKF is a registered trademark of the SKF Group.

© SKF Group 2011

The contents of this publication are the copyright of the publisher and may not be reproduced (even extracts) unless prior written permission is granted. Every care has been taken to ensure the accuracy of the information contained in this publication but no liability can be accepted for any loss or damage whether direct, indirect or consequential arising out of the use of the information contained herein.

PUB PT/P2 10818 EN · July 2011