

Condition Monitoring Essentials



Global presence – local solutions

With over 100 years of experience, SKF stands alone as a total solution provider for maximizing machine and plant productivity. With a reputation for quality, technological innovation and service that spans the globe, SKF brings what no other vendor can to the maintenance arena.

Local SKF sales and service representatives and worldwide distributors provide access to the range of SKF bearings, maintenance products, lubricants, condition monitoring instrumentation and software, independent of your location.

In any kind of rotating machinery, from huge rolling machines to the smallest of motors, the bearing knows if there is a potential problem. As the primary interface between moving parts, the bearing is literally the diagnostic heart of the machine.

Misalignment, unbalance, looseness and friction are all telegraphed through the bearing. Understanding the information coming from this diagnostic “pulse” and then applying the latest and best technology to the problem is the key to raising machine productivity and lowering operating costs.

This SKF condition monitoring essentials product catalogue features a convenient collection of monitoring tools that no industrial manufacturing plant should be without.

Contents

SKF standard product offering

Description	Page	Description	Page	Description	Page
 SKF Machine Condition Advisor CMAS 100-SL	6	 SKF Machine Condition Detector Pro IS CMVL 3600-IS	25	 Junction boxes and enclosures CMSS 260, CMSS 265, CMSS 300 and CMSS 310 series	39
 SKF Infrared Thermometer CMSS 3000-SL	11	 Loop-powered vibration transmitters series CMSS 420VT / CMCP 420 VT-T	29	 NEMA 4 and NEMA 4X enclosures CMSS 260 series	40
 SKF Inspector 400 Ultrasonic Probe CMIN 400-K	13	 General purpose industrial accelerometer CMSS 2100	32	 Termination junction boxes CMSS 265 series	41
 SKF Basic Condition Monitoring kit CMAK 400-ML	16	 General purpose, low profile, side exit, industrial accelerometer CMSS 2200 / CMSS 2200-M8	34	 BNC junction boxes CMSS 300 series	42
 SKF Bearing Assessment kit CMAK 300-SL	17	 Vibration sensor cables CMSS 93x series	36	 Switchable BNC junction boxes CMSS 310 series	44
 SKF Electric Motor Assessment kit CMAK 200-SL	18	 Industrial cable connector assemblies for vibration sensors CMSS 932-68	37	 SKF Machine Condition Transmitter (MCT) systems CMSS 5301 / CMSS 5302	47
 SKF Wireless MicroVibe CMVL 4000-EN	20				

SKF – the knowledge engineering company

From one simple but inspired solution to a misalignment problem in a textile mill in Sweden, and fifteen employees in 1907, SKF has grown to become a global industrial knowledge leader.



Over the years we have built on our expertise in bearings, extending it to seals, mechatronics, services and lubrication systems. Our knowledge network includes 46 000 employees, 15 000 distributor partners, offices in more than 130 countries, and a growing number of SKF Solution Factory sites around the world.

Research and development

We have hands-on experience in over forty industries, based on our employees' knowledge of real life conditions. In addition our world-leading experts and university partners who pioneer advanced theoretical research and development in areas including tribology, condition monitoring, asset management and bearing life theory. Our ongoing commitment to research and development helps us keep our customers at the forefront of their industries.

Meeting the toughest challenges

Our network of knowledge and experience along with our understanding of how our core technologies can be combined helps us create innovative solutions that meet the toughest of challenges. We work closely with our customers throughout the asset life cycle, helping them to profitably and responsibly grow their businesses.

Working for a sustainable future

Since 2005, SKF has worked to reduce the negative environmental impact from our own operations and those of our suppliers. Our continuing technology development introduced the SKF BeyondZero portfolio of products and services which improve efficiency and reduce energy losses, as well as enable new technologies harnessing wind, solar and ocean power. This combined approach helps reduce the environmental impact both in our own operations and in our customers'.



SKF Solution Factory makes SKF knowledge and manufacturing expertise available locally, to provide unique solutions and services to our customers.



Working with SKF IT and logistics systems and application experts, SKF Authorized Distributors deliver a valuable mix of product and application knowledge to customers worldwide.



Our knowledge – your success

SKF Life Cycle Management is how we combine our technology platforms and advanced services, and apply them at each stage of the asset life cycle, to help our customers to be more successful, sustainable and profitable.

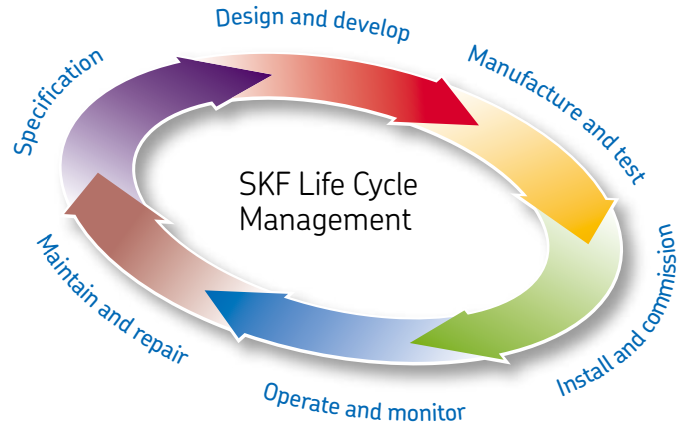

Working closely with you

Our objective is to help our customers improve productivity, minimize maintenance, achieve higher energy and resource efficiency, and optimize designs for long service life and reliability.



Bearings

SKF is the world leader in the design, development and manufacture of high performance rolling bearings, plain bearings, bearing units and housings.

Innovative solutions

Whether the application is linear or rotary or a combination of the two, SKF engineers can work with you at each stage of the asset life cycle to improve machine performance by looking at the entire application. This approach doesn't just focus on individual components like bearings or seals. It looks at the whole application to see how each component interacts with the next.



Machinery maintenance

Condition monitoring technologies and maintenance services from SKF can help minimize unplanned downtime, improve operational efficiency and reduce maintenance costs.

Design optimization and verification

SKF can work with you to optimize current or new designs with proprietary 3-D modeling software that can also be used as a virtual test rig to confirm the integrity of the design.



Sealing solutions

SKF offers standard seals and custom engineered sealing solutions to increase uptime, improve machine reliability, reduce friction and power losses, and extend lubricant life.



Mechatronics

SKF fly-by-wire systems for aircraft and drive-by-wire systems for off-road, agricultural and forklift applications replace heavy, grease or oil consuming mechanical and hydraulic systems.



Lubrication solutions

From specialized lubricants to state-of-the-art lubrication systems and lubrication management services, lubrication solutions from SKF can help to reduce lubrication related downtime and lubricant consumption.



Actuation and motion control

With a wide assortment of products – from actuators and ball screws to profile rail guides – SKF can work with you to solve your most pressing linear system challenges.

SKF Machine Condition Advisor

CMAS 100-SL

Machine monitoring, made simple

Now both novice users and experts can easily, quickly, and accurately check the condition of rotating equipment throughout your facility. Equipping your maintenance and operations personnel with this rugged, ergonomic and easy-to-use instrument can provide early warning of potential machine problems before a costly failure occurs.



SKF Machine Condition Advisor simultaneously measures vibration signals and temperature to indicate machine health or bearing damage.

Features

- Quick and easy to set up and use, measurements are shown on a bright display viewable in low light to direct sunlight. Free on-line training is also available at SKF @ptitude Exchange.
- Lightweight, compact, and ergonomically designed, the SKF Machine Condition Advisor fits neatly at the belt line, in a pocket or a tool kit. Exceptionally durable, the unit is rated IP 54 for use in industrial environments.
- Alert and Danger prompts provide increased diagnostic confidence.
- Measuring velocity, enveloped acceleration and temperature simultaneously saves time.
- Efficient, economical and environmentally friendly, the rechargeable SKF Machine Condition Advisor operates 10 hours on a single charge.
- Flexible enough to work with standard 100 mV/g constant current accelerometers, an optional external sensor can be used for hard-to-reach locations and for more repeatable and accurate measurement results.
- Features English, French, German, Portuguese, Spanish and Swedish for user convenience.

Multiple measurements with a single device

The SKF Machine Condition Advisor provides an overall “velocity” vibration reading that measures vibration signals from the machine and automatically compares them to pre-programmed International Organization for Standardization (ISO) guidelines. An “Alert” or “Danger” alarm displays when measurements exceed those guidelines. Simultaneously an “enveloped acceleration” measurement is taken and compared to established bearing vibration guidelines to verify conformity or indicate potential bearing damage.

The SKF Machine Condition Advisor also measures temperature using an infrared sensor to indicate uncharacteristic heat.

Accuracy, flexibility and confidence

When performing measurements, the SKF Machine Condition Advisor’s acceleration sensor input signal is processed to produce two different measurements for each POINT on the machinery – overall velocity and enveloped acceleration.



At the same time, the SKF Machine Condition Advisor's non-contact infrared sensor measures the surface temperature of the measurement location and simultaneously displays all three measurement values.

Depending on the SKF Machine Condition Advisor's System setting, the front-panel LCD simultaneously displays:

- Metric or Imperial units
- Velocity in mm/s RMS or in./s derived Peak
- Temperature in Celsius or Fahrenheit
- Acceleration enveloping readings in gE

Quick and easy – first time and every time

- 1 Press **Select** or **Browse** button to turn the SKF Machine Condition Advisor "On".
- 2 Press the sensor tip against the point to be measured.
- 3 When the readings stabilize, press the **Select** button to hold the reading.
- 4 Read and record the measurement values.

Specifications

- Vibration pickup:
 - Internal: Integrated piezoelectric acceleration
 - External: Accepts a standard 100 mV/g constant current accelerometer
- Temperature sensor: Internal infrared temperature sensor
- Measurements:
 - Velocity:
 - Range: 0,7 to 65,0 mm/s (RMS) (0.04 to 3.60 in./s (equivalent Peak)), meets ISO 10816-3
 - Frequency: 10 to 1 000 Hz, meets ISO 2954

- Enveloped acceleration:
 - Range: 0,2 to 50,0 gE
 - Frequency: Similar to Band 3 (500 to 10 000 Hz)
- Temperature:
 - Range: –20 to +200 °C (–5 to +390 °F)
 - Infrared temperature accuracy: 2 °C (4 °F)
 - Distance: Short range, maximum 10 cm (4 in.) from target
- Operating temperature range:
 - In use: –10 to +60 °C (15 to 140 °F)
 - While charging: 0 to 40 °C (30 to 105 °F)
- Storage temperature:
 - Less than one month: –20 to +45 °C (–5 to +115 °F)
 - More than one month, but less than six months: –20 to +35 °C (–5 to +95 °F)
- Humidity: 95% relative humidity, non-condensing
- Enclosure: IP 54
- Approvals: CE
- Drop test: 2 m (6.6 ft.)
- Weight: 125 g (4.4 oz.)
- Dimensions:
 - Length: 200,0 mm (7.90 in.)
 - Width: 47,0 mm (1.85 in.)
 - Height: 25,4 mm (1.00 in.)
- Battery life: 10 hours before charging again (≈ 1 000 measurements)
 - With external sensor: Up to 55% less battery life
- Supported external sensor: Any standard accelerometer with 100 mV/g sensitivity constant current
- External sensor power: 24 V DC at 3,5 mA
- Charger specifications:
 - Universal AC/DC wall plug-in
 - Input: 90 to 264 V AC, 47 to 60 Hz
 - Output: 5 V DC regulated
 - 3 to 4 hours for a full charge

LCD display in measurement mode

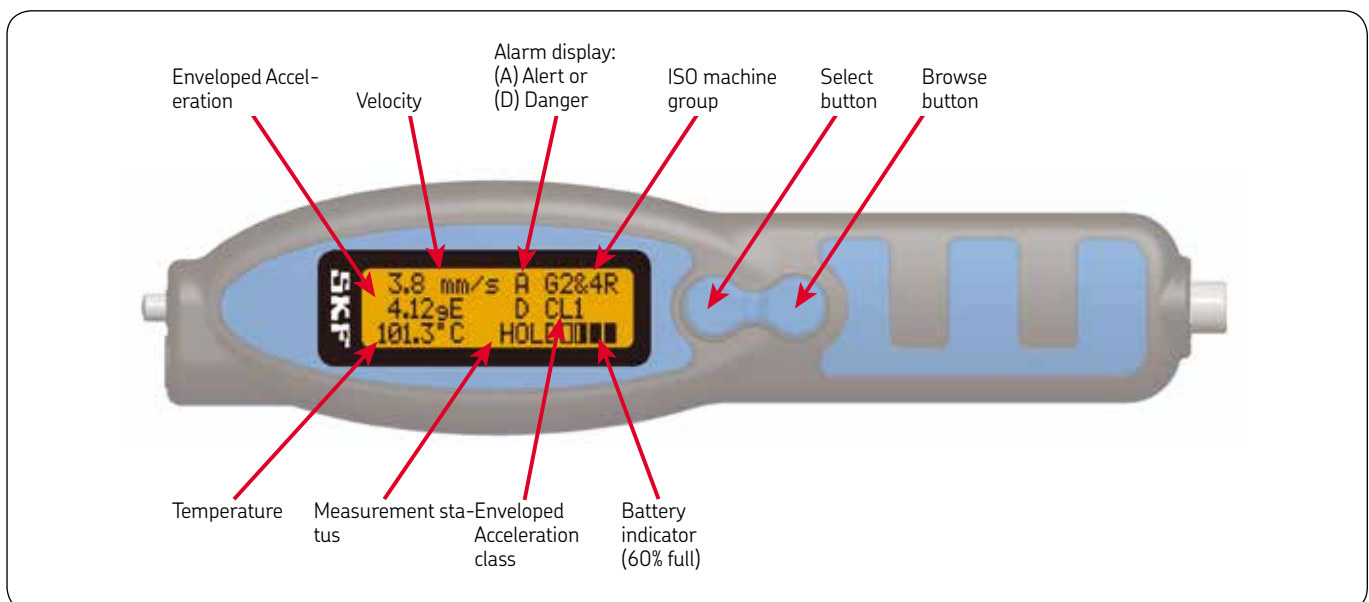

Understanding and using guidelines for vibration

The SKF Machine Condition Advisor provides a means to evaluate machine health based on ISO 10816-3 and to evaluate the bearings according to general guidelines developed from a statistical analysis of existing databases.

How to choose the correct “Alarm Velocity Group” for your machinery

The Alarm Velocity Group (**G2&4** or **G1&3**) determines the instrument’s “overall vibration” alarm limits. Therefore, select the Group that best describes the general size, type, and speed of the machinery being measured. Note that these machine group classifications are set forth in ISO 10816-3, which rates overall velocity vibration levels for standardized machinery classifications.

Groups 2 and 4 (default)

ISO Group 2 and 4 classifications define the following type of machinery:

- Medium-sized machines and electrical machines with a shaft height between 160 and 315 mm (6.3 and 12.4 in.).
- These machines are normally equipped with rolling element bearings, but may use sleeve bearings, and operate at speeds above 600 r/min.
- These machines include pumps with multi-vane impellers and integrated drivers.

Groups 1 and 3

ISO Group 1 and 3 classifications define the following type of machinery:

- Large machinery and electrical machines with a shaft height greater than 315 mm (12.4 in.).
- These machines are generally equipped with sleeve bearings, but may use rolling element bearings.
- These machines include pumps with multi-vane impellers and separated drivers.



Rigid or Flexible foundation?

An additional setting allows the specification (when defining the overall alarm levels) of measurements taken from machinery with **rigid** (default) or **flexible** foundations.

Options are:

G2 and 4R (default)

Alert: 2,8 mm/s (0.16 in./s)
Danger: 4,5 mm/s (0.25 in./s)

G2 and 4F

Alert: 4,5 mm/s (0.25 in./s)
Danger: 7,1 mm/s (0.39 in./s)

G1 and 3R

Alert: 4,5 mm/s (0.25 in./s)
Danger: 7,1 mm/s (0.39 in./s)

G1 and 3F

Alert: 7,1 mm/s (0.39 in./s)
Danger: 11,0 mm/s (0.61 in./s)

How to choose the correct “Enveloped Acceleration Classification” for your machinery

The Enveloped Acceleration Classification (**CL1**, **CL2** or **CL3**) you specify determines the instrument’s “bearing vibration” alarm levels. Therefore, the Enveloped Acceleration Classification that best describes the general size and speed of the bearings being measured should be selected.

Options are:

CL1

Bearings with a bearing bore diameter between 200 and 500 mm (7.9 and 19.7 in.) and a shaft speed below 500 r/min.
Alert: 1 gE
Danger: 2 gE

CL2 (default)

Bearings with a bearing bore diameter between 50 and 300 mm (2.0 and 11.8 in.) and a shaft speed between 500 and 1 800 r/min.
Alert: 2 gE
Danger: 4 gE

CL3

Bearings with a bearing bore diameter between 20 and 150 mm (0.8 and 5.9 in.) and a shaft speed from 1 800 to 3 600 r/min.
Alert: 4 gE
Danger: 10 gE

Note:

As with all commonly published severity guidelines, the above provides target thresholds for new, refurbished and recently maintained equipment.

In addition, if both lower limits of the guideline are used (for example in CL2, a 50 mm bearing bore diameter at 500 r/min), the applicable alarm values maybe lower. Note that bearing bore diameter is equal to shaft height.

Expanding your capabilities with SKF Machine Condition Advisor compatible accessories

Extension sensor kit, Model CMAC 112-K

The extension sensor kit CMAC 112-K contains an accelerometer with coiled integral cable (CMAC 111) and magnet (CMAC 109) with mounting stud. This kit is needed to take measurements from hard-to-reach places and for more repeatable and accurate measurement results.



CMAC 112-K extension sensor kit

Accelerometer

- 100 mV/g sensitivity
- Small size case
- 0,4 to 12 000 Hz frequency response (± 3 dB)
- Submersible

CMAC 111 accelerometer dimensions

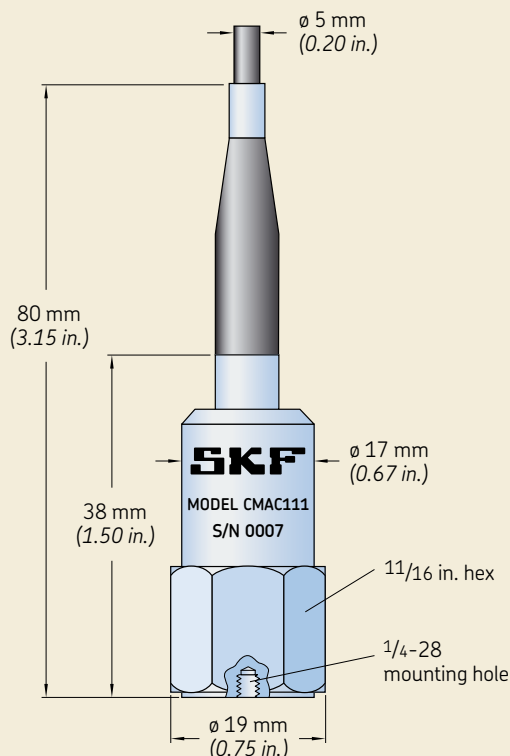

Accelerometer specifications:

Dynamic performance

- Sensitivity ($\pm 15\%$): 10,2 mV/(m/s²) (100 mV/g)
- Dynamic range: 784 m/s² (80 g peak)
- Frequency response:
 - ± 3 dB: 24 to 720 000 CPM (0,4 to 12 000 Hz)
 - $\pm 10\%$: 42 to 480 000 CPM (0,7 to 8 000 Hz)
 - $\pm 5\%$: 60 to 360 000 CPM (1,0 to 6 000 Hz)

Electrical

- Voltage source: 18 to 30 V DC
- Constant current excitation: 2 to 10 mA
- Spectral noise at:
 - 10 Hz: 7 μ g/ $\sqrt{\text{Hz}}$
 - 100 Hz: 4 μ g/ $\sqrt{\text{Hz}}$
 - 1 000 Hz: 2 μ g/ $\sqrt{\text{Hz}}$
- Output impedance: < 100 Ω
- Bias output voltage: 12 V DC
- Grounding: Case isolated, internally shielded

Physical

- Sensing element and structure: PZT, shear
- Weight: 150,5 g (3.5 oz.)
- Case material: 316L stainless steel
- Mounting: 1/4-28 tapped hole
- Resonant frequency: 1 800 000 CPM (30 000 Hz)
- Calibration certificate: CAL-Cert CMAC 111

Environmental

- Temperature range:
 - Sensor head: -50 to $+120$ °C (-60 to $+250$ °F)
 - Cable: -40 to $+80$ °C (-40 to $+175$ °F)
- Maximum shock protection: 49 km/s² peak (5 000 g peak)
- Electromagnetic sensitivity: CE
- Sealing welded: Hermetic
- Hydrostatic pressure: 100 psi

Integral cable

- Connector to SKF Machine Condition Advisor CMAS 100-SL
- Cable length:
 - Cable length at rest: 0,95 m (3.0 ft.)
 - Cable length extended: 2,3 m (7.5 ft.)

Magnet

- 14 kg (30 lbs.) pull-strength
- 25 mm (1 in.) diameter
- 1/4-28 mounting hole
- Case material: Stainless steel
- Magnet material: Neodymium

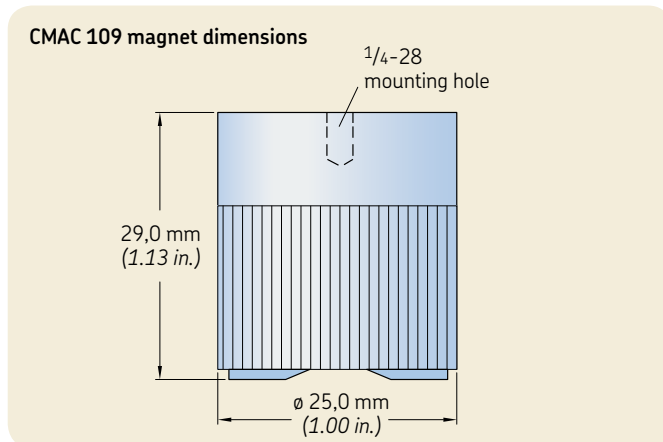

Connection cable (1,5 m), Model CMAC 107

Optional connection cable for standard constant current accelerometers with 100 mV/g, MIL-SPEC connector.



CMAC 107 connection cable

Ordering information

SKF Machine Condition Advisor CMAS 100-SL includes:

- SKF Machine Condition Advisor unit
- Belt holster [CMAC 102]
- Charger, international DC power supply [CMAC 8004]
- User manual, English hard copy [32131800-EN]
- CD containing:
 - User manual available in PDF files in English, French, German, Portuguese, Spanish and Swedish
 - Link to training on SKF @ptitude Exchange
 - SKF Machine Condition Advisor trend worksheet (Excel .xls file)
 - SKF Condition Monitoring Essentials catalog available in PDF file in English [CM/P1 11704 EN]

Accessories

- Extension kit, 100 mV/g accelerometer with coiled integral cable and magnet [CMAC 112-K]
- Connection cable, 1,5 m with M8 socket type connector for standard constant current 100 mV/g accelerometer [CMAC 107]

Replacement

- Charger, international DC power supply, +5 V, 1 600 mA, 90 to 264 V AC, 47 to 63 Hz [CMAC 8002]
- Magnet, magnet base, 1,0 in. diameter, 30 lbs. pull-strength [CMAC 109]
- Belt holster [CMAC 102]

Optional kits that include the SKF Machine Condition Advisor CMAS 100-SL

- SKF Basic Condition Monitoring kit [CMAK 400-ML]
- SKF Electric Motor Assessment kit [CMAK 200-EN]
- SKF Bearing Assessment kit [CMAK 300-SL]

SKF Infrared Thermometer

CMSS 3000-SL

Heavy duty, long range, dual laser sighted non-contact infrared thermometer

There are many uses for this handheld non-contact, infrared thermometer. Rugged and easy to use – just aim, pull the trigger and read the temperature in less than a second. Measures surface temperatures of hot, hazardous, moving or hard-to-reach objects safely without contact.

Features

- Dual point laser sighting
- Adjustable emissivity
- 50:1 distance to spot size ratio
- Temperature range: -60 to $+1\ 000$ °C (-75 to $+1\ 800$ °F)
- Exceptional battery life
- High and low alarm
- MAX, MIN, DIF, AVG temperature displays
- Amber back-light LCD display
- High intensity white LED flashlight
- Heavy duty magnet in base of handle
- Hard case

Description

The non-contact thermometer senses the thermal energy radiated from an object with an infrared detector. When pointed at an object, the infrared detector collects energy producing a signal that the microprocessor translates as a reading on the backlit display. As the trigger is squeezed, the object temperature is continuously measured by the infrared detector. This allows for fast and accurate real-time readings.

This instrument features an extended temperature range -60 to $+1\ 000$ °C (-75 to $+1\ 800$ °F); dual laser sighting; bright large amber back-light LCD display; Maximum, Minimum, Difference (MAX-MIN) and "Lock" function for continuous temperature scanning; programmable High and Low audible alarms; selectable temperature units (°C or °F); low battery indicator, and adjustable emissivity for more accurate temperature measurements.



Dual laser sighting and distance to spot ratio

Dual lasers provides easy aiming and defines the target area. The target area is highlighted at all distances with two laser dot markers. Laser 1 indicates one point of the measurement spot on one side of the target area to be measured and Laser 2 indicates the location of the diametrically opposed point on the other side of the measurement spot. At the focal point, where the spot size is the smallest, the dots line up vertically, rotating as the SKF Infrared Thermometer is moved closer or further from the target.

Emissivity

Emissivity is a term used to describe the energy-emitting characteristics of materials. Most organic materials and painted or oxidized surfaces have an emissivity of 0,95. Inaccurate readings can result from measuring shiny or polished metal surfaces. To compensate for this, adjust the unit's emissivity reading, or cover the surface to be measured with masking tape or flat black paint (< 150 °C / 300 °F). Allow time for the tape or paint to reach the same temperature as the material underneath it. Measure the temperature of the tape or painted surface.

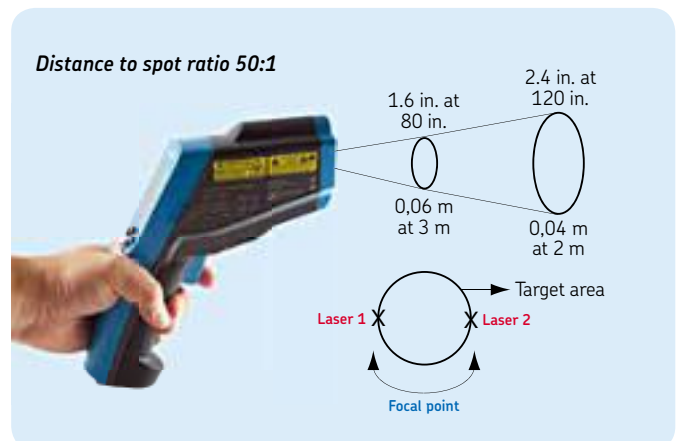

Hard case

A water resistant, dust-proof case which holds the unit (and magnetic stand) and measures 330 × 197 × 66 mm (13.00 × 7.75 × 2.60 in.) is included.

Specification

- Measurement range: -60 to +1 000 °C (-75 to +1 800 °F)
- Operating range: 0 to 50 °C (30 to 120 °F)
- Accuracy (T_{object} = 15 to 35 °C (60 to 95 °F), T_{ambient} = 25 °C (75 °F)): ±1 °C (±2 °F)
- Accuracy (T_{object} = 35 to 1 000 °C (90 to 1 800 °F); T_{ambient} = 25 °C, ±3 °C (75 °F, ±5 °F)): ±2% of reading or +2 °C (+4 °F), whichever is greater
- Update frequency: 1,4 Hz
- Wave length response: 8 to 14 µm
- Emissivity range: 0,95 default – adjustable 0,1 to 1 step 0,01
- Relative humidity: 5 to 95% non-condensing
- Resolution, from -9,9 to +199,9 °C (14.2 to 391.8 °F): 0,1 °C (0.2 °F)
- Response time (90%): < 1 sec
- Distance spot ratio: 50:1
- Dimensions:
 - Height: 203,3 mm (7.90 in.)
 - Width: 197,0 mm (7.71 in.)
 - Depth: 47,0 mm (1.85 in.)
- Weight: 386,1 g (13.62 oz.) including batteries
- Power: Two AAA batteries (included)
- Battery life: Typical 180 hours, minimum 140 hours continuous use (Alkaline, without laser and back light)

- Modes: Maximum, Minimum, Average, Difference (MAX-MIN), Lock (allows for continuous temperature scan)

Note:

Under an electromagnetic field of 3 V/m from 90 to 360 MHz the maximum error is ±10 °C (±18 °F).

National Institute of Standards and Technology (NIST), traceable factory calibration available.

Ordering information

- SKF non-contact Infrared Thermometer, including quick start guide in standard languages (English, French, German, Portuguese, Spanish and Swedish), two AAA batteries, hard carrying case and magnetic stand [CMSS 3000-SL]
- DOC-CAL CERT CMSS 3000, NIST Certificate of Calibration Accuracy (Watlow-Gordon XACT-CAL)



LCD display



Optional kits that includes the SKF Infrared Thermometer, CMSS 3000-SL

- SKF Basic Condition Monitoring kit [CMAK 400-ML]
 - SKF Machine Condition Advisor [CMAS 100-SL]
 - Extension kit, 100 mV/g accelerometer with coiled integral cable and magnet [CMAC 112-K]
 - SKF Infrared Thermometer [CMSS 3000-SL]
 - SKF Inspector Ultrasonic Probe [CMIN 400]
- SKF Bearing Assessment kit [CMAK 300-SL]
 - SKF Machine Condition Advisor [CMAS 100-SL]
 - SKF Infrared Thermometer [CMSS 3000-SL]
 - SKF OilCheck [THEH1]

SKF Inspector 400 Ultrasonic Probe

CMIN 400-K

Complements your condition monitoring program

The analog SKF Inspector 400 Ultrasonic Probe is easy to use and can detect early stages of machine problems.

This small approach to inspection can save money, energy and time.

Features

- Detect pressure and vacuum leaks, including compressed air
- Check steam traps and valves quickly and accurately
- Detect arcing, tracking and corona in electric apparatus
- Test bearings, pumps, motors, compressors, etc.

Description

The SKF Inspector 400 Ultrasonic Probe senses high frequency sounds produced by operating equipment, leaks and electrical discharges. It electronically translates these signals by a heterodyning process, making them audible, so that a user can hear these sounds through a headset and see them as intensity increments on a meter.

The SKF Inspector 400 Ultrasonic Probe can complement your condition monitoring program by providing you with the following capabilities:

Pressure/Vacuum leaks

As any gas (air, oxygen, nitrogen, etc.) passes through a leak orifice, it generates a turbulent flow with detectable high frequency components. By scanning the test area with the SKF Inspector 400



Ultrasonic Probe, a leak can be heard through the headset as a rushing sound or noted on the meter bar graph indicator. The closer the instrument is to the leak, the louder the rushing sound and the higher the meter reading. Should ambient noise be a problem, a rubber focusing probe may be used to narrow the instrument's reception field and to shield it from conflicting ultra sounds.

Valve

Valve activity such as leakage or blockage can be accurately checked while the valve is on line. Properly seated valves are relatively quiet while leaking valves produce a turbulent flow as the fluid moves from the high pressure side through the leak to the low pressure side. Due to a wide sensitivity and ultrasonic frequency, all types of valves even in noisy environments can be accurately tested.

Valve stems

Valve stems may be quickly tested for leaks to atmosphere.

Valve leakage



Pressure/Vacuum leaks



Steam trap inspection

Major steam trap manufacturers have recommended ultra sound inspection of steam traps as one of the most reliable methods available. By converting the ultrasonic elements of a working steam trap into the audible range, the SKF Inspector 400 Ultrasonic Probe allows users to hear through headphones and see on a meter the exact condition of a steam trap while it is on line. Blowby, machine gunning, oversized traps or line blockage are all easily detected.

The SKF Inspector 400 Ultrasonic Probe markedly reduces confusion from extraneous sounds or from heat transfer, even when traps are extremely close together.

Electrical inspection

Arcing and corona discharge emit ultra sounds at the site of emission. This electrical discharge can be located quickly by scanning the area with the SKF Inspector 400 Ultrasonic Probe. The signal is heard as a frying or buzzing sound in the headset. As with pressure or vacuum leak detection, the closer the instrument is to the discharge, the more intense the signal.

Test switch gear, transformers, circuit breakers, buss bars, relays, junction boxes, insulators and other electrical gear.

General mechanical inspection

The SKF Inspector 400 Ultrasonic Probe can detect the early stage of a machine's mechanical malfunction. NASA research has demonstrated that ultrasound monitoring will locate potential bearing deficiencies before they are detected by the traditional heat and vibration methods. With the SKF Inspector 400 Ultrasonic Probe, users hear the sound quality of a bearing as well as monitor amplitude changes on the meter. This complements other monitoring instruments and adds to the ability to trend, troubleshoot, and confirm potential bearing problems.

General mechanical inspection is easy with the SKF Inspector 400 Ultrasonic Probe and with very little training, users can learn to test bearings within minutes. Current vibration programs can achieve enhanced diagnostic ability with the SKF Inspector 400 Ultrasonic Probe.

Prevent over-lubrication with the SKF Inspector 400 Ultrasonic Probe by simply lubricating only until the meter reaches a specified level. Over lubrication is one of the more common causes of bearing failure.

General mechanical inspection of pumps, motors, compressors, gears and gear boxes: all types of operating equipment may be inspected with the SKF Inspector 400 Ultrasonic Probe. Since the SKF Inspector 400 Ultrasonic Probe works in a high frequency, short wave environment, problems such as cavitation in pumps, compressor valve leakage, or missing gear teeth may be heard and isolated. Reciprocating compressor valve analysis has also become successful with the SKF Inspector 400 Ultrasonic Probe and therefore many engine analyzer companies now offer instruments with an ultrasonic input port.

Heat exchangers, boilers and condensers

In-leakage or pressure leakage can be readily located with the SKF Inspector 400 Ultrasonic Probe. Fittings, valves and flanges are all easily scanned for leakage. The high frequency, short wave nature of ultrasound allows operators to pinpoint the location of a leak in high noise environments.

Condenser tubes and heat exchanger tubes may be tested for leakage through two methods: **vacuum** and **pressure**.

Vacuum

The tube sheet is scanned for the tell-tale rushing sound produced as the leak draws air into the tube.

Pressure

Additional testing may be performed when the system is off-line utilizing air pressure around the tube bundle and scanning for the rushing sound produced from the leaking tube.

Applications

- Pressure and vacuum leak detection
- Valve seat leak detection
- Exhaust system leaks
- Heat exchangers, boilers, condensers
- Steam trap inspection
- Bearing testing
- Gear/Gearbox inspection
- General mechanical inspection and troubleshooting
- Tanks, pipes, etc., leak testing

Tank leakage



Mechanical inspection



SKF Inspector 400 Ultrasonic Probe Stethoscope/Scanner kit includes:

- SKF Inspector 400 Ultrasonic Probe pistol housing with LED bar graph meter, eight-position sensitivity selection, low battery indicator
- Scanning module
- Rubber focusing probe
- Stethoscope module
- Lightweight foam lined headset
- 9 V alkaline battery (replaceable)
- Cordura/Nylon soft pack carrying case
- Comprehensive instruction manual (English language)

Specifications

- Construction: Handheld ABS pistol type ultrasonic processor, stainless steel sensor enclosures
- Circuitry: SMD / solid state hybrid heterodyne receiver
- Frequency response: 20 to 100 kHz (centered at 38 to 42 kHz)
- Indicator: 10 segment LED bar graph (red)
- Sensitivity selection: Eight-position precision attenuation
- Power: 9 V alkaline battery
- Low battery voltage indicator: LED
- Headset: Lightweight foam lined double headset wired mono-
phonic impedance; 16 Ω
- Probes: Scanning module stainless steel unisonic (single transducer) piezoelectric crystal type; stethoscope/contact module stainless steel plug-in type with 14 cm (5.5 in.) stainless steel waveguide
- Rubber focusing probe: Shields stray ultrasonic signals and focuses detected signals
- Response time: 300 m/s
- Ambient operating temperature range: 0 to 50 °C (30 to 120 °F)
- Relative humidity: 10 to 95% non-condensing at up to 30 °C (85 °F)
- Storage temperature: -20 to 55 °C (0 to 130 °F)
- Dimensions:
 - Height: 133 mm (5.25 in.)
 - Width: 50 mm (2.00 in.)
 - Length: 203 mm (8.00 in.)
- Weight: 320 g (11 oz.)
- Carrying case: Cordura/Nylon soft pack with die cut foam

Ordering information

- SKF Inspector 400 Ultrasonic Probe Stethoscope/Scanner kit [CMIN 400-K] including:
 - Probe pistol housing with LED bar graph meter, eight-position sensitivity selection, low battery indicator, scanning module, rubber focusing probe, stethoscope module
 - Lightweight foam headset
 - 9 V alkaline battery
 - Instruction manual hard copy in English language



Accessories and replacement parts

- Lightweight foam lined headset [CMAC 8600-1]
- Deluxe noise isolating headphones [CMAC 8600-2]
- Deluxe noise isolating headphones to be worn with hard hat [CMAC 8600-3]
- Utility belt with holster [CMAC 8600-4]
- Stainless steel unisonic scanning module [CMAC 8600-6]
- Stainless steel stethoscope/contact module [CMAC 8600-7]
- Stethoscope extension rods [CMAC 8600-8]
- Rubber focusing probe [CMAC 8600-9]

Optional kits that includes the SKF Inspector 400 Ultrasonic Probe, CMIN 400-K

- SKF Basic Condition Monitoring kit [CMAK 400-ML]
 - SKF Machine Condition Advisor [CMAS 100-SL]
 - Extension kit, 100 mV/g accelerometer with coiled integral cable and magnet [CMAC 112-K]
 - SKF Infrared Thermometer [CMSS 3000-SL]
 - SKF Inspector Ultrasonic Probe [CMIN 400]

SKF Basic Condition Monitoring kit

CMAK 400-ML

An essential collection of measurement tools for all industrial manufacturing plants, the SKF Basic Condition Monitoring kit makes machine health monitoring a simple task for maintenance, operations, reliability and vibration analysis departments.

Features

- Assessment of overall machine condition
- Test bearings, pumps, motors, compressors, etc.

Multi-parameter machine assessment with the SKF Basic Condition Monitoring kit:

SKF Machine Condition Advisor CMAS 100-SL

The SKF Machine Condition Advisor simultaneously measures machine vibration signals and temperature to indicate machine health and bearing condition.

SKF external sensor kit for the SKF Machine Condition Advisor CMAC 112-K

The external vibration sensor with magnet provides convenience for hard-to-reach surfaces and more repeatable and accurate measurements.

SKF Infrared Thermometer CMSS 3000-SL

The heavy duty SKF Infrared Thermometer is a dual laser sighted, non-contact instrument for long range application.

SKF Inspector 400 Ultrasonic Probe CMIN 400-K

The SKF Inspector 400 Ultrasonic Probe senses high frequency sounds produced by operating equipment, leaks and electrical discharges and makes them audible. The SKF Basic Condition Monitoring kit features all of the accessories from the SKF Inspector 400 Ultrasonic Probe kit.

Carrying case

The instruments are packaged in a light, durable aluminium carrying case for industrial environments.

- Style: Riveted construction
- Weight: 2,6 kg (5.7 lb.) case only

For additional information on the instruments included in the kit, please refer to the previous, respective sections.

SKF Machine Condition Advisor



External sensor kit



SKF Infrared Thermometer



SKF Inspector 400 Ultrasonic Probe



Carrying case



- Dimensions:
 - Length: 450 mm (18 in.)
 - Width: 330 mm (13 in.)
 - Depth: 150 mm (6 in.)
- Material: 0.040 5052 H34 (or H32) aluminium – satin (mill) finish
- Features:
 - Valance (extrusion) – at joining ends (aluminium)
 - Continuous hinge (aluminium) – full length
 - Tubular handle (plated steel)
 - Two locking draw bolts (plated steel)
 - Eight reinforced corners (plated steel)
 - Four plastic bumpers – hinge side
 - Made in the USA
 - Briefcase pallet (faux leather)
 - Custom dye cut foam interior (1.3 lb/ft³ density)
- Color: Powder coated (blue)

Ordering information

SKF Basic Condition Monitoring kit [CMAK 400-ML] includes:

- SKF Machine Condition Advisor [CMAS 100-SL]
 - External sensor kit, 100 mV/g accelerometer with coiled integral cable and magnet [CMAC 112-K]
- SKF Infrared Thermometer [CMSS 3000-SL]
- SKF Inspector 400 Ultrasonic Probe kit [CMIN 400-K]
 - Ultrasonic Probe pistol housing with LED bar graph meter
 - Lightweight foam lined headset [CMAC 8600-1]
 - Stainless steel unisonic scanning module [CMAC 8600-6]
 - Stainless steel stethoscope/contact module [CMAC 8600-7]
 - Stethoscope extension rods [CMAC 8600-8]
 - Rubber focusing probe [CMAC 8600-9]

SKF Bearing Assessment kit

CMAK 300-SL

A convenient collection of measurement devices for all industrial manufacturing plants.

The basic SKF Bearing Assessment kit makes the assessment of bearing condition a simple task for maintenance, operations, reliability and vibration analysis departments.

Features

- Check bearing and lubrication condition
- Assessment of overall machine condition

Multi-parameter machine evaluation with the SKF Bearing Assessment kit:

SKF Machine Condition Advisor CMAS 100-SL

The SKF Machine Condition Advisor simultaneously measures machine vibration signals and temperature to indicate machine health and bearing condition.

SKF Infrared Thermometer CMSS 3000-SL

The heavy duty SKF Infrared Thermometer is a dual laser sighted, non-contact instrument for long range application.

For additional information on the instruments included in the kit, please refer to the previous, respective sections. For technical details on the SKF OilCheck TMEH1, please see the following.

SKF OilCheck TMEH1

The SKF OilCheck indicates the degradation and contamination level of oil, and detects increased mechanical wear and loss of the oil's lubricating properties.

- Handheld and user friendly
- Numerical readout to facilitate trending
- Shows changes in oil condition affected by:
 - Water content
 - Fuel contamination
 - Metallic content
 - Oxidation

The usual contamination found in oils is caused by oxidation and acid build up, which occur during normal machinery operation and typically show up as a gradual increase in the oil's "dielectric constant" readings over a period of time. In addition, excessive wear or mechanical failure may cause other contaminants to occur (i.e., dirt, soot, fuel, water, antifreeze, metal particles, etc.). These contaminants also cause an increase in the oil's dielectric constant.

The SKF OilCheck detects and measures change in an oil's dielectric constant by comparing measurements obtained from new and used oil samples. Measuring and trending changes to an oil's dielectric constant level provides information that helps optimize intervals between oil changes, and helps detect increased mechanical wear and loss of the oil's lubricating properties.

Technical Data

- Suitable oil types: Mineral and synthetic oils
- Repeatability: Better than 5%
- Readout: Green/Red grading, numerical value (0 to 100)
- Battery: 9 V Alkaline IEC 6LR61
- Battery lifetime: > 150 hours or 3 000 tests



- Dimensions:
 - Width: 95 mm (3.7 in.)
 - Height: 250 mm (9.8 in.)
 - Depth: 32 mm (1.3 in.)

Note:

The SKF OilCheck is not an analytical instrument. It is an instrument to detect changes in the oil condition only. The visual and numerical readouts provide a guide and enable trending of the comparative readings of a good oil to a used oil of the same type and brand.

Carrying case

The instruments are packaged in a light, durable, aluminium carrying case for industrial environment.

- Weight: 2,6 kg (5.7 lb.) case only
- Dimensions:
 - Length: 450 mm (18 in.)
 - Width: 330 mm (13 in.)
 - Depth: 150 mm (6 in.)
- Color: Powder coated (blue)

Ordering information

SKF Bearing Assessment kit [CMAK 300-SL] includes:

- SKF Machine Condition Advisor [CMAS 100-SL]
- SKF Infrared Thermometer [CMSS 3000-SL]
- SKF OilCheck [TMEH1]

SKF Machine Condition Advisor



SKF Infrared Thermometer



SKF OilCheck TMEH1



Carrying case



For additional information on the instruments included in the kit, please refer to the previous, respective sections.

SKF Electric Motor Assessment kit

CMAK 200-SL

For evaluation of electric motor bearings and general machine health

A fitting bundle of two measurement devices for electric motors and other industrial assets, the SKF Electric Motor Assessment kit makes the evaluation of electric motor bearings and general machine health simple.

Features

- Inspect and assess electric motor machine condition
- Measures:
 - Overall machine health
 - Bearing condition
- Safely detect electrical discharges in electric motors
- Ideal for novice and expert users

Multi-parameter measurements for electric motors

SKF Machine Condition Advisor CMAS 100-SL

The SKF Machine Condition Advisor (MCA) simultaneously measures machine vibration signals, specifically velocity, enveloped acceleration and temperature to indicate machine health and bearing condition.

For additional information on this instrument included in the kit, please refer to the previous, respective section.

SKF Electric Discharge Detector Pen TKED 1

The SKF Electric Discharge Detector Pen (EDD Pen) is a simple to use, handheld instrument that provides a unique, reliable and safe way to detect electrical discharges in electric motor bearings.

Electrical discharges are a result of motor shaft voltages discharging to earth through the bearing, causing electrical erosion, lubricant degradation and ultimately bearing failure.



Electric motors are more vulnerable to suffer electrical erosion in bearings when controlled by a variable frequency drive. When incorporated in a predictive maintenance program, the EDD Pen can help detect bearings that are more susceptible to failure, and can help to significantly prevent unplanned machine downtime.

- Unique remote solution allows operation at a distance from the motors, which protects the user from touching machinery in motion
- No special training required
- Capable of detecting electrical discharges on a time base of 10 seconds, 30 seconds or indefinite
- LED backlit screen allows use in low light environments
- IP 55 can be used in most industrial environments

Specifications

- Power supply: 4,5 V, 3 × standard AAA batteries (LR03, AM4)
- Time control:
 - Presets: 10 or 30 seconds
 - Default: Infinite
- Operational temperature: 0 to 50 °C (30 to 120 °F)
- Storage temperature: -20 to +70 °C (-5 to +160 °F)
- Ingress protection level: IP 55
- Display – LCD counter range: 0 to 99 999 discharges
- User selectable backlight and low battery warning
- Dimensions:
 - Length: 203,2 mm (8.0 in.)
 - Width: 48,3 mm (1.9 in.)
 - Depth: 20,3 mm (0.8 in.)
- Weight: 105 g (3.7 oz.)

SKF Machine Condition Advisor



SKF EDD pen



Since the 1990's, the use of variable-frequency drives (VFDs) to control alternating current (AC) motors has become very common, as they can save energy. However, the drawback of using VFDs is the fact that electrical motors are more vulnerable to suffer from electrical erosion in the bearings caused by electrical discharge currents. Electrical erosion can cause bearings to fail very prematurely, causing motor failure and unplanned downtime.

Until now there has not been an easy, cost effective method to detect electrical discharge currents in electric motor bearings. Thanks to the EDD Pen, this is now possible. Operating with only two buttons, the EDD Pen allows everybody to detect electrical discharge currents remotely in a safe way.

Unlike other traditional methods, the electrical discharge currents can be directly detected rather than measuring the effects in later stages when damage has already occurred.

When incorporated into a predictive maintenance program, the EDD Pen can significantly prevent unplanned machine downtime.



Carrying case

The instruments are packaged in a durable nylon carrying case.



- Weight: 113 g (4 oz.) case only
- Dimensions:
 - Length: 279 mm (11.0 in.)
 - Width: 229 mm (9.0 in.)
 - Depth: 64 mm (2.5 in.)
- Color: Black

Ordering information

- SKF Electric Motor Assessment kit CMAK 200-SL includes:
 - SKF Machine Condition Advisor [CMAS 100-SL]
 - SKF Electrical Discharge Detector Pen [TKED1]
 - Black nylon carrying case



Lubricant degradation caused by electrical discharge currents.

SKF Wireless MicroVibe

CMVL 4000-EN

Safe solution to portable data collection and analysis

The SKF Wireless MicroVibe in conjunction with an android tablet or smart phone provides the functionality of a portable data collector and analyzer.

This versatile and easy-to-use wireless tool identifies problems and assesses machine condition safely, quickly and easily.

Features

- Reliable and fast wireless data collection (WiFi) from a safe distance
- Low cost, compact and lightweight
- Expert judgment criteria based on ISO vibration severity standard and SKF bearing condition evaluation
- FFT spectrum analysis enables user to pinpoint problems like unbalance, misalignment, bearing, rubs, etc.
- Multi-point automation for faster data collection with standard vibration measurements
- Envelope acceleration, acceleration, velocity and displacement in both FFT spectrum and time waveform displays
- Transfer machinery vibration data to a computer for trending and further analysis to the Data Management Software



Power without complexity

A handy “quick-check” solution, based on the universal Android platform, SKF Wireless MicroVibe is simple to use. Built-in automatic functions virtually eliminate setup, while analytical displays and automatic judgment of machine vibration readings help users identify machine problems on the spot!

An advanced instrument for simplified vibration assessment.



Multi-point automation saves time and improves reliability

The SKF Wireless MicroVibe collects and displays overall vibration readings and automatically provides expert judgment of the measured velocity and overall enveloped acceleration levels, enabling immediate, accurate and reliable assessment of machine or bearing condition.

Automatically collect the most useful measurements for vibration analysis – acceleration, velocity, displacement and enveloped acceleration – simultaneously. SKF's multi-point automation saves time and enhances the power, accuracy and overall reliability of your decision making – giving you the information all in one view.



FFT spectrum analysis capabilities

With pre-set measurements and user selectable FFT resolution up to 12 800 lines, selectable Fmax, and a 90 dB dynamic range, the SKF Wireless MicroVibe has what it takes to help you easily pinpoint impending machine problems. Cursor position readout with display zoom optimizes your analysis power. In addition, it automatically tabulates and displays the highest vibration peaks from a spectrum, making it easy to quickly identify signals indicative of specific machine problems, like misalignment, imbalance or bearing faults.

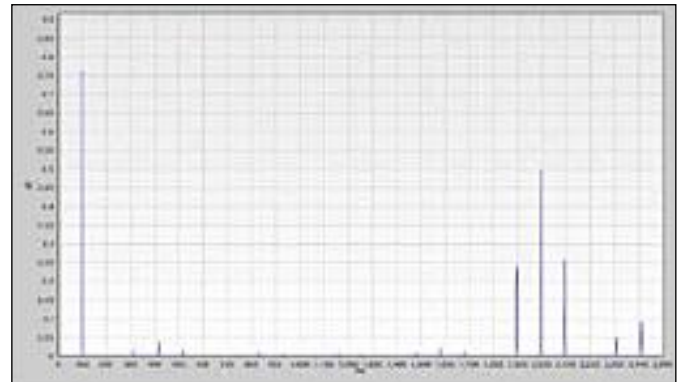

Time waveform displays

Measure and store time waveform data with the capability to select measurement type and duration. Time waveform displays are available for acceleration, velocity, displacement or enveloped acceleration measurements.

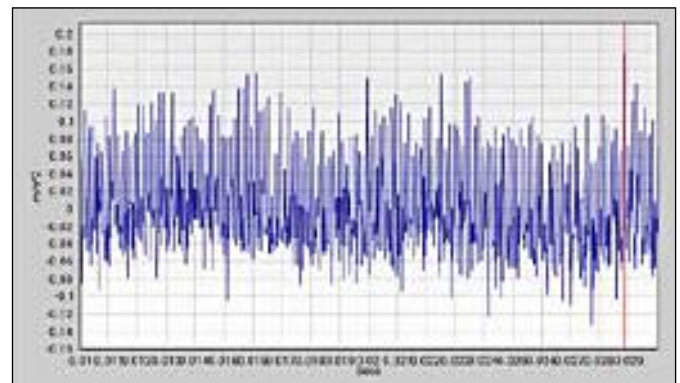

Store and recall measurements for trending and analysis

The data storage capacity is dependent upon the available memory of the android device used. Dedicated devices can store thousands of overall vibration signals, FFT spectrums and records of time waveform data for later recall. A search feature quickly retrieves specific collected measurement, and a "repeat measurement" feature let's you recall and repeat any measurement for more focused analysis or trending of a potential problem. Finally, a "recall data storage" list helps you keep track of and reference all collected data.

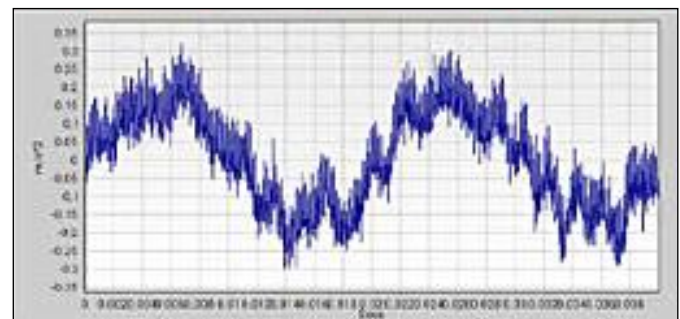

Data management and software for your desktop computer

The SKF Wireless MicroVibe offers added functionality, including a software program for Windows 7 to extract, save, edit and display collected data. It is ideal for small route data collection.

Data may be uploaded to your desktop computer for further analysis and trending using the data management software. Once uploaded, vibration data, overall trends and spectra can be stored, trended, graphically displayed and even exported to Microsoft Excel.

SKF's data management software

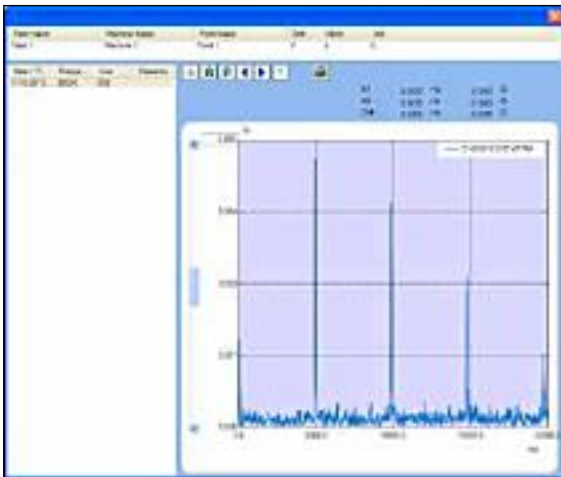

FFT spectrum analysis plot.

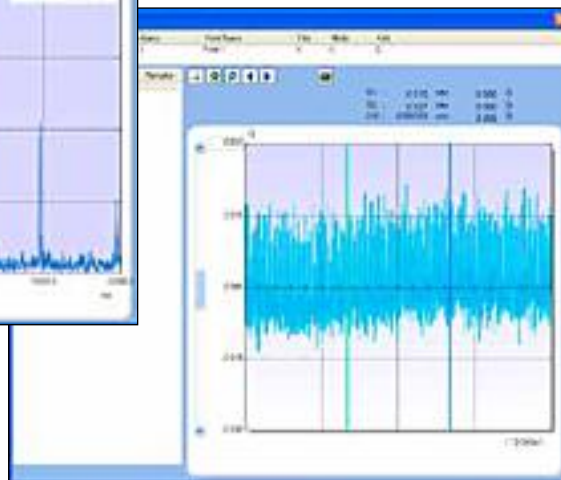

Waveform plot.

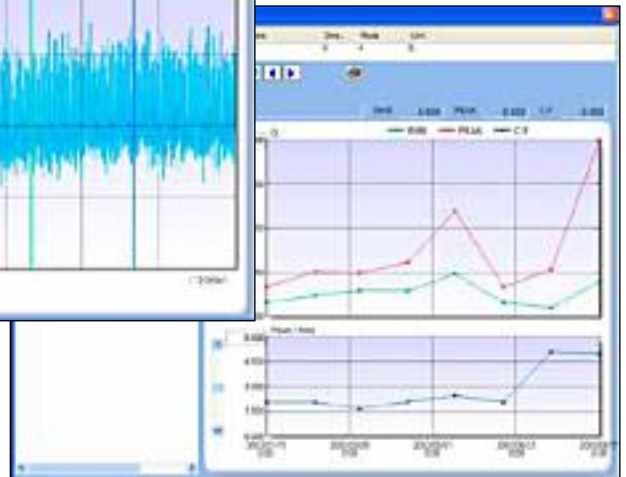

Trending and analysis plot.

Specifications

Interface

- WiFi 802.11b/g, 128-bit WEP, WPA/WPA2 security
- Wireless communication mode: Infrastructure mode (point-to-point)

Power

- Power supply: Two (2) each "AAA" NiMH rechargeable batteries, 1 100 mAh
- Power consumption: 150 mA (while taking data and use of WiFi)
- Battery life with one charge: 5 hours
- Universal charger
 - Input: 100 to 240 V 50/60 Hz 0.5A
 - Output: 5 V at 2.1 A

Environmental

- Weight: 145 g (5.1 oz.)
- Dimensions:
 - Depth: 42 mm (1.62 in.)
 - Width: 40 mm (1.57 in.)
 - Height: 89 mm (3.50 in.)
- Operating temperature: 5 to 50 °C (40 to 120 °F), driven by the battery
- Humidity: 30 to 90%, non-condensing

Sensor

- Piezoelectric (accelerometer)
- Sensitivity: 20 mV/g
- Sampling frequency: 76.8 kHz maximum
- A/D resolution: 16 bit

Measurement

- Acceleration range: 50 g

- Frequency range:
 - Acceleration (A): 10 Hz to 30 kHz
 - Velocity (V): 10 Hz to 1 kHz
 - Displacement (D): 10 to 150 Hz
 - Enveloped Acceleration (E1): 5 to 100 Hz
 - Enveloped Acceleration (E2): 50 Hz to 1 kHz
 - Enveloped Acceleration (E3): 500 Hz to 10 kHz with Fmax of 5 kHz and 10 kHz
 - Enveloped Acceleration (E3)*: 500 Hz to 5 kHz with Fmax of 1.0 kHz
 - Enveloped Acceleration (E4)*: 5 to 20 kHz

* These frequencies vary from the standard filterbands used in the SKF Micrologs and SKF Multilog IMx.

- Sampling frequency:
 - A, E3, E4: 76,8 kHz
 - E1, E2, V, D: 38,4 kHz
- Aliasing frequency:
 - A, E3, E4: 20 kHz
 - E1, E2, V, D: 2 kHz
- Range (x100/20/5/1):
 - A: 0 to 1/5/20/100 g
 - E1, E2, E3, E4: 0 to 1/5/20/100 gE

Signal processing

- Velocity (x100/20/5/1 range): 0 to 10/50/200/1 000 mm/s
- Displacement (x100/20/5/1 range): 0 to 50/250/1 000/5 000 µm
- FFT:
 - Lines of resolution: up to 12 800
 - Averaging: Stable (linear), exponential, peak hold 1/2/4/8 times
- Window: Hanning, Rectangular, Flat Top

Dimensions

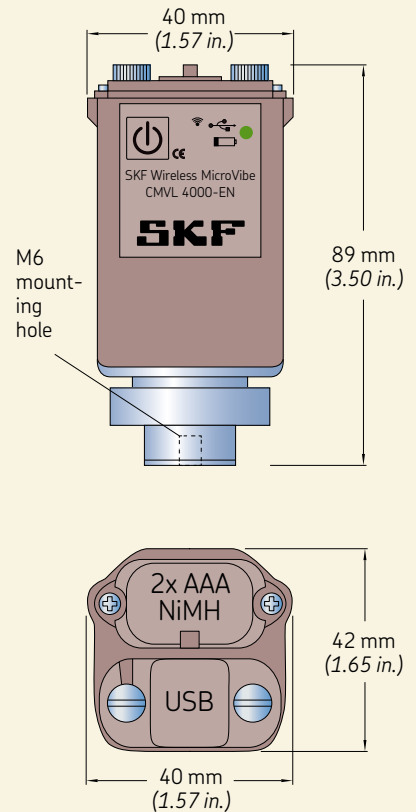

Recommended Android Tablets

Highly recommended is the Nexus 7 series, with 7 inch LCD display.

The SKF Wireless MicroVibe application is verified to work with the following Android devices as shown in **Table 1**. (Please visit the device compatibility matrix in skf.com/cm [Tablets] for current devices).

Android Smartphones do communicate to the SKF Wireless MicroVibe sensor module. Taking vibration data is possible; however uploading the data into the data management software is not assured.



Table 1

Devices verified to work with the SKF Wireless MicroVibe

Name	OS version	Supplier	Note
IdeaPad Tablet A1	2.3	Lenovo	7-inch
BizPad JT-H580VT	3.2	Panasonic	7-inch for business use; USB host function is available
Regza Tablet AT350/35D	3.2	Toshiba	7-inch
Nexus 7	4.2.2 and 4.2.3	ASUS	7-inch
HTC One (M7)	4.1.2	HTC	4.7-inch
CT704	4.0.4	iDeaUSA	7-inch

Ordering information

SKF Wireless MicroVibe kit (WITHOUT Tablet*)

- **CMVL 4000-EN** SKF Wireless MicroVibe kit
 - Sensor module, one (1) each [CMVL 4000]
 - Probe (Stinger), one (1) each [CMAC 4020]
 - USB cable, sensor module to USB, one (1) each [CMAC 4015]
 - Universal USB power supply with four adapters, one (1) each [CMAC 4010]
 - Two bar magnet, 18.1 kg (40 lbs.), one (1) each [CMAC 4025]
 - Battery (rechargeable), standard NiMH (AAA size), two (2) each, [CMAC 4005]
 - CD: Data management software, mobile application, SKF User Manual, one (1) each [CMAC 4060]

*NOTE: Necessary Android Tablets and Smartphones are not included and are not offered by SKF.

Optional accessories

- Carrying case, with customizable form [CMAC 4035]



SKF Wireless MicroVibe CMVL 4000-EN turn-key package.



Carrying case dimensions
(length × width × height):
350 × 110 × 245 mm
(13.8 × 4.3 × 9.6 in.).

NOTE: Necessary Android Tablets
are not included and are
not offered by SKF.

SKF Wireless MicroVibe CMAC 4035 carrying case with customizable foam.

SKF Machine Condition Detector Pro IS

CMVL 3600-IS

Intrinsic Safety (IS) rated

The SKF Machine Condition Detector Pro IS (MCD Pro IS) is a rugged, handheld analysis tool that captures and displays temperature, velocity and enveloped acceleration (vibration) and alarms.

The SKF MCD Pro IS is certified Intrinsically Safe (IS) for use in hazardous environments that require either a Zone I or Class I, Division I rating.

The MCD Pro IS collects and displays velocity, acceleration enveloping and temperature data with general alarm capabilities.



ATEX and North America hazardous conditions approvals – the SKF Machine Condition Detector Pro IS provides for velocity, enveloped acceleration and temperature monitoring with general alarm capabilities.

Features

- Multi-parameter measurements
- Simple machine monitoring
- Alarm capabilities for enhanced user confidence

Go/No Go machine monitoring

The MCD Pro IS is designed to provide a straightforward approach to machinery monitoring. The instrument's sensor affixes to a machine point via a SKF MARLIN QuickConnect (MQC) stud or magnetic base for automatic collection of vibration and temperature data. Green, yellow and red LEDs provide easy to interpret indications of machine status, so operations or maintenance personnel can quickly identify the need for more in-depth analysis on a particular machine.

Multi-parameter monitoring capabilities

The MCD Pro IS operates as a stand-alone device or as an integral component of the complete SKF MARLIN System.

By pairing the MCD Pro IS with the SKF Microlog Inspector / SKF MARLIN handheld device, important machinery and process information may be stored for trending review. Data can also be transferred with the SKF system from the MCD Pro IS to @ptitude Inspector software for further detailed analysis.

Vibration monitoring

When performing measurements, the MCD Pro IS's sensor input signal is processed to produce two vibration measurements for each measurement POINT. Velocity vibration identifies phenomena that are observable in the low to mid frequency range and indicates such structural problems as misalignment, unbalance, mechanical looseness and more.

Events that occur in the higher frequency ranges, such as bearing and gear problems, can also be detected by the MCD Pro IS with its "acceleration enveloping" capability, a signal processing technique that focuses on enhancing the repetitious vibration signals that characterize such problems.

Temperature

Temperature measurements enhance the "early warning" benefit of the instrument by offering a useful indication of mechanical condition or the load applied to a specific component, since as a bearing or its lubrication fails, friction causes its temperature to rise.

General alarm capabilities

When used as a stand-alone tool, the MCD Pro IS may be easily programmed for six alarm settings, which include the “alert” and “danger” levels for each of the three measurements.

When measurements are taken, current measured values are automatically compared to six user-defined settings, and the MCD Pro IS’s alarm indicator and LEDs react appropriately. An “alert” condition provides the user with an early warning of impending problems for which immediate in-depth analysis should be performed. A “danger” alarm indicates that a problem has escalated to a point where actions must be made quickly to avoid a serious failure.

When used with the SKF Microlog Inspector / SKF MARLIN, data is logged for trending and percent change from last measurement and baseline data.

SKF MARLIN QuickConnect studs for quality, repeatable data collection



Specially designed mechanical and computerized studs enable users to collect consistent, accurate and repeatable data from each measurement point. Engineered to work exclusively with the MCD Pro IS, the MQC mechanical and computerized studs provide for a fast, quarter-turn connection that temporarily fastens the probe to a measurement point. This reduces the possibility of errors and inconsistencies often resulting from data collected by using varying methodologies.

Specifications

Measurements

- Vibration pickup: Integrated piezoelectric acceleration (ceramic, shear type)
- Measurement range:
 - Velocity: 0,3 to 55,0 mm/s (RMS) (0.02 to 3.00 in./s (Eq. Peak)), meets ISO Standard 10861-3
 - Enveloped acceleration: 0,3 to 20,0 gE
 - Temperature: 0 to 100 °C (30 to 210 °F)

- Frequency range:
 - Overall velocity: 10 Hz to 1 kHz (tolerances measured within the frequency range are in accordance with ISO 2954)
 - Acceleration enveloping band 3: 500 Hz to 10 kHz

Power

- Main power: Two 1,5 V alkaline AA batteries
- Battery lifetime: 30 hours
- Backup battery: One 3 V BR1225 Lithium-ion battery
- Auto off: Two minute countdown on last operation

User environment

- Operating temperature:
 - Ordinary locations: –20 to +60 °C (–5 to +140 °F)
 - Hazardous locations: –20 to +40 °C (–5 to +105 °F)
- Storage temperature: –35 to +70 °C (–30 to +160 °F)
- Humidity: 5 to 95% non-condensing

Hazardous area ratings

- Intrinsic Safety (IS):
 - ATEX: II1G EEx ia IIC T4 (Ta = –20 to +40 °C (–5 to +105 °F))
 - Class I, Division 1, Groups A, B, C, D T3A (USA, Canada)

Physical characteristics

- Case: Water and dust resistant (IP 65)
- Drop test: 1,8 m (6 ft.) on multiple axes
- Dimensions:
 - Length: 190,5 mm (7.50 in.)
 - Width: 43,2 mm (1.70 in.)
 - Depth: 41,4 mm (1.63 in.)
- Weight: 431 g (0.95 lb.) with battery, 635 g (1.4 lb.) with temperature magnet probe tip
- Display viewing area: 55,0 × 17,8 mm (2.17 × 0.70 in.)
- Communications port type: Micro D RS-232

Quick connect interface

- Receptacle: 1/4 turn, 5/8–24 two lead thread with contact

Accessories

- CMSS 26xx series: SKF MARLIN QuickConnect studs



Need to boost your plant's availability and reliability?

Start with operator driven reliability from SKF

For today's power plants, optimizing output in the face of rising operating costs, reduced manpower and stringent regulations is a constant challenge. By enabling operators to take the lead in monitoring and maintaining equipment, the proven operator driven reliability (ODR) program from SKF is helping plants meet this challenge.

Why operator driven reliability?

Because of their proximity to equipment, operators are usually the first to detect even the smallest changes in process conditions and machinery health, including leaks, abnormal readings, excessive heat, vibration or pressure.

In a successful ODR program, operators perform process parameter inspections, record and communicate observations on machine performance, and make minor adjustments. Using technology to automate these tasks facilitates consistency, accuracy and plant-wide information sharing, all of which can enhance your production and maintenance strategies.

With ODR, operators become an integral part of an overall reliability-based asset management strategy that can result in increased productivity and reduced unplanned downtime.

Why choose SKF?

SKF knowledge engineering enables a comprehensive, single source ODR solution. Featuring hand held monitoring devices, sensors and software, SKF's ODR system components work together seamlessly and integrate with a plant's computerized maintenance management and/or decision support system.

SKF has the experience and expertise to tailor an operator driven reliability program to meet your facility's unique goals and help implement sustainable, continuous improvement.

Ordering information

SKF Machine Condition Detector MCD Pro IS CMVL 3600-IS-K-01-C Kit

Each **CMVL 3600-IS-K-01-C** kit consists of the following items:

- SKF Machine Condition Detector Pro IS probe [CMVL 3600-IS]
- Temperature magnet probe tip for SKF Machine Condition Detector Pro IS probe [CMAC 3610]
- AA Alkaline batteries, two each
- SKF Machine Condition Detector Pro IS setup key [CMAC 3620]
- SKF Machine Condition Detector Pro IS padded carrying case [31736700]
- SKF Machine Condition Detector Pro IS user manual [CMVL 3600M-SL]
- SKF Machine Condition Detector Pro IS quick start card [CMVL 3600-QS]
- Vibration severity card

SKF MARLIN quick connect and mounting accessories

- SKF MARLIN quick connect interface receptacle, 1/4 turn, 5/8-24 two lead thread with contact
- SKF MARLIN quick connect mechanical M8 × 1,25 mounting thread – three studs per package [CMSS 2600-3]
- SKF MARLIN quick connect mechanical 1/4-28 mounting thread – three studs per package [CMSS 2610-3]
- SKF MARLIN quick connect computerized M8 × 1,25 mounting thread – three studs per package [CMSS 2601-3]
- SKF MARLIN quick connect computerized 1/4-28 mounting thread – three studs per package [CMSS 2611-3]
- Toolkit for spot face 1/4-28 [CMAC 9600-01]
- Toolkit for spot face M8 × 1,25 [CMAC 9600-02]
- Drill bit for 1/4-28 kit [CMAC 9600-03]
- Tap for 1/4-28 kit [CMAC 9600-04]
- Pilot for 1/4-28 kit [CMAC 9600-05]
- Drill bit for M8 × 1,25 kit [CMAC 9600-06]
- Tap for M8 × 1,25 kit [CMAC 9600-07]
- Pilot for M8 × 1,25 kit [CMAC 9600-08]
- End mill or counter bore for either kit [CMAC 9600-09]
- Toolkit for spot face M6 × 1,25 [CMAC 9600-10]



SKF Microlog Inspector systems (left to right): CMTM 6700 series I-Pro, CMTM 5700 series S-Pro, CMTM 5660 S-Pro and the SKF Machine Condition Detector Pro IS.

Optional accessories

- Cable, SKF MARLIN I-Pro CMDM 6500 series to SKF Machine Condition Detector Pro IS (Requires CMAC 6142 snap-on adapter, sold separately) [CMAC 6141]
- Snap-on adapter, SKF MARLIN I-Pro [CMAC 6142]
- Cable, SKF MARLIN S-Pro CMDM 5460 to SKF Machine Condition Detector (Requires CMAC 6115 adapter) [CMAC 6109]
- Adapter, SKF MARLIN S-Pro [CMAC 6115]
- SKF Machine Condition Detector Pro IS setup key [CMAC 3620]
- Temperature magnet for SKF Machine Condition Detector Pro IS probe [CMAC 3610]
- Probe tip replacement kit for temperature magnet for SKF Machine Condition Detector Pro IS [CMAC 3630]
- Magnetic probe tip for SKF Machine Condition Detector Pro IS [CMAC 3611]
- Stinger probe 10 cm (4 in.) [CMSS 60139-04]
- 1/4-28 SKF MARLIN quick connect for stinger interface [CMSS 2610-1]
- SKF Machine Condition Detector Pro IS quick start card [CMVL 3600-QS]
- SKF Machine Condition Detector Pro IS user manual [CMVL 3600M-SL]



CMAC 3600-IS MCD Pro IS probe



CMAC 3625 carrying case

SKF MARLIN data manager

The SKF Machine Condition Detector Pro IS can be used in non-hazardous areas with the SKF MARLIN CMDM 6500 and CMDM 5400 series.

For additional information on the SKF MARLIN data managers, please refer to SKF publication number SR/P2 10272 EN or contact your local SKF Sales Representative.

CMAC 3610 temperature magnet probe tip



CMAC 3620 setup key



Protective cover



Vibration severity card (front and back)

Envelope Severity	Shaft Diameter and Speed		
	Diameter Between 10 and 100 mm (3/8 and 4 in.) 100 and 1500 rpm	Diameter Between 10 and 100 mm (3/8 and 4 in.) 150 and 2000 rpm	Diameter Between 20 and 100 mm (3/4 and 4 in.) 150 and 2000 rpm
W	Unacceptable (Danger)	Unacceptable (Danger)	Unacceptable (Danger)
X	Unacceptable (Alarm)	Unacceptable (Alarm)	Unacceptable (Alarm)
Y	Satisfactory	Satisfactory	Satisfactory
Z	Good	Good	Good

Velocity Severity	Machinery Group 2 Medium Machines	Machinery Group 1 Large Machines	
	Rated Power: 55 kW to 300 kW Electric Machines with Shaft height 250 to 215 mm (10 to 8.5 in.)	Rated Power: >300 kW Electric Machines with Shaft height >215 mm (8.5 to 8.5 in.)	
W	Unacceptable (Danger)	Unacceptable (Danger)	Unacceptable (Danger)
X	Unacceptable (Alarm)	Unacceptable (Alarm)	Unacceptable (Alarm)
Y	Satisfactory	Satisfactory	Satisfactory
Z	Good	Good	Good

Loop-powered vibration transmitters series

CMSS 420VT / CMCP 420VT-T

Simply, the most economical approach to preventive maintenance

Have somebody look after your rotating machinery, including pumps, motors, fans, blowers, compressors and other machinery for too much vibration. The SKF loop-powered vibration transmitter works around the clock, seven days a week.

Features

- Solid-state reliability
- Integral sensor
- Standard 4 to 20 mA output
- Dynamic signal output for portable analyzers
- CE approved
- Approved Class 1, Division 2, Groups B, C, D for United States and Canada

Description

The CMSS 420 series are solid state, loop-powered vibration transmitters. They provide a 4 to 20 mA output that is proportional to overall vibration in terms of velocity. The series of CMSS 420 continuously monitor machinery health and transmit directly into a PLC or DCS for trending, alarm and machine shutdown. In addition, the CMSS 420VT provides access to the dynamic transducer output. The buffered output is available for temporary connection of portable analyzers for detailed machine fault analysis.

In addition, the CMCP 420VT-T provides a second 4 to 20 mA output related to temperature.

Simple installation

Simply mount the CMSS 420VT into a 1/4-28 or M8 tapped hole in the bearing housing or machine case (NPT mounting adapters are available, part number CMSS 203), connect two wires into a 4 to 20 mA loop, and you are ready to interface with a PLC or DCS. Electrical conduit may be connected directly to the top 3/4 in. NPT fitting (NPT mounting adapters are available, part number CMSS 203).



Hazardous Location Safety
E112798
UL1604, CSA C22.2 No 213
Cl 1, Div 2, Grp B,C,D
24 VDC, 23 mA Max



Specifications

CMSS 420VT velocity and dynamic signal output

Dynamic

- Output: 4 to 20 mA proportional to full scale velocity
- Accuracy: $\pm 5\%$ of full-scale
- Frequency response: 2 to 2 000 Hz
- Frequency response accuracy:
 - -3 dB: 2 Hz to 2 kHz
 - 10%: 10 Hz to 1 kHz
 - 5%: 15 to 750 Hz
- Buffered output: Acceleration, 100 mV/g

CMCP 420VT-T velocity and temperature output

Dynamic

- Output 1: 4 to 20 mA proportional to full scale velocity
- Velocity accuracy: $\pm 5\%$ of full-scale
- Frequency response: 2 to 2 000 Hz
- Frequency response accuracy:
 - -3 dB: 2 Hz to 2 kHz
 - 10%: 10 Hz to 1 kHz
 - 5%: 15 to 750 Hz
- Output 2: 4 to 20 mA proportional to full scale temperature
 - From 0 to 100 °C (30 to 210 °F)
- Temperature accuracy: 2,5 °C at 85 °C (4.5 °F at 185 °F)

CMSS 420VT and CMCP 420VT-T

Environmental

- Operating temperature: -20 to +80 °C (-5 to +175 °F)
- Sealed: Epoxy encapsulated
- Case material: Stainless steel 316L
- Mounting: Stud mounted
- Weight (without display): 227 g (8 oz.)

Regulatory approval

CE Mark: SKF loop-powered vibration transmitter CMSS 420VT and displays CMSS 420LCD and CMSS 420LED

Hazardous area ratings

- Suitable for use in Class I, Division 2, Groups B, C, D (United States and Canada)

Electrical ratings

- 22 to 36 V DC, 4 to 23 mA, provided from an external DC source rated 36 V DC maximum, 23 mA maximum. The CMSS 420VT is suitable for use in Class I, Division 2, Groups B, C, D.
- Maximum load: Up to 500 Ω resistive at 24 V DC and no display (see note – maximum load resistance calculations for specific requirements)
- Grounding: Case isolatedΩ

Ordering information

- **CMSS 420VT-1**
 - 25,4 mm/s (0 to 1 in./s) RMS, includes 1/4-28 and M8 mounting studs
- **CMSS 420VT-2**
 - 50,8 mm/s (0 to 2 in./s) RMS, includes 1/4-28 and M8 mounting studs
- **CMCP 420VT-T1**
 - 25,4 mm/s (0 to 1 in./s) RMS, 0 to 100 °C (30 to 210 °F), includes 1/4-28 and M8 mounting studs
- **CMCP 420VT-T2**
 - 50,8 mm/s (0 to 2 in./s) RMS, 0 to 100 °C (30 to 210 °F), includes 1/4-28 and M8 mounting studs

Optional display

Light Emitting Diode display (LED)

- **CMSS 420LED-01**
 - 0 to 1 in./s
- **CMSS 420LED-02**
 - 0 to 2 in./s
- **CMSS 420LED-51**
 - 25,4 mm/s
- **CMSS 420LED-52**
 - 50,8 mm/s

Liquid Crystal Display (LCD)

- **CMSS 420LCD-01**
 - 0 to 1 in./s
- **CMSS 420LCD-02**
 - 0 to 2 in./s
- **CMSS 420LCD-51**
 - 25,4 mm/s
- **CMSS 420LCD-52**
 - 50,8 mm/s

Note: Maximum load resistance calculations:

DC supply voltage range: 22 to 36 V DC

$$R_L \text{ max} = \frac{V_s - 14 - V_d}{0,02}$$

R_L = Load resistance

V_s = DC supply voltage

V_d = Display voltage: 5,0 V DC for LED, 2,0 V DC for LCD, 0,0 V DC for no display

The recommended Load Resistance (R_L) for most installations is: 100 or 250 Ω at $V_s = 24$ V DC, with or without an LED/LCD display.

Accessories

- **CMSS 420LCD/CMSS 420LED** display retrofit (requires transmitter)
 - LCD displays actual vibration levels in velocity on a Liquid Crystal Display. LED displays actual vibration levels in velocity on a Light Emitting Diode display. The displays are shipped loose, and it is a simple installation. Includes a BNC connector that provides access to the raw acceleration signal for the CMSS 420VT.
- **CMSS 420BNC** BNC adapter retrofit
 - 90 degree 3/4 in. NPT conduit elbow with a BNC connector to access the raw acceleration signal. This is useful for connecting the CMSS 420VT to the portable data collectors.
- **CMSS 420EL** 90 degree 3/4 in. by 3/4 in. NPT elbow
 - Useful for connecting CMSS 420VT to hard or flexible conduit. When used with the CMSS 420WF, provides a simple weatherproof exit for the instrument wire.
- **CMSS 420WF** 3/4 in. NPT weatherproof cable fitting
 - When used with the CMSS 420EL, provides a simple weatherproof exit for the instrument wire.
- **CMSS 203** pipe thread accelerometer mounting adapters
 - They are provided in several NPT sizes to accommodate the most common plugs found on most machinery. The adapters have a 1/4-28 threaded hole to mate with the CMSS 520 VT and most common accelerometers and vibration transmitters.
 - **CMSS 203-01** 1/2 in. (NPT) National pipe tapered thread
 - **CMSS 203-02** 3/4 in. (NPT) National pipe tapered thread
 - **CMSS 203-03** 3/8 in. (NPT) National pipe tapered thread
 - **CMSS 203-04** 1/4 in. (NPT) National pipe tapered thread



CMSS 420LCD / CMSS 420LED display retrofit



CMSS 420EL NPT elbow



CMSS 203 pipe thread accelerometer mounting adapter



CMSS 420BNC BNC adapter retrofit



CMSS 420WF NPT weatherproof cable fitting

General purpose industrial accelerometer

CMSS 2100

Incorporating the latest in technology to meet the demanding CE, EMC and low noise level requirements



Using detailed knowledge acquired from many years of supplying high quality sensors to a broad spectrum of industry users, SKF offers rugged accelerometers designed for the pulp and paper, petrochemical, steel, mining, construction, metal working and machine tool industries.

Features

- For use with the SKF junction boxes, on-line systems, protection systems and the portable data collection instruments
- Rugged, economical and all around general purpose sensor
- Sensitivity, 100 mV/g to optimize use in multiple applications
- Exceptional bias voltage (BV) stability at elevated temperatures
- Designed for exceptional low noise level for low elevated temperatures
- Meets stringent CE, EMC requirements
- Smaller profile industrial accelerometers
- Two mounting studs (1/4-28 and M8 x 1,25) provided
- Corrosion resistant and hermetically sealed for humidity areas
- Reverse polarity wiring protection

Specifications

Specifications conform to ISA-RP-37.2 (1 to 64) and are typical values referenced at 25 °C (75 °F), 24 V DC supply, 4 mA constant current and 100 Hz.

Dynamic

- Sensitivity: 100 mV/g
- Sensitivity precision: ±5% at 25 °C (75 °F)
- Acceleration range: 80 g peak
- Amplitude linearity: ≤ 1%, up to full scale
- Frequency range:
 - ±5%; 3,0 to 5 000 Hz
 - ±10%; 1,0 to 9 000 Hz
 - ±3 dB; 0,5 to 14 000 Hz
- Resonance frequency: Mounted, nominal 30 kHz
- Transverse sensitivity: ≤ 5% of axial



Electrical

- Power requirements:
 - Voltage source: +24 V DC nominal, 18 to 30 V DC
 - Constant current diode: 2 to 10 mA DC, recommended 4 mA
- Electrical noise: 2,0 Hz; 20 µg/√Hz
- Output impedance: < 100 Ω
- Bias output voltage: 12 V DC
- Grounding: Case isolated, internal shielding

Environmental

- Temperature range: –50 to +120 °C (–60 to +250 °F), operating temperature
- Vibration limits: 500 g peak
- Shock limit: 5 000 g peak
- Electromagnetic sensitivity, equivalent g, maximum: 70 µg/gauss
- Sealing: Hermetic
- Base strain sensitivity: 200 µg/microstrain
- CE: According to the generic immunity standard for Industrial Environment EN50082-2.
- Acceptance Criteria: The generated "false equivalent g level" under the above test conditions should be less than 2 mg peak to peak.

Physical

- Dimensions: See drawing
- Weight: 90 g (3.2 oz.)
- Case material: 316L stainless steel
- Mounting: Internal 1/4-28 thread; mounting studs provided: one 1/4-28 to 1/4-28 thread and one M8 × 1,25 thread
- Mounting torque: 2,9 Nm (24 in. lbs.)
- Connector:
 - Pin A: Signal/Power
 - Pin B: Common
- Mating connector: CMSS 3106F-10SL-4S or equivalent
- Recommended cable: Two conductor shielded, fluorine based polymer jacket, 100 pF/m (30 pF/ft.)

Ordering information

- **CMSS 2100** General purpose industrial accelerometer with top exit MIL-C-5015 two pin connector.
 - 1/4-28 and M8 mounting studs provided. Calibration sensitivity and nominal sensitivity is provided for each accelerometer package.

Dimensions

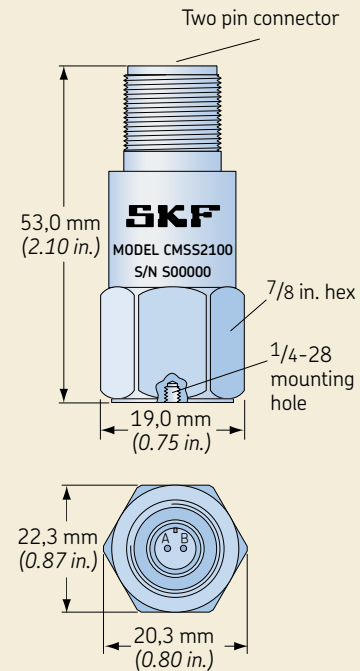

General purpose, low profile, side exit, industrial accelerometer

CMSS 2200 / CMSS 2200-M8



Accelerometers sense vibration commonly found in most industrial machinery. Applications for acceleration and velocity sensors include machinery health monitoring of motors, fans, pumps, gearboxes, blowers, machine tool spindles, compressors, chillers, rollers and mixers. Maintenance professionals use accelerometers for predictive maintenance to lower overall cost and increase machinery performance.

The CMSS 2200 / CMSS 2200-M8 with its side exit two pin connector offers a low profile for machinery with limited clearance. The sensor mounts in any orientation.

Features

- For use with the SKF junction boxes, on-line systems, protection systems and the portable data collection Instruments
- Rugged, economical and all around general purpose sensor
- Sensitivity, 100 mV/g to optimize use in multiple applications
- Exceptional bias voltage (BV) stability at elevated temperatures
- Designed for exceptional low noise level for low frequencies at elevated temperatures
- Meets stringent CE, EMC requirements
- Low profile for side industrial accelerometer with captive mounting bolts (1/4-28, M6 × 1.00 or M8 × 1,25) provided
- Corrosion resistant and hermetically sealed
- Reverse polarity wiring protection

Specifications

- Specifications conform to ISA-RP-37.2 (1 to 64) and are typical values referenced at 25 °C (75 °F), 24 V DC supply, 4 mA constant current and 100 Hz.

Environmental

- Temperature range: -50 to +120 °C (-60 to +250 °F), operating temperature
- Vibration limits: 500 g peak
- Shock limit: 5 000 g peak

- Electromagnetic sensitivity, equivalent g, maximum: 70 µg/gauss
- Sealing: Hermetic
- Base strain sensitivity: 200 µg/microstrain
- CE: According to the generic immunity standard for Industrial Environment EN50082-2
- Acceptance criteria: The generated "false equivalent g level" under the above test conditions should be less than 2 mg peak to peak.

Dynamic

- Sensitivity: 100 mV/g
- Sensitivity precision: ±10% at 25 °C (75 °F)
- Acceleration range: 80 g peak
- Amplitude linearity: 1%
- Frequency range:
 - ±10%; 1,0 to 5 000 Hz
 - ±3 dB; 0,7 to 10 000 Hz
- Resonance frequency: Mounted, minimum 22 kHz
- Transverse sensitivity: ≤ 5% of axial

Electrical

- Power requirements:
 - Voltage source: 18 to 30 V DC
 - Constant current diode: 2 to 10 mA DC, recommended 4 mA
- Electrical noise: 2,0 Hz; 20 µg/√Hz
- Output impedance: < 100 Ω
- Bias output voltage: 12 V DC
- Grounding: Case isolated, internal shielding

Physical

- Dimensions: See drawing
- Weight: 145 g (5.1 oz.)
- Case material: 316L stainless steel
- Mounting: Captive mounting bolts provided; one 1/4-28 thread and one M6 x 1,00 thread
- Mounting torque: 3,4 Nm (30 in. lbs.)
- Connector:
 - Pin A: Signal/Power
 - Pin B: Common
- Mating connector: CMSS 3106F-10SL-4S or equivalent
- Recommended cable: Two conductor shielded, fluorine based polymer jacket, 100 pF/m (30 pF/ft.)

Ordering information

- **CMSS 2200** General purpose low profile industrial accelerometer with side exit MIL-C-5015 two pin connector.
 - 1/4-28 and M6 mounting studs provided. Calibration sensitivity and nominal sensitivity is provided for each accelerometer package.
- **CMSS 2200-M8** General purpose low profile industrial accelerometer with side exit MIL-C-5015 two pin connector.
 - M8 mounting stud provided. Calibration sensitivity and nominal sensitivity is provided for each accelerometer package.

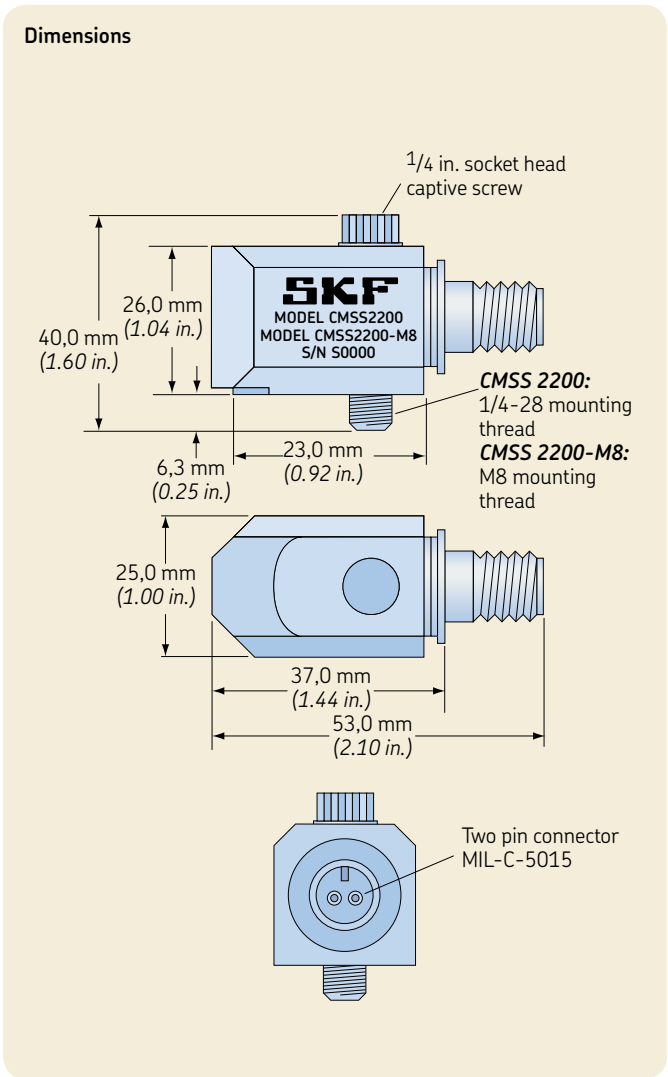

Vibration sensor cables

CMSS 93x series

Bulk cable

CMSS 932-SY/DY/SB and CMSS 933-SY

Twisted pair or triads cables, single or double shielded, yellow or blue jacket

SKF's CMSS 93X-XX cables are premium sensor cables providing superior performance in demanding environments.

CMSS 932 is a single or double shield, twisted pair cable with the conductors individually insulated with a fluorine based polymer, a braided shield with drain wire and an outer insulated jacket also made of a fluorine based polymer. Two insulated conductors are cabled together with one uninsulated drain wire and two glass cord fillers. The double shielded option adds an inner shield of aluminum polyester foil with drain wire.

The CMSS 933 has the same characteristics as the CMSS 932 cable, except the CMSS 933 is a three wire version for use with dual temperature and vibration sensors. This cable does not have a double shielded option.

There are two wire colors (jackets) available:

- Yellow: For high visibility in the often dusty and debris laden industrial environment
- Blue: For use in intrinsically safe circuits in the Oil/Gas and Hydrocarbon processing industries

Recommended uses

The single shield cable is recommended for use with sensors in normal industrial applications where these cable types have been previously used and installed.

The double shield cable is highly recommended for use with sensors in industrial installations where there is a high noise field, such as machine tools and power generating facilities. Double shielded versions include:

- Inner shield = Isolated
- Outer shield = Non-isolated

Specifications (all models)

Materials

- Conductor: Tin plated copper, 19 × 32 strands, size 20 AWG (American Wire Gauge)
- Insulation: Extruded FEP
- Drain wire: Tin plated copper, 7 × 32 strands, size 24 AWG
- Shield: 36 AWG tin plated copper braid
- Jacket: Extruded FEP

Two-wire cable assembly

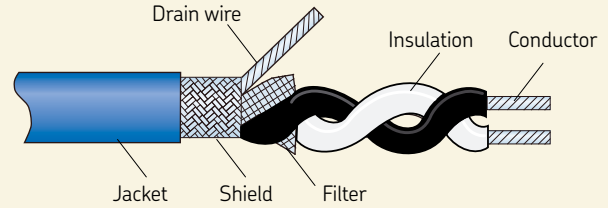

Dimensions

- Conductor: 0,96 mm (0.038 in.) nominal
- Insulation: 1,40 mm (0.058 in.) nominal
- Drain wire: 0,61 mm (0.024 in.) nominal
- Shield: 3,50 mm (0.138 in.) nominal
- Jacket: 4,80 mm, ±0,1 mm (0.190 in., ±0.005 in.)

Environmental

- Minimum bend radius: 48 mm (1.9 in.)
- Working temperature range: -80 to +200 °C (-110 to +390 °F)
- Heat and flame resistance: Non-flame propagating
- Plenum rated
- Meets ROHS requirements

Electrical

- Capacitance: Approximately 89 pF/m (27 pF/ft.)
- Voltage rating: 600 V RMS maximum continuous use

Color code

- Two wire conductors:
 - A = White = Acceleration signal/power
 - B = Black = Common
- Three wire conductors:
 - A = Red = Acceleration signal/power
 - B = Black = Acceleration and temperature common
 - C = White = Temperature signal
- Jacket: Yellow (Y) or blue (B)

Ordering information

- **CMSS 932-SY-150M** Two-conductor, twisted pair, single shield, yellow cable with continuous cable length, 150 m (500 ft.) spool.
- **CMSS 932-SY-300M** Two-conductor, twisted pair, single shield, yellow cable with continuous cable length, 300 m (1 000 ft.) spool.
- **CMSS 932-DY-150M** Two-conductor, twisted pair, double shield, yellow cable with continuous cable length, 150 m (500 ft.) spool.
- **CMSS 932-SB-150M** Two-conductor, twisted pair, single shield, blue cable with continuous cable length, 150 m (500 ft.) spool.
- **CMSS 933-SY-150M** Three-conductor, triad, single shield, yellow cable with continuous cable length, 150 m (500 ft.) spool.

Industrial cable connector assemblies for vibration sensors

CMSS 932-68

The CMSS 932-68 are rugged cable connector assemblies designed for use with piezoelectric vibration sensors, which require high specification shielded cable to maximize the quality of the signal transmitted to the monitoring system. The assemblies are ingress protection rated (IP 68): allow no ingress of dust and are suitable for continuous immersion in water. The CMSS 932-68 are two-wire assemblies using a single or double shield, twisted pair cable with the conductors individually insulated with a fluorine based polymer, a braided shield with drain wire and an outer insulated jacket also made of a fluorine based polymer.

The double shielded option adds an inner shield of aluminum polyester foil with drain wire. There are two wire colors (jackets) available:

- Yellow: For high visibility in the often dusty and debris laden industrial environment
- Blue: For use in intrinsically safe circuits in the Oil/Gas and Hydrocarbon processing industries

Specifications

Cables

Two insulated conductors are cabled together with one uninsulated drain wire and two glass cord fillers.

Materials

- Conductor: Tin plated copper, 19 × 32 strands, size 20 AWG (American Wire Gauge)
- Insulation: Extruded FEP
- Drain wire: Tin plated copper, 7 × 32 strands, size 24 AWG
- Shield: 36 AWG tin plated copper braid
- Jacket: Extruded FEP
- Molded boot: Black fluoroelastomer, offering better chemical resistance
- Adaptor / locking rings: Stainless steel

Color code

- Two wire conductors:
 - A = White = Acceleration signal/power
 - B = Black = Common
- Jacket: Yellow (Y) or blue (B)



Dimensions

- Conductor: 0,96 mm (0.038 in.) nominal
- Insulation: 1,40 mm (0.058 in.) nominal
- Drain wire: 0,61 mm (0.024 in.) nominal
- Shield: 3,50 mm (0.138 in.) nominal
- Jacket: 4,80 mm, ±0,1 mm (0.190 in., ±0.005 in.)

Electrical

- Capacitance: Approximately 89 pF/m (27 pF/ft.)
- Voltage rating: 600 V RMS maximum continuous use

Environmental

- Minimum bend radius: 48 mm (1.9 in.)
- Working temperature range: -80 to +200 °C (-110 to +390 °F)
- Heat and flame resistance: Non-flame propagating
- Plenum rated
- Meets ROHS requirements

Connectors

MIL-style stainless steel connectors are designed for use with SKF sensors. There are two different styles of IP 68 connectors:



CMSS 932-68TLX-SY-XXM: IP 68 sensor/connector/cable assembly with twist lock.

The fluoroelastomer boot and a quarter twist locks the assembly into a tight fit.



CMSS 932-68LCX-XX-XXX: IP 68 sensor/connector/cable assembly with locking collar.

The locking collar is a threaded connector that threads onto an accompanying sensor adapter. It is recommended to secure the sensor adapter to the accelerometer connector using thread lock (Loctite). The locking collar features an O-ring and metal locking ring and is therefore more suitable for applications under water.

Ordering example

CMSS 932-68TLI-SY-10M

- Two-wire, IP 68 connector, twist lock, isolated, single shield, yellow, 10 m (32.8 ft.) length

CMSS 932-68LCN-SY-20M

- Two-wire, IP 68 connector, locking collar, non-isolated, single shield, yellow, 20 m (65.6 ft.) length

Note: Isolated connectors cannot be selected with double shielded cables (e.g., part number CMSS 932-68LCI-DY-XXM is not valid). As such, if a double shielded cable is required (shield = **D**), select a non-isolated connector (non-isolated = **N**); for example:

- CMSS 932-68LCN-DY-5M

If an isolated connector is required (isolated = **I**), select a single shielded cable (shield = **S**); for example:

- CMSS 932-68LCI-SY-5M

Double shielded cable should be grounded on both sides: the instrument side and the sensor side (through the machine). If an isolated connector is selected with a double shielded cable, the sensor side will be cut off and never connected to the sensor ground.

Ordering information

CMSS 932 Two-wire twisted pair cable / two-pin connector assembly.

Part number		CMSS 932-68aab-cd-eeM
68	IP 68 connector (immersion)	
aa	Lock type	
TL	Twist lock	
LC	Locking collar	
b	Isolated/Non-isolated	
I	Isolated (must use single shielded)	
N	Non-isolated	
c	Shield	
D	Double shielded (must use non-isolated)	
S	Single shielded	
d	Jacket	
Y	Yellow jacket	
B	Blue jacket	
eeM	Length	
5M	Length: 5 m (16.4 ft.)	
10M	Length: 10 m (32.8 ft.)	
20M	Length: 20 m (65.6 ft.)	
XXM	Length: Specify XX meters, in 5 m increments	

Junction boxes and enclosures



CMSS 260, CMSS 265, CMSS 300 and CMSS 310 series

- CMSS 260 series NEMA 4 and NEMA 4X enclosures
- CMSS 265 series termination junction boxes
- CMSS 300 series BNC junction boxes
- CMSS 310 series switchable BNC junction boxes

Industry standards

For all junction boxes and according to version (material)

Rating	Painted steel	Fiberglass	Stainless steel
UL 50	Type 4, 12 and 13	N/A	Type 3R, 4, 4X and 12
UL 508 A, UL 508	Type 4, 12 and 13	Type 3R, 4, 4X and 12	Type 3R, 4, 4X and 12
NEMA/EEMAC	Type 4, 12 and 13	Type 3R, 4, 4X and 12	Type 3R, 4, 4X and 12
JIC	EGP-1-1967	EGP-1-1967	EGP-1-1967
CSA	Type 4 and 12	Type 4, 4X and 12	Type 4, 4X and 12
IEC 60529	IP 66	IP 66	IP 66



CMSS 260 series NEMA 4 and NEMA 4X enclosures



CMSS 265 series termination junction boxes



CMSS 300 series BNC junction boxes



CMSS 310 series switchable BNC junction boxes

NEMA 4 and NEMA 4X enclosures



CMSS 260 series

NEMA 4 and NEMA 4X enclosures are provided by SKF for housing of any instrument

The enclosures' covers have a continuous hinge on the long side of the unit for convenience and are secured to the enclosure with clamps. The enclosures are available in NEMA 4 or NEMA 4X to cover most applications. All enclosures are provided with an oil resistant gasket and clamps for easy screwdriver access.



CMSS 260FG

NEMA 4X fiberglass enclosures

NEMA 4X fiberglass enclosures are designed for use in areas that may be regularly hosed down or are very wet, and they are suitable for indoor or outdoor installations.

The enclosure is used in highly corrosive environments typically found in oil refineries, chemical processing plants, wastewater treatment, marine installations, pulp and paper processing, and electroplating plants.

CMSS 260PS

NEMA 4 painted steel enclosures

These enclosures are designed for use in areas that may be regularly hosed down or are very wet, and they are suitable for indoor or outdoor installations. Wherever protection from dust, dirt, oil or hose-directed water is essential.

ANSI 61 powder coated on the interior and exterior surfaces, constructed from 14 gauge mild steel.

CMSS 260SS

NEMA 4X stainless steel enclosures

Constructed from 14 gauge 304 stainless steel rather than a mild steel. They are designed for the same use as the NEMA 4 enclosures with the ability to resist corrosive environments.

Ordering example: NEMA 4X fiberglass enclosure measuring 15,2 × 15,2 × 10,2 cm (6.0 × 6.0 × 4.0 in.) would be the SKF model number CMSS 260FG-01.

Ordering Information	
Description	CMSS 260FG-XX
-XX NEMA 4X fiberglass enclosures (dimensions: height × width × depth)	
01 15,2 × 15,2 × 10,2 cm (6.0 × 6.0 × 4.0 in.)	
02 20,3 × 15,2 × 8,9 cm (8.0 × 6.0 × 3.5 in.)	
03 25,4 × 20,3 × 15,2 cm (10.0 × 8.0 × 6.0 in.)	

Ordering Information	
Description	CMSS 260PS-XX
-XX NEMA 4 painted steel enclosures (dimensions: height × width × depth)	
01 15,2 × 15,2 × 10,2 cm (6.0 × 6.0 × 4.0 in.)	
02 20,3 × 15,2 × 8,9 cm (8.0 × 6.0 × 3.5 in.)	
03 25,4 × 20,3 × 15,2 cm (10.0 × 8.0 × 6.0 in.)	

Ordering Information	
Description	CMSS 260SS-XX
-XX NEMA 4X stainless steel enclosures (dimensions: height × width × depth)	
01 15,2 × 15,2 × 10,2 cm (6.0 × 6.0 × 4.0 in.)	
02 20,3 × 15,2 × 8,9 cm (8.0 × 6.0 × 3.5 in.)	
03 25,4 × 20,3 × 15,2 cm (10.0 × 8.0 × 6.0 in.)	

Termination junction boxes

CMSS 265 series

Connecting centers by SKF



The CMSS 265 series termination junction boxes are multiple channel connecting centers for terminating the outputs of accelerometers or other transducer field wiring. Crew clamp, DIN-rail mounted terminals (three inputs per channel, usually signal, common and shield) are provided for the intermediate termination of accelerometers, proximity probes, speed sensors, RTDs and other transducers.

The CMSS 265 series junction boxes are available in three versions:

- NEMA 4X Fiberglass (FG)
- NEMA 4 Powder Coated Steel (PS)
- NEMA 4X Stainless Steel (SS)



CMSS 265FG

NEMA 4X fiberglass junction boxes

The CMSS 265FG NEMA 4X enclosures are made of molded fiberglass polyester and is easily punched or drilled. It has outstanding chemical and temperature resistance and physical properties. A seamless foam in-place gasket assures a watertight and dust-tight seal. Screw covers are secured with captivated Monel cover screws.

CMSS 265PS

NEMA 4 powder coated steel junction boxes

The CMSS 265PS NEMA 4 enclosure is constructed of 14 gauge mild steel and is ANSI 61 gray polyester powder coated on the all surfaces. A seamless foam in-place gasket assures a watertight and dust-tight seal.

CMSS 265SS

NEMA 4X stainless steel junction boxes

The CMSS 265SS NEMA 4X enclosure is constructed from 14 gauge 304 stainless steel. This enclosure will better resist corrosive environments than the CMSS 265PS steel boxes. CMSS 265SS junction boxes feature continuously welded seams, ground smooth with no holes or knockouts. An oil-resistant, in-place gasket assures a watertight and dust-tight seal. Stainless steel screws and clamps are provided.

Ordering example: NEMA 4X stainless steel junction box with 16 channels and 48 terminals would be the SKF model number CMSS 265SS-16.

Ordering Information

Description	CMSS 265FG-XX
-XX NEMA 4X fiberglass junction boxes (dimensions: height × width × depth)	
02 2 channels, 6 terminals – 15,2 × 15,2 × 10,2 cm (6.0 × 6.0 × 4.0 in.)	
04 4 channels, 12 terminals – 15,2 × 15,2 × 10,2 cm (6.0 × 6.0 × 4.0 in.)	
08 8 channels, 24 terminals – 20,3 × 15,2 × 10,2 cm (8.0 × 6.0 × 4.0 in.)	
12 12 channels, 36 terminals – 25,4 × 20,3 × 15,2 cm (10.0 × 8.0 × 6.0 in.)	
16 16 channels, 48 terminals – 35,6 × 30,5 × 20,3 cm (14.0 × 12.0 × 8.0 in.)	

Ordering Information

Description	CMSS 265PS-XX
-XX NEMA 4 powder coated steel junction boxes (dimensions: height × width × depth)	
02 2 channels, 6 terminals – 15,2 × 15,2 × 10,2 cm (6.0 × 6.0 × 4.0 in.)	
04 4 channels, 12 terminals – 15,2 × 15,2 × 10,2 cm (6.0 × 6.0 × 4.0 in.)	
08 8 channels, 24 terminals – 20,3 × 15,2 × 10,2 cm (8.0 × 6.0 × 4.0 in.)	
12 12 channels, 36 terminals – 25,4 × 20,3 × 15,2 cm (10.0 × 8.0 × 6.0 in.)	
16 16 channels, 48 terminals – 35,6 × 30,5 × 20,3 cm (14.0 × 12.0 × 8.0 in.)	

Ordering Information

Description	CMSS 265SS-XX
-XX NEMA 4X stainless steel junction boxes (dimensions: height × width × depth)	
02 2 channels, 6 terminals – 15,2 × 15,2 × 10,2 cm (6.0 × 6.0 × 4.0 in.)	
04 4 channels, 12 terminals – 15,2 × 15,2 × 10,2 cm (6.0 × 6.0 × 4.0 in.)	
08 8 channels, 24 terminals – 20,3 × 15,2 × 10,2 cm (8.0 × 6.0 × 4.0 in.)	
12 12 channels, 36 terminals – 25,4 × 20,3 × 15,2 cm (10.0 × 8.0 × 6.0 in.)	
16 16 channels, 48 terminals – 35,6 × 30,5 × 20,3 cm (14.0 × 12.0 × 8.0 in.)	

BNC junction boxes

CMSS 300 series

Easy to use high quality products



The CMSS 300 series BNC junction boxes are multiple channel connecting centers for terminating the outputs of accelerometers or other transducer field wiring. They are normally located in close proximity to the machine to reduce wiring cost and provide convenient access to the vibration signal by a portable data collector/analyzer.



Features

- Now easier to wire! Hold it in your hand
- More room for wiring and conduit entry
- Short connections for less noise
- Large Monel screw type terminals
- Quick and convenient access to remotely installed accelerometers with portable data collector/analyzer
- Withstands harsh factory and outdoor environments

Both internal and external switch/BNC models are available. Internal models are provided with quick access latches and external models with screw covers and protective caps for the BNC fitting. In harsh environments internal models should be specified. Black and white bezel tagging is provided for channel and switch identification.

The CMSS 300 series junction boxes are available in three versions:

- NEMA 4X Fiberglass (FG)
- NEMA 4 Powder Coated Steel (PS)
- NEMA 4X Stainless Steel (SS)

Ordering example: NEMA 4 powder coated steel BNC junction box with six channels and external BNC would be the SKF model number CMSS 300FG-06-02.

CMSS 300FG

NEMA 4X fiberglass BNC junction boxes

The CMSS 300FG NEMA 4X fiberglass enclosure is made of molded fiberglass polyester and is easily punched or drilled. It has outstanding chemical and temperature resistance and physical properties.

A seamless foam in-place gasket assures a water tight and dust tight seal. Screw covers are secured with captivated Monel cover screws.

Ordering Information

Description	CMSS 300FG-XX-XX
-XX NEMA 4X fiberglass BNC junction boxes (dimensions: height x width x depth)	
01 1 channel – 20,3 x 18,5 x 11,2 cm (8.00 x 7.29 x 4.41 in.)	
02 2 channels – 20,3 x 18,5 x 11,2 cm (8.00 x 7.29 x 4.41 in.)	
04 4 channels – 20,3 x 18,5 x 11,2 cm (8.00 x 7.29 x 4.41 in.)	
06 6 channels – 25,4 x 18,5 x 11,2 cm (10.00 x 7.29 x 4.41 in.)	
-XX Internal/External BNC	
01 Internal BNC	
02 External BNC	

CMSS 300PS

NEMA 4 powder coated steel BNC junction boxes

The CMSS 300PS powder coated steel NEMA 4 enclosure is constructed of 14 gauge mild steel and is ANSI 61 gray polyester powder coated on the all surfaces.

Ordering Information

Description	CMSS 300PS-XX-XX
-XX NEMA 4 powder coated steel BNC junction boxes (dimensions: height × width × depth)	
01 1 channel – 19,1 × 17,8 × 10,8 cm (7.50 × 7.00 × 4.24 in.)	
02 2 channels – 19,1 × 17,8 × 10,8 cm (7.50 × 7.00 × 4.24 in.)	
04 4 channels – 19,1 × 17,8 × 10,8 cm (7.50 × 7.00 × 4.24 in.)	
06 6 channels – 25,4 × 17,8 × 10,7 cm (10.00 × 7.00 × 4.21 in.)	
-XX Internal/External BNC	
01 Internal BNC	
02 External BNC	

CMSS 300SS

NEMA 4X stainless steel BNC junction boxes

The CMSS 300SS NEMA 4X stainless steel enclosure is constructed from 14 gauge 304 stainless steel.

Ordering Information

Description	CMSS 300SS-XX-XX
-XX NEMA 4X stainless steel BNC junction boxes (dimensions: height × width × depth)	
01 1 channel – 19,1 × 17,8 × 10,9 cm (7.50 × 7.00 × 4.28 in.)	
02 2 channels – 19,1 × 17,8 × 10,9 cm (7.50 × 7.00 × 4.28 in.)	
04 4 channels – 19,1 × 17,8 × 10,9 cm (7.50 × 7.00 × 4.28 in.)	
06 6 channels – 24,1 × 17,8 × 10,7 cm (9.50 × 7.00 × 4.21 in.)	
-XX Internal/External BNC	
01 Internal BNC	
02 External BNC	

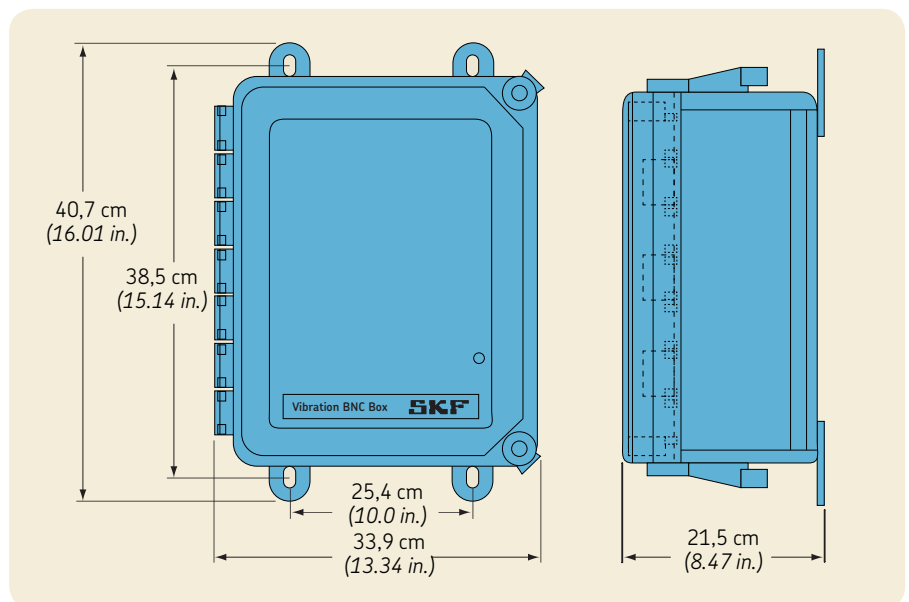

Dimension example:
CMSS 300SS-06-01

Switchable BNC junction boxes



CMSS 310 series

Convenient, quick and safe

The CMSS 310 series switchable BNC junction boxes are designed for terminating and switching the outputs of up to 48 accelerometers. They are installed in a location as close to the machine as practical to reduce wiring cost and yet provide convenient safe access to the vibration signal by an operator with a portable data collector/analyzer.

Features

- ROHS compliant
- Easier wiring, switch module (front panel) can be disconnected from the back board
- Large Monel screw type terminals

The CMSS 310 series switchable BNC junction boxes are available in three versions:

- NEMA 4X Fiberglass (FG)
- NEMA 4 Powder Coated Steel (PS)
- NEMA 4X Stainless Steel (SS)

Both internal and external switch/BNC models are available. Internal models are provided with quick access latches, and external models with screw covers and protective caps for the BNC fitting. In harsh environments internal models should be specified. Black and white bezel tagging is provided for channel and switch identification.



CMSS 310FG

NEMA 4X fiberglass switchable BNC junction boxes

The CMSS 310FG NEMA 4X fiberglass enclosure is made of molded fiberglass polyester and is easily punched or drilled. It has outstanding chemical and temperature resistance and physical properties.

A seamless foam in-place gasket assures a watertight and dust-tight seal. Screw covers are secured with captivated Monel cover screws.

Ordering Information

Description	CMSS 310FG-XX-XX
-XX NEMA 4X fiberglass switchable BNC junction boxes (dimensions: height × width × depth)	
06 6 channels – 25,4 × 18,5 × 11,2 cm (10.00 × 7.29 × 4.41 in.)	
12 12 channels – 25,4 × 18,5 × 11,2 cm (10.00 × 7.29 × 4.41 in.)	
24 24 channels – 40,7 × 33,9 × 21,5 cm (16.01 × 13.34 × 8.47 in.)	
32 32 channels – 45,7 × 39,0 × 21,5 cm (18.01 × 15.34 × 8.47 in.)	
48 48 channels – 45,7 × 39,0 × 21,5 cm (18.01 × 15.34 × 8.47 in.)	
-XX Internal/External BNC	
01 Internal BNC	
02 External BNC	

CMSS 310PS

NEMA 4 powder coated steel BNC junction boxes

The CMSS 310PS NEMA 4 powder coated steel enclosure is constructed of 14 gauge mild steel and is ANSI 61 gray polyester powder coated on the all surfaces.

Ordering Information

Description	CMSS 310PS-XX-XX
-XX NEMA 4 powder coated steel BNC junction boxes (dimensions: height × width × depth)	
06 6 channels – 24,1 × 17,8 × 9,6 cm (9.50 × 7.00 × 3.79 in.)	
12 12 channels – 24,1 × 17,8 × 9,6 cm (9.50 × 7.00 × 3.79 in.)	
24 24 channels – 39,4 × 33,1 × 21,1 cm (15.50 × 13.02 × 8.29 in.)	
32 32 channels – 44,5 × 38,2 × 21,1 cm (17.50 × 15.02 × 8.29 in.)	
48 48 channels – 44,5 × 38,2 × 21,1 cm (17.50 × 15.02 × 8.29 in.)	
-XX Internal/External BNC	
01 Internal BNC	
02 External BNC	

CMSS 310SS

NEMA 4X stainless steel BNC junction boxes

The CMSS 310SS NEMA 4X stainless steel enclosure is constructed from 14 gauge 304 stainless steel.

Ordering Information

Description	CMSS 310SS-XX-XX
-XX NEMA 4X stainless steel BNC junction boxes (dimensions: height × width × depth)	
06 6 channels – 24,1 × 17,8 × 10,9 cm (9.50 × 7.00 × 4.28 in.)	
12 12 channels – 24,1 × 17,8 × 10,9 cm (9.50 × 7.00 × 4.28 in.)	
24 24 channels – 39,4 × 33,1 × 16,0 cm (15.50 × 13.02 × 6.29 in.)	
32 32 channels – 44,5 × 38,2 × 21,1 cm (17.50 × 15.02 × 8.29 in.)	
48 48 channels – 44,5 × 38,2 × 21,1 cm (17.50 × 15.02 × 8.29 in.)	
-XX Internal/External BNC	
01 Internal BNC	
02 External BNC	

CMSS 261

Liquid tight strain relief connectors

The CMSS 261 liquid tight strain relief connectors are used for either extension cable or multi-conductor wire entries into the CMSS 310 BNC junction boxes. Connectors are constructed of Polyamide and provide both environmental sealing and strain relief. The connectors are temperature rated to -60 to $+100$ °C (-40 to $+210$ °F) and have a pressure rating of up to 150 PSIG. Check the cable data sheet for the diameter of your extension cable.

Ordering Information

Description / Outer cable diameter (minimum/maximum)

CMSS 261-XX

-XX	Liquid tight strain relief connectors
01	2 mm (0.08 in.) / 5 mm (0.20 in.)
02	4 mm (0.16 in.) / 8 mm (0.31 in.)
03	5 mm (0.20 in.) / 9 mm (0.35 in.)
04	7 mm (0.28 in.) / 12 mm (0.47 in.)
05	9 mm (0.35 in.) / 18 mm (0.70 in.)
06	13 mm (0.51 in.) / 20 mm (0.78 in.)

Ordering example: NEMA 4X fiberglass switchable BNC junction box with 24 channels and internal BNC would be the SKF model number CMSS 310FG-24-01.

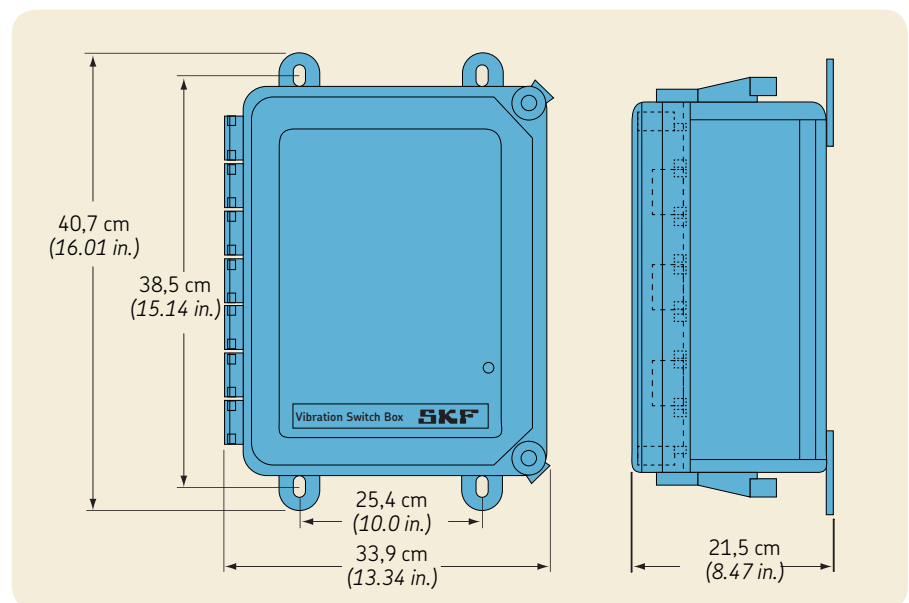

Dimension example: CMSS 310SS-24-01.

SKF Machine Condition Transmitter (MCT) systems

CMSS 5301 / CMSS 5302

One and two channel, complete MCT system

The CMSS 5301 (one channel) and CMSS 5302 (two channel) are vibration monitors that have been designed for use on typical rotating machinery such as motors, pumps, fans, turbines, compressors, chillers, etc.

Features

- Two levels of alarm with relays
- True "OK" circuitry with relay
- Adjustable time delays
- Trip multiply
- 4 to 20 mA output
- Buffered transducer output
- Reset button
- Bright LED digital readout
- Class I, Division 2 rated transmitters with monitors

Description

The CMSS 5301 and CMSS 5302 accept inputs from any industry standard 100 mV/g accelerometer, conditions the input signals and provides a digital display and alarm status indication.

Analog outputs (4 to 20 mA) are provided for each channel for interface to a PLC or DCS for trending, alarm and operator interface. The alarm contacts for the OK circuit and for Alert and Danger may be interfaced to machine control and shutdown systems for a complete vibration protection solution.

Example of SKF MCT system configuration.

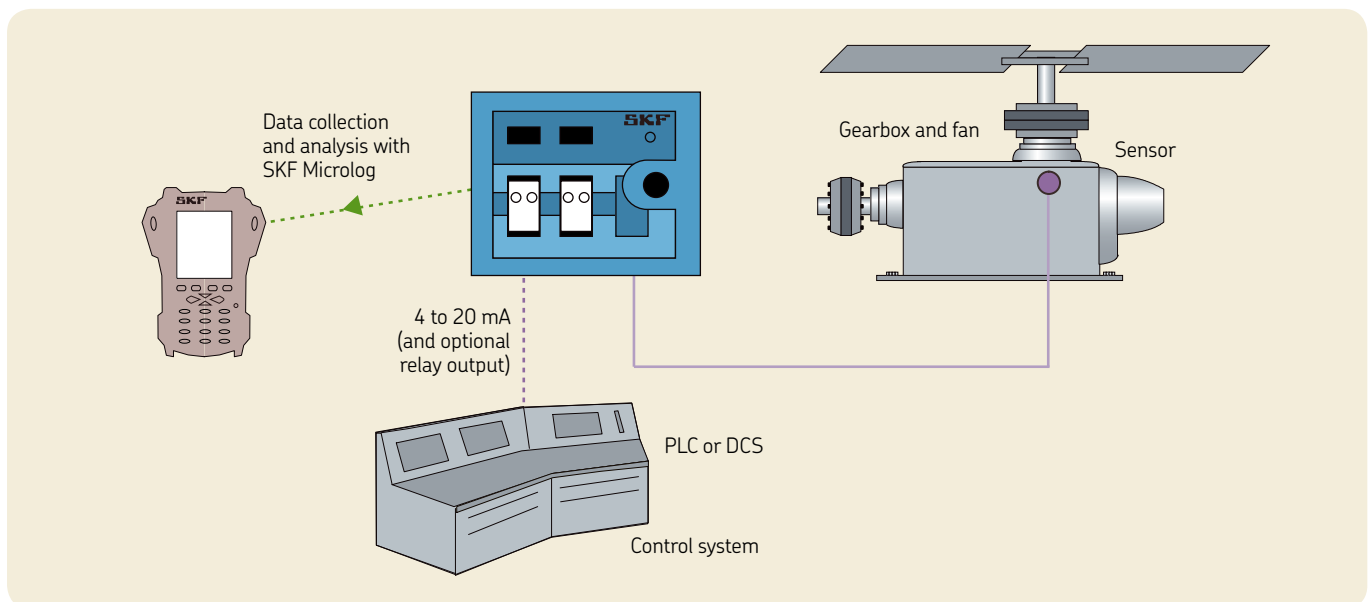

The system is a pre-wired, turnkey package with power supply and bright LED displays. The power supply accepts 110 or 220 V AC, 50 or 60 Hz. They are available in either an Imperial or Metric configuration. The standard enclosure is NEMA 4X fiberglass; powder coated steel and stainless steel enclosures are available.

Specifications (both models)

Physical

- Dimensions:
 - Fiberglass (FG), single and dual channel: 28,5 × 15,5 × 23,4 cm (11.21 × 6.09 × 9.20 in.)
 - Powder-coated steel (PS) and stainless steel (SS), single channel: 25,0 × 15,0 × 20,3 cm (9.84 × 5.90 × 7.98 in.)
 - Powder-coated steel (PS) and stainless steel (SS), dual channel: 30,0 × 15,0 × 25,0 cm (11.81 × 5.91 × 9.85 in.)
- The steel enclosures (PS and SS) have a slightly different design with the door hinges on top.

Electrical

- Power: Accepts 110 or 220 V AC, 50 or 60 Hz
- Case: Isolated

Input

- Sensor: Accelerometer, 100 mV/g
- Sensor OK detection: Continuously monitors the transmitter bias and signal voltage; if this voltage exceeds preset limits, the 4 to 20 mA output current is reduced to less than 2 mA

Output

- Sensitivity: Depending on used sensor's input sensitivity, ±10%
- 4 to 20 mA DC output: 4 to 20 mA proportional to full scale range
- Accuracy: ±5% with single pole filter; -3 dB points at 2 Hz and 2 kHz
- Buffered output: BNC connector 0 to 20 kHz
- Maximum load: 600 Ω resistive per channel

Environmental

- Operating temperature: -20 to +80 °C (-5 to +175 °F)
- Storage temperature: -55 to +125 °C (-65 to +260 °F)
- Relative humidity: 0 to 95% non-condensing
- Approvals: NEMA 4X

Ordering information

CMSS 5301: One channel complete Machine Condition Transmitter System with display and NEMA 4X fiberglass enclosure:

- CMSS 5301FG-E: CMSS 530A100A-ER-ISOLF, 0 to 1 in./s, RMS, universal power supply
- CMSS 5301FG-M: CMSS 530A100A-MR-ISOLF, 0 to 25 mm/s, RMS, universal power supply
- CMSS 5301FG-ENV: CMSS 590A100A, 0 to 10 gE, universal power supply

Enclosures are available in:

- Fiberglass NEMA 4X (standard)
- Powder coated steel NEMA 4 (CMSS 5301PS)
- Stainless steel NEMA 4X (CMSS 5301SS)
- Custom cast aluminum for explosion-proof application is available upon request

CMSS 5302: Two channel complete Machine Condition Transmitter System with displays and NEMA 4X fiberglass enclosure:

- CMSS 5302FG-E: Two CMSS 530A100A-ER-ISOLF, 0 to 1 in./s, RMS, universal power supply
- CMSS 5302FG-M: Two CMSS 530A100A-MR-ISOLF, 0 to 25 mm/s, RMS, universal power supply
- CMSS 5302FG-ENV: Two CMSS 590A100A, 0 to 10 gE, universal power supply
- CMSS 5302FG-E-ENV: One CMSS 530A100A-ER-ISOLF, one CMSS 590A100A, universal power supply
- CMSS 5302FG-M-ENV: One CMSS 530A100A-MR-ISOLF, one CMSS 590A100A, universal power supply
- CMSS 5302FG-E-ENV-MS: One CMSS 530A100A-ER-ISOLF, one CMSS 590A100A, universal power supply
- CMSS 5302FG-M-ENV-MS: One CMSS 530A100A-MR-ISOLF, one CMSS 590A100A, universal power supply

The CMSS 5301 and CMSS 5302 are also available with any other CMSS 500 series monitor.

Example: Part ID CMSS 5302SS-E-ENV-MS: Master-slave configuration, specifies one Velocity MCT with Imperial units and one Enveloped Acceleration MCT, configured to work with one sensor (for dual-parameter measurements).



Ordering information

CMSS 5301 Single channel monitoring system with display
CMSS 5302 Dual channel monitoring system with displays

Part number	CMSS 530VWW-X-YYY-ZZ
V	Number of channels
1	Single channel
2	Dual channel
WW	Enclosure
FG	Fiberglass
PS	Powder-coated steel
SS	Stainless steel
X	Transmitter type
E	Velocity, Imperial, CMSS 530A100A-ER-ISOLF
M	Velocity, Metric, CMSS 530A100A-MR-ISOLF
ENV	Enveloped acceleration, CMSS 590A100A
YYY	Transmitter mix
ENV	One velocity and one enveloped acceleration
ZZ	Transmitter configuration
MS	Master and slave configuration, two transmitters, one sensor



Please contact:

SKF USA Inc.

Condition Monitoring Center – San Diego

5271 Viewridge Court · San Diego, California 92123 USA

Tel: +1 858-496-3400 · Fax: +1 858 496-3531

Web: www.skf.com/cm

© SKF, @PTITUDE and MICROLOG are registered trademarks of the SKF Group.

Microsoft, Windows, Windows Mobile, Excel and Word are registered trademarks or trademarks of Microsoft Corporation in the United States and/or other countries.

Android and Nexus 7 are trademarks of Google Inc.

ASUS is a registered trademark of ASUSTek Computer.

BizPad and Toughpad are registered trademarks of Panasonic Corporation.

HTC and HTC One are trademarks of HTC Corporation.

IdeaPad is a registered trademark of Lenovo in the United States and/or other countries.

Regza is a registered trademark of Toshiba Corporation.

Loctite is a registered trademark of Henkel Corporation.

All other trademarks are the property of their respective owners.

© SKF Group 2014

The contents of this publication are the copyright of the publisher and may not be reproduced (even extracts) unless prior written permission is granted. Every care has been taken to ensure the accuracy of the information contained in this publication but no liability can be accepted for any loss or damage whether direct, indirect or consequential arising out of the use of the information contained herein.

Patents: US 4,768,380 · US 5,679,900 · US 5,845,230 · US 5,854,553 · US 5,992,237 · US 6,006,164 · US 6,199,422 · US 6,202,491 · US 6,275,781 · US 6,489,884 · US 6,513,386 · US 6,633,822 · US 6,789,025 · US 6,792,360 · WO/2003/048714 · US 5,633,811 · US 5,870,699 · US 6,437,692 · US 7,103,511 · US 7,697,492

PUB CM/P1 11704/6 EN · May 2014