

# Bearing heaters



# It's a fact.

## Incorrect mounting methods account for up to 16% of premature bearing failures

To reduce the risk of incorrect mounting, SKF helped pioneer the use of portable induction heaters for bearing mounting applications in the 1970's. Since that time, there have been many advances in technology and SKF has been at the forefront in developing safer, more efficient and user-friendly bearing induction heaters.

SKF induction heaters are probably the best performing heaters available. Their unique design typically consumes just 50% of the electrical power needed by most competitor's bearing induction heaters to heat a bearing.

As result, by using an SKF induction heater, the total cost of ownership is often significantly lower. Ergonomics and safety are also an important consideration for operators. SKF induction heaters are equipped with design features that make them easy to use and safe. Bearing support arms reduce the risk of the bearing toppling during heating, and ergonomically designed yokes help reduce operator fatigue. In addition, the unique remote control enables the operator to control the heater at a safe distance from the hot bearing, enhancing operator safety.

## Induction heating has many advantages over other bearing heating methods

The use of an open flame to heat a bearing is not only inefficient and uncontrolled, but often leads to bearing damage. This method should not be used.

Oil baths are sometimes used to heat bearings. Oil baths often take a long time to reach the required temperature and can be difficult to control the actual bearing temperature. The energy consumption of an oil bath is also significantly greater than using an induction heater. The risk of contaminating the bearing, due to dirty oil, is significant and can lead to premature bearing failure. Handling hot, oily and slippery bearings present significant hazards to the operator and great care must be taken to avoid potential injuries.

Ovens and hot plates are often used for batch heating of small bearings and this is an acceptable technique. However, for larger bearings, the use of ovens and hotplates is generally quite inefficient and time consuming and can present the operator with significant handling hazards.

Induction heaters are the modern, efficient and safe way to heat bearings. In operation, they are generally faster, cleaner, more controllable, and easier to use than other heating methods.

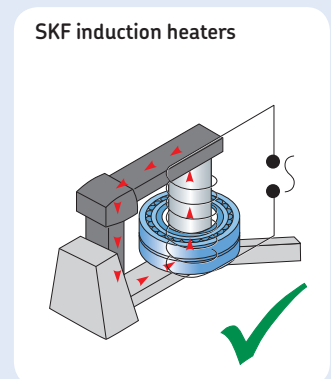
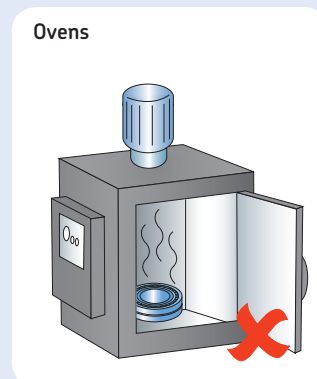
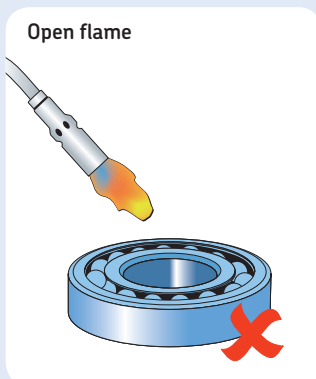

## Features and benefits

The comprehensive SKF induction header range can be used for efficiently heating bearings and workpieces, both large and small. Their innovative design offers significant advantages to both owners and operators:

- Advanced power electronics, with accurate electric current control, helps control the temperature rate increase
- Two step power setting option (50% / 100%), enables small bearings to be heated safely and at a lower power consumption
- For heating components other than bearings, all heaters are equipped with a heating time mode
- Thermal overheating protection reduces the risk of damage to the induction coil and the electronics, enhancing reliability and safety
- Automatic demagnetisation reduces the risk of ferrous debris contamination after heating
- Available in different voltage variants, to suit most operating voltages worldwide
- Supplied with heat resistant gloves for improved operator safety
- Comprehensive 3 year warranty

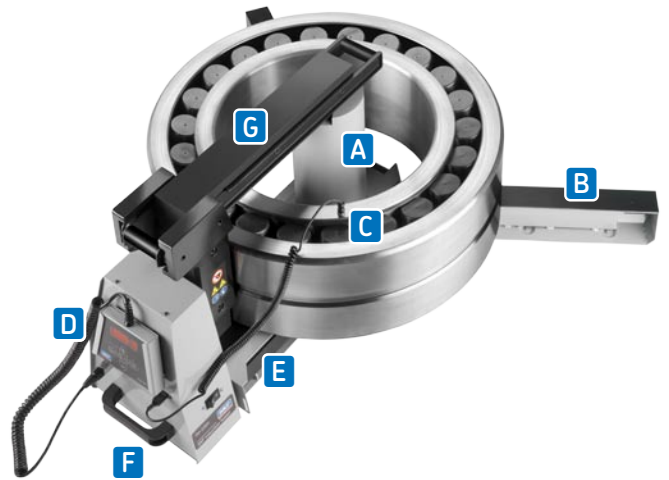

- A** Induction coil located outside the heater's housing enables a shorter heating time and lower energy consumption
- B** Foldable bearing support arms allow larger diameter bearings to be heated, and reduce the risk of the bearing toppling during heating
- C** Magnetic temperature probe, combined with a temperature mode pre-set at 110 °C (230 °F), helps prevent bearing overheating
- D** Unique SKF remote control, with operating display and control panel, makes the heater easy and safe to use
- E** Internal yoke storage, for smaller yoke(s), reduces the risk of yoke damage or loss
- F** Integrated carrying handles allow for easy movement of the heater in the workshop
- G** Sliding or swivel arm allows for easy and quick bearing replacement, reducing operator fatigue (not for TIH 030m)

## SKF induction heater range

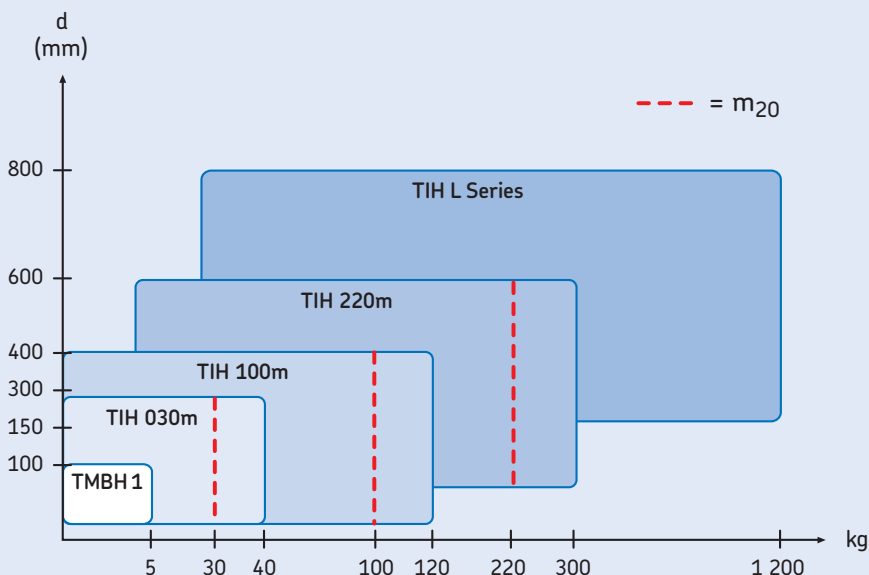

The comprehensive range of SKF induction heaters is suitable for most bearing heating applications. The chart below gives general information on the application range.

The SKF  $m_{20}$  concept represents the weight (kg) of the heaviest SKF spherical roller bearing of series 231 which can be heated from 20 to 110 °C (68 to 230 °F) in 20 minutes. This defines the heater's power output instead of its power consumption. Unlike other bearing heaters, there is a clear indication on how long it takes to heat a bearing, rather than just the maximum bearing weight possible.



## TMBH 1

### Portable induction heater weighing only 4,5 kg

- Portable, lightweight, high efficiency heater suits bearings with an inner diameter ranging from 20 to 100 mm (0.8 to 4 in.), and a maximum weight of 5 kg (11 lbs)
- Equipped with temperature and time control and automatic demagnetisation
- Supplied in a carrying case
- Wide operating voltage: 100–240 V/50–60 Hz



## TIH 030m

### Small induction heater with a 40 kg bearing heating capacity

- Compact lightweight design; just 21 kg (46 lbs), facilitating portability
- Capable of heating a 28 kg (62 lbs) bearing in just 20 minutes
- Supplied standard with three yokes, allowing bearings with a bore diameter from 20 mm (0.8 in.) up to a maximum weight of 40 kg (90 lbs) to be heated
- Available in two versions: 230 V/50–60 Hz and 100–110 V/50–60 Hz

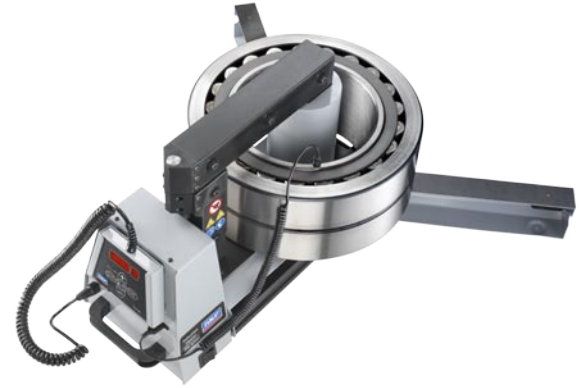

## TIH 100m

### Medium induction heater with a 120 kg bearing heating capacity

- Capable of heating a 97 kg (215 lbs) bearing in less than 20 minutes
- Supplied standard with three yokes, allowing bearings with a bore diameter from 20 mm (0.8 in.) up to a maximum weight of 120 kg (265 lbs) to be heated
- Swivel arm for large size yoke
- Available in two versions: 230 V/50–60 Hz and 400–460 V/50–60 Hz

## Multi-core induction heaters, TIH MC series

### A unique and flexible heating solution for very large bearings and workpieces

The SKF multi-core induction heaters are energy efficient, custom-made heating solutions. Compared to other heating methods, they often can significantly save heating time. The TIH MC series are similar to the standard TIH range, with a few key differences and additional features:

- Flexible design, consisting of a number of induction heating cores and coils controlled by a single control and power cabinet
- Suitable for heating large thin section workpieces, such as slewing rings and railway wheel tyres
- Heating capacities of several tonnes are possible, depending on application
- Enables a more even temperature gradient across the whole circumference. This is especially important for components sensitive to uneven induction heating
- Unique design allows for custom-made solutions to be quickly and economically produced
- SKF can configure the type of TIH MC series heater required, depending on the application. For additional information, contact your SKF authorized distributor

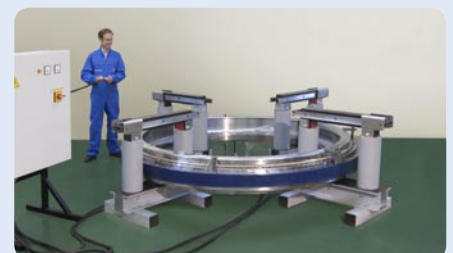



## TIH 220m

Large induction heater with a 300 kg bearing heating capacity

- Capable of heating a 220 kg (480 lbs) bearing in just 20 minutes
- Supplied standard with two yokes, allowing bearings with a bore diameter from 60 mm (2.3 in.) up to a maximum weight of 300 kg (660 lbs) to be heated
- Sliding arm for large size yoke
- Available in two versions: 230 V/50–60 Hz and 400–460 V/50–60 Hz.



## TIH L series

Extra large induction heater with a 1 200 kg bearing heating capacity

- Using just 20 kVA of electrical power, the TIH L series can heat large bearings up to 1 200 kg (2 600 lbs)
- Bearings and work pieces can be heated vertically or horizontally
- Compact design allows the TIH L series heaters to be easily transported by forklift
- Available in two versions: 230 V/50–60 Hz and 400–460 V/50–60 Hz.
- Available with two different operating areas

## Electric hot plate 729659 C

Thermostat controlled bearing heating

The SKF electric hot plate, 729659 C, is a heating device especially designed for pre-heating batches of small bearings prior to mounting. The temperature of the plate can be adjusted to provide temperatures between 50 and 200 °C (120 and 390 °F). The flat heating surface ensures an even heating of the bearings and the cover helps retain heat and keep contaminants out.



## SKF heaters for dismantling

Aluminium heating rings and adjustable / fixed induction heaters

Aluminium heating rings and adjustable / fixed induction heaters can be used for the dismantling of cylindrical roller bearing inner rings. The induction heaters can typically remove the inner ring in just three minutes, even when the ring has a heavy interference fit on the shaft.

TMBR series



EAZ series



## Technical data



Designation	TMBH 1	TIH 030m	TIH 100m	TIH 220m/LV TIH 220m/MV	TIH L44/LV TIH L44/MV	TIH L77/LV TIH L77/MV
Max workpiece weight	5 kg (11 lbs)	40 kg (88 lbs)	120 kg (264 lbs)	300 kg (662 lbs)	1 200 kg (2 600 lbs)	
Bore diameter range	20–100 mm (0.8–4 in.)	20–300 mm (0.8–11.8 in.)	20–400 mm (0.8–15.7 in.)	60–600 mm (2.3–23.6 in.)	100–800 mm (3.9–31.5 in.)	
Operating area (w × h)	52 × 52 mm (2 × 2 in.)	100 × 135 mm (3.9 × 5.3 in.)	155 × 205 mm (6.1 × 8 in.)	250 × 255 mm (9.8 × 10 in.)	TIH L44: 425 × 492 mm (16.7 × 19.4 in.) TIH L77: 725 × 792 mm (28.4 × 31.2 in.)	
Coil diameter	N/A	95 mm (3.7 in.)	110 mm (4.3 in.)	140 mm (5.5 in.)	175 mm (6.8 in.)	
Standard yokes (included) to suit bearing/workpiece minimum bore diameter	20 mm (0.8 in.)	65 mm (2.6 in.) 40 mm (1.6 in.) 20 mm (0.8 in.)	80 mm (3.1 in.) 40 mm (1.6 in.) 20 mm (0.8 in.)	100 mm (3.9 in.) 60 mm (2.3 in.)	150 mm (5.9 in.)	
SKF m <sub>20</sub> * performance	N/A	28 kg (61.7 lbs)	97 kg (213 lbs)	220 kg (480 lbs)	N/A	
Max power consumption	350 Watt	2,0 kVA	3,6 kVA (230 V) 4,0–4,6 kVA (400–460 V)	10,0–11,5 kVA (400–460 V)	20–24 kVA (200–240 V)	
Voltage**						
100–240 V/50–60 Hz	TMBH 1	TIH 030m/110 V	TIH 100m/230 V	–	–	–
200–240 V/50–60 Hz	–	TIH 030m/230 V	TIH 100m/MV	TIH 220m/LV	TIH L../LV	TIH L../MV
400–460 V/50–60 Hz	–	–	–	TIH 220m/MV	TIH L../MV	–
Temperature control	0 to 200 °C (32 to 392 °F)	0 to 250 °C (32 to 482 °F)	0 to 250 °C (32 to 482 °F)	0 to 250 °C (32 to 482 °F)	0 to 250 °C (32 to 482 °F)	
Time control (minutes)	0–60	0–60	0–60	0–60	0–120	
Demagnetisation according to SKF norms	N/A	<2 A/cm	<2 A/cm	<2 A/cm	<2 A/cm	
Max temperature	200 °C (392 °F)	400 °C (750 °F)	400 °C (750 °F)	400 °C (750 °F)	400 °C (750 °F)	
Dimensions (w × d × h)	370 × 240 × 130 mm (15 × 9 × 5 in.)	450 × 195 × 210 mm (17.7 × 7.6 × 8.2 in.)	570 × 230 × 350 mm (22.4 × 9 × 13.7 in.)	750 × 290 × 440 mm (29.5 × 11.4 × 17.3 in.)	TIH L44: 1 200 × 600 × 850 mm (47.3 × 23.6 × 33.5 in.) TIH L77: 1 320 × 600 × 1 150 mm (52 × 23.6 × 45.3 in.)	
Total weight (incl. yokes)	4,5 kg (10 lbs)	20,9 kg (46 lbs)	42 kg (92 lbs)	86 kg (189 lbs)	TIH L44: 300 kg (660 lbs) TIH L77: 370 kg (815 lbs)	

\* SKF m<sub>20</sub> performance represents the weight (kg) of the heaviest SKF spherical roller bearing of series 231, which can be heated from 20 to 110 °C (68 to 230 °F) in 20 minutes.

\*\* Some special voltage versions are available for specific countries. For additional information, contact your SKF authorized distributor.

## SKF gloves for handling hot bearings



**TMBA G11\***  
Heat resistant up to  
150 °C (302 °F)



**TMBA G11ET**  
Heat resistant up to  
500 °C (932 °F)



**TMBA G11H**  
Heat and oil resistant  
up to 250 °C (482 °F)

\* Supplied with all SKF induction heaters.

© SKF is a registered trademark of the SKF Group.

© SKF Group 2010

The contents of this publication are the copyright of the publisher and may not be reproduced (even extracts) unless prior written permission is granted. Every care has been taken to ensure the accuracy of the information contained in this publication but no liability can be accepted for any loss or damage whether direct, indirect or consequential arising out of the use of the information contained herein.

PUB MP/P2 10921 EN · July 2010

