

Sealed SKF Explorer spherical roller bearings

Optimum protection against contaminants,
downtime and high maintenance costs

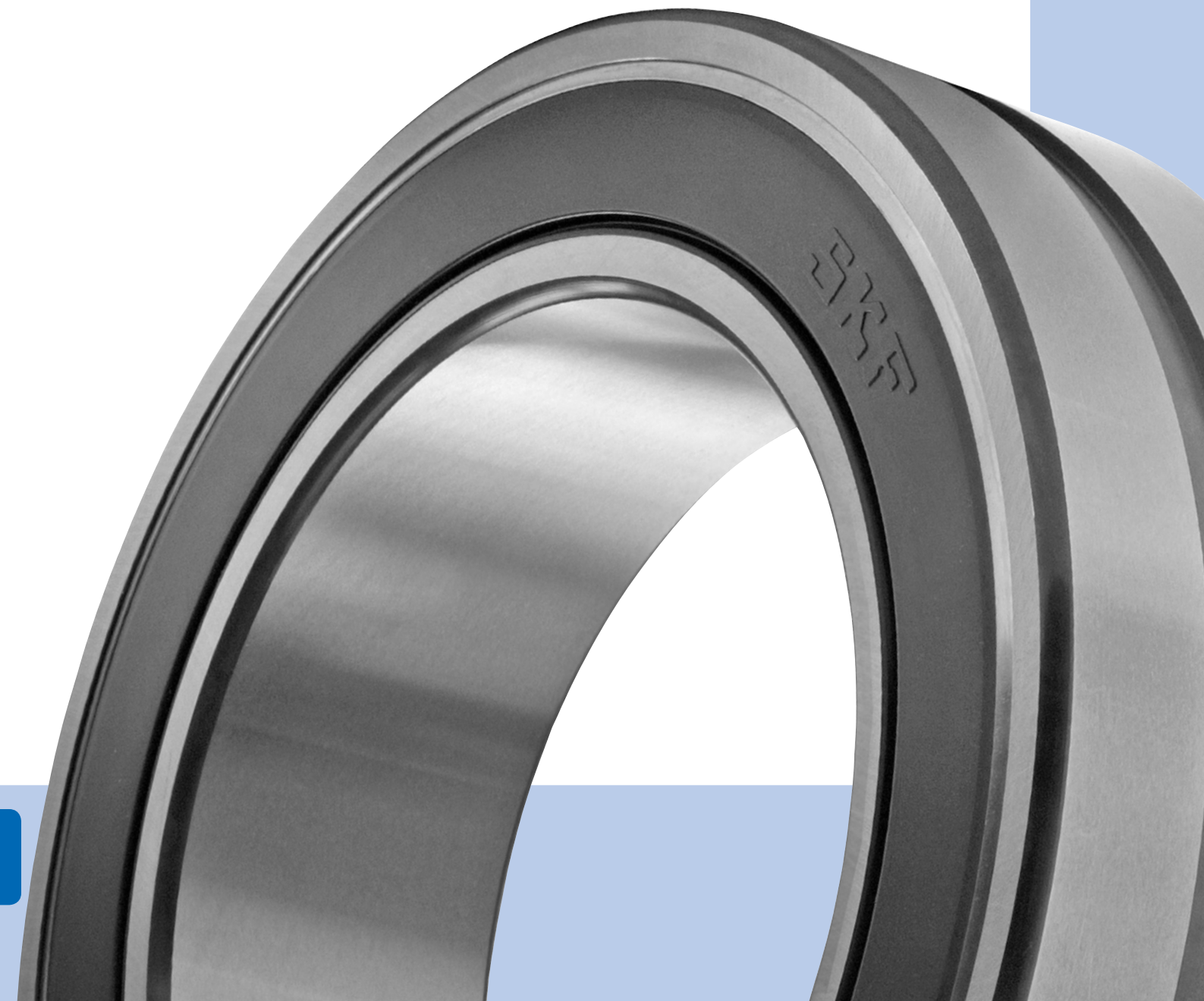



The SKF brand now stands for more than ever before, and means more to you as a valued customer.

While SKF maintains its leadership as a high-quality bearing manufacturer throughout the world, new dimensions in technical advances, product support and services have evolved SKF into a truly solutions-oriented supplier, creating greater value for customers.

These solutions enable customers to improve productivity, not only with breakthrough application-specific products, but also through leading-edge design simulation tools and consultancy services, plant asset efficiency maintenance programmes, and the industry's most advanced supply management techniques.

The SKF brand still stands for the very best in rolling bearings, but it now stands for much more.

SKF – the knowledge engineering company

Contents

A Product information

Robust, economical and environmentally friendly	3
Sealed SKF Explorer spherical roller bearings provide distinct benefits	3
Enhanced efficiency in most industrial segments	4

B Recommendations

Selection of bearing size	6
Bearing life	6
Sealed versus open spherical roller bearings – a comparison	7
Bearing arrangement design	8
Abutment dimensions	8
Bearing space considerations	8
The SKF three-barrier solution	8
Lubrication	9
Relubrication intervals	9
Grease quantity for relubrication	9
The rule of thumb for maintenance-free	9
Mounting and dismounting	10
Mounting	10
Dismounting	10

C Product data

Bearing data – general	11
Supplementary data	13
Designations	16
Product table	18

D Additional information

SKF – the knowledge engineering company	26
--	-----------

Robust, economical and environmentally friendly

Sealed SKF Explorer spherical roller bearings provide distinct benefits

SKF Explorer spherical roller bearings are well-proven products on the market, having an attractive combination of design features such as self-alignment and very high load carrying capacity – features that make them irreplaceable in many demanding applications.

Sealed SKF Explorer spherical roller bearings have the same internal design as their open counterparts and have additional important features, distinct for both machine designers and end users.

Reduced need for maintenance

Sealed SKF Explorer spherical roller bearings are ready-to-use units that are filled, under clean conditions, at the factory with a proper amount of the correct grease. The bearings can extend service life considerably due to the cleanliness in the bearing cavity. As a result, many applications can be considered virtually maintenance-free.

Increased uptime and reliability

Cleanliness in a bearing is essential for long service life. Even very small particles can have a negative influence. By using sealed spherical roller bearings instead of open bearings, solid contaminants and moisture can be efficiently stopped from entering the bearing.

Grease savings

Contact seals on both sides of a bearing will keep grease where it is needed the most – inside the bearing.

In many cases, the grease service life is actually longer than the service life of the bearing or the application, making relubrication unnecessary.

Compact bearing arrangements

Sealed spherical roller bearings are especially suitable for bearing arrangements where, because of limited space or for cost reasons, effective external seals are not practical. The favourable design characteristics enable axial downsizing and therefore a more efficient and compact machine design.

Environmentally friendly

By reducing grease consumption, users of sealed spherical roller bearings can reduce the cost of buying and disposing of grease. But more importantly, these bearings can reduce the environmental impact that a machine will have while in service.



Enhanced efficiency in most industrial segments

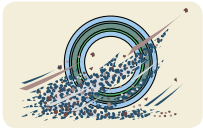

Reliable

Sealed SKF Explorer spherical roller bearings provide a high degree of reliability in the most demanding applications. The integral seals retain the grease and protect the bearing from the ingress of contaminants during handling, mounting, and operation.

Industrial segments

- Metallurgy
- Mining and construction
- Fluid machinery
- Material handling
- Industrial gearboxes
- Textile industry
- Railways
- Energy

Typical customer requirements

- Long service life
- High load carrying capacity
- Compact arrangements
- Accommodate misalignment
- Minimum maintenance
- Low operating costs
- Few unplanned stops
- Environmental sustainability
- High availability
- Technical support

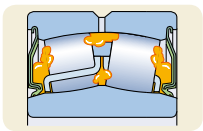

Lubricated

Bearings for normal operating temperatures and speeds are lubricated with SKF LGEP 2, a grease with a lithium thickener. The grease has excellent rust inhibiting properties.

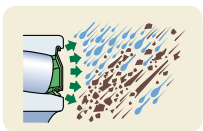

Protected

The bearings are fitted with a double-lip seal on both sides. The seals are made of either acrylonitrile-butadiene rubber (NBR) or hydrogenated acrylonitrile-butadiene rubber (HNBR) and reinforced with sheet steel.





Selection of bearing size

Bearing life

The life-extending features embodied in sealed SKF Explorer spherical roller bearings can best be understood using the SKF rating life equation in accordance with ISO 281:1990/Amd 2:2000. The life can be expressed in

$$L_{nm} = a_1 a_{SKF} L_{10}$$

using the equation:

$$L_{nm} = a_1 a_{SKF} \left(\frac{C}{P} \right)^{10/3}$$

If the speed is constant, the life can best be expressed in operating hours using the equation:

$$L_{nmh} = a_1 a_{SKF} \frac{1\,000\,000}{60n} \left(\frac{C}{P} \right)^{10/3}$$

where

- L_{nm} = SKF rating life at (100 – n)% reliability [millions of revolutions]¹⁾
- L_{nmh} = SKF rating life at (100 – n)% reliability [operating hours]¹⁾
- L_{10} = basic rating life at 90% reliability [millions of revolutions]
- a_1 = life adjustment factor for reliability (→ **table 1**)
- a_{SKF} = SKF life modification factor (→ **diagram 1**)
- C = basic dynamic load rating [kN]
- P = equivalent dynamic bearing load [kN]
- n = rotational speed [r/min]

The a_{SKF} factor

The a_{SKF} factor represents a very complex relationship between various influencing factors: the fatigue load limit ratio, contamination and lubrication. Values of the fatigue load limit (P_U) are provided in the product tables. Lubrication conditions are expressed by the viscosity ratio κ . Values of a_{SKF} can be obtained from **diagram 1** for different values of k and the expression $\eta_c (P_U/P)$.

Diagram 1 includes a safety factor commonly used in fatigue life considerations and is valid for lubricants without EP additives. If a lubricant containing such additives is used, refer to the *SKF General Catalogue* or online at www.SKF.com.

Equivalent dynamic bearing load

The equivalent dynamic bearing load for spherical roller bearings can be obtained from

$$P = F_r + Y_1 F_a \text{ when } F_a/F_r \leq e$$

$$P = 0,67 F_r + Y_2 F_a \text{ when } F_a/F_r > e$$

where

- P = equivalent dynamic bearing load [kN]
- F_r = radial component of the bearing load [kN]
- F_a = axial component of the bearing load [kN]
- Y_1, Y_2 = axial load factors for the bearings
- e = calculation factor

Appropriate values for the factors e, Y_1 and Y_2 can be found in the product tables for each individual bearing.

Table 1

Values for life adjustment factor a_1

Reliability %	Failure probability $n^1)$ %	SKF rating life L_{nm}	Factor a_1
90	10	L_{10m}	1
95	5	L_{5m}	0,62
96	4	L_{4m}	0,53
97	3	L_{3m}	0,44
98	2	L_{2m}	0,33
99	1	L_{1m}	0,21

¹⁾ The factor n , to calculate L_{nm} and L_{nmh} represents the failure probability, i.e. the difference between the requisite reliability and 100%

Sealed versus open spherical roller bearings – a comparison

The performance enhancements incorporated into sealed SKF Explorer spherical roller bearings can best be demonstrated by comparing the calculated bearing life of a sealed spherical roller bearing BS2-2218-2CS/VT143 with a comparable open bearing 22218 E.

Both bearings have the same basic dynamic load rating C and fatigue load limit P_u .

$$C = 325 \text{ kN}$$

$$P_u = 39 \text{ kN}$$

The operating conditions are:

- Equivalent dynamic bearing load $P = 28,2 \text{ kN}$
- Viscosity ratio $\kappa = 2$
- Contamination factor $\eta_c = 0,7$ for the sealed bearing (→ **table 2**).
- Contamination factor $\eta_c = 0,4$ for the open bearing (→ **table 2**).

Life calculation for the sealed bearing:

Insert $\eta_c (P_u/P) = 0,7 \times 39/28,2 = 0,96$ on the horizontal scale in **diagram 1**. Move vertically to the intersection with the $\kappa = 2$ curve. This gives $a_{SKF} \approx 30,9$.

$$L_{10m} = a_{SKF}(C/P)^{10/3} = 3,09 \times (325/28,2)^{10/3}$$

$$L_{10m} = 106\,800 \text{ million revolutions}$$

Life calculation for the open bearing:

Insert $\eta_c (P_u/P) = 0,4 \times 39/28,2 = 0,55$ on the horizontal scale in **diagram 1**. Move vertically to the intersection with the $\kappa = 2$ curve. This gives $a_{SKF} \approx 7,1$.

$$L_{10m} = a_{SKF}(C/P)^{10/3} = 7,1 \times (325/28,2)^{10/3}$$

$$L_{10m} = 24\,500 \text{ million revolutions}$$

In this case, the rating life ratio between equivalent sealed and open bearings results in $106\,800/24\,500 = 4,4$. In other words, the life of the sealed bearing is more than four times longer than that of the open bearing.

Table 2

Guideline values for factor η_c for different levels of contamination

Condition	Factor η_c ¹⁾ for bearings with diameter	
	$d_m < 100 \text{ mm}$	$d_m \geq 100 \text{ mm}$
Extreme cleanliness Particle size of the order of the lubricant film thickness. Laboratory conditions	1	1
High cleanliness Oil filtered through an extremely fine filter. Conditions typical of relubrication-free sealed bearings	0,8 ... 0,6	0,9 ... 0,8
Normal cleanliness Oil filtered through a fine filter. Conditions typical of bearings greased for life and sealed	0,6 ... 0,5	0,8 ... 0,6
Slight contamination Slight contamination of the lubricant	0,5 ... 0,3	0,6 ... 0,4
Typical contamination Typical conditions for bearings without integral seals, where contamination levels are normal	0,3 ... 0,1	0,4 ... 0,2
Severe contamination Bearing environment heavily contaminated and bearing arrangement with inadequate sealing	0,1 ... 0	0,1 ... 0
Very severe contamination Under extreme contamination, values of η_c can be outside the scale resulting in a more severe reduction of life than predicted by the equation for L_{nm}	0	0

¹⁾ The scale for η_c refers only to solid contaminants. Water or other fluid contaminants detrimental to bearing service life are not included. In highly contaminated environments ($\eta_c = 0$), the bearing will fail prematurely due to excessive wear and will not attain the calculated bearing life.

Diagram 1

Factor a_{SKF} for SKF Explorer radial roller bearings

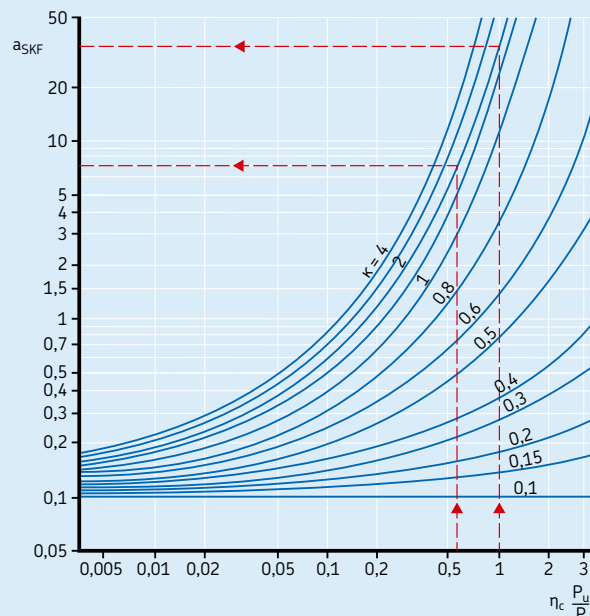

Bearing arrangement design

Abutment dimensions

Part of the range of sealed SKF spherical roller bearings have an extended width compared to corresponding open bearings. These bearings cannot replace standard open bearings without modifying the associated components in the application.

Due to the tapered seal land, the face diameter d_2 is smaller in sealed bearings than in corresponding open bearings (→ Product tables). When determining an abutment diameter d_a , the lower d_2 value for the sealed bearings must be taken into consideration (→ fig. 1).

Bearing space considerations

Sealed SKF spherical roller bearings are designed in such a way that the seals are positioned inside the side face plane. However, care must be taken so that nothing in the housing or on the shaft can interfere with the bearing seals during operation.

In applications where relubrication is necessary, there must be sufficient axial space (→ fig. 1) for the grease to purge through the seals. The axial space should be at least 10 times the maximum radial internal clearance value for the selected bearing (→ table 1, page 11).

The SKF three-barrier solution

The SKF three-barrier solution, which comprises a sealed spherical roller bearing, a housing with a 70 to 90% grease fill, and external labyrinth seals (→ fig. 2), is a very efficient sealing solution. Bearing arrangements with open bearings and contact seals can actually generate more friction than the SKF three-barrier solution. Using a sealed spherical roller bearing also means that the barrier grease used for filling the housing and the labyrinth seals is independent of the lubrication prerequisites of the bearing. Biodegradable greases can therefore be used. For additional information about the SKF three-barrier solution, contact the SKF Application engineering service.

IMPORTANT: There must be axial free space in the housing of a non-locating bearing or the bearing will be unable to move.

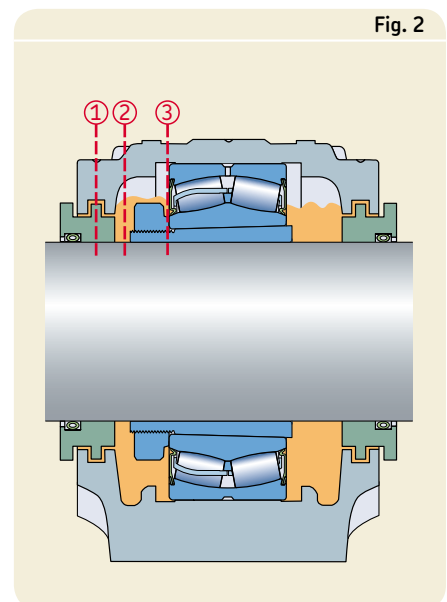
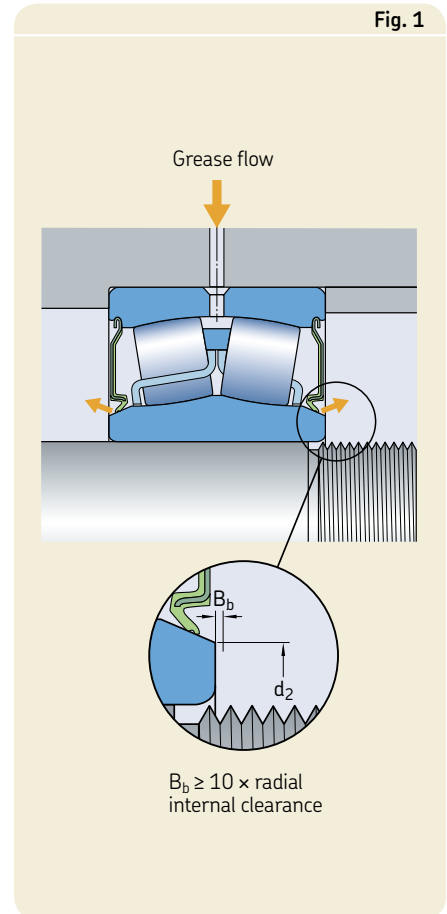

Lubrication

The sealed spherical roller bearings shown in the product tables have, with two exceptions, an annular groove and three lubrication holes as standard. To prevent the ingress of contaminants, and to retain the grease in the bearing, a polymer band in the groove covers the lubrication holes of some smaller bearings (→ **page 13**).

If it is anticipated that bearing relubrication will be necessary during operation, the band should be removed before the bearing is mounted (→ **fig. 1**). When relubricating, grease should be applied slowly and with low pressure to the bearing as it rotates until fresh grease emerges from the sealing lips. Excess pressure should be avoided to prevent seal damage.

For additional information, see the *SKF Interactive Engineering Catalogue* online at www.skf.com/bearings.

Relubrication intervals

The same relubrication intervals should be used for sealed as for open bearings.

Because of their internal design, sealed SKF spherical roller bearings are able to accommodate heavy axial loads. However, if $F_a/F_r > e$ (→ product tables), more frequent relubrication is recommended.

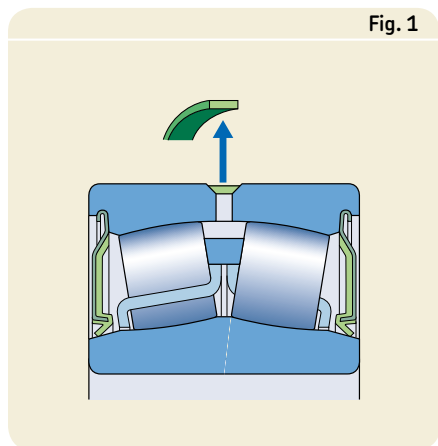

Grease quantity for relubrication

Suitable quantities for replenishment can be obtained from

$$G_p = 0,0015 D B$$

where

G_p = grease quantity to be added when replenishing, g

D = bearing outside diameter, mm

B = bearing width, mm

The rule of thumb for maintenance-free

For general purpose applications categorized according to the *General Catalogue 6000*, **page 72**:

- used 8 hours per day but not always fully utilized,
- normal operating conditions,
- horizontal shaft,

the bearing can be considered as virtually maintenance-free when

- the speed is less than 50% of the limiting speed, and
- the operating temperature does not exceed 70 °C (160 °F).

The green area in **diagram 1** illustrates the operating conditions where sealed spherical roller bearings are virtually maintenance-free.

Diagram 1

The maintenance-free rule of thumb – valid for bearings with standard grease (suffix VT143)

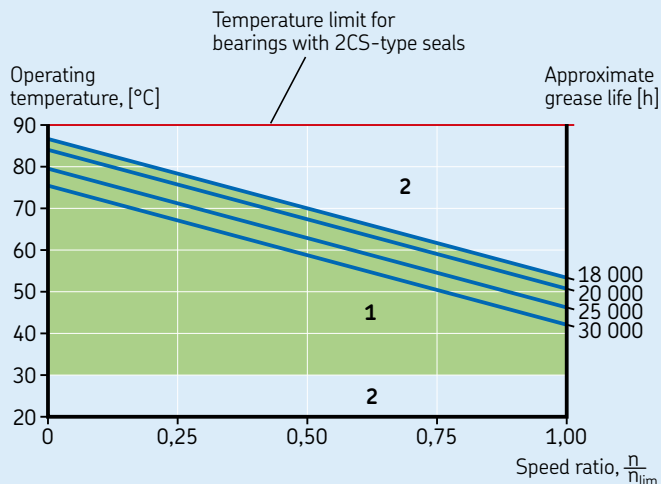

- 1 Application area where bearings are virtually maintenance-free.
- 2 Application area where, based on certain specific conditions, bearings can be considered virtually maintenance-free.

Mounting and dismounting

Mounting

When mounting sealed spherical roller bearings it is important not to subject the bearings to excessive misalignment. If there is a considerable moment load imposed on the seals via the rollers or cages, there is a risk that the seals may be dislodged or damaged.

Bearings with a cylindrical bore

Sealed bearings with a cylindrical bore can be heated with an induction heater and hot mounted or pressed onto the shaft with a mounting dolly.

SKF does not recommend heating sealed bearings above 80 °C (175 °F). However, if higher temperatures are necessary, make sure that the temperature does not exceed the permissible temperature of either the seal or grease, whichever is lowest.

SKF does not recommend using a heating plate. However, if using a heating plate is unavoidable, the seal should not make contact with the plate. Appropriate distance washers should be used.

SKF recommends using KMFE lock nuts for the axial location of sealed spherical roller bearings (→ pages 13 to 15). These nuts provide the proper free space for the grease to escape when relubricating the bearings (→ fig. 1, page 8 and fig. 1). The alternative is to use a standard nut and lock washer. In this case, however, a spacer must be fitted between the lock washer and the inner ring. The width of the spacer has to match the axial free space condition, not to hinder the escape of grease (→ fig. 1, page 8).

Bearings with a tapered bore

When mounting sealed spherical roller bearings with a tapered bore, the expansion of the inner ring cannot be measured using feeler gauges.

Therefore, SKF recommends using the SKF Drive-up method for reliable and easy drive-up. General information is available at www.skf.com/mount.

If the SKF Drive-up method is not an option, the traditional drive-up method with a hook spanner and angle measurement is recommended. Additional information is available in the online library at www.skf.com.

Mounting on an adapter sleeve

Adapter sleeves facilitate mounting and dismounting and generally simplify the arrangement design (→ fig. 2a).

For bearings that need to be axially positioned, it is preferable to use a withdrawal sleeve (→ fig. 2b). However, if an adapter sleeve is to be used, it is preferable to use a support ring (→ fig. 2c).

Some bearings have a relatively small radial space for the support ring and should therefore not be subjected to a heavier axial load than the adapter sleeve can accommodate. (→ www.skf.com/bearings).

Note that the bore chamfer radius $r_{1,2min}$ for sealed spherical roller bearings with a tapered bore differs from bearings with a cylindrical bore. See page 12, table 2.

Dismounting

The general recommendations at www.skf.com/bearings are valid also for sealed spherical roller bearings.

If the sealed bearing is to be reused, care should be taken to avoid damaging the seal.

Fig. 1

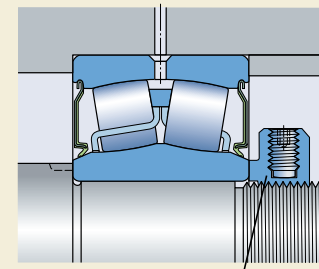

KMFE lock nut

Fig. 2

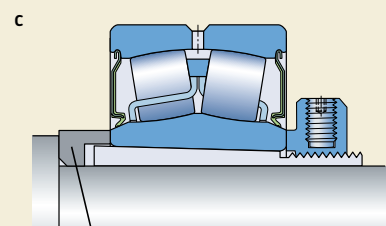
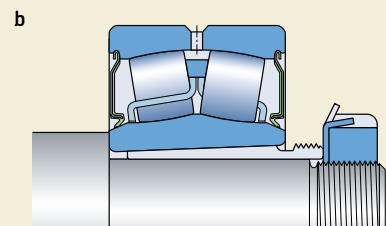
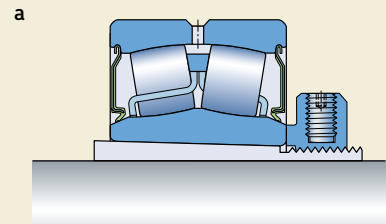

Support ring



Bearing data – general

Performance class

All sealed SKF spherical roller bearings belong to the SKF Explorer high performance class.

Cylindrical or tapered bore

Sealed SKF spherical roller bearings are available with either a cylindrical or tapered bore. The tapered bore is 1:12.

Annular groove and lubrication holes

To facilitate relubrication, all sealed SKF spherical roller bearings, with the exception of three sizes, have an annular groove and three lubrication holes in the outer ring, as standard.

Dimensions

The boundary dimensions of sealed SKF spherical roller bearings are in accordance with ISO 15:1998, except for the width of sealed bearings in the BS2- series.

Tolerances

Standard SKF spherical roller bearings are manufactured to a higher precision than the ISO Normal tolerances:

- The width tolerance is considerably tighter than the ISO Normal tolerance.
- The running accuracy is to P5 tolerance class.

Internal clearance

Standard sealed spherical roller bearings from SKF are manufactured with Normal radial internal clearance. Nearly all the bearings are also available with a larger C3 internal clearance and some can be supplied with an even larger C4 clearance. Some sizes are available with C2 internal clearance, which is smaller than Normal. Before ordering, contact SKF for availability of bearings with radial internal clearance other than Normal. The various radial internal clearances are in accordance with ISO 5753:1991 and listed in **table 1**. They are valid for zero measuring load prior to mounting.

Table 1

Radial internal clearance of sealed spherical roller bearings with a cylindrical bore

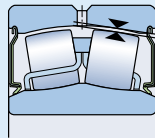

Radial internal clearance of spherical roller bearings with a tapered bore

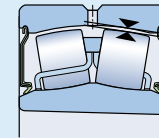

Bore diameter d		Radial internal clearance							
over	incl.	C2		Normal		C3		C4	
		min	max	min	max	min	max	min	max
mm		µm							
24	30	15	25	25	40	40	55	55	75
30	40	15	30	30	45	45	60	60	80
40	50	20	35	35	55	55	75	75	100
50	65	20	40	40	65	65	90	90	120
65	80	30	50	50	80	80	110	110	145
80	100	35	60	60	100	100	135	135	180
100	120	40	75	75	120	120	160	160	210
120	140	50	95	95	145	145	190	190	240
140	160	60	110	110	170	170	220	220	280
160	180	65	120	120	180	180	240	240	310
180	200	70	130	130	200	200	260	260	340
200	225	80	140	140	220	220	290	290	380
225	250	90	150	150	240	240	320	320	420
250	280	100	170	170	260	260	350	350	460
280	315	110	190	190	280	280	370	370	500
315	355	120	200	200	310	310	410	410	550
355	400	130	220	220	340	340	450	450	600

Bore diameter d		Radial internal clearance							
over	incl.	C2		Normal		C3		C4	
		min	max	min	max	min	max	min	max
mm		µm							
24	30	20	30	30	40	40	55	55	75
30	40	25	35	35	50	50	65	65	85
40	50	30	45	45	60	60	80	80	100
50	65	40	55	55	75	75	95	95	120
65	80	50	70	70	95	95	120	120	150
80	100	55	80	80	110	110	140	140	180
100	120	65	100	100	135	135	170	170	220
120	140	80	120	120	160	160	200	200	260
140	160	90	130	130	180	180	230	230	300
160	180	100	140	140	200	200	260	260	340
180	200	110	160	160	220	220	290	290	370
200	225	120	180	180	250	250	320	320	410
225	250	140	200	200	270	270	350	350	450
250	280	150	220	220	300	300	390	390	490
280	315	170	240	240	330	330	430	430	540
315	355	190	270	270	360	360	470	470	590
355	400	210	300	300	400	400	520	520	650

Misalignment

The design of sealed SKF spherical roller bearings is such that they are inherently self-aligning, i.e. the bearings can accommodate angular misalignment of the shaft relative to the housing without any negative effect on bearing performance.

Under operating conditions where the misalignment is constant relative to the outer ring, sealed SKF spherical roller bearings can accommodate angular misalignment of the shaft relative to the housing of up to $0,5^\circ$ with no detrimental effect on the efficiency of the seals.

When misalignment is not constant with respect to the bearing outer ring (\rightarrow fig. 1), the bearing friction increases and therefore the misalignment of the inner ring relative to the outer ring should not exceed a few tenths of a degree.

Influence of operating temperature on the bearing materials

The temperature that a sealed spherical roller bearing can accommodate is limited by the grease and seal material.

- Bearings with suffix 2CS/VT143 should not be used at operating temperatures above $+90^\circ\text{C}$ (194°F).
- Bearings with suffix 2CS2/VT143 or 2CS5/VT143 should not be used at operating temperatures above $+110^\circ\text{C}$ (230°F).

Axial load carrying capacity

Because of their internal design, sealed SKF spherical roller bearings are able to accommodate heavy axial loads. However, if $F_a/F_r > e$ (\rightarrow product tables), more frequent lubrication is recommended.

Speed ratings

The speed rating of sealed spherical roller bearings is limited by the friction generated in the seal contacts. Accordingly, only the limiting speed is listed in the product tables. The limiting speed for sealed spherical roller bearings is roughly 25% of the reference speed of open bearings.

Seal materials

Depending on the size, sealed SKF spherical roller bearings are fitted with seals made of one of the following materials:

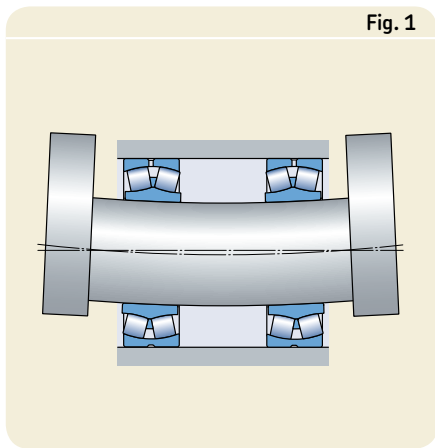

Table 2

Bore chamfer radii for bearings with a cylindrical bore or a tapered bore

Cylindrical bore $r_{1,2\min}$		Tapered bore $r_{1,2\min}$
1,0 to 1,1	\rightarrow	0,6
1,5 to 2,0	\rightarrow	1,0
2,1 to 3,0	\rightarrow	1,1
4,0	\rightarrow	1,5
5,0	\rightarrow	2,0
6,0	\rightarrow	3,0

- acrylonitrile-butadiene rubber (NBR), designation suffix CS
- hydrogenated acrylonitrile-butadiene rubber (HNBR), designation suffix CS5,
- fluoro-elastomer (FKM), designation suffix CS2. This material is being replaced by HNBR.

Supplementary data

A practical overview of the sealed bearing assortment including individual design differences, relubrication data and appropriate accessories, is shown in the supplementary data table on **page 13 to 15**.

The bore chamfer radius $r_{1,2\min}$ listed in the product table is valid for bearings with a cylindrical bore. The corresponding values for bearings with a tapered bore are listed in **table 2**.

Designations

There are two designation modes for sealed SKF Explorer spherical roller bearings. See overview on **page 16 to 17**.

WARNING!

Safety precautions for fluoro rubber

Fluoro rubber is very stable and harmless under normal operating conditions up to $+200^\circ\text{C}$. However, if exposed to extreme temperatures above 300°C , e.g. fire or the flame of a cutting torch, fluoro rubber seals give off hazardous fumes. These fumes can be harmful if inhaled, as well as to the eyes. In addition, once the seals have been heated to such temperatures, they are dangerous to handle even after they have cooled and should not be in contact with the skin. If it is necessary to handle bearings with seals that have been subjected to high temperatures, such as when dismounting the bearing, the following safety precautions should be observed:

- Always wear protective goggles, gloves and an appropriate breathing apparatus.
- Place the remains of the seals in an airtight plastic container marked with a symbol for "material will etch".
- Follow the safety precautions in the appropriate material safety data sheet (MSDS).

If there is unintentional contact with the seals, wash hands with soap and plenty of water and flush eyes with plenty of water and consult a doctor immediately. If the fumes have been inhaled, consult a doctor immediately.

The user is responsible for the correct use of the product during its service life and its proper disposal. SKF takes no responsibility for the improper handling of fluoro rubber seals or for any injury resulting from their use.

Supplementary data

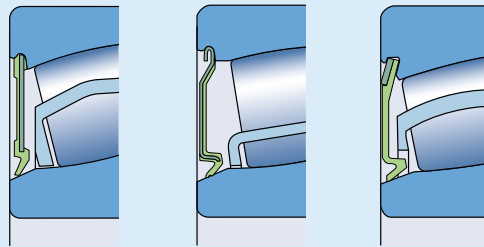

Seal type

1

2

3

Bearing designation	Seal type	Standard seal material	Standard relubrication features ¹⁾	Free space in bearing cm ³	Appropriate adapter sleeve incl. lock nut	Appropriate locating rings, FRB ²⁾
–	–	–	–	–	–	–
BS2-2205-2CS/VT143	1	NBR	W33+RB	5,5	–	–
BS2-2206-2CS/VT143	1	NBR	W33+RB	8	–	–
BS2-2207-2CS/VT143	1	NBR	W33+RB	13	–	–
BS2-2208-2CS(K)/VT143	2	NBR	W33+RB	18	H 2308 E	5.5/80
BS2-2308-2CS/VT143	2	NBR	W33+RB	34	–	–
BS2-2209-2CS(K)/VT143	2	NBR	W33+RB	20	H 309 E	1/85
BS2-2309-2CS/VT143	2	NBR	W33+RB	47	–	–
BS2-2210-2CS(K)/VT143	2	NBR	W33+RB	21	H 310 E	6.5/90
BS2-2310-2CS/VT143	2	NBR	W33+RB	60	–	–
BS2-2211-2CS(K)/VT143	2	NBR	W33+RB	29	H 311 E	6.5/100
BS2-2311-2CS/VT143	2	NBR	W33+RB	78	–	–
BS2-2212-2CS(K)/VT143	2	NBR	W33+RB	41	H 312 E	7/110
BS2-2312-2CS/VT143	2	NBR	W33+RB	99	–	–
24013-2CS5W/VT143	2	HNBR	–	26	–	–
BS2-2213-2CS(K)/VT143	2	NBR	W33+RB	48	H 2313 E	6.5/120
BS2-2313-2CS/VT143	2	NBR	W33+RB	120	–	–
BS2-2214-2CS(K)/VT143	2	NBR	W33+RB	57	H 314 E	–
BS2-2314-2CS/VT143	2	NBR	W33+RB	148	–	–
24015-2CS2W/VT143	2	FKM	–	33	–	–
BS2-2215-2CS(K)/VT143	2	NBR	W33+RB	62	H 315 E	9/130
BS2-2315-2CS/VT143	2	NBR	W33+RB	180	–	–
BS2-2216-2CS(K)/VT143	2	NBR	W33+RB	74	H 316 E	9/140
BS2-2316-2CS/VT143	2	NBR	W33+RB	210	–	–
BS2-2217-2CS(K)/VT143	2	NBR	W33+RB	95	H 317 E	8.5/150
BS2-2218-2CS(K)/VT143	2	NBR	W33+RB	120	H 2318 E/L73	8.5/160
23218-2CS/VT143	2	NBR	W33	100	H 2318 EL	6.25/160
BS2-2219-2CS(K)/VT143	2	NBR	W33+RB	145	H 2319 EL	8.5/170
24020-2CS2/VT143	2	FKM	W33	60	–	–
23120-2CS2/VT143	2	FKM	W33	87	–	–
24120-2CS5/VT143	3	HNBR	W33	180	–	–
BS2-2220-2CS5(K)/VT143	3	HNBR	W33	185	H 2320 E	7.5/180
23220-2CS/VT143	3	NBR	W33	145	–	4.85/180
23022-2CS/VT143	3	NBR	W33	96	–	–

¹⁾ RB = Rubber band

²⁾ FRB = Locating ring in SNL housings

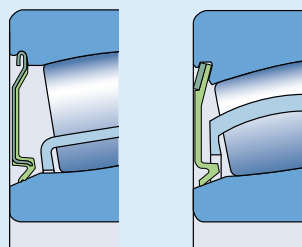

Seal type

2

3

Bearing designation	Seal type	Standard seal material	Standard relubrication features ¹⁾	Free space in bearing cm ³	Appropriate adapter sleeve incl. lock nut	Appropriate locating rings, FRB ²⁾
–	–	–	–	cm ³	–	–
24022-2CS5/VT143	2	HNBR	W33	100	–	–
23122-2CS5(K)/VT143	3	HNBR	W33	165	H 3122 E	–
24122-2CS5/VT143	3	HNBR	W33	225	–	–
BS2-2222-2CS5(K)/VT143	3	HNBR	W33	250	H 2322 E	8.5/200
23222-2CS5(K)/VT143	3	HNBR	W33	250	H 2322 E	5.1/200
23024-2CS2/VT143	3	FKM	W33+RB	90	–	–
24024-2CS5/VT143	3	HNBR	W33	135	–	–
24124-2CS5/VT143	3	HNBR	W33	305	–	–
BS2-2224-2CS5(K)/VT143	3	HNBR	W33	290	H 2324 EH	8.5/215
23224-2CS5(K)/VT143	3	HNBR	W33	310	H 2324 L	5/215
22324-2CS5(K)/VT143	3	HNBR	W33	630	H 2324	–
23026-2CS5/VT143	3	HNBR	W33	170	H 3026 E	–
24026-2CS5/VT143	3	HNBR	W33	200	–	–
24126-2CS5/VT143	3	HNBR	W33	325	–	–
BS2-2226-2CS5(K)/VT143	3	HNBR	W33	390	H 2326 L	7.5/230
23226-2CS5(K)/VT143	3	HNBR	W33	375	H 2326 L	5/230
22326-2CS5(K)/VT143	3	HNBR	W33	760	H 2326	–
23028-2CS5(K)/VT143	3	HNBR	W33	180	H 3028 E	–
24028-2CS5/VT143	3	HNBR	W33	210	–	–
24128-2CS5/VT143	3	HNBR	W33	395	–	–
22228-2CS5(K)/VT143	3	HNBR	W33	400	H 3128 L	15/250
23228-2CS5(K)/VT143	3	HNBR	W33	530	H 2328	5/250
22328-2CS5(K)/VT143	3	HNBR	W33	950	H 2328	–
23030-2CS5(K)/VT143	3	HNBR	W33	215	H 3030 E	–
24030-2CS5/VT143	3	HNBR	W33	265	–	–
23130-2CS5(K)/VT143	3	HNBR	W33	405	H 3130 E	–
24130-2CS2/VT143	3	FKM	W33	595	–	–
22230-2CS5(K)/VT143	3	HNBR	W33	495	H 3130	16.5/270
23230-2CS5/VT143	3	HNBR	W33	780	H 2330	5/270
22330-2CS5(K)/VT143	3	HNBR	W33	1 100	H 2330	–
23032-2CS5 (K)/VT143	3	HNBR	W33	265	H 3032 E	–
24032-2CS5/VT143	3	HNBR	W33	320	–	–
23132-2CS5(K)/VT143	3	HNBR	W33	590	H 3132 E	–
24132-2CS5/VT143	3	HNBR	W33	690	–	–
22232-2CS5 (K)/VT143	3	HNBR	W33	785	H 3132	17/290
22332-2CS5(K)/VT143	3	HNBR	W33	1 320	H 2332	–
23034-2CS5 (K)/VT143	3	HNBR	W33	335	H 3034 E	–
24034-2CS5/VT143	3	HNBR	W33	505	–	–
23134-2CS5 (K)/VT143	3	HNBR	W33	610	H 3134 E	–

¹⁾ RB = Rubber band

²⁾ FRB = Locating ring in SNL housings

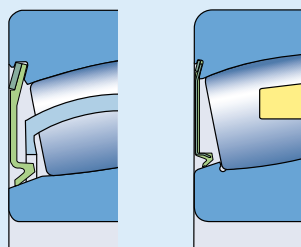

Seal type

3

4

Bearing designation	Seal type	Standard seal material	Standard relubrication features	Free space in bearing cm ³	Appropriate adapter sleeve incl. lock nut	Appropriate locating rings, FRB
-	-	-	-	cm ³	-	-
24134-2CS5/VT143	3	HNBR	W33	805	-	-
22234-2CS5 (K)/VT143	3	HNBR	W33	935	H 3134	-
23036-2CS5 (K)/VT143	3	HNBR	W33	465	H 3036 E	-
24036-2CS5/VT143	3	HNBR	W33	575	-	-
23136-2CS5 (K)/VT143	3	HNBR	W33	750	H 3136 L	-
24136-2CS5/VT143	3	HNBR	W33	880	-	-
22236-2CS5 (K)/VT143	3	HNBR	W33	830	H 3136	-
23138-2CS5/VT143	3	HNBR	W33	840	H 3138	-
24138-2CS5 (K)/VT143	3	HNBR	W33	1 250	-	-
22238-2CS5 (K)/VT143	3	HNBR	W33	1 050	H 3138	-
23040-2CS5 (K)/VT143	3	HNBR	W33	650	H 3040	-
23140-2CS5 (K)/VT143	3	HNBR	W33	1 050	H 3140	-
24140-2CS5/VT143	3	HNBR	W33	1 550	-	-
22240-2CS5 (K)/VT143	3	HNBR	W33	1 200	H 3140	-
23240-2CS5 (K)/VT143	3	HNBR	W33	1 800	H 2340 L	-
23044-2CS5 (K)/VT143	3	HNBR	W33	850	OH 3044 H	-
23144-2CS5 (K)/VT143	3	HNBR	W33	1 300	OH 3144 HTL	-
23944-2CS5/VT143	3	HNBR	W33	370	-	-
22244-2CS5 (K)/VT143	3	HNBR	W33	1 650	OH 3144 H	-
22344-2CS5 (K)/VT143	3	HNBR	W33	3 200	OH 2344 H	-
23048-2CS5 (K)/VT143	3	HNBR	W33	920	OH 3048 HE	-
23148-2CS5 (K)/VT143	3	HNBR	W33	1 650	OH 3148 HTL	-
23052-2CS5 (K)/VT143	3	HNBR	W33	1 350	OH 3052 HE	-
23152-2CS5 (K)/VT143	3	HNBR	W33	2 700	OH 3152 HTL	-
23156-2CS5 (K)/VT143	3	HNBR	W33	2 500	OH 3156 HTL	-
23160-2CS5 (K)/VT143	3	HNBR	W33	3 200	OH 3160 HE	-
23164-2CS5(K)/VT143	3	HNBR	W33	3 900	OH 3164 H	-
23168-2CS5(K)/VT143	3	HNBR	W33	5 300	OH 3168 HE	-
23172-2CS5(K)/VT143	3	HNBR	W33	6 100	OH 3172 HE	-
23180-2CS5(K)/VT143	4	HNBR	W33	6 800	OH 3180 HE	-

Designations

There are two designation modes for sealed SKF Explorer spherical roller bearings. One identifies sealed bearings in the standard ISO dimension series. The other mode identifies sealed bearings that are wider than the ISO specification.

Bearings with principal dimensions according to ISO standard (Example: 24026-2CS5/VT143)

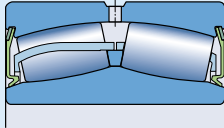

xxxxx-2CSx/xxxx

Basic designation

Standard five-digit basic designation as for open bearings.

Seals

2CS

Acrylonitrile-butadiene rubber (NBR) seal on both sides.

2CS5

Outer ring with relubrication features. Hydrogenated acrylonitrile-butadiene rubber (HNBR) seal on both sides.

2CS2

Outer ring with relubrication features. Fluoroelastomer (FKM) seal on both sides. **WARNING:** See safety message on page 12. Outer ring with relubrication features.

Lubricant

VT143

Filled to 25 to 45% with LGEP 2 grease. See also *Supplementary suffixes*.

Bearings with extended width (Example: BS2-2222-2CS5/VT143)

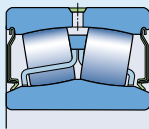

BS2-xxxx-2CSx/xxxx

Basic designation

Spherical roller bearing with two rows of rollers. The two initial digits denote the dimension series and the two last digits the bore diameter divided by 5.

Seals

2CS

Acrylonitrile-butadiene rubber (NBR) seal on both sides.

2CS5

Outer ring with relubrication features. Hydrogenated acrylonitrile-butadiene rubber (HNBR) seal on both sides.

2CS2

Outer ring with W33 groove and holes. Fluoroelastomer (FKM) seal on both sides. **WARNING:** See safety message on page 12. Outer ring with W33 groove and holes.

Lubricant

VT143

Filled to 25 to 45% with LGEP 2 grease. See also *Supplementary suffixes*.

Suffixes in product tables

2CS	Bearing sealed on both sides. Seal material: Acrylonitrile-butadiene rubber (NBR). Outer ring with W33 groove and holes.
2CS2	Bearing sealed on both sides. Seal material: Fluoroelastomer (FKM). Outer ring with W33 groove and holes.
2CS5	Bearing sealed on both sides. Seal material: Hydrogenated acrylonitrile-butadiene rubber (HNBR). Outer ring with W33 groove and holes.
K	Tapered bore. Taper 1:12
VT143	Filled to 25 to 45% with LGEP 2 grease. The filling degree depends on bearing size.
W	Bearing without W33 groove and holes in the outer ring.

Supplementary suffixes

CS	Bearing sealed on one side Seal material: Acrylonitrile-butadiene rubber (NBR) Outer ring with W33 groove and holes
CS5	Bearing sealed on one side Seal material: Hydrogenated acrylonitrile-butadiene rubber (HNBR). Outer ring with W33 groove and holes
C3	Radial internal clearance greater than Normal
C4	Radial internal clearance greater than C3
GEM9	Filled to 70 to 100% with LGHB 2 grease
VT143B	Filled to 45 to 60% with LGEP 2 grease
VT143C	Filled to 70 to 100% with LGEP 2 grease



Former versus new suffixes

Former suffix		New suffix
xxxxx-2CS (Grease specification included in the 2CS suffix)	replaced by	xxxxx-2CS/VT143 (Grease specification not included in the 2CS suffix. Instead it is included in the VT143 suffix)
xxxxx-2CS5 (Grease specification included in the 2CS5 suffix)	replaced by	xxxxx-2CS5/GEM9 (Grease specification not included in the 2CS5 suffix. Instead it is included in the GEM9 suffix)

Sealed SKF Explorer spherical roller bearings

d 25 – 95 mm

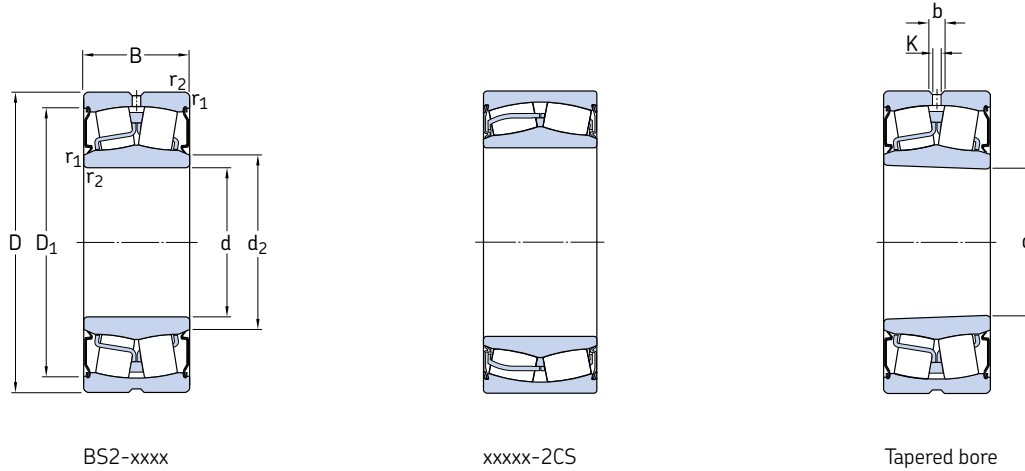

Principal dimensions			Basic load ratings		Fatigue load limit P_u	Limiting speed	Mass	Designations Bearings with cylindrical bore	Bearings with tapered bore
d	D	B	C	C_0					
mm			kN		kN	r/min	kg	–	
25	52	23	49	44	4,75	3 600	0,26	BS2-2205-2CS/VT143	–
30	62	25	64	60	6,4	2 800	0,34	BS2-2206-2CS/VT143	–
35	72	28	86,5	85	9,3	2 400	0,52	BS2-2207-2CS/VT143	–
40	80	28	96,5	90	9,8	2 200	0,57	BS2-2208-2CS/VT143	BS2-2208-2CSK/VT143
	90	38	150	140	15	1 900	1,2	BS2-2308-2CS/VT143	–
45	85	28	102	98	10,8	2 000	0,66	BS2-2209-2CS/VT143	BS2-2209-2CSK/VT143
	100	42	183	183	19,6	1 500	1,6	BS2-2309-2CS/VT143	–
50	90	28	104	108	11,8	1 900	0,7	BS2-2210-2CS/VT143	BS2-2210-2CSK/VT143
	110	45	220	224	24	1 400	2,1	BS2-2310-2CS/VT143	–
55	100	31	125	127	13,7	1 700	1	BS2-2211-2CS/VT143	BS2-2211-2CSK/VT143
	120	49	270	280	30	1 400	2,8	BS2-2311-2CS/VT143	–
60	110	34	156	166	18,6	1 600	1,3	BS2-2212-2CS/VT143	BS2-2212-2CSK/VT143
	130	53	310	335	36,5	1 100	3,4	BS2-2312-2CS/VT143	–
65	100	35	132	173	20,4	1 200	0,95	24013-2CS5W/VT143	–
	120	38	193	216	24	1 500	1,6	BS2-2213-2CS/VT143	BS2-2213-2CSK/VT143
	140	56	340	360	38	1 000	4,15	BS2-2313-2CS/VT143	–
70	125	38	208	228	25,5	1 400	1,8	BS2-2214-2CS/VT143	BS2-2214-2CSK/VT143
	150	60	400	430	45	900	5,1	BS2-2314-2CS/VT143	–
75	115	40	173	232	28,5	1 000	1,55	24015-2CS2W/VT143	–
	130	38	212	240	26,5	1 300	2,1	BS2-2215-2CS/VT143	BS2-2215-2CSK/VT143
	160	64	440	475	48	950	6,5	BS2-2315-2CS/VT143	–
80	140	40	236	270	29	1 200	2,4	BS2-2216-2CS/VT143	BS2-2216-2CSK/VT143
	170	67	490	540	54	800	7,2	BS2-2316-2CS/VT143	–
85	150	44	285	325	34,5	1 100	3	BS2-2217-2CS/VT143	BS2-2217-2CSK/VT143
90	160	48	325	375	39	1 000	3,7	BS2-2218-2CS/VT143	BS2-2218-2CSK/VT143
	160	52,4	355	440	48	750	4,65	23218-2CS/VT143	–
95	170	51	380	450	46,5	950	4,65	BS2-2219-2CS/VT143	BS2-2219-2CSK/VT143

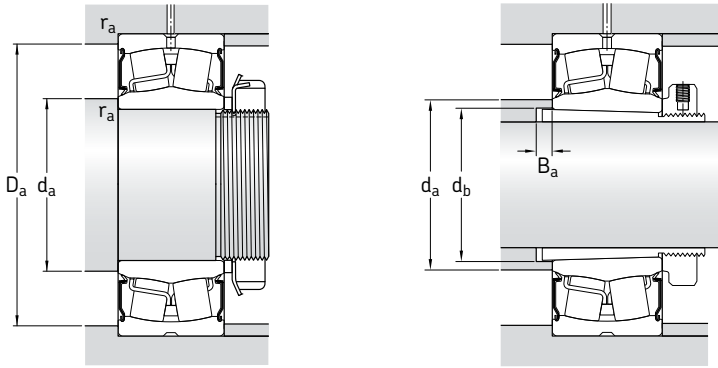

Dimensions

Abutment and fillet dimensions

Calculation factors

d	d ₂ ~	D ₁ ~	b	K	r _{1,2} ¹⁾ min	d _a min	d _a max	d _b min	B _a min	D _a max	r _a max	e	Y ₁	Y ₂	Y ₀
mm						mm						-			
25	30	47	3,7	2	1	30	30	-	-	46,4	1	0,35	1,9	2,9	1,8
30	36	55,7	3,7	2	1	35,6	36	-	-	56,4	1	0,31	2,2	3,3	2
35	43	63,7	3,7	2	1,1	42	43	-	-	65	1	0,31	2,2	3,3	2,2
40	47	73	5,5	3	1,1	47	47	44	8	73	1	0,28	2,4	3,6	2,5
	47,5	81	5,5	3	1,5	47,5	47,5	-	-	81	1,5	0,37	1,8	2,7	1,8
45	53	77,1	5,5	3	1,1	52	53	48,5	0	78	1	0,26	2,6	3,9	2,5
	55	89,1	5,5	3	1,5	54	55	50	6	81	1,5	0,37	1,8	2,7	1,8
50	58	82,1	5,5	3	1,1	57	58	53,5	2	83	1	0,24	2,8	4,2	2,8
	61,5	97,6	5,5	3	2	61	61,5	56	6	99	2	0,37	1,8	2,7	1,8
55	64	91,9	6	3	1,5	64	64	59	2	91	1,5	0,24	2,8	4,2	2,8
	67	109	5,5	3	2	66	67	61	6	109	2	0,35	1,9	2,9	1,8
60	69	102	6	3	1,5	69	69	64	1	101	1,5	0,24	2,8	4,2	2,8
	75	117,1	8,3	4,5	2,1	72	75	66	6	118	2	0,35	1,9	2,9	1,8
65	71,9	92,8	5,5	3	1,1	71	71,5	-	-	94	1	0,27	2,5	3,7	2,5
	76	111	5,5	3	1,5	74	76	70,5	14	111	1,5	0,24	2,8	4,2	2,8
	78,8	125,6	8,3	4,5	2,1	77	78,8	72	5	128	2	0,35	1,9	2,9	1,8
70	80	115	6	3	1,5	79	80	75	1	116	1,5	0,23	2,9	4,4	2,8
	86,8	136,1	8,3	4,5	2,1	82	86,8	76	6	138	2	0,33	2	3	2
75	81,5	105	5,5	-	-	81	81,5	-	-	109	1	0,28	2,4	3,6	2,5
	84	119	6	3	1,5	84	84	80	3	121	1,5	0,22	3	4,6	2,8
	88	144	8,3	4,5	2,1	87	88	82	5	148	2	0,35	1,9	2,9	1,8
80	91,5	128	6	3	2	91	91,5	85	2,5	129	2	0,22	3	4,6	2,8
	94,2	152,1	8,3	4,5	2,1	92	94,2	88	6	158	2	0,35	1,9	2,9	1,8
85	98	138	6	3	2	96	98	90	1,5	139	2	0,22	3	4,6	2,8
90	102	148	6	3	2	101	102	96,5	20,5	149	2	0,24	2,8	4,2	2,8
	104,5	147,1	5,5	3	2	101	104,5	-	-	149	2	0,31	2,2	3,3	2,2
95	109	157,1	8,3	4,5	2,1	107	109	105	23	158	2	0,24	2,8	4,2	2,8

¹⁾ Valid for bearings with a cylindrical bore only. Corresponding values for bearings with a tapered bore are listed on page 12, table 2.



Sealed SKF Explorer spherical roller bearings
d 100 – 140 mm

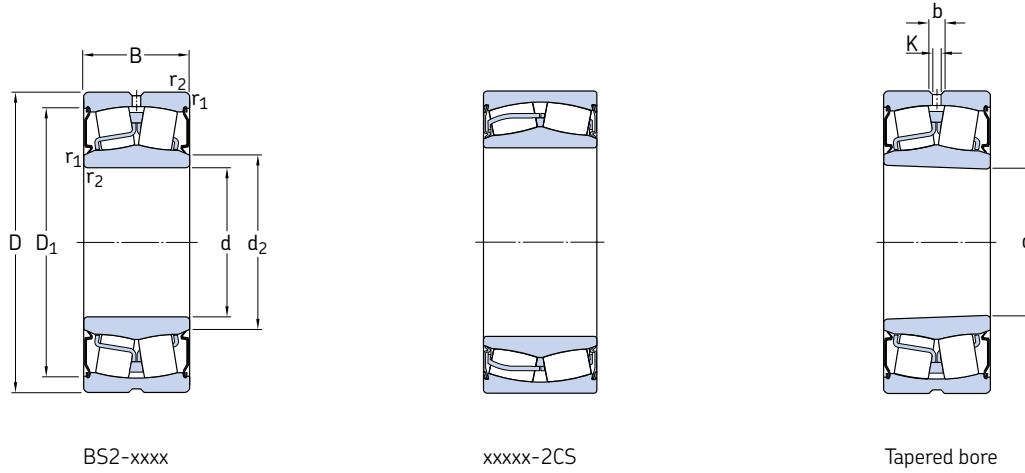

Principal dimensions			Basic load ratings		Fatigue load limit P_u	Limiting speed	Mass	Designations Bearings with cylindrical bore	Bearings with tapered bore
d	D	B	C	C_0					
mm			kN		kN	r/min	kg	–	
100	150	50	285	415	45,5	800	3,15	24020-2CS2/VT143	–
	165	52	365	490	53	850	4,55	23120-2CS2/VT143	–
	165	65	455	640	68	670	5,65	24120-2CS5/VT143	–
	180	55	425	490	49	900	5,35	BS2-2220-2CS5/VT143	BS2-2220-2CS5K/VT143
	180	60,3	475	600	63	700	6,85	23220-2CS/VT143	–
	110	170	45	310	440	46,5	900	3,8	23022-2CS/VT143
170		60	415	620	67	670	5	24022-2CS/VT143	–
180		56	430	585	61	800	5,75	23122-2CS5/VT143	23122-2CS5K/VT143
180		69	520	750	78	630	7,1	24122-2CS5/VT143	–
200		63	560	640	63	800	7,6	BS2-2222-2CS5/VT143	BS2-2222-2CS5K/VT143
200		69,8	600	765	76,5	640	9,85	23222-2CS5/VT143	23222-2CS5K/VT143
120	180	46	355	510	52	850	3,65	23024-2CS2/VT143	–
	180	60	430	670	68	670	5,45	24024-2CS5/VT143	–
	200	80	655	950	95	560	10,3	24124-2CS5/VT143	–
	215	69	630	765	73,5	750	9,75	BS2-2224-2CS5/VT143	BS2-2224-2CS5K/VT143
	215	76	695	930	93	600	12	23224-2CS5/VT143	23224-2CS5K/VT143
	260	86	980	1 120	100	600	23	22324-2CS5/VT143	22324-2CS5K/VT143
130	200	52	430	610	62	800	6	23026-2CS5/VT143	23026-2CS5K/VT143
	200	69	540	815	81,5	600	8,05	24026-2CS5/VT143	–
	210	80	680	1 000	100	530	11	24126-2CS5/VT143	–
	230	75	735	930	88	700	11	BS2-2226-2CS5/VT143	BS2-2226-2CS5K/VT143
	230	80	780	1060	104	530	14,5	23226-2CS5/VT143	23226-2CS5K/VT143
	280	93	1 120	1 320	114	500	29	22326-2CS5/VT143	22326-2CS5K/VT143
140	210	53	465	680	68	700	6,55	23028-2CS5/VT143	23028-2CS5K/VT143
	210	69	570	900	88	560	8,55	24028-2CS5/VT143	–
	225	85	765	1 160	112	450	13,5	24128-2CS5/VT143	–
	250	68	710	900	86,5	670	14	22228-2CS5/VT143	22228-2CS5K/VT143
	250	88	915	1 250	120	480	19	23228-2CS5/VT143	23228-2CS5K/VT143
	300	102	1 290	1 560	132	430	36,5	22328-2CS5/VT143	22328-2CS5K/VT143

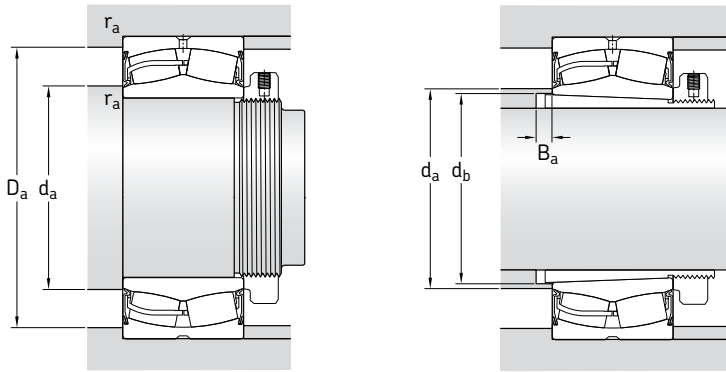

Dimensions						Abutment and fillet dimensions						Calculation factors			
d	d ₂	D ₁	b	K	r _{1,2} ¹⁾	d _a min	d _a max	d _b min	B _a min	D _a max	r _a max	e	Y ₁	Y ₂	Y ₀
mm						mm						-			
100	108	139	6	3	1,5	107	108	-	-	143	1,5	0,28	2,4	3,6	2,5
	112	152	6	3	2	111	112	-	-	154	2	0,27	2,5	3,7	2,5
	110	152	4,4	2	2	110	110	-	-	154	2	0,35	1,9	1,2	1,8
	114	162	8,3	4,5	2,1	112	114	107,5	22,5	168	2	0,24	2,8	4,2	2,8
	114	161	8,3	4,5	2,1	112	114	-	-	168	2	0,30	2,3	3,4	2,2
	110	157	6	3	2	119	122	-	-	161	2	0,23	2,9	4,4	2,8
110	121	157	5,5	3	2	119	121	-	-	161	2	0,33	2	3	2
	122	166	8,3	4,5	2	121	122	117	7	169	2	0,27	2,5	3,7	2,5
	121	163	6	3	2	121	121	-	-	169	2	0,35	1,9	2,9	1,8
	126	182	8,3	4,5	2,1	122	126	118	21,5	188	2	0,25	2,7	4	2,5
	126	178	8,3	4,5	2,1	122	126	121	17	188	2	0,33	2	3	2
	120	132	172	6	3	2	129	132	-	-	171	2	0,20	3,4	5
120	130	166	6	3	2	129	130	-	-	171	2	0,28	2,4	3,6	2,5
	132	179	6	3	2	131	132	-	-	189	2	0,37	1,8	2,7	1,8
	136	193	11,1	6	2,1	132	136	129	21,5	203	2	0,26	2,6	3,9	2,5
	137	193	8,3	4,5	2,1	132	137	131	17	203	2	0,33	2	3	2
	147	229	13,9	7,5	3	134	147	131	7	246	2,5	0,33	2	3	2
	130	145	186	8,3	4,5	2	139	145	137	8	191	2	0,21	3,2	4,8
130	140	183	6	3	2	139	140	-	-	191	2	0,30	2,3	3,4	2,2
	141	190	6	3	2	141	141	-	-	199	2	0,33	2	3	2
	147	205	11,1	6	3	144	147	139	23,5	216	2,5	0,27	2,5	3,7	2,5
	147	209	8,3	4,5	3	144	147	142	21	216	2,5	0,31	2,2	3,3	2,2
	159	246	16,7	9	4	147	159	142	8	263	3	0,33	2	3	2
	140	155	197	8,3	4,5	2	149	155	147	8	201	2	0,2	3,4	5
140	151	195	6	3	2	149	151	-	-	201	2	0,28	2,4	3,6	2,5
	153	203	8,3	4,5	2,1	152	153	-	-	213	2	0,35	1,9	2,9	1,8
	161	225	11,1	6	3	154	161	149	8	236	2,5	0,24	2,8	4,2	2,8
	161	225	11,1	6	3	154	161	152	22	236	2,5	0,33	2	3	2
	169	261	16,7	9	4	157	169	152	8	283	3	0,33	2	3	2

¹⁾ Valid for bearings with a cylindrical bore only. Corresponding values for bearings with a tapered bore are listed on page 12, table 2.

Sealed SKF Explorer spherical roller bearings
d 150 – 200 mm

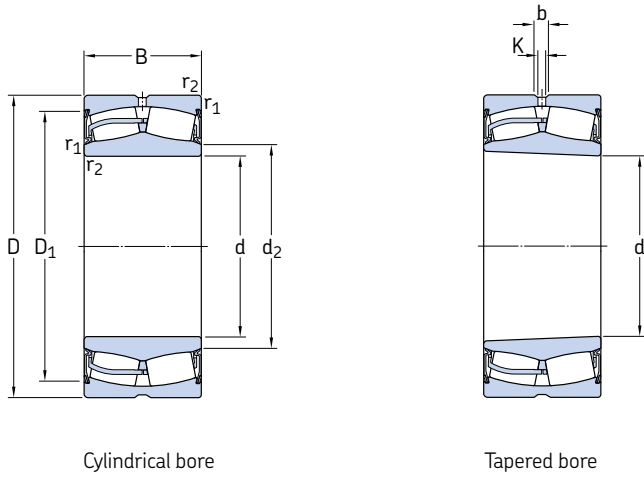

Principal dimensions			Basic load ratings		Fatigue load limit P_u	Limiting speed	Mass	Designations Bearings with cylindrical bore	Bearings with tapered bore
d	D	B	C	C_0					
mm			kN		kN	r/min	kg	–	
150	225	56	510	750	73,5	670	7,7	23030-2CS5/VT143	23030-2CS5K/VT143
	225	75	655	1 040	100	530	10,5	24030-2CS5/VT143	–
	250	80	850	1 200	114	560	16	23130-2CS5/VT143	23130-2CS5K/VT143
	250	100	1 020	1 530	146	400	20	24130-2CS5/VT143	–
	270	73	850	1 080	102	630	18	22230-2CS5/VT143	22230-2CS5K/VT143
	270	96	1 080	1 460	137	430	24,5	23230-2CS5/VT143	–
	320	108	1 460	1 760	146	400	43,5	22330-2CS5/VT143	22330-2CS5K/VT143
160	240	60	585	880	83	670	9,7	23032-2CS5/VT143	23032-2CS5K/VT143
	240	80	750	1 200	114	450	13	24032-2CS5/VT143	–
	270	86	980	1 370	129	530	20,5	23132-2CS5/VT143	23132-2CS5K/VT143
	270	109	1 200	1 760	163	380	25	24132-2CS5/VT143	–
	290	80	1 000	1 290	118	600	22,5	22232-2CS5/VT143	22232-2CS5K/VT143
	340	114	1 600	1 960	160	380	52	22332-2CS5/VT143	22332-2CS5K/VT143
170	260	67	710	1 080	100	630	13	23034-2CS5/VT143	23034-2CS5K/VT143
	260	90	930	1 460	137	400	17,5	24034-2CS5/VT143	–
	280	88	1 040	1 500	137	480	22	23134-2CS5/VT143	23134-2CS5K/VT143
	280	109	1 220	1 860	170	360	27,5	24134-2CS5/VT143	–
	310	86	1 120	1 460	134	500	28,5	22234-2CS5/VT143	22234-2CS5K/VT143
180	280	74	850	1 270	114	560	17	23036-2CS5/VT143	23036-2CS5K/VT143
	280	100	1 080	1 730	156	380	23	24036-2CS5/VT143	–
	300	96	1 200	1 800	160	430	28	23136-2CS5/VT143	23136-2CS5K/VT143
	300	118	1 400	2 160	196	360	34,5	24136-2CS5/VT143	–
	320	86	1 180	1 560	140	530	29,5	22236-2CS5/VT143	22236-2CS5K/VT143
190	320	104	1 400	2 080	183	400	35	23138-2CS5/VT143	23138-2CS5K/VT143
	320	128	1 600	2 500	212	340	43	24138-2CS5/VT143	–
	340	92	1 270	1 700	150	480	36,5	22238-2CS5/VT143	22238-2CS5K/VT143
200	310	82	1 000	1 530	137	480	23,3	23040-2CS5/VT143	23040-2CS5K/VT143
	340	112	1 600	2 360	204	380	43	23140-2CS5/VT143	23140-2CS5K/VT143
	340	140	1 800	2 800	232	320	53,5	24140-2CS5/VT143	–
	360	98	1 460	1 930	166	430	43,5	22240-2CS5/VT143	22240-2CS5K/VT143
	360	128	1 860	2 700	228	340	58	23240-2CS5/VT143	–

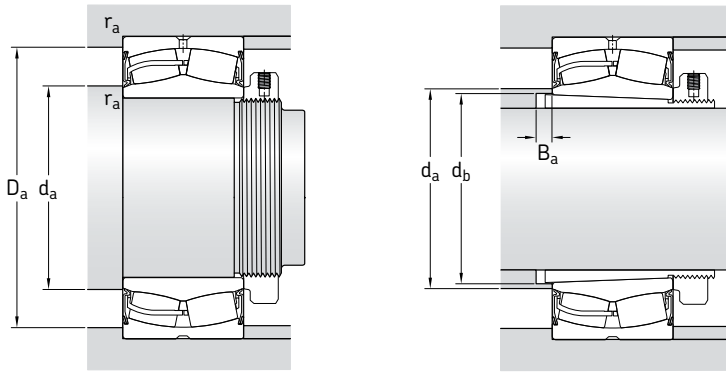

Dimensions						Abutment and fillet dimensions						Calculation factors				
d	d ₂	D ₁	b	K	r _{1,2} ¹⁾	d _a min	d _a max	d _b min	B _a min	D _a max	r _a max	e	Y ₁	Y ₂	Y ₀	
mm						mm						-				
150	165	211	8,3	4,5	2,1	161	165	158	8	214	2	0,2	3,4	5	3,2	
	162	206	6	3	2,1	161	162	-	-	214	2	0,28	2,4	3,6	2,5	
	168	226	11,1	6	2,1	162	168	160	8	238	2	0,28	2,4	3,6	2,5	
	163	222	8,3	4,5	2,1	162	163	-	-	238	2	0,37	1,8	2,7	1,8	
	174	248	13,9	7,5	3	164	174	160	15	256	2,5	0,24	2,8	4,2	2,8	
	171	243	11,1	6	3	164	171	163	20	256	2,5	0,33	2	3	2	
	181	281	16,7	9	4	167	181	163	8	313	3	0,33	2	3	2	
160	177	225	11,1	6	2,1	171	177	168	9	229	2	0,2	3,4	5	3,2	
	173	218	8,3	4,5	2,1	171	173	-	-	229	2	0,28	2,4	3,6	2,5	
	180	244	13,9	7,5	2,1	172	180	170	8	258	2	0,28	2,4	3,6	2,5	
	176	239	8,3	4,5	2,1	172	176	-	-	258	2	0,37	1,8	2,7	1,8	
	185	264	13,9	7,5	3	174	185	170	14	276	2,5	0,25	2,7	4	2,5	
	193	296	16,7	9	4	177	193	174	8	323	3	0,33	2	3	2	
170	188	243	11,1	6	2,1	181	188	179	9	249	2	0,22	3	4,6	2,8	
	184	235	8,3	4,5	2,1	181	184	-	-	249	2	0,3	2,3	3,4	2,2	
	190	256	13,9	7,5	2,1	182	190	180	8	268	2	0,28	2,4	3,6	2,5	
	185	248	8,3	4,5	2,1	182	185	-	-	268	2	0,37	1,8	2,7	1,8	
	198	282	16,7	9	4	187	198	180	10	293	3	0,25	2,7	4	2,5	
180	199	262	13,9	7,5	2,1	191	199	189	9	269	2	0,22	3	4,6	2,8	
	194	251	8,3	4,5	2,1	191	194	-	-	269	2	0,31	2,2	3,3	2,2	
	202	272	13,9	7,5	3	194	202	191	8	286	2,5	0,28	2,4	3,6	2,5	
	198	266	11,1	6	3	194	198	-	-	286	2,5	0,37	1,8	2,7	1,8	
	208	289	16,7	9	4	197	208	191	18	303	3	0,26	2,6	3,9	2,5	
190	215	288	13,9	7,5	3	204	215	202	9	306	2,5	0,3	2,3	3,4	2,2	
	210	282	11,1	8	3	204	210	-	-	306	2,5	0,40	1,7	2,5	1,6	
	220	306	16,7	9	4	207	220	202	21	323	3	0,26	2,6	3,9	2,5	
200	223	286	13,9	7,5	2,1	211	223	210	10	299	2	0,24	2,8	4,2	2,8	
	227	306	16,7	9	3	214	227	212	9	326	2,5	0,31	2,2	3,3	2,2	
	221	294	11,1	6	3	214	221	-	-	326	2,5	0,40	1,7	2,5	1,6	
	232	324	16,7	9	4	217	232	212	24	343	3	0,26	2,6	3,9	2,5	
	229	320	16,7	9	4	217	229	-	-	343	3	0,35	1,9	2,9	1,8	

¹⁾ Valid for bearings with a cylindrical bore only. Corresponding values for bearings with a tapered bore are listed on page 12, table 2.

Sealed SKF Explorer spherical roller bearings

d 220 – 400 mm

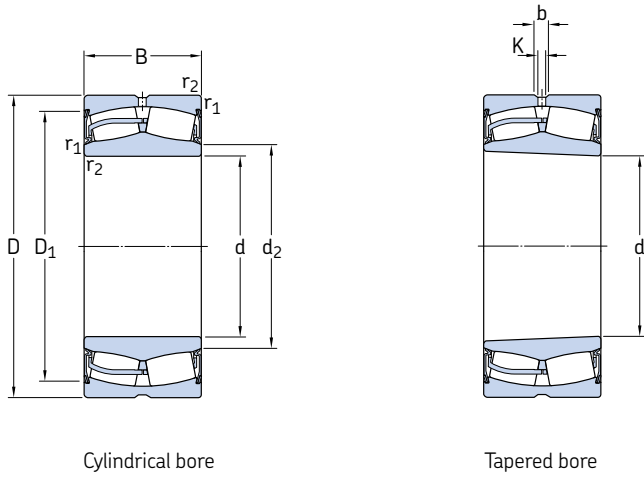

Cylindrical bore

Tapered bore

Principal dimensions			Basic load ratings		Fatigue load limit P_u	Limiting speed	Mass	Designations Bearings with cylindrical bore	Bearings with tapered bore
d	D	B	C	C_0					
mm			kN		kN	r/min	kg	–	
220	340	90	1 220	1 860	163	430	30,5	23044-2CS5/VT143	23044-2CS5K/VT143
	370	120	1 800	2 750	232	360	53,5	23144-2CS5/VT143	23144-2CS5K/VT143
	300	60	546	1 080	93	600	12,5	23944-2CS/VT143	–
	400	108	1 760	2 360	196	380	60,5	22244-2CS5/VT143	22244-2CS5K/VT143
	460	145	2 700	3 450	206	280	115	22344-2CS5/VT143	22344-2CS5K/VT143
240	360	92	1 290	2 080	176	499	33,5	23048-2CS5/VT143	23048-2CS5K/VT143
	400	128	2 080	3 200	255	340	66,5	23148-2CS5/VT143	23148-2CS5K/VT143
260	400	104	1 600	2 550	212	360	47,1	23052-2CS5/VT143	23052-2CS5K/VT143
	440	144	2 550	3 900	290	320	90,5	23152-2CS5/VT143	23152-2CS5K/VT143
280	460	146	2 650	4 250	335	300	97	23156-2CS5/VT143	23156-2CS5K/VT143
300	500	160	3 200	5 100	380	260	125	23160-2CS5/VT143	23160-2CS5K/VT143
320	540	176	3 750	6 100	440	260	165	23164-2CS5/VT143	23164-2CS5K/VT143
340	580	190	4 250	6 800	480	240	210	23168-2CS5/VT143	23168-2CS5K/VT143
360	600	192	4 300	6 950	490	220	213	23172-2CS5/VT143	23172-2CS5K/VT143
400	650	200	4 650	7 650	530	150	255	23180-2CS5/VT143	23180-2CS5K/VT143

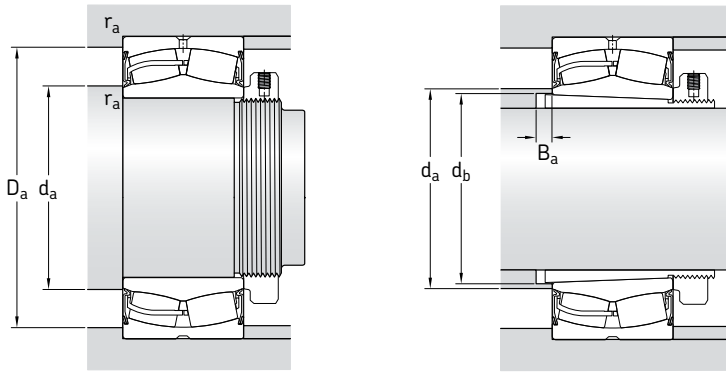

Dimensions

Abutment and fillet dimensions

Calculation factors

d	d ₂ ~	D ₁ ~	b	K	r _{1,2} ¹⁾ min	d _a min	d _a max	d _b min	B _a min	D _a max	r _a max	e	Y ₁	Y ₂	Y ₀
mm						mm						-			
220	245	314	13,9	7,5	3	233	245	231	10	327	2,5	0,24	2,8	4,2	2,8
	249	322	16,7	9	4	237	249	233	10	353	3	0,28	2,4	3,6	2,5
	238	284	8,3	4,5	2,1	231	238	-	-	289	2	0,15	4,5	6,7	4,5
240	257	359	16,7	9	4	237	257	233	21	383	3	0,27	2,5	3,7	2,5
	269	407	22,3	12	5	240	269	236	10	440	4	0,31	2,2	3,3	2,2
240	265	333	13,9	7,5	3	253	365	251	11	347	2,5	0,23	2,9	4,4	2,8
	270	360	16,7	9	4	257	270	254	11	383	3	0,28	2,4	3,6	2,5
260	289	369	16,7	9	4	275	289	272	11	385	3	0,23	2,9	4,4	2,8
	293	398	16,7	9	4	270	293	276	11	423	3	0,3	2,3	3,4	2,2
280	314	417	16,7	9	5	300	314	296	12	440	4	0,3	2,3	3,4	2,2
300	337	450	16,7	9	5	320	337	318	12	480	4	0,3	2,3	3,4	2,2
320	361	483	22,3	12	5	340	361	338	13	520	4	0,3	2,3	3,4	2,2
340	385	517	22,3	12	5	360	385	360	14	560	4	0,31	2,2	3,2	2,2
360	408	542	22,3	12	5	380	408	380	14	580	4	0,28	2,4	3,6	2,5
400	457	588	22,3	12	6	426	457	421	15	624	5	0,28	2,4	3,6	2,5

¹⁾ Valid for bearings with a cylindrical bore only. Corresponding values for bearings with a tapered bore are listed on page 12, table 2.

SKF – the knowledge engineering company

From the company that invented the self-aligning ball bearing more than 100 years ago, SKF has evolved into a knowledge engineering company that is able to draw on five technology platforms to create unique solutions for its customers. These platforms include bearings, bearing units and seals, of course, but extend to other areas including: lubricants and lubrication systems, critical for long bearing life in many applications; mechatronics that combine mechanical and electronics knowledge into systems for more effective linear motion and sensorized solutions; and a full range of services, from design and logistics support to condition monitoring and reliability systems.

Though the scope has broadened, SKF continues to maintain the world's leadership in the design, manufacture and marketing of rolling bearings, as well as complementary products such as radial seals. SKF also holds an increasingly important position in the market for linear motion products, high-precision aerospace bearings, machine tool spindles and plant maintenance services.

The SKF Group is globally certified to ISO 14001, the international standard for environmental management, as well as OHSAS 18001, the health and safety management standard. Individual divisions have been approved for quality certification in accordance with ISO 9001 and other customer specific requirements.

With over 100 manufacturing sites worldwide and sales companies in 70 countries, SKF is a truly international corporation. In addition, our distributors and dealers in some 15 000 locations around the world, an e-business marketplace and a global distribution system put SKF close to customers for the supply of both products and services. In essence, SKF solutions are available wherever and whenever customers need them. Overall, the SKF brand and the corporation are stronger than ever. As the knowledge engineering company, we stand ready to serve you with world-class product competencies, intellectual resources, and the vision to help you succeed.



© Airbus – photo: e*im company, H. Goussé

Evolving by-wire technology

SKF has a unique expertise in the fast-growing by-wire technology, from fly-by-wire, to drive-by-wire, to work-by-wire. SKF pioneered practical fly-by-wire technology and is a close working partner with all aerospace industry leaders. As an example, virtually all aircraft of the Airbus design use SKF by-wire systems for cockpit flight control.

SKF is also a leader in automotive by-wire technology, and has partnered with automotive engineers to develop two concept cars, which employ SKF mechatronics for steering and braking. Further by-wire development has led SKF to produce an all-electric forklift truck, which uses mechatronics rather than hydraulics for all controls.

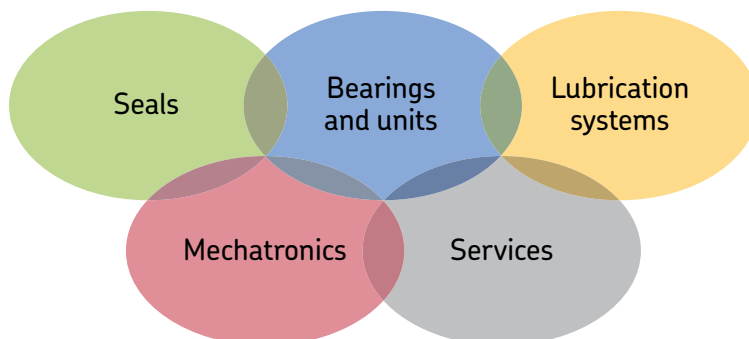



Harnessing wind power

The growing industry of wind-generated electric power provides a source of clean, green electricity. SKF is working closely with global industry leaders to develop efficient and trouble-free turbines, providing a wide range of large, highly specialized bearings and condition monitoring systems to extend equipment life of wind farms located in even the most remote and inhospitable environments.



Working in extreme environments

In frigid winters, especially in northern countries, extreme sub-zero temperatures can cause bearings in railway axleboxes to seize due to lubrication starvation. SKF created a new family of synthetic lubricants formulated to retain their lubrication viscosity even at these extreme temperatures. SKF knowledge enables manufacturers and end user customers to overcome the performance issues resulting from extreme temperatures, whether hot or cold. For example, SKF products are at work in diverse environments such as baking ovens and instant freezing in food processing plants.



Developing a cleaner cleaner

The electric motor and its bearings are the heart of many household appliances. SKF works closely with appliance manufacturers to improve their products' performance, cut costs, reduce weight, and reduce energy consumption. A recent example of this cooperation is a new generation of vacuum cleaners with substantially more suction. SKF knowledge in the area of small bearing technology is also applied to manufacturers of power tools and office equipment.



Maintaining a 350 km/h R&D lab

In addition to SKF's renowned research and development facilities in Europe and the United States, Formula One car racing provides a unique environment for SKF to push the limits of bearing technology. For over 60 years, SKF products, engineering and knowledge have helped make Scuderia Ferrari a formidable force in F1 racing. (The average racing Ferrari utilizes around 150 SKF components.) Lessons learned here are applied to the products we provide to automakers and the aftermarket worldwide.



Delivering Asset Efficiency Optimization

Through SKF Reliability Systems, SKF provides a comprehensive range of asset efficiency products and services, from condition monitoring hardware and software to maintenance strategies, engineering assistance and machine reliability programmes. To optimize efficiency and boost productivity, some industrial facilities opt for an Integrated Maintenance Solution, in which SKF delivers all services under one fixed-fee, performance-based contract.



Planning for sustainable growth

By their very nature, bearings make a positive contribution to the natural environment, enabling machinery to operate more efficiently, consume less power, and require less lubrication. By raising the performance bar for our own products, SKF is enabling a new generation of high-efficiency products and equipment. With an eye to the future and the world we will leave to our children, the SKF Group policy on environment, health and safety, as well as the manufacturing techniques, are planned and implemented to help protect and preserve the earth's limited natural resources. We remain committed to sustainable, environmentally responsible growth.

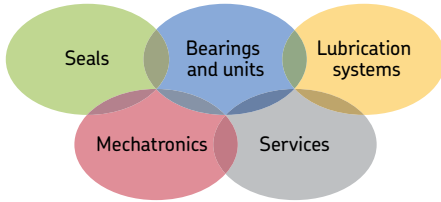

The Power of Knowledge Engineering

Drawing on five areas of competence and application-specific expertise amassed over more than 100 years, SKF brings innovative solutions to OEMs and production facilities in every major industry worldwide. These five competence areas include bearings and units, seals, lubrication systems, mechatronics (combining mechanics and electronics into intelligent systems), and a wide range of services, from 3-D computer modelling to advanced condition monitoring and reliability and asset management systems. A global presence provides SKF customers uniform quality standards and worldwide product availability.

© SKF is a registered trademark of the SKF Group.

™ SKF EXPLORER is a trademark of the SKF Group.

© SKF Group 2010

The contents of this publication are the copyright of the publisher and may not be reproduced (even extracts) unless prior written permission is granted. Every care has been taken to ensure the accuracy of the information contained in this publication but no liability can be accepted for any loss or damage whether direct, indirect or consequential arising out of the use of the information contained herein.

PUB BU/P2 10704 • May 2010

Certain image(s) used under license from Shutterstock.com

