



POWER TRANSMISSION INSTALLATION & MAINTENANCE



INSTALLATION AND MAINTENANCE INSTRUCTIONS

SAFETY: Before the beginning of any maintenance work, make sure that all machine components are in a safety position and that they cannot be changed during maintenance work. The safety instructions of the machine manufacturers must be observed.

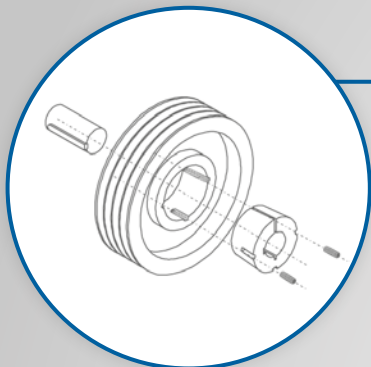

optibelt **KS** V-GROOVED PULLEYS WITH TAPER BUSHES

The V-grooved pulleys are to be checked for damages and correct execution before the initial installation.

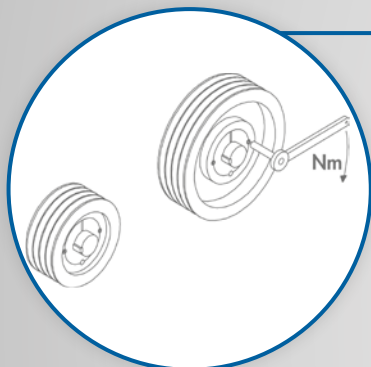

TAPER BUSHES, TIGHTENING TORQUES FOR SCREWS

SIZE	KEY WIDTH	NUMBER OF SCREWS	TORQUE [Nm]
TB 1008, 1108	3	2	5.7
TB 1210, 1215, 1310, 1610, 1615	5	2	20.0
TB 2012	6	2	31.0
TB 2517	6	2	49.0
TB 3020, 3030	8	2	92.0
TB 3525, 3535	10	3	115.0
TB 4040	12	3	172.0
TB 4545	14	3	195.0
TB 5050	14	3	275.0

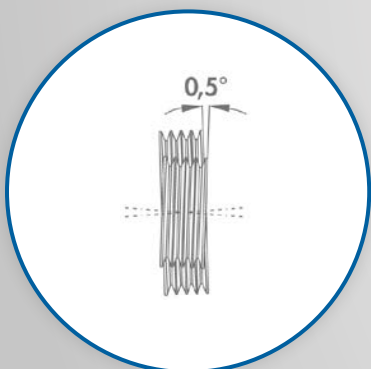

HORIZONTAL ALIGNMENT OF SHAFTS

The motor and machine shaft may be aligned with the **optibelt LASER POINTER II**.

NOTE!

Maximum shaft deviation 0.5°

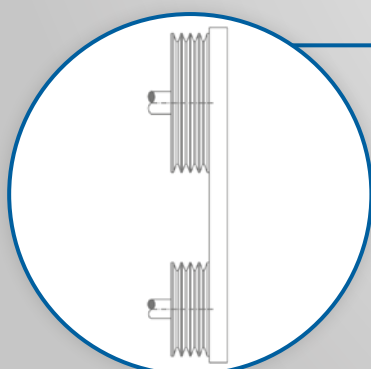

VERTICAL ALIGNMENT OF V-GROOVED PULLEYS

The alignment of the V-grooved pulleys is to be checked before and after the tightening of the taper bushes using a guide rail, straightening cord or with an **optibelt LASER POINTER II**. Error for angle deviation and misalignment, see page 21.

NOTE!

Check whether the pulley face width of the V-grooved pulleys is evenly dimensioned. A possible existing deviation of the pulley face width has to be taken into consideration correspondingly. With a symmetrical pulley face construction, the distance from the guide rail to the smaller face width is half of the deviation.

NOTE: These installation and maintenance instructions apply with appropriate modifications also to Optibelt timing belts and V-ribbed belts. For details see corresponding technical manuals.

INITIAL INSTALLATION

V-belts should be installed without using force. Installation using screwdrivers, crow-bars etc. causes internal and external damage to the belt. Belts installed by force may in some instances only work for a few days. Correct installation of the belt saves time and money. If the adjustment distance is too small, the pulleys should be slipped onto the shafts with the belts attached.

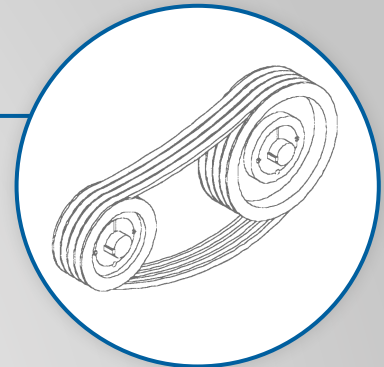

BELT TENSION

Belt tension values should follow Optibelt recommendations. Align the motor parallel up to the stated belt tension. Carry out several belt revolutions and check static strand force again. Experience has shown that belt tension needs to be checked again after 0.5 to 4 hours and then corrected, if necessary. For further information on tensioning gauges and how to use them, see page 6 and 7.

* optibelt OPTIKRIK

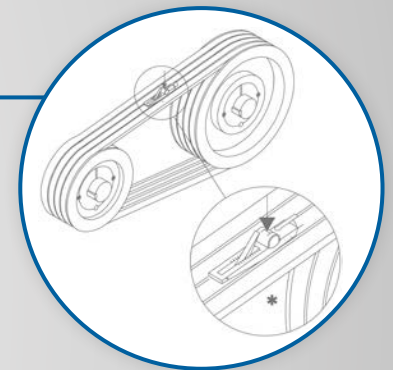

PERMISSIBLE SHAFT MISALIGNMENT

After tightening to the correct initial installation tension, the distances X_1 , X_2 between the two pulleys d_{d1} and d_{d2} and the guide rail at shaft level should be measured. The distances measured should ideally fall below the maximum permissible values for the distance X from the table, depending on the pulley diameters d_d . According to pulley diameter, the interim values for X are to be interpolated. For further specifications on toothed belt drives, see technical manuals toothed belt drives rubber and polyurethane.

PULLEY DIAMETER d_{d1}, d_{d2}	MAXIMUM PERMISSIBLE CENTRE DISTANCE X_1, X_2
112 mm	0.5 mm
224 mm	1.0 mm
450 mm	2.0 mm
630 mm	3.0 mm
900 mm	4.0 mm
1100 mm	5.0 mm
1400 mm	6.0 mm
1600 mm	7.0 mm

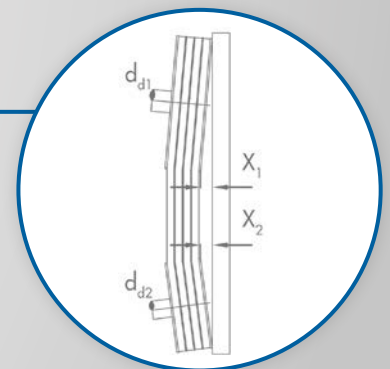

INSPECTIONS

We recommend that the drive should be inspected regularly, e.g. after 3 to 6 months. Pulleys should be checked for wear and tear and overall condition. The Optibelt profile gauges for V-belt and V-ribbed belt drives are used as aids.

** section and pulley groove template

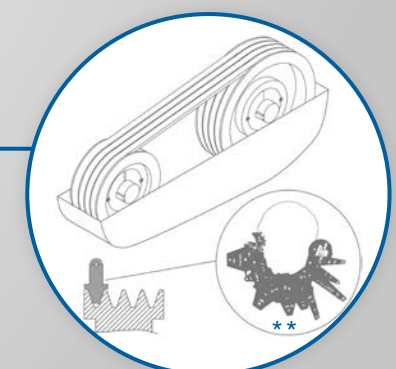

INSTALLATION MAINTENANCE

V-PULLEYS WITH TAPER BUSHES



INSTALLATION

1. All shiny surfaces such as bore and end envelope of cone of the taper bush as well as conical bore of the pulley should be clean and free of grease. Fit the taper bush into the hub and align with all holes. The half-tapped holes should be aligned with the half plain bored holes.
2. Lightly oil the stud screws (TB 1008-3030) and/or fillister socket screws (TB 3525-5050) and screw them in. Do not yet tighten screws.
3. Clean and degrease the shaft. Position the pulley with the taper bush in the correct place on the shaft. See information about V-grooved pulley alignment.
4. If a key is used, place this first into the key way of the shaft. Make sure there is a tolerance between the key and the bore key way.
5. Using a socket wrench according to DIN 911, tighten the stud screws or the fillister socket screws evenly to the torque values given in the table (see page 2).
6. After a short run (0.5 to 1 hour), check the tightening torque values of the screws and tighten if necessary.
7. Fill the empty bush bores with grease to prevent foreign matter from entering.

AND INSTRUCTIONS



WHEN V-PULLEYS WITH TAPER BUSH ARE BEING REPLACED, THE FOLLOWING POINTS SHOULD BE NOTED:

1. Loosen all screws. According to bush size, completely unscrew one or two screws, grease them and screw them into the proof test bores.
2. Tighten the screw or screws evenly until the bush comes out of the hub and the pulley can move freely on the shaft.
3. Remove pulley with bush from the shaft.

INSTALLATION



Dimensions
TB 1008-3030

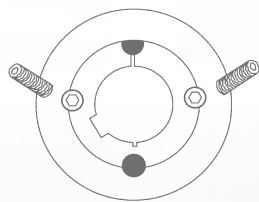

Dimensions
TB 3525-5050

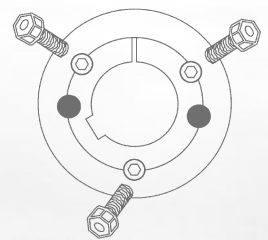

DISASSEMBLY



Dimensions
TB 1008-3030

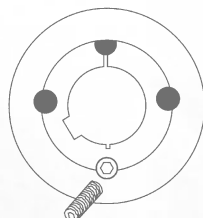

Dimensions
TB 3525-5050

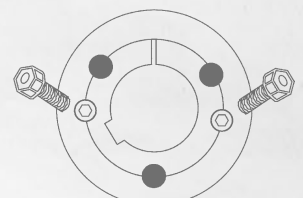

BELT TENSION

OPTIBELT TENSION TESTERS

optibelt OPTIKRIK

The **optibelt OPTIKRIK** is used to simplify the measurement of the belt tension or the static strand force of a two-pulley drive equipped with V-belts, kraftbands and V-ribbed belts.

Default values for the static strand force of different profiles can be found on pages 8 and 9.

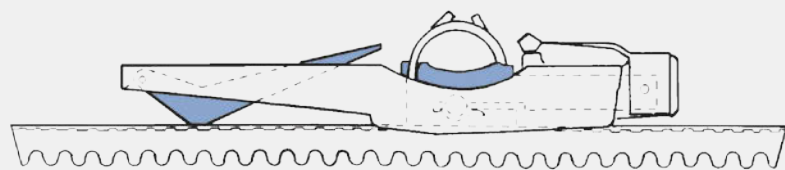
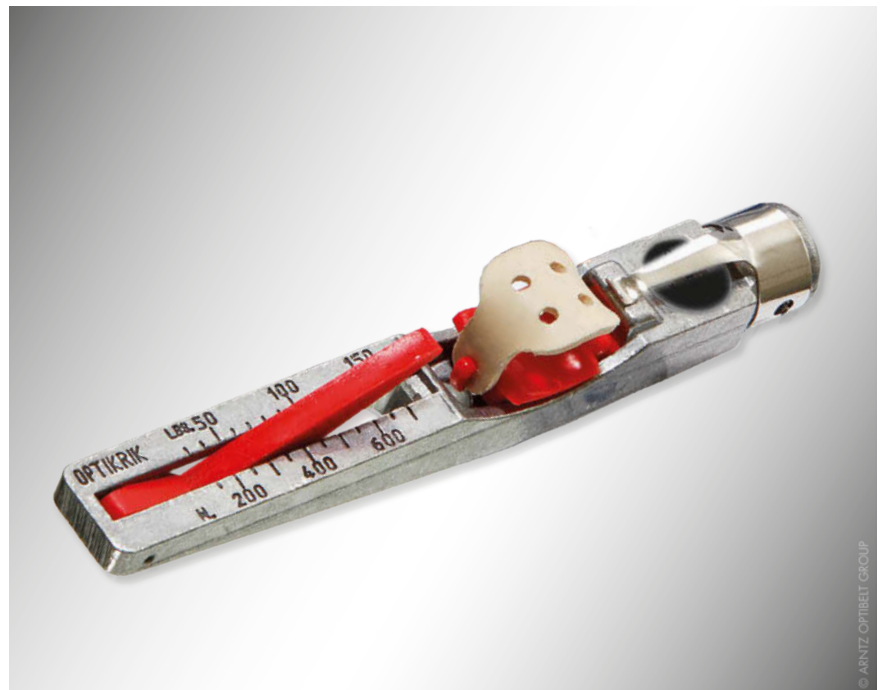

INSTRUCTIONS FOR USE

1. Drive must be unloaded.
2. The gauge is placed in the middle between the two pulleys on the back of the belt, the indicator arm must lie at the very bottom of the scale surface.
3. Lay the gauge loosely on the belt to be measured and press a finger slowly onto the pressure surface.
4. Try not to touch the gauge with more than one finger during the measuring process.
5. Once you hear or feel a definite click, immediately release pressure and the indicator arm will remain in the measured position.
6. Carefully lift the gauge without moving the indicator arm, read off the strand force (see fig.).
7. Reduce or increase the belt tension according to the measurement result until the static strand force is shown. Default values, see pages 8 and 9.

optibelt TT3

This **optibelt TT 3** frequency tension tester is used for tension checking of drive belts by means of frequency measurement. Measurements are in Hertz [Hz]. When belt parameters are entered, tension is indicated in Newton [N].

TECHNICAL DATA

- Measuring range from 10-600 Hz
- Resolution:
 - < 100 Hz: 0.1 Hz
 - > 100 Hz: 1.0 Hz
- Input values:
 - Span length ≤ 10000 mm
 - Belt weight < 10000 g/m
 - Strand force 1-60000 N
- Sensor: acoustic, with electronic suppression of noise interference
- Display: LCD, 2 rows each 16 digits
- Power supply – selectable –
 - Batteries: 2 x 1.5 V
Mignon cells (AA)
 - Rechargeable battery: 2.4 V,
1000 mAh
- Temperature range: +5 °C to 70 °C
- Dimensions: 205 x 95 x 40 mm
(without sensor)
- Weight: 230 g (w/o batteries)



PRODUCT BENEFITS

- Non-contact, repetition sure measurement
- Large measurement range from 10-600 Hz
- High accuracy of measurement
- Quality assessment of the measurement results
- Storage in a data base
- Easy to use
- Universal measuring head for comfortable measuring
- Data communication via PC

**PLEASE ALSO NOTE
OUR PUBLICATIONS
ON optibelt TT DATA
AND optibelt TT RFID**

optibelt TT

The **optibelt TT** frequency tension tester is used to check the tension of drive belts by measuring their frequency of vibration. Due to its compact design, it offers universal application possibilities for drives in engineering, in the automotive industry and for many other technical applications.

Even in difficult-to-access areas, the **optibelt TT** can be used effortlessly, so that V-belts, V-ribbed belts and timing belts can be easily and quickly checked for their tension values. The appliance is ready for data transfer straight away after switching on.

The measuring head must be held over the belt to be measured (two red LED light points help in positioning). Subsequently, the tensioned belt is vibrated (plucking/ striking with the finger is sufficient).

The **optibelt TT** starts the data collection and displays the result in Hertz [Hz]. The texture, colour and type of the belt have no influence on the measurability.

PRODUCT BENEFITS

- Interference-free measurement methods:
 - EM: Electromagnetic waves
 - AC: Acceleration, integrated
- Even for large axle distances thanks to the hitherto unrivalled high frequency range:
 - AC: 1-16 Hz
 - EM: 6-600 Hz
- Simple measuring head handling:
 - Two red LED light points on the belt aid positioning
- For hard-to-reach belt spans:
 - Measuring head on flexible swan neck (EM) or on 250 mm cable (AC)
- Easy to read large screen:
 - 43 mm wide and 58 mm high, illuminated and coloured
- Long running time by powerful, rechargeable battery; environmentally friendly due to interchangeability
- Rechargeable via USB
- Trouble-free in noisy and bright surroundings
- Automatic switch-off function



OPTIBELT V-BELTS

PROFILE	DIAMETER OF THE SMALL PULLEY d_d [mm]	SIMPLIFIED DEFAULT VALUES OF THE STATIC STRAND FORCE [N]					
		RED POWER 3**		SK, VB		SUPER X-POWER M=S XE-POWER PRO (SUPER TX M=S)	
		Initial installation new V-belts	New installation operation after running-in	Initial installation new V-belts	New installation operation after running-in	Initial installation new V-belts	New installation operation after running-in
SPZ; 3V/9N; XPZ; 3VX/9NX	≤ 71	250	200	200	150	250	200
	$> 71 \leq 90$	300	250	250	200	300	250
	$> 90 \leq 125$	400	300	350	250	400	300
	> 125 *						
SPA; XPA	≤ 100	400	300	350	250	400	300
	$> 100 \leq 140$	500	400	400	300	500	400
	$> 140 \leq 200$	600	400	500	400	600	450
	> 200 *						
SPB; 5V/15N; XPB; 5VX/15NX	≤ 160	700	550	650	500	700	550
	$> 160 \leq 224$	850	650	700	550	850	650
	$> 224 \leq 355$	1000	800	900	700	1000	800
	> 355 *						
SPC; XPC	≤ 250	1400	1100	1000	800	1400	1100
	$> 250 \leq 355$	1600	1200	1400	1100	1600	1200
	$> 355 \leq 560$	1900	1500	1800	1400	1900	1500
	> 560 *						
Z/10; ZX/X10	≤ 50			90	70	120	90
	$> 50 \leq 71$			120	90	140	110
	$> 71 \leq 100$			140	110	160	130
	> 100 *						
A/13; AX/X13	≤ 80			150	110	200	150
	$> 80 \leq 100$			200	150	250	200
	$> 100 \leq 132$			300	250	400	300
	> 132 *						
B/17; BX/X17	≤ 125			300	250	450	350
	$> 125 \leq 160$			400	300	500	400
	$> 160 \leq 200$			500	400	600	450
	> 200 *						
C/22; CX/X22	≤ 200			700	500	800	600
	$> 200 \leq 250$			800	600	900	700
	$> 250 \leq 355$			900	700	1000	800
	> 355 *						

* Tension values for these pulleys must be calculated.

** Maintenance-free **optibelt RED POWER 3** belts should be tensioned after approx. 10 min. running-in to the initial installation value. Further testing and re-tensioning after running-in is not necessary.

Tension gauges			Procedure
OPTIKRIK 0	Measuring range:	70– 150 N	
OPTIKRIK I	Measuring range:	150– 600 N	
OPTIKRIK II	Measuring range:	500–1400 N	
OPTIKRIK III	Measuring range:	1300–3100 N	
<p>The tension values (static strand force) are guideline values only, if no concrete default values for the drive are available, e.g. from the machine manufacturer and/or there is insufficient data for a CAP drive calculation. These relate to the maximum transfer capacity per V-belt.</p>			<ol style="list-style-type: none"> Determine the profile, product, condition (new / used), pulley diameter of the small pulley. Read off the specified values of the static strand force from the table above. Determining the existing static strand force and setting the default value such as by using optibelt OPTIKRIK as described on page 6.
<p>Calculation basis</p> <p>Wedge belts: speed $v = 5$ to 42 m/s Classic V-belts: speed $v = 5$ to 30 m/s</p>			
			<p>Example</p> <ol style="list-style-type: none"> Product: SK, profile: SPZ, condition: new, Ø small pulley: 100 mm Stat. strand force – initial installation 350 N Stat. strand force – operation after running-in 250 N

OPTIBELT V-RIBBED BELTS

PROFILE	DIAMETER OF THE SMALL PULLEY d_b [mm]	SIMPLIFIED DEFAULT VALUES OF THE STATIC STRAND FORCE [N]									
		Initial installation	Operation after running-in	Initial installation	Operation after running-in	Initial installation	Operation after running-in	Initial installation	Operation after running-in	Initial installation	Operation after running-in
PH	≤ 25	4 PH		8 PH		12 PH		16 PH		20 PH	
	$> 25 \leq 71$	90	70	150	130	250	200	300	250	400	300
	> 71 *	110	90	200	150	300	250	350	300	450	350
PJ	≤ 40	4 PJ		8 PJ		12 PJ		16 PJ		24 PJ	
	$> 40 \leq 80$	200	150	350	300	500	400	700	550	1000	800
	$> 80 \leq 132$	200	150	400	350	600	500	800	650	1200	1000
	> 132 *	250	200	450	350	700	550	900	700	1300	1000
PK	≤ 63	4 PK		8 PK		10 PK		12 PK		16 PK	
	$> 63 \leq 100$	300	250	600	450	700	600	900	700	1200	900
	$> 100 \leq 140$	400	300	800	600	1000	700	1200	900	1500	1200
	> 140 *	450	350	900	700	1100	800	1300	1000	1600	1300
PL	≤ 90	6 PL		8 PL		10 PL		12 PL		16 PL	
	$> 90 \leq 140$	800	600	1000	800	1300	1000	1500	1200	1900	1500
	$> 140 \leq 200$	100	700	1300	1000	1600	1300	1900	1500	2500	1900
	> 200 *	1100	800	1400	1100	1900	1400	2100	1600	2800	2100

* Tension values for these pulleys must be calculated.

<p>Procedure</p> <ol style="list-style-type: none"> 1. Look for the applied section in the column. 2. For this purpose, take the smallest pulley diameter in the drive system. 3. You can read the corresponding strand force from the table. 4. Check the strand force with the tension gauge as described. 	<p>Example</p> <table border="1"> <tr> <td>1. optibelt RB V-ribbed belt profile</td> <td>4 PJ</td> </tr> <tr> <td>2. Smallest pulley diameter in drive d_b</td> <td>100 mm</td> </tr> <tr> <td>3. Stat. strand force – initial installation</td> <td>250 N</td> </tr> <tr> <td>4. Stat. strand force – operation after running-in</td> <td>200 N</td> </tr> </table>	1. optibelt RB V-ribbed belt profile	4 PJ	2. Smallest pulley diameter in drive d_b	100 mm	3. Stat. strand force – initial installation	250 N	4. Stat. strand force – operation after running-in	200 N
1. optibelt RB V-ribbed belt profile	4 PJ								
2. Smallest pulley diameter in drive d_b	100 mm								
3. Stat. strand force – initial installation	250 N								
4. Stat. strand force – operation after running-in	200 N								

OPTIBELT TIMING BELTS

For tension values of Optibelt timing belts please consult the corresponding technical manuals or contact our engineers from the Applications Engineering Department.

PROBLEMS, CAUSES AND REMEDIES

OPTIBELT V-BELTS



BELT BREAKS AFTER SHORT RUNNING PERIOD (BELT TORN)

CAUSE

1. Violent assembly, resulting in damage to the tension cord
2. Drive stalled
3. Ingress of foreign matter during operation
4. Drive undersized, insufficient number of belts

REMEDY

1. Easy placement possible according to the installation instructions
2. Ascertain cause and put it right
3. Fit an effective guard
4. Check drive design and modify if necessary

EXCEPTIONAL FLANK WEAR

CAUSE

1. Static strand force too low
2. Starting torque too high
3. Worn pulley grooves
4. Wrong belt/groove section
5. Wrong groove angle
6. Pulley misalignment
7. Small pulley diameter below recommended minimum
8. Belt slips or catches on protruding parts

REMEDY

1. Check static strand force / re-tension belt if necessary
2. Check drive design and modify if necessary
3. Replace pulleys
4. Adjust belt and groove sections
5. Remachine or replace pulleys
6. Align pulleys
7. Increase pulley diameter (new drive design); use Optibelt special version or **optibelt SUPER X-POWER M=S** or **optibelt SUPER TX**
8. Eliminate faulty components



BREAKS AND CRACKS IN THE BELT SUB-CONSTRUCTION (BRITTLENESS)

CAUSE

1. Outside idler pulley in use whose position and size is not as recommended
2. Abnormal belt slip
3. Pulley diameter too small
4. Excessive exposure to heat
5. Excessive exposure to cold
6. Chemical influences

REMEDY

1. Observe Optibelt recommendations, e.g. increase diameter; use an inside idler pulley on the drive slack side; use **optibelt RED POWER 3** or Optibelt special version
2. Re-tension belt according to installation instructions; check drive design and modify if necessary
3. Maintain minimum pulley diameter; use Optibelt special version or **optibelt SUPER X-POWER M=S** or **optibelt SUPER TX**
4. Eliminate heat source, shield; improve air ventilation; use Optibelt special version XHR (extra heat resistant) or **optibelt SUPER X-POWER M=S**, **optibelt SUPER TX** or use V-belt with Aramid tension cord
5. Warm-up the belt before taking into operation; request Optibelt special version
6. Shield drive; use Optibelt special version



Please contact our Applications Engineering Department if there are other faults.
Please give us as much technical information as possible to assist us with replying to your query.

PROBLEMS, CAUSES AND REMEDIES

OPTIBELT V-BELTS

SEVERE VIBRATIONS

CAUSE

1. Drive undersized
2. Centre distance significantly longer than recommended
3. High shock loading
4. Belt tension too low
5. Grooved pulleys not balanced

REMEDY

1. Check drive design and modify if necessary
2. Reduce centre distance; use idler pulley in the slack side, preferably acting from the inside outwards; use **optibelt KB** kraftbands
3. Use **optibelt KB** kraftbands; use idler pulley; use Optibelt special version
4. Correct static strand force
5. Balance pulleys

BELTS TWIST

CAUSE

1. Wrong belt/groove profile
2. Pulley misalignment
3. Pulley grooves severely worn
4. Static strand force too low
5. Severe belt vibration
6. Foreign objects in the pulley grooves

REMEDY

1. Adjust belt and groove sections
2. Align pulleys
3. Replace pulleys
4. Re-tension drive
5. Use idler pulley in the slack side, preferably acting from the inside outwards; use **optibelt KB** kraftbands
6. Remove foreign matter and protect drive

BELT SPONGY AND STICKY

CAUSE

1. Contaminated with oil, grease or chemicals

REMEDY

1. Protect the drive from external influences; use raw edge **optibelt SUPER X-POWER**, **optibelt SUPER TX** or **optibelt RED POWER 3**; clean pulley grooves with petrol or alcohol before using new belts!

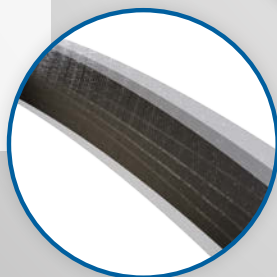
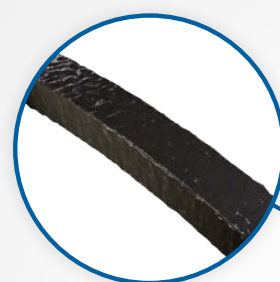

RIBBED BELTS CANNOT BE RE-TENSIONED

CAUSE

1. Adjustment of the centre distance is too small
2. Excessive belt stretching caused by overloaded drive
3. Wrong belt length

REMEDY

1. Change the adjustment according to the Optibelt recommendations
2. Carry out drive calculation and re-design
3. Use shorter belts

EXCESSIVE RUNNING NOISE

CAUSE

1. Pulleys are not aligned
2. Static strand force too low
3. Drive overloaded

REMEDY

1. Realign pulleys
2. Check static strand force and re-tension
3. Check drive design and modify if necessary

UNEVEN BELT STRETCHING

CAUSE

1. Pulley grooves defective
2. Used belts together with new belts combined
3. Different belt makes combined to a single set

REMEDY

1. Replace pulleys
2. Fit completely new set of belts
3. Use belts from just one manufacturer in the set – use **optibelt S=C Plus** (optibelt VB, optibelt SK, optibelt RED POWER 3) or use **M=S** (optibelt SUPER X-POWER optibelt SUPER TX)

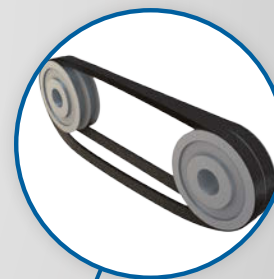

Please contact our Applications Engineering Department if there are other faults. Please give us as much technical information as possible to assist us with replying to your query.

PROBLEMS, CAUSES AND REMEDIES

OPTIBELT V-RIBBED BELTS

EXCESSIVE WEAR OF RIBS

CAUSE

1. Static strand force too low
2. Ingress of foreign matter during operation
3. Pulley misalignment
4. Faulty pulleys
5. Wrong ribbed belt or pulley profile

REMEDY

1. Correct static strand force
2. Fit an effective guard
3. Align pulleys
4. Remachine or replace pulleys
5. Belt and pulley sections must be correctly matched

RIBBED BELT BREAKAGE SHORTLY AFTER FITTING (BELT TORN)

CAUSE

1. V-ribbed belt rubbing or hitting components
2. Drive stalled
3. Drive overloaded
4. Contamination with oil, grease or chemicals

REMEDY

1. Remove any disturbing parts; realign drive
2. Ascertain cause and put it right
3. Check drive design and modify if necessary
4. Protect drive from environmental influences

SEVERE VIBRATIONS

CAUSE

1. Drive undersized
2. Centre distance significantly longer than recommended
3. High shock loading
4. Static strand force too low
5. Unbalanced V-grooved pulley

REMEDY

1. Check drive design and modify if necessary
2. Reduce centre distance; fit idler pulley in the slack side; use larger pulleys
3. Use idler pulley, use larger pulleys
4. Correct static strand force
5. Balance pulleys

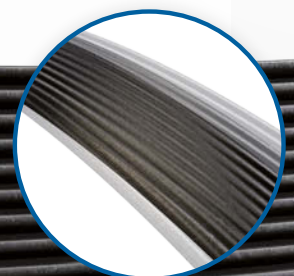

Please contact our Applications Engineering Department if there are other faults.
Please give us as much technical information as possible to assist us with replying to your query.

RIB BREAKAGE AND CRACKS (BRITTLENESS)

CAUSE

1. Outside idler pulley in use whose position and size is not as recommended
2. Pulley diameter too small
3. Excessive exposure to heat
4. Excessive exposure to cold
5. Abnormal belt slip
6. Chemical influences

REMEDY

1. Follow Optibelt recommendations, e.g. increase pulley size; use an inside idler pulley on the drive slack side
2. Ensure minimum pulley diameter
3. Eliminate heat source, shield; improve air ventilation
4. Warm-up the belt before taking into operation
5. Re-tension drive according to installation; check drive ratios and re-dimension if necessary
6. Shield drive

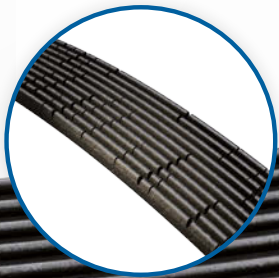

V-RIBBED BELTS CANNOT BE RE-TENSIONED

CAUSE

1. Adjustment of the centre distance is too small
2. Excessive belt stretching caused by overloaded drive
3. Wrong belt length

REMEDY

1. Change adjustment according to Optibelt recommendations
2. Carry out drive calculation and re-design
3. Use shorter belts



EXCESSIVE RUNNING NOISE

CAUSE

1. Pulleys are not aligned
2. Static strand force too low or too high
3. Drive overloaded

REMEDY

1. Realign pulleys
2. Correct static strand force
3. Check drive design and modify if necessary

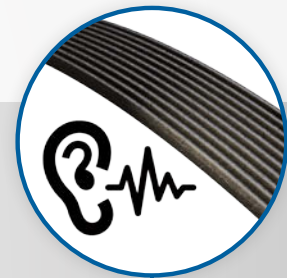

RIBBED BELT SPONGY AND STICKY

CAUSE

1. Contamination with oil, grease or chemicals

REMEDY

1. Protect the drive from external influences; clean pulleys with petrol or alcohol before using new V-ribbed belts!

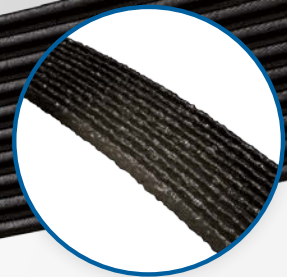

PROBLEMS, CAUSES AND REMEDIES

OPTIBELT TIMING BELTS

BELT TEETH SHEARING OFF (BELT BREAK)

CAUSE

1. Belt bent before or during assembly
2. Overload
3. Number of meshed teeth too low
4. Foreign body in the drive
5. Tension too high

REMEDY

1. Do not bend the belt
2. Use wider belt or larger pulleys
3. Increase the diameter of the small pulley or choose wider belts
4. Remove foreign matter and protect drive
5. Correct tension

HEAVY WEAR ON THE LOADED TOOTH FLANKS

CAUSE

1. Incorrect belt tension
2. Overload, drive undersized
3. Pitch error
4. Faulty timing belt pulleys

REMEDY

1. Correct tension
2. Use wider belts with a higher transmission capacity, or increase size of timing belts and /or pulleys
3. Check profile, and replace if necessary
4. Replace timing belt pulleys

EXTRAORDINARY WEAR ON BELT SIDES

CAUSE

1. Alignment error
2. Faulty flanged pulley
3. Adjustment of the centre distance

REMEDY

1. Realign shafts
2. Replace flanged pulleys
3. Reinforce bearing or housing

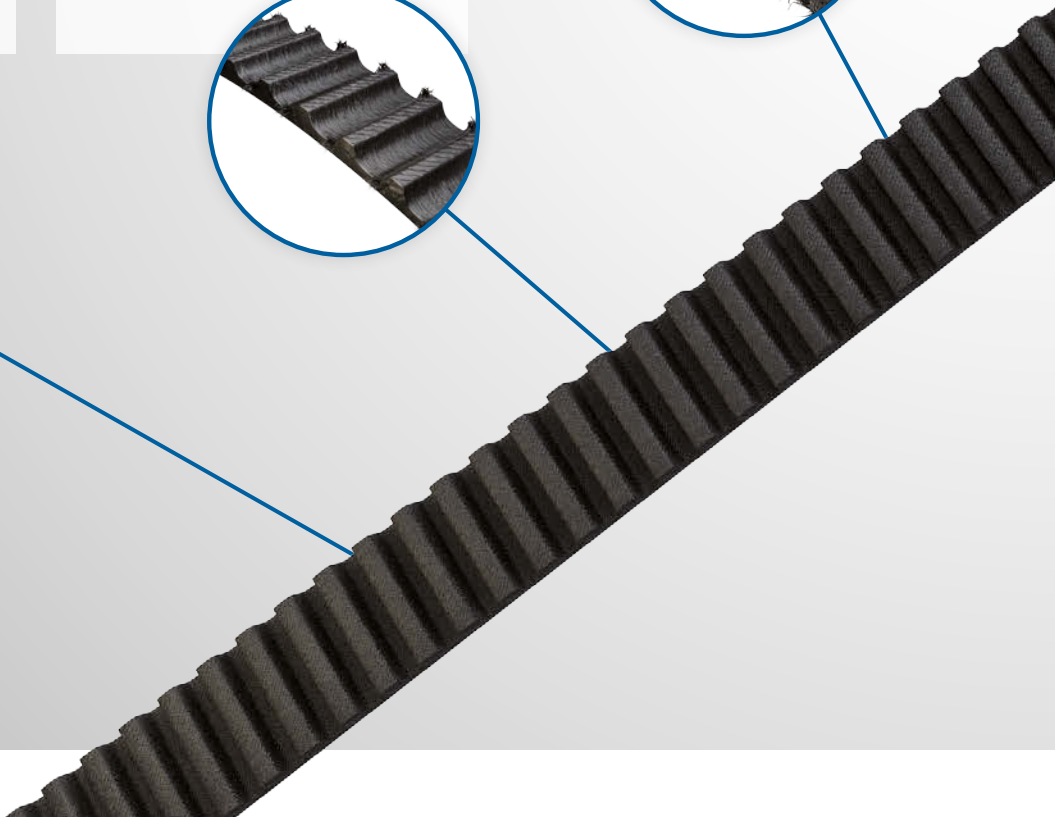

EXCESSIVE LATERAL BELT MOVEMENT

CAUSE

1. Alignment error
2. Timing belt pulleys not in line
3. Impact load with excessive belt tension

REMEDY

1. Realign shafts
2. Realign pulleys
3. Reduce belt tension

TEARS IN THE LONGITUDINAL DIRECTION

CAUSE

1. Faulty flanged pulley
2. Belt runs onto the flanged pulley
3. Ingress of foreign matter during operation
4. Cutting error when splitting the roller

REMEDY

1. Replace flanged pulleys
2. Align the shafts/pulleys; correct the tension
3. Eliminate foreign body; fit protective device
4. Check cutting adjustment and sleeve / belt guide setting

EXCESSIVE WEAR IN THE TOOTH BASE OF THE BELT

CAUSE

1. Excessive belt tension
2. Drive too weakly designed
3. Faulty timing belt pulleys

REMEDY

1. Reduce tension
2. Increase size of timing belts and/or pulleys
3. Replace timing belt pulleys

Please contact our Applications Engineering Department if there are other faults. Please give us as much technical information as possible to assist us with replying to your query.

PROBLEMS, CAUSES AND REMEDIES

OPTIBELT TIMING BELTS

ABNORMAL WEAR OF TIMING BELT PULLEYS

CAUSE

- 1. Unsuitable material
- 2. Faulty toothing
- 3. Inadequate surface hardness

REMEDY

- 1. Use more solid material
- 2. Replace timing belt pulleys
- 3. Use harder material or perform surface hardening

EMBRITTLMENT OF THE BELT BACK

CAUSE

- 1. Ambient temperature above +85 °C
- 2. Incompatible radiation

REMEDY

- 1. Choose extra heat resistant quality
- 2. Shield from the media or use a suitable belt quality

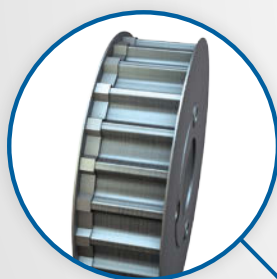
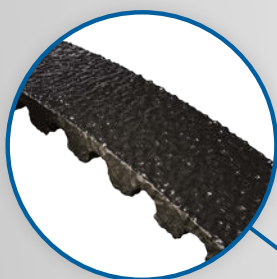

SOFTENING OF THE BELT TOP SURFACE

CAUSE

- 1. Exposure to incompatible media or chemicals

REMEDY

- 1. Shield from the media or use belt with suitable quality

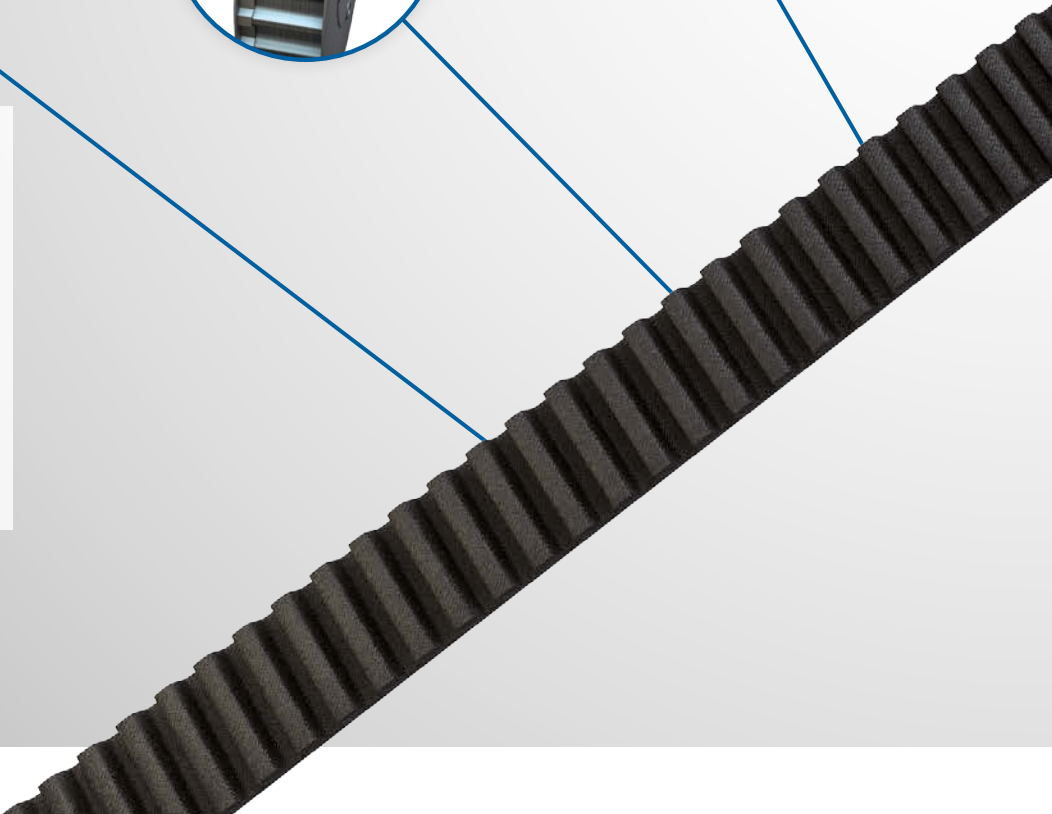

DETACHMENT OF FLANGED PULLEYS

CAUSE

1. Timing belt pulleys not in line
2. Very strong side pressure of the timing belt
3. Faulty installation of the flanged pulleys

REMEDY

1. Realign timing belt pulleys
2. Realign shafts
3. Install flanged pulleys correctly

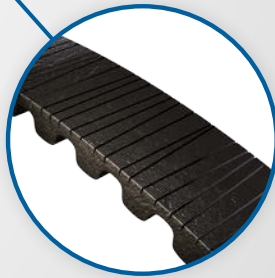
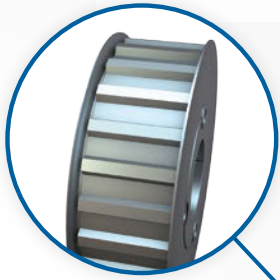

APPARENT BELT STRETCH

CAUSE

1. Yielding mounting

REMEDY

1. Correct the belt tension, reinforce and secure mounting

CRACKS IN THE BACK OF THE BELT

CAUSE

1. Ambient temperature below $-30\text{ }^{\circ}\text{C}$

REMEDY

1. Use extra cold resistant belt quality

EXCESSIVE RUNNING NOISE

CAUSE

1. Faulty shaft alignment
2. Belt tension too high
3. Overloading of timing belt
4. Excessive belt width at high speed

REMEDY

1. Realign shafts
2. Reduce tension
3. Use a belt with higher performance
4. Reduce width of belt by selecting a timing belt with higher performance

Please contact our Applications Engineering Department if there are other faults. Please give us as much technical information as possible to assist us with replying to your query.



SOURCES OF ERRORS

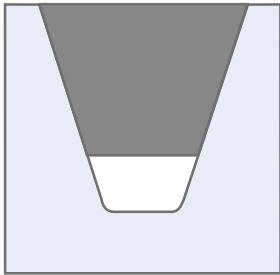

Correct belt arrangement in the V-grooved pulley

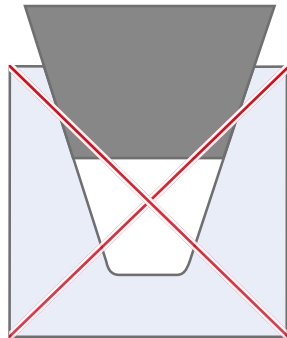

Belt too large / pulley groove too small

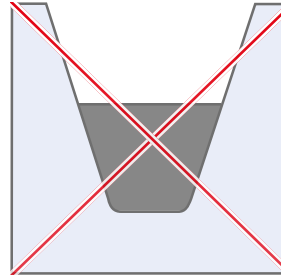

Belt profile too small / pulley profile too large



Worn out V-grooved pulley

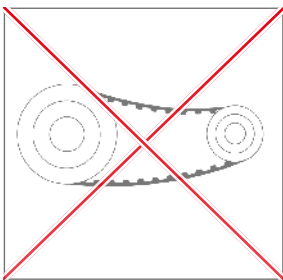

Belt tension too low

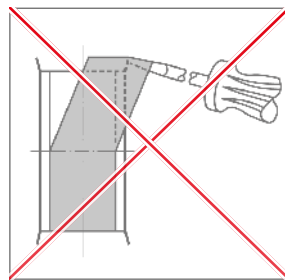

Forcible fitting

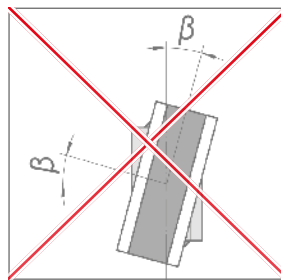

Vertical angular misalignment of shafts



Bent belt

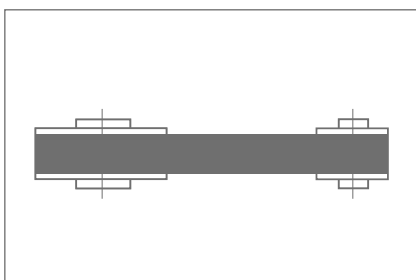

Alignment pulley on the parallel alignment shaft

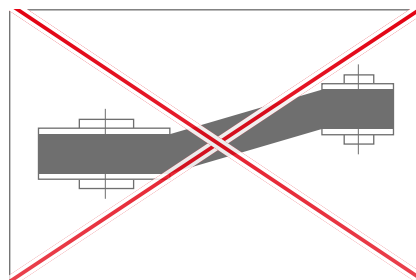

Axial offset of pulleys

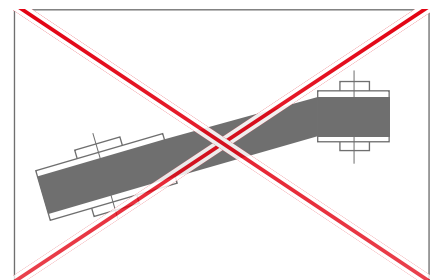

Horizontal angular misalignment of shafts

Optibelt products can only be found at specialist dealers. Optibelt recommends that its products be used exclusively according to the instructions in the Optibelt documentation. Optibelt does not accept any liability for the use of its products in applications for which they were not designed and/or manufactured for. For all other matters, Optibelt refers you to its general terms and conditions.

INSTALLATION, MAINTENANCE AND STO

Geometrically correct designing and power rating of drives with Optibelt V-belts ensures long belt service life and a high degree of operating safety.

Practice has shown that premature failure can very often be traced to faulty installation or maintenance.

To prevent this, we recommend that you observe the following installation and maintenance instructions:

SAFETY

Before the beginning of any maintenance work, make sure that all machine components are in a safety position and that they cannot be changed during maintenance work.

The safety instructions of the machine manufacturers must be observed.

PULLEYS

The grooves must be manufactured according to standard and also be clean.

ALIGNMENT

Shafts and pulleys should be correctly aligned prior to belt installation.

We recommend a maximum tolerance of 0.5° in both planes.

MULTI-GROOVED DRIVES

V-belts for multi-grooved drives must usually be measured to form sets. Please note the set tolerance according to the valid standard. **optibelt S=C Plus** and **M=S** V-belts can, however, be assembled into sets without being measured.

INSTALLATION OF THE V-BELTS

The centre distance should be reduced prior to the installation of the belts so that they may be fitted in the grooves without undue force. Forcing ribbed belts over the pulley flanges with a tyre lever, screwdriver or the like, must be avoided as the damage this causes to the cover fabric and low stretch tension cord is often not visible.

BELT TENSION

Once the calculated axial force has been applied, the tension of the belts should be checked. To do this use our Optibelt tension gauge.

During the first operating hours, the drive must be observed and re-tensioned after a running time under full load of approx. 0.5 to 4 hours. This restores tension to the original level.

TENSION/GUIDE IDLERS

Where possible, the use of tension and guide idlers should be avoided. If this is not possible, the recommendations of our manual must be observed.

MAINTENANCE

It is recommended that V-belt drives should be regularly inspected. This should include checking and, if necessary, correcting the tension. If, with a multi-groove drive one or more V-belts fail, a new V-belt set should be installed. V-belts of different brands may not be merged into a single belt set. Before installing new V-belts, check the condition of V-belt pulleys.

Optibelt V-belts do not require any special care. The use of belt wax and belt spray is to be avoided.

STORAGE – GENERAL

Correctly stored V-belts remain unchanged for several years (see also DIN 7716). Under unfavourable storage conditions and improper handling, however, most rubber products change their physical properties. These changes may be caused e.g. through the effect of oxygen, ozone, extreme temperatures, light, moisture or solvents.

RAGE

STORAGE AREA

The storage area should be dry and free of dust. V-belts must not be stored together with chemicals, solvents, fuels, lubricants, acids, etc.

TEMPERATURE

The storage temperature should be between +15 °C and +25 °C. Lower temperatures have generally no damaging effect on V-belts. Since they may become very rigid through cold temperatures, they should be brought to a temperature of approx. 20 °C prior to being used. This prevents breakages and cracks.

Radiators and their pipes must be shielded. The distance between radiator and storage item must be at least 1 m.

LIGHT

V-belts should be protected from light, especially from direct sunlight and strong artificial light with high ultraviolet (ozone formation), such as openly installed fluorescent tubes.

OZONE

In order to counteract the damaging effect of ozone, the storage rooms must not contain any ozone-producing devices, such as fluorescent light sources, mercury vapour lamps or high-voltage electrical appliances. Combustion gases and vapours which might lead to ozone formation due to photochemical processes, should be avoided or removed.

MOISTURE

Moist storage rooms are not suitable. It must be ensured that no condensation occurs. The most favourable relative moisture is below 65%.

STORAGE

It must be ensured that V-belts are stored in a stress-free way, i.e. without tension, pressure or other deformation, since this tension would favour a permanent deformation or the occurrence of cracks.

If V-belts are stored on top of each other in lying condition, it is suitable to not exceed a height of 300 mm to prevent permanent deformations. If they are kept hanging for space reasons, the diameter of the mandrel should be at least 10 times the height of the belt.

With the optibelt S=C Plus (optibelt VB, optibelt SK, optibelt RED POWER 3) or M=S (optibelt SUPER X-POWER, optibelt SUPER TX) V-belts there is no storage in sets, as they can be formed into sets without being measured.

CLEANING

The cleaning of dirty V-belts can be carried out using a brake cleaner. Petrol, benzene, turpentine, or similar should not be used.

Furthermore, sharp-edged objects, wire brushes, emery paper, etc. must never be used as this will lead to mechanical damage of the V-belts.

Optibelt GmbH

Corveyer Allee 15
37671 Höxter
GERMANY

T +49 (0) 5271-621
F +49 (0) 5271-976200
E info@optibelt.com



www.optibelt.com