

A Smalley Laminar Seal Ring set is a metallic labyrinth seal consisting of multiple rings in a groove. The arrangement and the specific orientation of the rings are dictated by the application and the severity of the environment. There are 16 series of standard imperial and Metric Laminar Seal Ring configurations from which to select. 8 of these series are sets consisting of single-turn rings. The other 8 series are sets consisting of double-turn rings. Within each series are operational ring-set configurations in both imperial and metric sizes. The selection of the appropriate set should be determined by the application. For some applications a complete labyrinth configuration (i.e.; a complete labyrinth configuration is one which has rings staggered within the set) is necessary due to a severe environment where contamination is highly probable. In other applications design engineers can keep the groove dimensions minimal by specifying laminar sets with rings clinging either to the bore or to the shaft.

## Laminar Seal Rings Available From Stock

Standard parts from 3/8" to 50" and 15 mm to 1,300 mm.  
 Special seals manufactured with No-Tooling-Charges.  
 Smalley's Laminar Seal Rings are interchangeable with FEY Rings.

INTERCHANGE LISTING		
SMALLEY	FEY	
QH	AS	FK3
QHK	ASK	
QS	IS	
QSK	ISK	
QHD	ASD	FK6
QHKD	ASKD	
QSD	ISD	
QSKD	ISKD	
CONSULT SMALLEY ENGINEERING		FK5



## Advantages of Laminar Seal Rings

- No friction with other rotating components, ideal for high speed applications.
- Prevent dirt and splash water from contaminating components.
- When used in conjunction with other seals, Laminar Seals provide a primary seal against severe contamination, before the contaminants come in contact with the secondary seal.
- Sets of multiple rings provide an efficient labyrinth seal.
- Rings may be produced from a wide variety of alloys to withstand more severe conditions including higher temperatures and corrosive environments.
- As a metallic mechanical seal they can outperform rubber seals in durability and life expectancy.
- The change from rubber to metal reduces the need for frequent seal replacement.

## Selection Guide Standard Laminar Ring Sets Available

### Single-Turn Laminar Seal Rings

Used in a variety of applications, this series of Seal Rings should be utilized for light to medium duty applications, dependent on the ring configuration specified. The sets are comprised of single-turn rings in either 3 rings per set or 5 rings per set.

**APPLICATIONS:** 3 ring sets protect components from low dirt and low splash water contamination. 5 ring sets provide a better labyrinth seal to protect components from medium dirt and medium splash water contamination.

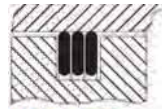

**YH Series  
QH Series**  
Internal - Light Duty  
1 set = 3 individual rings  
(rings rotate with bore only)



**YHK Series  
QHK Series**  
Internal - Medium Duty  
1 set = 5 individual rings  
(3 rings rotate with bore &  
2 rings rotate with shaft)



**YS Series  
QS Series**  
External - Light Duty  
1 set = 3 individual rings  
(rings rotate with shaft only)



**YSK Series  
QSK Series**  
External - Medium Duty  
1 set = 5 individual rings  
(3 rings rotate with shaft &  
2 rings rotate with bore)

### Double-Turn Laminar Seal Rings

The sets are comprised of double-turn rings in either 2 rings per set or 3 rings per set. The double-turn rings fit tighter in the bore or on the shaft, provide complete 360° surface contact and resist higher axial/radial forces than single-turn ring sets, for medium to heavy duty applications.

**APPLICATIONS:** 2 ring sets protect components from medium dirt and medium splash water contamination. 3 ring sets provide a better labyrinth seal to protect components from heavy dirt and heavy splash water contamination.



**YHD Series  
QHD Series**  
Internal - Medium/Heavy Duty  
1 set = 2 individual rings  
(rings rotate with bore only)



**YHKD Series  
QHKD Series**  
Internal - Heavy Duty  
1 set = 3 individual rings  
(2 rings rotate with bore &  
1 ring rotates with shaft)



**YSD Series  
QSD Series**  
External - Medium/Heavy Duty  
1 set = 2 individual rings  
(rings rotate with shaft only)



**YSKD Series  
QSKD Series**  
External - Heavy Duty  
1 set = 3 individual rings  
(2 rings rotate with shaft &  
1 ring rotates with bore)

**A. Coupling**

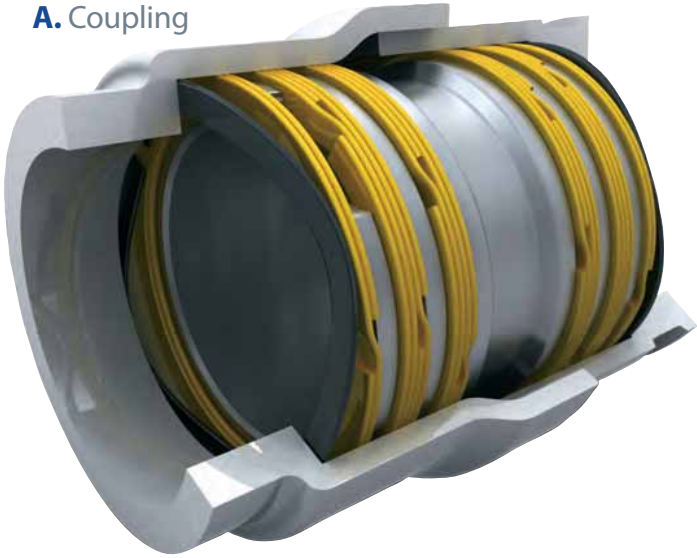

**B. Bearing Protection**

**C. Pulley Idler**



**D. High Speed Spindle**

**A. Coupling**

The seal arrangement in this assembly has been custom designed for optimum protection against contamination. Gases build up pressure in a center cavity, protected on both ends from contaminants entering.

**B. Bearing Protection**

The 3 ring set protects the ball bearing from contaminants like dirt and water. The seal retains grease/lubricant and prevents contaminants from penetrating into the critical components of the assembly.

**C. Pulley Idler**

The ring set designed in this application extends the life of the ball bearing by keeping contaminants from penetrating the precision bearing surfaces even though the bearing itself is sealed. When the shaft rotates only the groove ring rotates while the housing rings remain stationary.

**D. High Speed Spindle**

The QS series has been designed into the spindle assembly to protect the tandem bearings against corrosive elements. Though it is not the primary seal in the assembly, it is designed as the final seal protecting the bearings. All rings in the set will cling to the shaft due to the high rotational speed of the main spindle

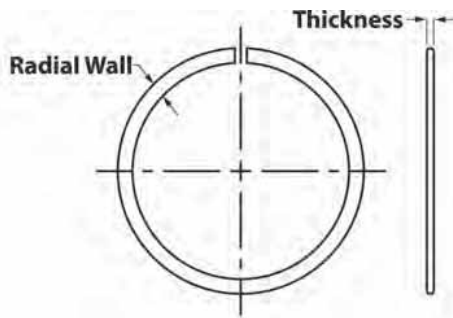

Single-Turn Laminar Sealing Rings YH or YS are used for a wide variety of applications. They are commonly used to protect bearing systems by retaining grease/lubricant and preventing water or other contaminating liquids from penetrating into the critical areas of an assembly. The alternating (staggered) series YHK and YSK offer (due to an increased labyrinth seal) further improved sealing efficiency. They are often specified where the lubricating grease may liquefy due to higher operating temperatures or where protection against larger amounts of contaminating liquids (such as cooling water) is required.

The standard Single-Turn Laminar Rings listed in the table below are readily available (from stock). Specials can be manufactured with No-Tooling-Charges™.

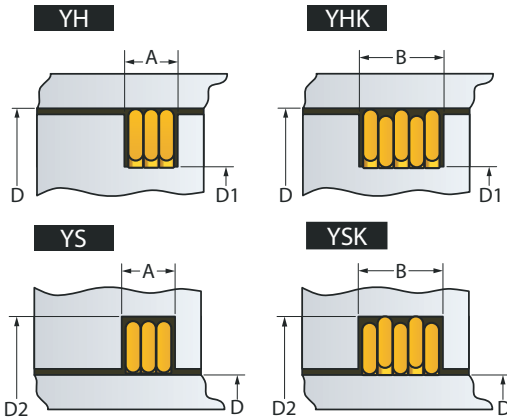

**Product Dimensions** All dimensions in inches unless otherwise specified.

Bore Shaft <sup>1</sup> D	Groove <sup>2</sup> Width		Ring Dimensions		Groove Diameter D2	Groove Diameter D1
	A	B	RW	T		
0.625 - 1.249	0.072	0.119	0.055	0.021	(D) +0.134	(D) -0.134
1.250 - 1.499	0.072	0.119	0.065	0.021	+0.154	-0.154
1.500 - 1.749	0.084	0.139	0.078	0.025	+0.180	-0.180
1.750 - 2.249	0.102	0.170	0.095	0.031	+0.214	-0.214
2.250 - 2.749	0.102	0.170	0.113	0.031	+0.250	-0.250
2.750 - 2.999	0.102	0.170	0.123	0.031	+0.270	-0.270
3.000 - 3.249	0.102	0.170	0.128	0.031	+0.280	-0.280
3.250 - 3.499	0.102	0.170	0.138	0.031	+0.300	-0.300
3.500 - 3.999	0.102	0.170	0.158	0.031	+0.340	-0.340
4.000 - 4.499	0.102	0.170	0.168	0.031	+0.360	-0.360
4.500 - 4.999	0.131	0.215	0.188	0.039	+0.408	-0.408
5.000 - 5.499	0.131	0.215	0.200	0.039	+0.432	-0.432
5.500 - 6.249	0.158	0.254	0.225	0.046	+0.490	-0.490
6.250 - 7.749	0.187	0.301	0.250	0.055	+0.540	-0.540
7.750 - 9.999	0.187	0.301	0.312	0.055	+0.702	-0.702
10.000 - 12.499	0.217	0.346	0.350	0.063	+0.778	-0.778
12.500 - 14.999	0.217	0.346	0.375	0.063	+0.828	-0.828
15.000 - 19.999	0.307	0.496	0.437	0.093	+0.952	-0.952
20.000 - 24.999	0.310	0.504	0.500	0.093	+1.158	-1.158
25.000 - 29.999	0.310	0.504	0.567	0.093	+1.292	-1.292
30.000 - 50.000	0.310	0.504	0.750	0.093	+1.658	-1.658

<sup>1</sup> Standard raw materials are carbon steel and 302 stainless steel.

<sup>2</sup> If axial movement occurs during operation, an increase to Groove Width may be necessary to avoid friction between Rings and Groove.

Tolerances (in)				
D	0.625 - 4.499	4.500 - 9.999	10.000 - 14.999	15.000 - 50.000
A-B	+0.004 -0.000	+0.008 -0.000	+0.010 -0.000	+0.010 -0.000
RW	+0.004 -0.004	+0.006 -0.006	+0.007 -0.007	+0.015 -0.010
T	+0.002 -0.002	+0.003 -0.003	+0.004 -0.004	+0.005 -0.005
D2	+0.008 -0.000	+0.012 -0.000	+0.012 -0.000	+0.016 -0.000
D1	+0.000 -0.008	+0.000 -0.012	+0.000 -0.012	+0.000 -0.016

Double-Turn Laminar Sealing Rings offer a higher clamping force when installed in the bore or on the shaft. They are suited for higher operating speeds, have 360° contact (no axial gap) and should be used where application conditions are more severe. One typical application is where high amounts of dirt and dust are present and the ring sets provide the necessary seal against contamination from outside elements.

Double-Turn Laminar Ring Sets are also used to protect contacting radial seals, rubber seals, O-rings and other oil seals. For protection in the most severe environment the alternating (staggered) sets YHKD and YSKD are the preferred choice by engineers. They provide sealing with 360° contact in both the bore and on the shaft.

The standard Double-Turn Laminar Rings listed in the table below are readily available (from stock). Specials can be manufactured with No-Tooling-Charges™.

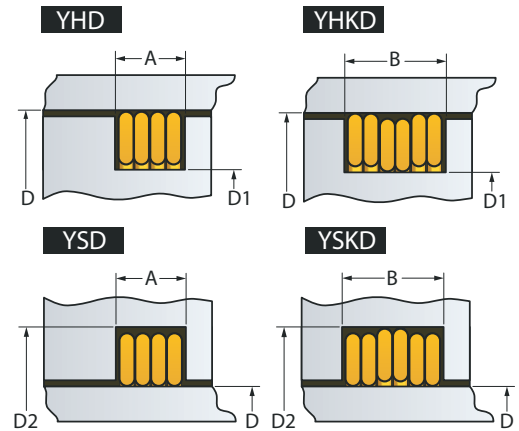
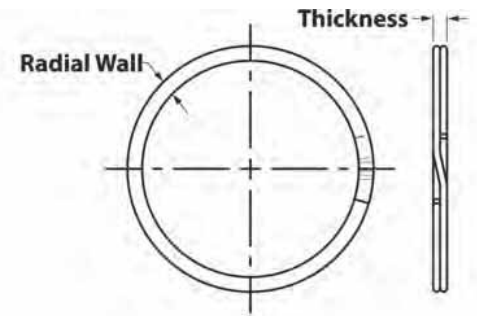

**Product Dimensions** All dimensions in inches unless otherwise specified.

Bore Shaft <sup>1</sup> D	Groove <sup>2</sup> Width		Ring Dimensions		Groove Diameter D2	Groove Diameter D1
	A	B	RW	T		
0.625 - 1.249	0.098	0.145	0.055	0.043	(D) +0.134	(D) -0.134
1.250 - 1.499	0.098	0.145	0.065	0.043	+0.154	-0.154
1.500 - 1.749	0.112	0.166	0.078	0.050	+0.180	-0.180
1.750 - 2.249	0.136	0.204	0.095	0.062	+0.214	-0.214
2.250 - 2.749	0.136	0.204	0.113	0.062	+0.250	-0.250
2.750 - 2.999	0.136	0.204	0.123	0.062	+0.270	-0.270
3.000 - 3.249	0.136	0.204	0.128	0.062	+0.280	-0.280
3.250 - 3.499	0.136	0.204	0.138	0.062	+0.300	-0.300
3.500 - 3.999	0.136	0.204	0.158	0.062	+0.340	-0.340
4.000 - 4.499	0.136	0.206	0.168	0.062	+0.360	-0.360
4.500 - 4.999	0.172	0.254	0.188	0.078	+0.408	-0.408
5.000 - 5.499	0.172	0.254	0.200	0.078	+0.432	-0.432
5.500 - 6.249	0.202	0.299	0.225	0.093	+0.490	-0.490
6.250 - 7.749	0.238	0.353	0.250	0.111	+0.540	-0.540
7.750 - 9.999	0.242	0.357	0.312	0.111	+0.702	-0.702
10.000 - 12.499	0.274	0.405	0.350	0.127	+0.778	-0.778
12.500 - 14.999	0.278	0.412	0.375	0.127	+0.828	-0.828
15.000 - 19.999	0.398	0.592	0.437	0.187	+0.952	-0.952
20.000 - 24.999	0.398	0.596	0.500	0.187	+1.158	-1.158
25.000 - 29.999	0.405	0.608	0.567	0.187	+1.292	-1.292
30.000 - 50.000	0.413	0.620	0.750	0.187	+1.658	-1.658

Tolerances (in)				
D	0.625 - 4.499	4.500 - 9.999	10.000 - 14.999	15.000 - 50.000
	+0.004	+0.008	+0.010	+0.010
A-B	-0.000	-0.000	-0.000	-0.000
	+0.004	+0.006	+0.007	+0.015
RW	-0.004	-0.006	-0.007	-0.010
	+0.002	+0.003	+0.004	+0.005
T	-0.002	-0.003	-0.004	-0.005
	+0.008	+0.012	+0.012	+0.016
D2	-0.000	-0.000	-0.000	-0.000
	+0.000	+0.000	+0.000	+0.000
D1	-0.008	-0.012	-0.012	-0.016

<sup>1</sup> Standard raw materials are carbon steel and 302 stainless steel.

<sup>2</sup> If axial movement occurs during operation, an increase to Groove Width may be necessary to avoid friction between Rings and Groove.

Single-Turn Laminar Sealing Rings QH or QS are used for a wide variety of applications. They are commonly used to protect bearing systems by retaining grease/lubricant and preventing water or other contaminating liquids from penetrating into the critical areas of an assembly. The alternating (staggered) series QHK and QSK offer (due to an increased labyrinth seal) further improved sealing efficiency. They are often specified where the lubricating grease may liquefy due to higher operating temperatures or where protection against larger amounts of contaminating liquids (such as cooling water) is required.

The Metric Single-Turn Laminar Rings listed in the table below are readily available (from stock). Specials can be manufactured with No-Tooling-Charges™.

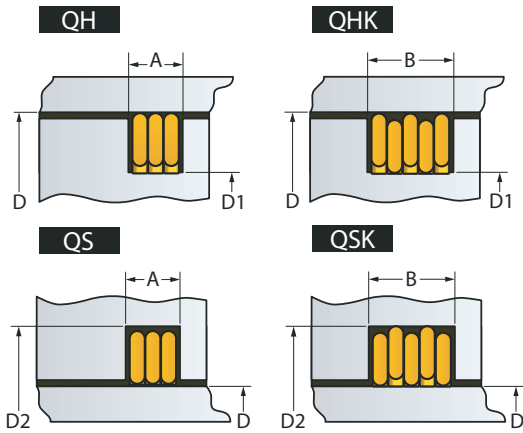
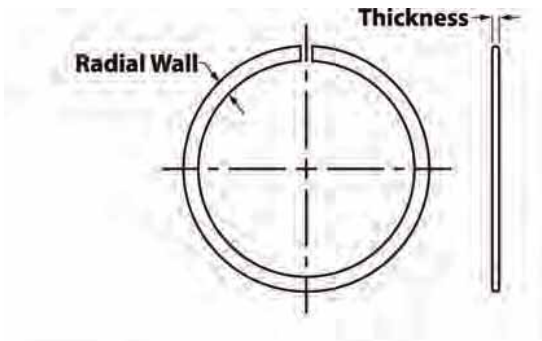

**Product Dimensions** All dimensions in millimeters unless otherwise specified.

Bore Shaft D	Groove <sup>2</sup> Width		Ring Dimensions		Groove Diameter D2	Groove Diameter D1
	A	B	RW	T		
15 - 24.9	2.2	3.6	1.0	0.65	(D) + 2.6	(D) - 2.6
25 - 29.9	2.2	3.6	1.2	0.65	+ 3.0	- 3.0
30 - 35.9	2.2	3.6	1.5	0.65	+ 3.6	- 3.6
36 - 42.9	2.2	3.6	1.8	0.65	+ 4.2	- 4.2
43 - 48.9	2.4	4.0	2.2	0.72	+ 5.0	- 5.0
49 - 51.9	2.4	4.0	2.4	0.72	+ 5.4	- 5.4
52 - 59.9	2.4	4.0	2.6	0.72	+ 5.8	- 5.8
60 - 69.9	2.7	4.5	2.8	0.82	+ 6.2	- 6.2
70 - 74.9	2.7	4.5	3.1	0.82	+ 6.8	- 6.8
75 - 79.9	2.7	4.5	3.3	0.82	+ 7.2	- 7.2
80 - 89.9	2.7	4.5	3.5	0.82	+ 7.6	- 7.6
90 - 99.9	2.7	4.5	3.8	0.82	+ 8.2	- 8.2
100 - 104.9	2.7	4.5	4.1	0.82	+ 8.8	- 8.8
105 - 109.9	3.3	5.5	4.3	0.98	+ 9.2	- 9.2
110 - 119.9	3.3	5.5	4.6	0.98	+ 9.8	- 9.8
120 - 129.9	3.3	5.5	5.0	0.98	+10.8	-10.8
130 - 149.9	3.3	5.5	5.5	0.98	+11.8	-11.8
150 - 170.9	3.4	5.6	6.0	1.00	+13.0	-13.0
150 <sup>1</sup> - 170.9	5.1	8.2	6.0	1.50	+13.0	-13.0
171 - 199.9	3.4	5.6	7.0	1.00	+15.0	-15.0
171 <sup>1</sup> - 199.9	5.1	8.2	7.0	1.50	+15.0	-15.0
200 - 259.9	4.1	6.6	8.0	1.20	+18.0	-18.0
200 <sup>1</sup> - 259.9	5.1	8.2	8.0	1.50	+18.0	-18.0
260 - 319.9	5.1	8.2	9.0	1.50	+20.0	-20.0
320 - 399.9	5.2	8.3	10.0	1.50	+22.0	-22.0
400 - 439.9	5.2	8.3	11.0	1.50	+24.0	-24.0
440 - 600.9	5.2	8.3	12.0	1.50	+26.0	-26.0
440 <sup>1</sup> - 600.0	8.3	13.5	12.0	2.50	+26.0	-26.0
601 - 699.9	8.3	13.5	14.0	2.50	+32.0	-32.0
700 - 799.9	8.3	13.5	16.0	2.50	+36.0	-36.0
800 - 899.9	8.3	13.5	18.0	2.50	+40.0	-40.0
900 - 999.9	8.3	13.5	20.0	2.50	+44.0	-44.0
1000 - 1300.0	8.4	13.6	22.0	2.50	+48.0	-48.0

Tolerances (mm)				
D	15 - 104.9	105 - 149.9	150 - 439.9	440 - 1300
A-B	+0.10 -0.00	+0.15 -0.00	+0.20 -0.00	+0.25 -0.00
RW	+0.10 -0.10	+0.10 -0.20	+0.15 -0.30	+0.20 -0.40
T	+0.04 -0.02	+0.05 -0.03	+0.06 -0.04	+0.07 -0.05
D2	+0.20 -0.00	+0.25 -0.00	+0.30 -0.00	+0.40 -0.00
D1	+0.00 -0.20	+0.00 -0.25	+0.00 -0.30	+0.00 -0.40

<sup>1</sup> Increased cross-section.

<sup>2</sup> If axial movement occurs during operation, an increase to Groove Width may be necessary to avoid friction between Rings and Groove.

Double-Turn Laminar Sealing Rings offer a higher clamping force when installed in the bore or on the shaft. They are suited for higher operating speeds, have 360° contact (no axial gap) and should be used where application conditions are more severe. One typical application is where high amounts of dirt and dust are present and the ring sets provide the necessary seal against contamination from outside elements.

Double-Turn Laminar Ring Sets are also used to protect contacting radial seals, rubber seals, O-rings and other oil seals. For protection in the most severe environment the alternating (staggered) sets QHKD and QSKD are the preferred choice by engineers. They provide sealing with 360° contact in both the bore and on the shaft.

The Metric Double-Turn Laminar Rings listed in the table below are readily available (from stock). Specials can be manufactured with No-Tooling-Charges™.

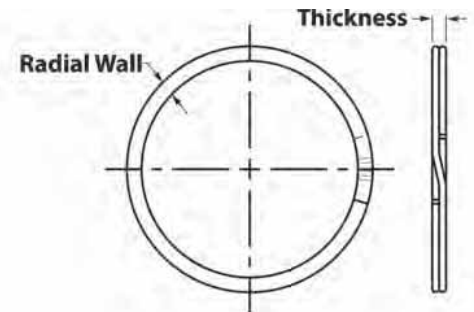

**Product Dimensions** All dimensions in millimeters unless otherwise specified.

Bore Shaft D	Groove <sup>2</sup> Width		Ring Dimensions		Groove Diameter D2	Groove Diameter D1		
	A	B	RW	T				
15	-	24.9	2.9	4.3	1.0	1.30	(D) +2.6	(D) -2.6
25	-	29.9	2.9	4.3	1.2	1.30	+3.0	-3.0
30	-	35.9	2.9	4.3	1.5	1.30	+3.6	-3.6
36	-	42.9	2.9	4.3	1.8	1.30	+4.2	-4.2
43	-	48.9	3.2	4.8	2.2	1.45	+5.0	-5.0
49	-	51.9	3.2	4.8	2.4	1.45	+5.4	-5.4
52	-	59.9	3.2	4.8	2.6	1.45	+5.8	-5.8
60	-	69.9	3.6	5.4	2.8	1.65	+6.2	-6.2
70	-	74.9	3.6	5.4	3.1	1.65	+6.8	-6.8
75	-	79.9	3.6	5.4	3.3	1.65	+7.2	-7.2
80	-	89.9	3.6	5.4	3.5	1.65	+7.6	-7.6
90	-	99.9	3.6	5.4	3.8	1.65	+8.2	-8.2
100	-	104.9	3.6	5.4	4.1	1.65	+8.8	-8.8
105	-	109.9	4.3	6.4	4.3	1.96	+9.2	-9.2
110	-	119.9	4.3	6.4	4.6	1.96	+9.8	-9.8
120	-	129.9	4.3	6.4	5.0	1.96	+10.8	-10.8
130	-	149.9	4.3	6.4	5.5	1.96	+11.8	-11.8
150	-	170.9	4.4	6.5	6.0	2.00	+13.0	-13.0
150 <sup>1</sup>	-	170.9	6.5	9.6	6.0	3.00	+13.0	-13.0
171	-	199.9	4.4	6.5	7.0	2.00	+15.0	-15.0
171 <sup>1</sup>	-	199.9	6.5	9.6	7.0	3.00	+15.0	-15.0
200	-	259.9	5.3	7.8	8.0	2.40	+18.0	-18.0
200 <sup>1</sup>	-	259.9	6.5	9.6	8.0	3.00	+18.0	-18.0
260	-	319.9	6.5	9.6	9.0	3.00	+20.0	-20.0
320	-	399.9	6.6	9.8	10.0	3.00	+22.0	-22.0
400	-	439.9	6.6	9.8	11.0	3.00	+24.0	-24.0
440	-	600.9	6.6	9.8	12.0	3.00	+26.0	-26.0
440 <sup>1</sup>	-	600.9	10.6	15.9	12.0	5.00	+26.0	-26.0
601	-	699.9	10.8	16.2	14.0	5.00	+32.0	-32.0
700	-	799.9	10.8	16.2	16.0	5.00	+36.0	-36.0
800	-	899.9	11.0	16.5	18.0	5.00	+40.0	-40.0
900	-	999.9	11.0	16.5	20.0	5.00	+44.0	-44.0
1000	-	1300.0	11.0	16.5	22.0	5.00	+48.0	-48.0

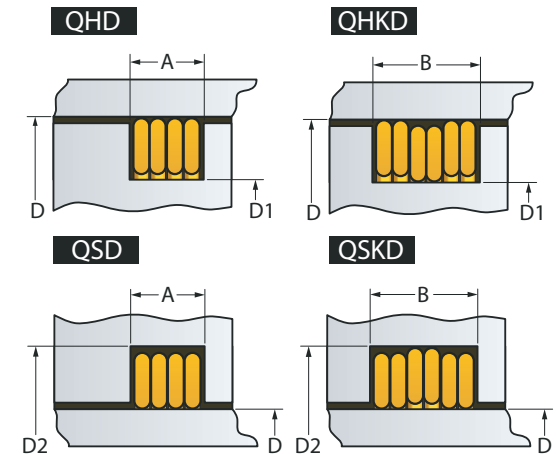

Tolerances (mm)				
D	15 - 104.9	105 - 149.9	150 - 439.9	440 - 1300
A-B	+0.10 -0.00	+0.15 -0.00	+0.20 -0.00	+0.25 -0.00
RW	+0.10 -0.10	+0.10 -0.20	+0.15 -0.30	+0.20 -0.40
T	+0.08 -0.04	+0.10 -0.06	+0.12 -0.08	+0.14 -0.10
D2	+0.20 -0.00	+0.25 -0.00	+0.30 -0.00	+0.40 -0.00
D1	+0.00 -0.20	+0.00 -0.25	+0.00 -0.30	+0.00 -0.40

<sup>1</sup> Increased cross-section.

<sup>2</sup> If axial movement occurs during operation, an increase to Groove Width may be necessary to avoid friction between Rings and Groove.