

SKF SPEEDI-SLEEVE

and large diameter wear sleeves





The SKF brand now stands for more than ever before, and means more to you as a valued customer.

While SKF maintains its leadership as the hallmark of quality bearings throughout the world, new dimensions in technical advances, product support and services have evolved SKF into a truly solutions-oriented supplier, creating greater value for customers.

These solutions encompass ways to bring greater productivity to customers, not only with breakthrough application-specific products, but also through leading-edge design simulation tools and consultancy services, plant asset efficiency maintenance programmes, and the industry's most advanced supply management techniques.

The SKF brand still stands for the very best in rolling bearings, but it now stands for much more.

SKF – the knowledge engineering company

Contents

3	The SKF SPEEDI-SLEEVE concept
4	The characteristics
5	SKF SPEEDI-SLEEVE Gold
6	Installing an SKF SPEEDI-SLEEVE
8	Product tables
8	Metric dimensions
20	Inch dimensions
32	Large diameter wear sleeves
34	Product tables
34	Metric dimensions
36	Inch dimensions
42	SKF – the knowledge engineering company

The SKF SPEEDI-SLEEVE concept

The fast and easy solution to worn shafts

To seal efficiently, radial shaft seals must run against a smooth, round surface – the seal counterface. If the counterface becomes worn, the seal will no longer be able to fulfil its function, which is to retain lubricant and to exclude contaminants.

Typically, the counterface becomes scored when a contaminant particle is caught under the seal lip and abrades a track as the shaft rotates. As this continues, the seal will allow more particles to pass or get stuck, and seal

efficiency deteriorates, eventually leading to malfunction of the component that the seal is meant to protect. To rectify the situation, it is necessary to repair the shaft surface since a simple seal replacement will not be sufficient. To repair the shaft, it is usually necessary to disassemble the machine in order to either replace the shaft with a new one or to be able to grind down the counterface until it is within specification again. However, if the grooves are deep, metal must first be added and then the shaft has to be ground down to restore the original diameter. Otherwise a new seal will not function properly.

However, there is an easy solution to this problem that allows the shaft to be held in position and does not require you to specify a different seal size. The solution is the SKF SPEEDI-SLEEVE from SKF.

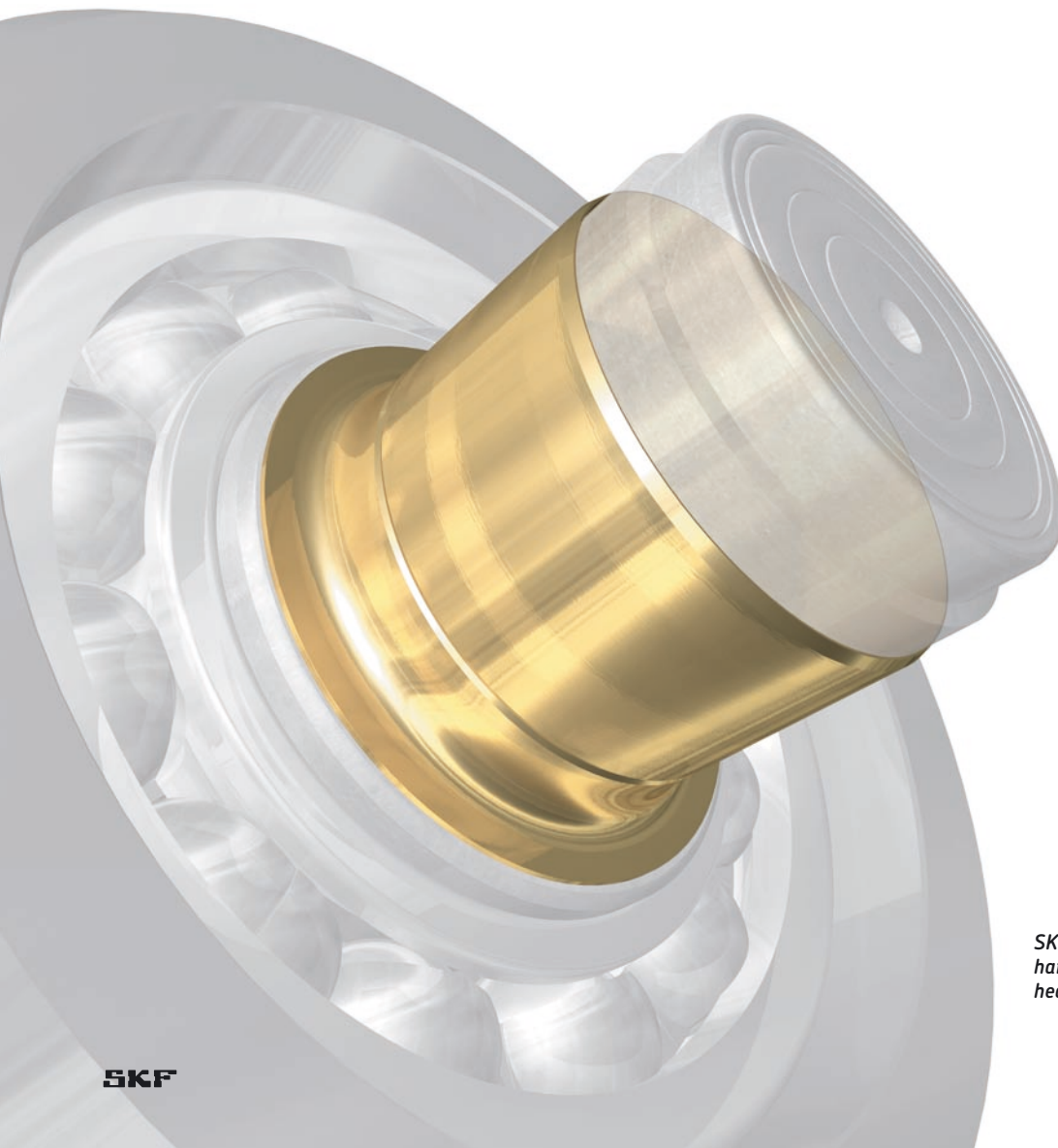

SKF SPEEDI-SLEEVE Gold with a surface hardness between 80 and 85 HRC for heavy-duty applications

The characteristics

A simple idea with an impressive effect

The SKF SPEEDI-SLEEVE has been developed by SKF to solve the problem of worn seal counterfaces at shaft ends. This thin-walled sleeve has a high quality finish to provide an optimal counterface for a radial shaft seal. The sleeve is simply pushed in position over the worn area providing a sealing surface that is as good as a new shaft, if not better.

There is no shaft disassembly or machining involved and costly downtime is minimized. Since the same sized seal as the original can be used, there is no need to search for other seals, or keep a stock of different sizes, which also results in time saved.

No special equipment is required since the installation tool is supplied with the sleeve. A mallet and a pair of pliers are all that is needed for the installation.

Features

The SKF SPEEDI-SLEEVE is thin-walled, 0,28 mm (0.011 in), and made of high quality stainless steel. The contact surface is wear-resistant and machined to minimize directionality ($0^\circ \pm 0,05$) with a finish of R_a 0,25 to 0,5 μm (10 to 20 μin), depending on size. This is, in fact, a better counterface than can often be achieved on a shaft. The SKF SPEEDI-SLEEVE has a removable flange to simplify the installation (\rightarrow fig. 1). The flange can most often be left intact, but in applications where the flange will interfere with other system components it should be removed not to cause friction heat and wear debris. The flange should also be removed in applications where it may reduce the circulation of the lubricant to the seal. This would cause reduced cooling effect of the lubricant, resulting in elevated underlip temperature and premature ageing of the seal material.

If the flange is to be removed, it should be cut from the outside diameter into the radius in one location prior to installation. The flange can then be rotated and raised up after installation and grasped with a pliers and twisted into a coil.

Size range

The standard size range covers shaft diameters from 11,91 to 203,33 mm (0.472 to 8 in). Depending on production quantities, non-standard sizes can be produced. Each sleeve, metric or inch, is designed to fit a specific shaft range, usually above and below the nominal shaft diameter. This permits some flexibility to accommodate variations in the actual shaft size.

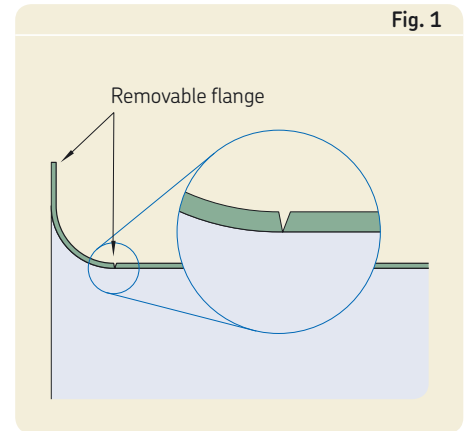

SKF SPEEDI-SLEEVE removable flange



SKF SPEEDI-SLEEVE
Gold – as good as a
new shaft, if not better

SKF SPEEDI-SLEEVE Gold

The preferred choice for harsh service conditions

SKF SPEEDI-SLEEVE Gold is an enhanced version of the standard SKF SPEEDI-SLEEVE, offering improved resistance to abrasive wear. Designed to be used in applications where extended sealing system life is needed, SKF SPEEDI-SLEEVE Gold bridges the performance gap between the standard sleeve and expensive custom shaft treatments. A thin, metallic film applied to the base stainless steel imparts a gold colour and significantly increases durability and surface hardness to approximately 2 300 Vickers¹⁾ or 80 to 85 HRC. The SKF SPEEDI-SLEEVE Gold is particularly effective in environments where there are abrasive contaminants, especially when combined with a seal manufactured in the SKF fluoro rubber material LongLife.

The installation procedure is identical to that of a standard SKF SPEEDI-SLEEVE and the original seal size can still be used.

Test results

The SKF SPEEDI-SLEEVE Gold has been thoroughly tested to establish its level of abrasion resistance in severely contaminated environments using both coarse and fine sand (→ **diagram 1**). The tests were carried out at temperatures up to 110 °C (225 °F) and at shaft speeds of up to 8,6 m/s (1 693 ft/min). Under these conditions, seals on shafts without SKF SPEEDI-SLEEVE Gold protection started to leak after 450 hours on average. Seals on SKF SPEEDI-SLEEVE Gold ran for an average of 2 500 hours.

In other tests it was found that continuous salt spray at 35 °C (95 °F) produced no trace of corrosion even after 600 hours.

Size range and availability

SKF SPEEDI-SLEEVE Gold is available from stock in a selection of common sizes. Other sizes up to 203,2 mm (8 in) can be produced to special order.



SKF SPEEDI-SLEEVE Gold

Diagram 1

Average wear resistance

Testing in highly abrasive conditions demonstrates how the hardened surface of SKF SPEEDI-SLEEVE Gold resists wear

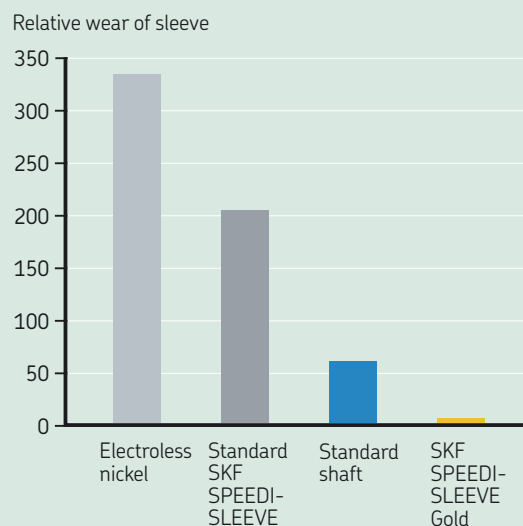

¹⁾ Due to the thin wall construction of SKF SPEEDI-SLEEVE, this can only be accurately measured using highly specialized instruments and methods

Installing an SKF SPEEDI-SLEEVE

A new seal counterface in a few minutes

Although installation is simple, it should be done carefully to achieve the best results. As the thin-walled sleeve has an interference fit, any disturbances on the shaft surface may create a similar pattern on the sleeve surface and the seal will leak. Therefore, the seal counter surface of the shaft should be carefully cleaned and any burrs or rough spots should be filed down prior to installation. Deep wear grooves, scratches or very rough surfaces should be treated with a suitable powdered metal epoxy filler. The sleeve must be positioned on the shaft before the filler has hardened.

An SKF SPEEDI-SLEEVE must not be installed over keyways, cross holes, splines or threads since this will result in deformation of the sleeve, making it difficult for the seal to follow its new counter surface as it rotates.

It should also be noted never to heat an SKF SPEEDI-SLEEVE prior to installation. Using heat will cause the sleeve to expand, but when it cools, it may not contract back to its original size, resulting in a loose fit on the shaft.

See **fig. 2** for different SKF SPEEDI-SLEEVE installations.

Choosing the right size

To determine the appropriate sleeve size it is first necessary to clean the shaft carefully. The diameter of an undamaged section of the seal counterface should then be measured on at least three different planes. The arithmetical mean of these measurements determines the size of the SKF SPEEDI-SLEEVE. If the value lies within the permissible range shown in the product table for the shaft diameter d_1 , the SKF SPEEDI-SLEEVE will have an adequately tight fit on the shaft and will not require an adhesive.

If no suitable sleeve is listed in the product table, it will be necessary to rework the shaft to an appropriate dimension. This also means that a new size of seal will be required. If production quantities are sufficient enough, SKF can provide a specially dimensioned SKF SPEEDI-SLEEVE or other wear sleeve solution.

SKF SPEEDI-SLEEVE installations

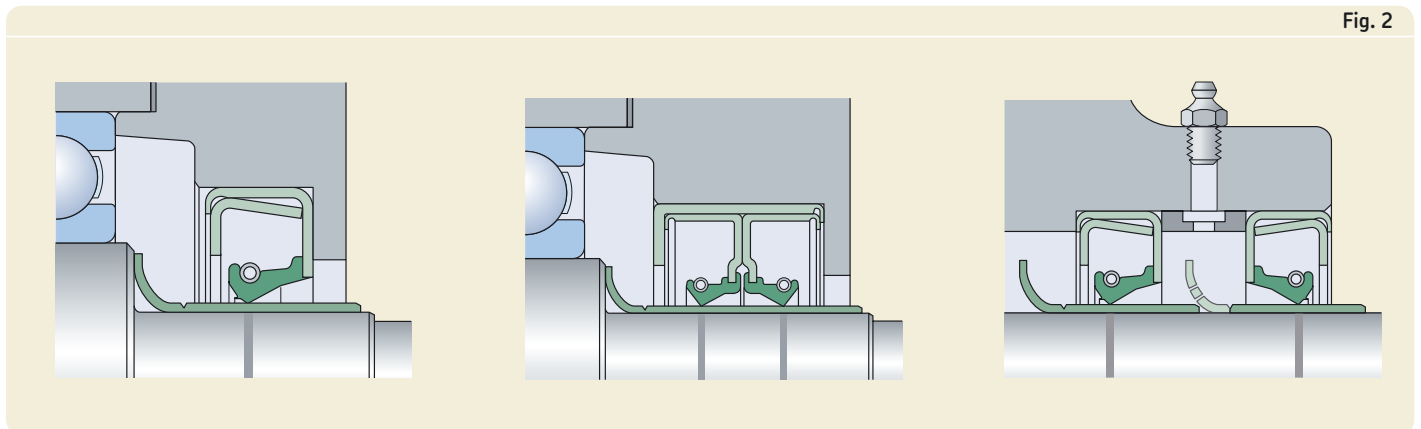
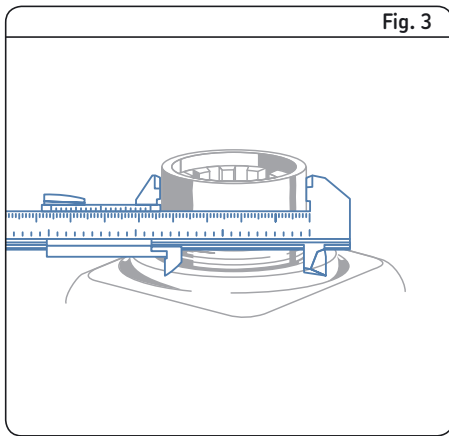
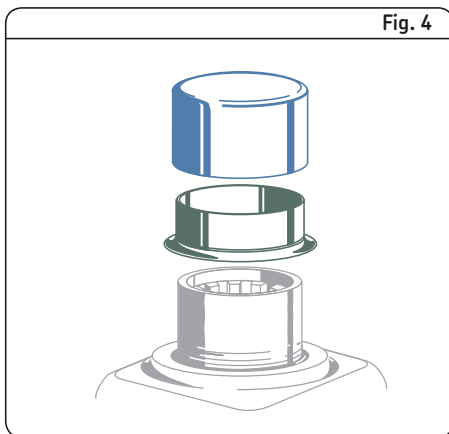

Fig. 2



Clean and measure the diameter of the worn shaft and mark the area where the sleeve will cover the scored portion of the shaft.



Place the SKF SPEEDI-SLEEVE on the shaft and then place the special installation tool over the sleeve.

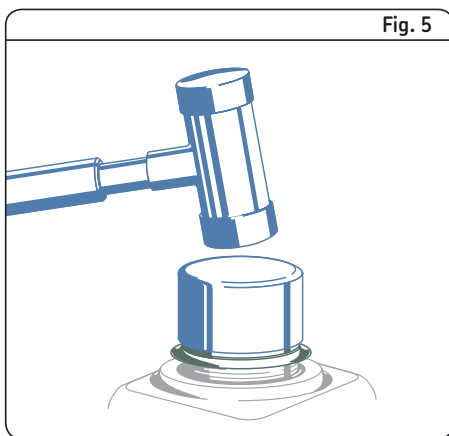

Tap the installation tool with a mallet until the sleeve is seated on the shaft over the marked area. Remove the installation tool.

Installation procedure

1. Clean the seal counter surface on the shaft. File down any burrs or rough spots and make sure that the sleeve will not be installed over keyways, cross holes, splines or similar.
2. Measure the diameter where the sleeve will be positioned on an unworn portion of the shaft (→ **fig. 3**). Measure in three positions and average the readings (to make sure the shaft is within recommended specifications). If the mean diameter is within the range for a given sleeve size, there is sufficient press fit built into the sleeve to prevent it from sliding or spinning without using an adhesive.
3. Determine where the sleeve must be positioned to cover the seal wear track. Measure to the exact point, or mark directly on the surface. The sleeve must be placed over the worn area, not just bottomed or left flush with the end of the shaft.
4. Shallow wear grooves do not require filling. Optionally, a light layer of a non-hardening sealant can be applied to the inside diameter surface of the sleeve. Clean away sealant that migrates to the shaft or sleeve outside diameter surface.
5. If the shaft is deeply scored (see note above) fill the groove with a powdered metal epoxy type filler. Install the sleeve before the filler hardens, allowing the sleeve to wipe off any excess filler. Clean away any remaining filler from the sleeve outside diameter surface.
6. It should be noted that heat may never be used to install an SKF SPEEDI-SLEEVE.
7. If the flange should be removed after installation, cut it from the outside diameter into the radius in one location. The flange end of the sleeve goes on the shaft first. Then place the installation tool over the sleeve (→ **fig. 4**).
8. Gently tap the centre of the installation tool until the sleeve covers the seal worn surface (→ **fig. 5**). If the installation tool is too short, a length of pipe or tubing with a squared-off, burr-free end can be used. Be sure that the inside diameter of the pipe is the same as that of the installation tool. Use care not to scratch the precision ground sleeve outside diameter.

9. An SKF SPEEDI-SLEEVE should always be installed so that the outside edge of the sleeve is seated on the full shaft diameter. It must not rest outside the chamfer area since the sharp edge will likely cut the seal lip during seal installation.
10. If the flange was cut for removal, use a longnose pliers to grasp the flange away from the seal surface and twist it into a coil being careful not to lift the end of the sleeve off the shaft or it will leave a jagged edge. Flange removal must be done with care to avoid damage to the sleeve outside diameter.
11. After the sleeve is installed, check again for burrs that could damage the seal.
12. Lubricate the sleeve with the system medium before installing the seal.
13. Proceed with the seal installation.

Removing an SKF SPEEDI-SLEEVE

An SKF SPEEDI-SLEEVE can be removed by applying heat to the sleeve with an electric heat blower, which will expand it enough to let it slide off the shaft without causing damage.

Alternatively, the sleeve can be removed in any of the following ways, always using care not to damage the shaft surface

- by relieving the press fit tension using a small hammer to peen across the full width of the sleeve
- by using a cold chisel to cut through the sleeve
- by using a pair of wire cutters starting at or near the flange and applying a twisting motion.

Please note that an SKF SPEEDI-SLEEVE cannot be reused.

SKF SPEEDI-SLEEVE – metric dimensions

d_1 11,91 – 34,01 mm

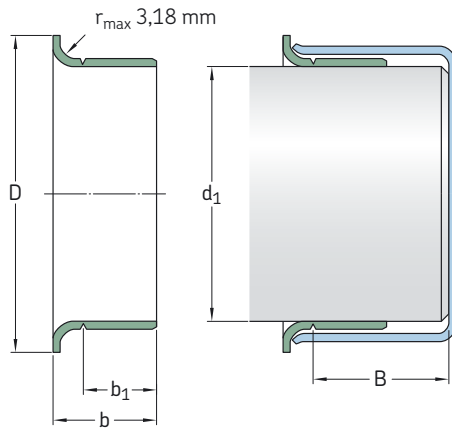

Shaft diameter range

Nominal dimensions

Designation

d_1 min	max	d_1	D $\pm 1,6$	b_1 $\pm 0,8$	b $\pm 0,8$	$B^{1)}$	
mm		mm					–
11,91	12,07	12,00	15,50	6,00	8,40	47,60	CR 99049
12,65	12,75	12,70	19,05	6,35	9,93	46,51	CR 99050
13,89	14,00	14,00	19,05	6,35	9,93	46,51	CR 99055
14,22	14,38	14,30	19,05	6,35	9,93	46,51	CR 99056
14,96	15,06	15,00	19,05	5,00	8,99	47,29	CR 99059
15,83	15,93	15,88	19,05	7,95	10,31	50,80	CR 99062
		15,88	19,05	7,95	10,31	50,80	CR 99810 *
15,89	16,00	16,00	18,24	7,95	11,10	50,80	CR 99058
16,94	17,04	17,00	22,23	7,95	11,00	50,80	CR 99068
17,32	17,42	17,37	22,86	7,95	11,13	50,80	CR 99060
17,87	18,00	18,00	24,43	8,00	11,00	46,00	CR 99082
19,00	19,10	19,00	24,00	7,95	11,13	50,80	CR 99811 *
		19,00	24,00	7,95	11,13	50,80	CR 99076
19,27	19,33	19,30	23,83	7,95	11,13	50,80	CR 99081
19,81	19,91	19,86	23,75	7,95	11,13	50,80	CR 99080
19,94	20,04	20,00	23,62	8,00	11,00	50,80	CR 99078
20,62	20,70	20,65	20,65	9,52	14,30	76,20	CR 99083
21,77	21,87	21,82	29,34	6,35	9,52	50,80	CR 99086
21,87	22,00	22,00	30,20	6,58	9,09	47,09	CR 99084
		22,00	30,17	8,00	11,99	46,05	CR 99085
22,18	22,28	22,23	27,79	7,95	11,13	50,80	CR 99812 *
		22,23	27,79	7,95	11,13	50,80	CR 99087
23,06	23,16	23,11	30,94	7,95	11,13	46,91	CR 99091
		23,11	30,94	7,95	11,13	46,91	CR 99860 *
23,87	24,00	24,00	28,70	7,95	11,10	50,80	CR 99092
24,54	24,64	24,59	28,70	15,88	18,26	50,80	CR 99096
		24,59	28,70	7,95	11,13	50,80	CR 99094

* Indicates SKF SPEEDI-SLEEVE Gold

¹⁾ Possible max. distance of the rear groove from the shaft end when the installation tool supplied with the sleeve is used

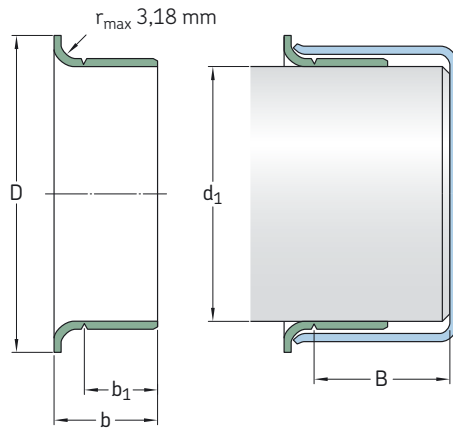

Shaft diameter range		Nominal dimensions					Designation
d_1 min	max	d_1	D $\pm 1,6$	b_1 $\pm 0,8$	b $\pm 0,8$	$B^{1)}$	
mm		mm					–
24,94	25,04	25,00	33,02	7,95	11,00	50,80	CR 99098
		25,00	33,02	7,95	11,00	50,80	CR 99813 *
25,35	25,45	25,40	30,96	7,95	11,13	50,80	CR 99814 *
		25,40	30,96	7,95	11,13	50,80	CR 99100
25,88	26,01	26,00	33,35	8,00	11,99	46,05	CR 99103
26,92	27,02	27,00	33,53	7,95	11,13	46,81	CR 99106
		27,00	33,53	7,95	11,13	46,81	CR 99815 *
27,61	27,71	27,66	35,71	7,95	11,13	15,88	CR 99108
27,94	28,04	28,00	34,92	9,52	12,70	46,81	CR 99111
		28,00	34,92	9,52	12,70	46,81	CR 99866 **
28,53	28,63	28,58	38,10	7,95	11,13	17,48	CR 99816 *
		28,58	38,10	7,95	11,13	17,48	CR 99112
		28,58	38,10	9,52	12,70	17,48	CR 99116
29,31	29,41	29,36	34,29	9,52	12,70	17,48	CR 99120
		29,36	34,29	9,52	12,70	17,48	CR 99865 **
29,80	29,93	29,85	35,56	7,95	11,13	17,48	CR 99122
29,95	30,08	30,00	35,56	8,00	11,00	17,48	CR 99114
30,10	30,23	30,15	35,56	7,95	11,13	17,48	CR 99118
30,88	31,04	31,00	39,70	7,95	11,00	15,88	CR 99123
31,42	31,58	31,50	39,12	8,00	11,10	17,48	CR 99141
31,67	31,83	31,75	38,10	7,95	11,13	17,48	CR 99125
		31,75	38,10	7,95	11,13	17,48	CR 99817 *
31,92	32,08	32,00	38,10	8,00	11,13	17,48	CR 99128
32,94	33,04	33,00	40,49	15,01	18,00	20,65	CR 99121
33,22	33,38	33,30	40,64	6,35	9,50	20,65	CR 99129
33,27	33,43	33,35	40,49	12,70	15,88	20,65	CR 99131
		33,35	40,49	12,70	15,90	20,65	CR 99818 **
33,86	34,01	34,00	41,28	12,70	15,90	20,70	CR 99134

* Indicates SKF SPEEDI-SLEEVE Gold

** Indicates SKF SPEEDI-SLEEVE Gold – contact SKF for availability

¹⁾ Possible max. distance of the rear groove from the shaft end when the installation tool supplied with the sleeve is used

SKF SPEEDI-SLEEVE – metric dimensions

d_1 34,82 – 48,64 mm

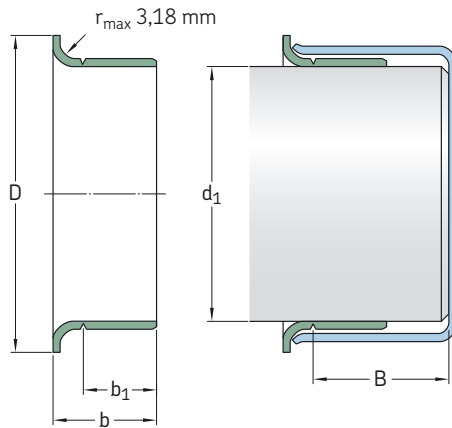

Shaft diameter range		Nominal dimensions					Designation
d_1 min	max	d_1	D $\pm 1,6$	b_1 $\pm 0,8$	b $\pm 0,8$	$B^{1)}$	
mm		mm					–
34,82	34,98	34,90	41,60	7,95	11,13	20,65	CR 99133
		34,90	41,60	12,70	15,88	20,65	CR 99138
		34,92	41,60	12,70	15,88	20,65	CR 99819 *
34,92	35,08	35,00	41,60	13,01	16,00	20,65	CR 99139
		35,00	41,60	13,01	16,00	20,65	CR 99820 *
35,85	36,00	36,00	45,24	13,01	16,99	24,99	CR 99146
36,37	36,53	36,45	45,24	14,30	17,48	25,81	CR 99143
		36,53	45,24	14,30	17,48	25,81	CR 99821 *
36,45	36,61	36,53	45,24	9,52	12,70	25,81	CR 99144
37,85	38,00	38,00	45,24	13,01	16,99	24,99	CR 99147
38,02	38,18	38,10	45,24	9,52	12,70	25,81	CR 99150
		38,10	45,24	14,30	17,48	25,81	CR 99149
		38,10	45,24	9,52	12,70	25,81	CR 99823 *
		38,10	45,24	14,30	17,48	25,81	CR 99822 *
38,60	38,76	38,68	47,22	11,13	14,30	25,81	CR 99152
39,34	39,50	39,42	47,22	11,13	14,30	25,81	CR 99155
39,59	39,75	39,70	47,22	14,30	17,48	25,81	CR 99824 *
		39,67	47,22	14,30	17,48	25,81	CR 99156
39,77	39,93	39,85	47,22	15,88	19,05	25,81	CR 99159
39,84	40,00	40,00	46,99	9,91	12,93	25,40	CR 99153
39,93	40,08	40,00	46,99	13,01	16,00	25,98	CR 99825 *
	40,09	40,00	46,99	13,01	16,00	25,98	CR 99157
40,69	40,85	40,77	49,22	12,70	16,28	25,40	CR 99160
40,84	41,00	41,00	49,20	12,70	15,88	25,81	CR 99163
		41,28	47,63	14,30	17,48	20,65	CR 99826 *
		41,28	47,63	7,95	11,13	25,81	CR 99161
	41,36	41,28	47,63	14,30	17,48	20,65	CR 99162
41,84	42,00	42,00	53,01	11,30	14,50	21,49	CR 99166
		42,00	53,01	14,00	18,00	21,01	CR 99873 **
		42,00	53,01	14,30	17,50	21,01	CR 99169

* Indicates SKF SPEEDI-SLEEVE Gold

** Indicates SKF SPEEDI-SLEEVE Gold – contact SKF for availability

¹⁾ Possible max. distance of the rear groove from the shaft end when the installation tool supplied with the sleeve is used

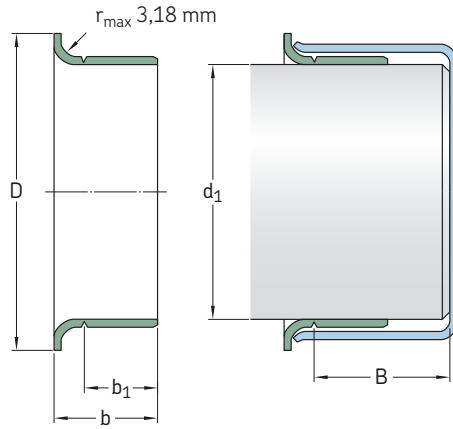

Shaft diameter range Nominal dimensions Designation

d ₁ min	max	d ₁	D ±1,6	b ₁ ±0,8	b ±0,8	B ¹⁾	
mm		mm					-
41,98	42,14	42,06	53,01	13,97	17,50	21,01	CR 99165
42,78	42,93	42,85	48,41	14,30	17,48	22,23	CR 99168
42,80	42,96	42,88	48,41	7,95	11,13	22,23	CR 99167
42,84	43,00	43,00	48,41	12,70	15,88	21,41	CR 99182
43,56	43,72	43,64	51,59	14,30	17,48	20,65	CR 99171
44,09	44,25	44,17	52,40	9,52	12,70	20,65	CR 99170
44,37	44,53	44,45	52,20	9,52	12,70	20,65	CR 99172
		44,45	52,40	13,49	15,88	22,23	CR 99180
		44,45	52,40	14,30	17,48	20,65	CR 99174
		44,45	52,40	19,05	22,23	20,65	CR 99175
		44,45	52,40	14,30	17,48	20,65	CR 99827 *
		44,45	52,40	19,05	22,23	20,65	CR 99828 *
44,73	44,88	44,86	52,40	14,30	17,48	20,65	CR 99829 *
	44,89	44,81	53,01	13,99	16,99	20,65	CR 99176
44,93	45,09	45,00	53,01	13,99	16,99	20,63	CR 99177
	45,08	45,00	53,97	16,87	20,32	26,98	CR 99830 *
45,16	45,32	45,24	53,09	14,30	17,48	25,40	CR 99179
45,94	46,10	46,05	53,09	14,30	17,48	25,40	CR 99181
45,95	46,10	46,05	54,76	14,30	17,48	25,40	CR 99831 **
47,16	47,32	47,24	55,58	22,58	17,48	25,40	CR 99185
47,39	47,55	47,45	55,95	22,58	26,03	25,40	CR 99186
47,55	47,70	47,63	55,96	14,30	17,48	25,40	CR 99832 *
	47,71	47,63	55,96	4,45	7,49	18,90	CR 99190
		47,63	55,96	7,49	10,54	18,90	CR 99188
		47,63	55,96	9,53	13,11	26,67	CR 99184
		47,63	55,96	14,30	17,48	25,40	CR 99187
47,93	48,09	48,00	56,01	14,00	16,97	24,99	CR 99189
48,48	48,64	48,56	56,36	9,53	12,70	25,40	CR 99192

* Indicates SKF SPEEDI-SLEEVE Gold

** Indicates SKF SPEEDI-SLEEVE Gold – contact SKF for availability

¹⁾ Possible max. distance of the rear groove from the shaft end when the installation tool supplied with the sleeve is used

SKF SPEEDI-SLEEVE – metric dimensions

d₁ 49,12 – 69,42 mm

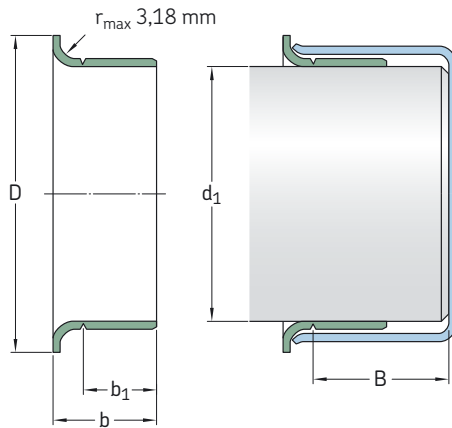

Shaft diameter range		Nominal dimensions					Designation
d ₁ min	max	d ₁	D ±1,6	b ₁ ±0,8	b ±0,8	B ¹⁾	
mm		mm					–
49,12	49,28	49,20	56,36	14,30	17,48	25,40	CR 99193
		49,22	56,36	14,30	17,48	25,40	CR 99833 *
49,91	50,07	50,00	57,00	14,00	17,00	24,99	CR 99196
50,21	50,37	50,30	58,75	14,30	17,88	26,67	CR 99198
50,72	50,88	50,80	61,11	14,30	17,48	25,40	CR 99199
		50,80	61,11	22,23	25,40	25,40	CR 99200
		50,80	61,11	14,30	17,48	25,40	CR 99834 *
		50,80	61,11	22,23	25,40	25,40	CR 99835 *
51,81	52,00	52,00	62,71	12,70	15,88	34,52	CR 99204
52,24	52,40	52,32	62,71	19,84	23,83	34,93	CR 99205
53,92	54,06	54,00	61,52	12,70	19,05	32,54	CR 99210
53,95	54,10 54,11	54,00	61,52	19,84	23,83	34,92	CR 99836 *
		54,00	61,52	19,84	23,83	34,93	CR 99212
54,91	55,07	54,99	62,00	19,99	22,99	31,75	CR 99863 *
		55,00	62,00	19,99	22,99	31,75	CR 99215
55,52	55,68	55,60	63,50	19,84	23,83	33,35	CR 99218
55,81	56,00	56,00	64,29	19,79	23,77	80,01	CR 99224
		56,00	64,29	12,70	15,88	33,35	CR 99220
56,56	56,72	56,64	64,29	12,70	15,88	33,35	CR 99229
		56,64	64,29	19,84	23,01	31,75	CR 99230
56,57	56,72	56,64	64,29	12,70	15,88	33,35	CR 99861 **
56,82	56,98	56,90	65,10	19,41	22,86	31,75	CR 99226
57,12	57,28	57,15	64,29	19,84	23,83	33,35	CR 99837 *
		57,20	64,29	7,95	11,13	33,35	CR 99227
		57,20	64,29	19,84	23,83	33,35	CR 99225
57,13	57,28	57,15	64,29	7,95	11,13	33,35	CR 99838 **
57,91	58,06	58,00	65,99	19,84	23,83	34,92	CR 99219
58,64	58,80	58,72	68,28	19,84	23,83	34,93	CR 99231
59,10	59,26	59,18	69,85	19,05	22,23	38,10	CR 99233

* Indicates SKF SPEEDI-SLEEVE Gold

** Indicates SKF SPEEDI-SLEEVE Gold – contact SKF for availability

¹⁾ Possible max. distance of the rear groove from the shaft end when the installation tool supplied with the sleeve is used

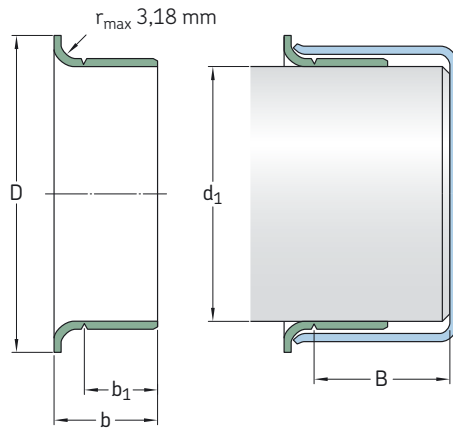

Shaft diameter range		Nominal dimensions					Designation
d_1 min	max	d_1	D $\pm 1,6$	b_1 $\pm 0,8$	b $\pm 0,8$	$B^{1)}$	
mm		mm					–
59,91	60,07	60,00	70,74	20,00	23,00	34,93	CR 99869 **
		60,00	70,74	20,00	23,00	34,93	CR 99235
59,92	60,08	60,00	70,74	9,40	11,43	37,36	CR 99241
60,25	60,41	60,33	69,85	15,09	19,05	34,93	CR 99238
60,30	60,46	60,38	69,85	13,36	17,35	34,93	CR 99240
		60,33	69,85	19,84	23,83	34,93	CR 99839 *
		60,38	69,85	19,84	23,83	34,93	CR 99237
61,81	62,00	62,00	71,83	12,70	15,88	36,20	CR 99244
61,82	61,98	61,90	71,83	19,84	23,83	35,38	CR 99243
61,85	62,01	62,00	71,83	12,70	15,88	36,20	CR 99242
63,22	63,38	63,30	73,03	19,84	23,83	35,38	CR 99249
63,42	63,58	63,50	71,63	14,10	16,51	22,61	CR 99253
63,50	63,65 63,66	63,50	71,63	19,84	23,83	34,92	CR 99840 *
		63,50	71,83	12,70	16,66	35,38	CR 99248
		63,50	71,63	19,84	23,83	34,93	CR 99250
63,75	63,91	63,83	71,83	19,84	23,01	36,53	CR 99251
64,92	65,08	65,00	72,39	19,99	22,99	34,93	CR 99254
		65,00	72,39	19,99	22,99	34,92	CR 99841 *
65,02	65,18	65,10	73,43	19,84	23,83	34,93	CR 99256
65,91	66,07	66,00	75,95	19,84	23,83	31,75	CR 99259
66,49	66,65	66,57	77,39	19,84	23,83	34,93	CR 99261
66,57	66,73	66,65	77,39	19,84	23,01	34,93	CR 99264
66,60	66,76	66,68	77,39	12,70	15,88	34,93	CR 99260
66,67	66,83	66,75	77,39	19,84	23,83	34,93	CR 99262
66,68	66,83	66,68	77,39	19,84	23,83	34,92	CR 99842 *
67,81	68,00	68,00	79,38	19,05	22,23	42,88	CR 99266
69,26	69,42	69,34	79,38	19,84	23,01	33,35	CR 99268

* Indicates SKF SPEEDI-SLEEVE Gold

** Indicates SKF SPEEDI-SLEEVE Gold – contact SKF for availability

¹⁾ Possible max. distance of the rear groove from the shaft end when the installation tool supplied with the sleeve is used

SKF SPEEDI-SLEEVE – metric dimensions

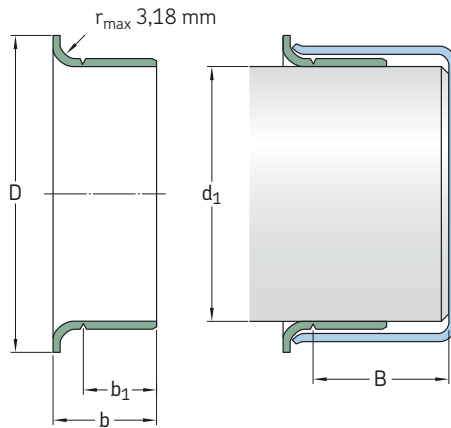
 d₁ 69,59 – 89,06 mm

Shaft diameter range		Nominal dimensions					Designation
d ₁ min	max	d ₁	D ±1,6	b ₁ ±0,8	b ±0,8	B ¹⁾	
mm		mm					–
69,59	69,75	69,67	77,85	19,84	23,83	31,75	CR 99273
69,72	69,88	69,80 69,85	79,38 79,38	19,84 19,84	23,83 23,83	31,75 31,75	CR 99274 CR 99843 *
69,77	69,93	69,85	78,11	36,53	41,28	41,28	CR 99267
69,85	70,00 70,01	70,00 70,00 70,00 70,00	79,38 79,38 79,38 79,38	19,84 10,31 19,84 28,58	23,83 14,30 23,83 31,75	31,75 31,75 31,75 33,32	CR 99844 * CR 99272 CR 99275 CR 99269
69,92	70,08	70,00	79,38	19,99	24,00	31,75	CR 99276
71,34	71,50	71,42	80,98	15,09	17,48	31,75	CR 99281
71,81	72,00	72,00 72,00	81,92 81,92	19,05 19,05	22,23 22,23	34,11 34,11	CR 99870 ** CR 99284
72,08	72,24	72,16 72,08	81,92 81,92	12,70 12,70	16,66 16,66	31,75 31,75	CR 99282 CR 99845 *
72,79	72,95	72,87	80,98	19,84	23,83	31,75	CR 99286
72,97	73,13	73,00 73,00	81,76 81,76	19,84 19,84	23,83 23,83	31,75 31,75	CR 99287 CR 99846 *
74,60	74,75 74,76	74,68 74,63 74,68	84,94 84,94 84,94	19,84 19,84 12,70	23,83 23,83 16,28	33,35 33,35 33,81	CR 99293 CR 99847 * CR 99290
74,93	75,09	75,00 75,00 75,00	83,13 83,95 83,95	15,09 22,00 22,00	17,53 26,01 26,01	27,51 33,35 33,35	CR 99289 CR 99875 ** CR 99294
75,49	75,59	75,54	82,17	20,62	25,40	31,75	CR 99292
75,94	76,10	76,02 76,00 76,00	85,32 85,32 85,09	12,29 14,30 20,65	15,88 17,48 25,40	33,81 34,93 32,54	CR 99291 CR 99298 CR 99299
76,12	76,28	76,20	82,30	20,65	23,83	34,93	CR 99296
76,20	76,36	76,28 76,20 76,28	84,96 82,17 82,17	15,88 20,65 20,65	20,65 25,40 25,40	32,51 32,54 32,54	CR 99303 CR 99848 * CR 99300

* Indicates SKF SPEEDI-SLEEVE Gold

** Indicates SKF SPEEDI-SLEEVE Gold – contact SKF for availability

1) Possible max. distance of the rear groove from the shaft end when the installation tool supplied with the sleeve is used

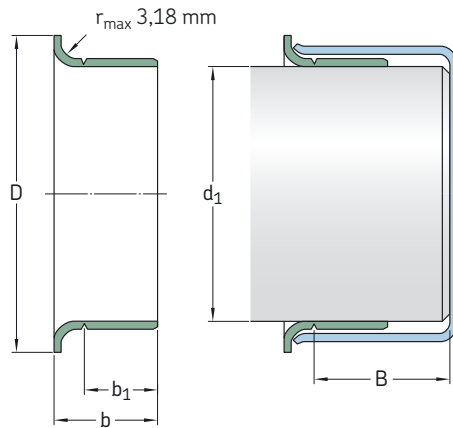

Shaft diameter range		Nominal dimensions					Designation
----------------------	--	--------------------	--	--	--	--	-------------

d_1 min	max	d_1	D $\pm 1,6$	b_1 $\pm 0,8$	b $\pm 0,8$	$B^{1)}$	
mm		mm					–
76,40	76,56	76,48	85,22	12,70	15,88	50,80	CR 99301
77,81	78,00	78,00	88,04	19,05	22,23	52,22	CR 99306
79,24	79,40	79,32	89,69	17,48	20,65	50,80	CR 99311
		79,38	89,69	20,65	25,40	50,80	CR 99849 *
		79,38	89,69	20,65	25,40	50,80	CR 99312
79,35	79,55	79,38	89,54	14,00	18,01	51,59	CR 99307
79,81	80,01	80,00	89,92	19,05	22,50	34,93	CR 99313
79,90	80,08	80,00	89,99	11,00	15,01	34,93	CR 99317
79,91	80,08	80,00	89,99	21,01	24,00	34,93	CR 99315
81,91	82,07	82,00	91,06	16,76	21,54	44,45	CR 99328
82,47	82,63	82,55	91,29	20,65	25,40	34,93	CR 99322
82,50	82,70	82,50	90,81	15,11	18,26	34,92	CR 99850 *
82,55	82,70 82,71	82,55	91,06	20,65	25,40	34,92	CR 99851 *
		82,63	90,81	15,11	18,26	34,93	CR 99324
		82,63	91,06	17,48	22,23	31,75	CR 99326
		82,63	91,06	20,65	25,40	34,93	CR 99325
84,00	84,15	84,00	93,68	20,65	25,40	34,93	CR 99331
84,76	85,02 85,00	85,00	93,98	16,99	21,00	35,00	CR 99332
		85,00	93,98	21,01	24,99	35,00	CR 99333
		85,00	90,93	10,13	12,67	36,35	CR 99334
84,88	85,02	85,00	93,98	21,01	24,99	35,00	CR 99872 *
85,67	85,83	85,75	93,67	9,53	12,70	35,81	CR 99338
		85,75	93,85	20,65	25,40	34,93	CR 99337
87,25	87,41	87,33	97,64	19,84	23,01	35,71	CR 99339
88,31	88,47	88,39	97,41	19,84	23,01	35,71	CR 99340
88,82	88,98	88,98	97,64	15,88	20,65	34,21	CR 99346
88,90	89,05 89,06	89,00	97,64	20,65	25,40	34,21	CR 99852 *
		89,00	97,16	7,95	12,70	34,21	CR 99347
		89,00	97,64	20,65	25,40	34,21	CR 99350

* Indicates SKF SPEEDI-SLEEVE Gold

¹⁾ Possible max. distance of the rear groove from the shaft end when the installation tool supplied with the sleeve is used

SKF SPEEDI-SLEEVE – metric dimensions

d₁ 88,92 – 125,10 mm

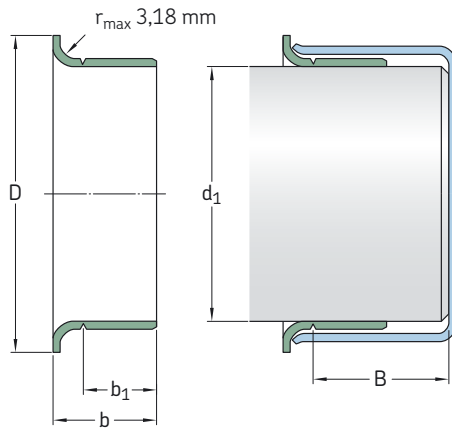

Shaft diameter range		Nominal dimensions					Designation
d ₁ min	max	d ₁	D ±1,6	b ₁ ±0,8	b ±0,8	B ¹⁾	
mm		mm					–
88,92	89,08	89,00	97,64	15,88	20,65	34,24	CR 99349
89,91	90,07	90,00	101,60	11,13	13,67	46,05	CR 99352
		90,00	101,60	13,36	16,94	44,45	CR 99353
		90,00	101,60	18,03	23,01	46,05	CR 99351
		90,00	101,60	23,01	27,99	44,45	CR 99354
90,42	90,58	90,50	99,06	20,65	25,40	44,45	CR 99356
91,89	92,05	92,00	102,39	20,65	25,40	44,45	CR 99360
92,02	92,18	92,10	102,24	12,70	15,87	44,45	CR 99363
		92,10	102,39	20,65	25,40	44,45	CR 99362
93,57	93,73	93,65	102,39	7,95	11,13	22,23	CR 99368
93,60	93,76	93,68	102,24	20,65	23,83	45,72	CR 99365
94,66	94,82	94,74	102,01	11,91	15,09	45,72	CR 99359
		94,74	102,24	19,84	23,01	45,72	CR 99366
94,92	95,08	95,00	102,24	21,01	24,00	45,72	CR 99369
94,99	95,15	95,00	102,39	8,74	12,70	45,72	CR 99374
		95,00	102,49	11,91	15,09	45,72	CR 99364
95,14	95,30	95,22	102,24	14,30	17,48	45,72	CR 99376
95,25	95,41	95,33	102,24	8,74	12,70	45,72	CR 99367
		95,25	102,11	17,48	22,23	45,72	CR 99853 *
		95,33	102,11	17,48	22,23	45,72	CR 99372
98,24	98,40	98,32	106,30	20,65	25,40	47,63	CR 99386
98,37	98,53	98,45	107,16	20,65	25,40	47,63	CR 99387
99,95	100,11	100,00	109,55	20,65	25,40	52,07	CR 99854 *
		100,00	109,55	20,65	25,40	52,07	CR 99393
101,55	101,75	101,60	111,13	20,65	25,40	52,07	CR 99855 *
		101,65	111,13	12,70	15,88	52,48	CR 99401
		101,65	111,13	15,24	18,42	52,07	CR 99395
		101,65	111,13	16,51	19,69	34,93	CR 99400
		101,65	111,13	20,65	25,40	52,07	CR 99399

* Indicates SKF SPEEDI-SLEEVE Gold

¹⁾ Possible max. distance of the rear groove from the shaft end when the installation tool supplied with the sleeve is used

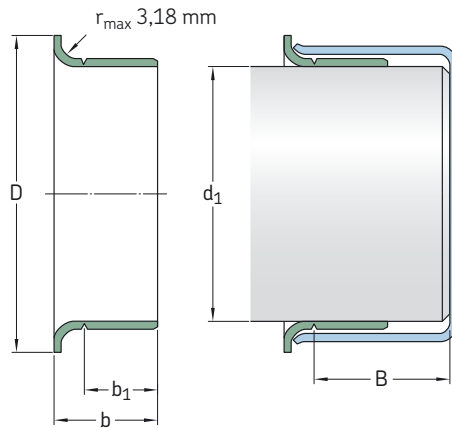

Shaft diameter range		Nominal dimensions					Designation
d_1 min	max	d_1	D $\pm 1,6$	b_1 $\pm 0,8$	b $\pm 0,8$	$B^{1)}$	
mm		mm					–
103,89	104,09	104,00	112,72	19,99	24,00	35,99	CR 99409
104,70	104,90	104,80	113,54	20,65	25,40	34,93	CR 99412
104,90	105,10	105,00	113,54	19,99	23,19	35,00	CR 99413
106,25	106,45	106,35	114,30	20,65	25,40	34,93	CR 99418
107,34	107,54	107,44	117,09	19,84	23,01	36,53	CR 99423
107,90	108,10	108,00	117,09	20,65	25,40	36,53	CR 99424
109,78	110,00	110,00	124,99	11,38	14,96	32,94	CR 99434
109,91	110,11	110,00	124,99	12,93	16,51	31,75	CR 99435
111,00	111,20	111,10	120,65	20,65	25,40	41,91	CR 99437
111,78	112,00	112,00	120,70	19,05	22,50	33,02	CR 99438
112,63	112,83	112,72	122,25	25,40	29,01	33,35	CR 99439
114,20	114,40	114,30 114,30	124,46 123,19	20,65 20,65	25,40 25,40	31,75 31,75	CR 99856 * CR 99450
114,89	115,09	115,00	127,00	20,65	23,83	31,75	CR 99452
117,38	117,58	117,48 117,48	127,00 128,60	11,13 25,40	15,88 31,75	34,93 34,93	CR 99465 CR 99463
119,00	119,20	119,00	128,60	20,65	25,40	34,93	CR 99468
119,89	120,09	120,00 120,00	129,79 129,79	8,00 19,99	11,00 24,99	33,60 32,00	CR 99471 CR 99473
120,55	120,75	120,65	127,00	12,70	19,05	38,10	CR 99475
121,90	122,10	122,00	131,49	19,99	24,00	32,00	CR 99472
122,91	123,11	123,00	132,82	19,99	24,99	31,60	CR 99484
123,73	123,93	123,83	133,35	15,88	19,05	36,53	CR 99487
124,89	125,09	125,00	137,16	26,01	32,00	36,53	CR 99492
124,90	125,10	125,00	137,16	10,00	14,00	36,53	CR 99490

* Indicates SKF SPEEDI-SLEEVE Gold

¹⁾ Possible max. distance of the rear groove from the shaft end when the installation tool supplied with the sleeve is used

SKF SPEEDI-SLEEVE – metric dimensions

d₁ 126,95 – 203,33 mm

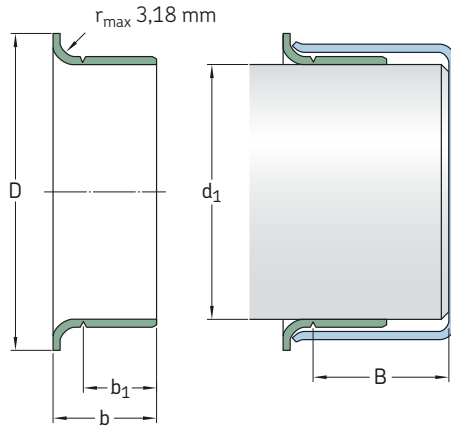

Shaft diameter range		Nominal dimensions					Designation
d ₁ min	max	d ₁	D ±1,6	b ₁ ±0,8	b ±0,8	B ¹⁾	
mm		mm					
126,95	127,15	127,00	137,16	17,48	22,23	36,53	CR 99857 *
		127,00	139,91	20,65	25,40	36,53	CR 99858 *
		127,00	137,16	13,72	17,30	36,53	CR 99501
		127,00	137,16	17,48	22,23	36,50	CR 99498
		127,00	136,91	20,65	25,40	36,53	CR 99499
129,80	130,00	130,00	139,52	19,05	23,83	30,00	CR 99494
129,97	130,17	130,00	139,52	22,00	25,30	32,51	CR 99874 **
		130,00	139,52	22,00	25,30	32,51	CR 99491
130,05	130,25	130,15	139,70	20,65	25,40	31,75	CR 99513
133,25	133,45	133,35	141,22	20,65	25,40	31,75	CR 99525
134,80	135,00	135,00	145,67	20,50	25,40	31,75	CR 99533
136,43	136,63	136,53	149,23	20,65	25,40	31,75	CR 99537
138,03	138,23	138,13	146,05	38,10	42,88	47,63	CR 99548
138,99	139,19	139,00	149,86	14,30	19,05	31,34	CR 99547
139,65	139,85	139,70	150,83	20,65	25,40	31,75	CR 99859 **
		139,75	150,83	13,16	17,91	31,75	CR 99550
		139,75	150,83	20,65	25,40	31,75	CR 99549
139,90	140,11	140,00	151,00	20,50	25,40	31,75	CR 99552
142,77	142,98	142,88	157,18	22,23	25,40	46,02	CR 99560
144,75	145,00	145,00	154,94	19,05	22,23	46,02	CR 99571
145,44	145,64	145,54	154,94	14,30	19,05	49,23	CR 99562
145,95	146,15	146,05	156,97	20,65	25,40	44,45	CR 99575
149,13	149,33	149,23	157,18	25,40	31,75	33,35	CR 99862 *
		149,23	157,18	25,40	31,75	33,35	CR 99587
149,75	150,00	150,00	159,00	26,01	30,00	32,51	CR 99595
150,73	150,93	150,83	161,93	25,40	28,58	47,63	CR 99596
152,27	152,47	152,37	161,54	12,70	19,05	44,45	CR 99601
		152,37	161,93	25,40	31,75	44,45	CR 99599

* Indicates SKF SPEEDI-SLEEVE Gold

** Indicates SKF SPEEDI-SLEEVE Gold – contact SKF for availability

¹⁾ Possible max. distance of the rear groove from the shaft end when the installation tool supplied with the sleeve is used

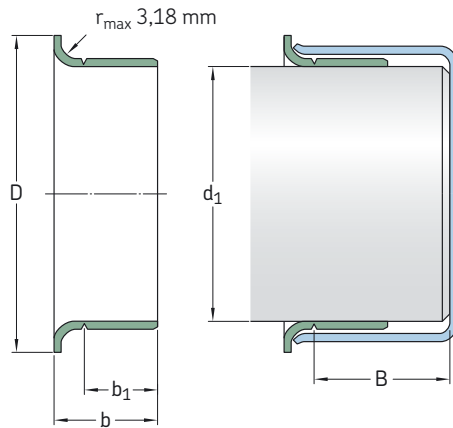

Shaft diameter range		Nominal dimensions					Designation
d_1 min	max	d_1	D $\pm 1,6$	b_1 $\pm 0,8$	b $\pm 0,8$	$B^{1)}$	
mm		mm					–
153,87	154,13	154,00	161,93	26,01	30,00	32,99	CR 99605
154,75	155,00	155,00	167,01	26,01	30,00	32,99	CR 99606
157,43	157,69	157,56	168,28	20,65	27,00	44,45	CR 99620
158,62	158,88	158,75	168,28	26,19	31,75	44,45	CR 99625
159,74	160,00	160,00	171,45	25,40	31,75	34,93	CR 99630
164,97	165,23	165,10	177,80	25,40	31,75	34,93	CR 99650
169,75	170,01	170,00	182,57	31,75	38,00	44,45	CR 99640
171,32	171,58	171,45	180,98	20,65	27,00	44,45	CR 99675
174,75	175,01	175,00	187,00	27,99	32,00	35,00	CR 99687
177,67	177,93	177,80 177,80	189,87 189,87	25,40 25,40	31,75 31,75	42,88 42,88	CR 99700 CR 99864 **
179,75	180,01	180,00	190,50	32,99	38,00	44,50	CR 99721
183,99	184,25	184,00	197,10	31,75	38,10	55,25	CR 99725
184,75	185,00	185,00	197,10	32,00	38,00	54,99	CR 99726
189,07	189,33	189,20	199,64	20,65	25,40	31,75	CR 99745
190,37	190,63	190,50	200,03	20,65	25,40	31,75	CR 99750
196,72	196,98	196,85	210,06	25,40	33,35	47,63	CR 99775
199,87	200,13	200,00	212,73	34,52	38,10	44,45	CR 99787
201,50	201,76	201,63	212,73	25,40	31,75	44,45	CR 99799
203,07	203,33	203,20	212,73	25,40	31,75	44,45	CR 99800

** Indicates SKF SPEEDI-SLEEVE Gold – contact SKF for availability

¹⁾ Possible max. distance of the rear groove from the shaft end when the installation tool supplied with the sleeve is used

SKF SPEEDI-SLEEVE – inch dimensions

d₁ 0.472 – 1.339 in

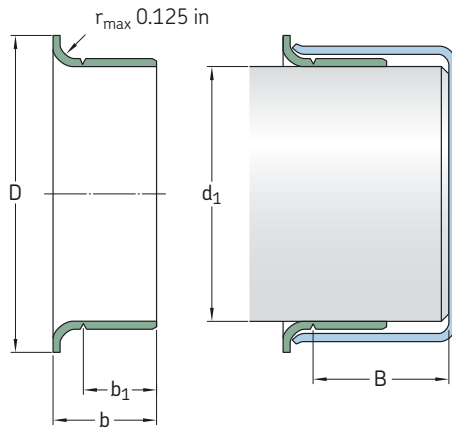

Shaft diameter range		Nominal dimensions					Designation
d ₁ min	max	d ₁	D ±0,063	b ₁ ±0,031	b ±0,031	B ¹⁾	
in		in					–
0.472	0.475	0.472	0.610	0.236	0.331	1.875	CR 99049
0.498	0.502	0.500	0.610	0.250	0.344	2.000	CR 99050
0.547	0.551	0.551	0.750	0.250	0.391	1.831	CR 99055
0.560	0.566	0.563	0.750	0.250	0.391	1.831	CR 99056
0.589	0.593	0.591	0.750	0.197	0.354	1.862	CR 99059
0.623	0.627 0.627	0.625 0.625	0.750 0.750	0.313 0.313	0.406 0.406	2.000 2.000	CR 99810 * CR 99062
0.626	0.630	0.630	0.718	0.313	0.438	2.000	CR 99058
0.667	0.671	0.669	0.875	0.315	0.433	2.000	CR 99068
0.682	0.686	0.684	0.900	0.313	0.438	2.000	CR 99060
0.704	0.709	0.709	0.962	0.315	0.433	1.811	CR 99082
0.748	0.752	0.750 0.750	0.945 0.945	0.313 0.313	0.438 0.438	2.000 2.000	CR 99811 * CR 99076
0.759	0.761	0.760	0.938	0.313	0.438	2.000	CR 99081
0.780	0.784	0.781	0.935	0.313	0.438	2.000	CR 99080
0.785	0.789	0.787	0.930	0.315	0.433	2.000	CR 99078
0.812	0.815	0.813	1.188	0.375	0.563	3.000	CR 99083
0.857	0.861	0.859	1.155	0.250	0.375	2.000	CR 99086
0.861	0.866	0.866 0.866	1.188 1.188	0.259 0.315	0.359 0.472	1.856 1.812	CR 99084 CR 99085
0.873	0.877	0.875 0.875	1.094 1.094	0.313 0.313	0.438 0.438	2.000 2.000	CR 99812 * CR 99087
0.908	0.912	0.910 0.910	1.218 1.218	0.313 0.313	0.438 0.438	1.847 1.847	CR 99860 * CR 99091
0.940	0.945	0.945	1.130	0.313	0.438	2.000	CR 99092
0.966	0.970	0.969 0.969	1.130 1.130	0.313 0.625	0.438 0.719	2.000 2.000	CR 99094 CR 99096

* Indicates SKF SPEEDI-SLEEVE Gold

¹⁾ Possible max. distance of the rear groove from the shaft end when the installation tool supplied with the sleeve is used

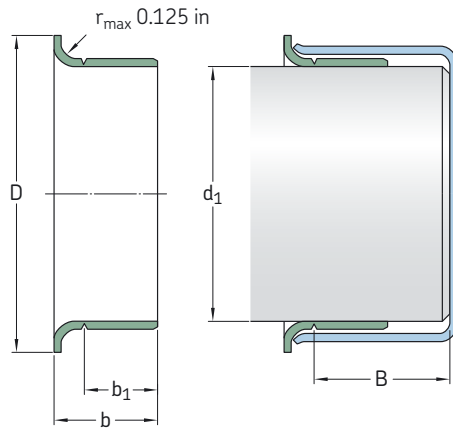

Shaft diameter range		Nominal dimensions					Designation
d_1 min	max	d_1	D $\pm 0,063$	b_1 $\pm 0,031$	b $\pm 0,031$	$B^{1)}$	
in		in					–
0.982	0.986	0.984 0.984	1.300 1.300	0.313 0.313	0.433 0.433	2.000 2.000	CR 99813 * CR 99098
0.998	1.002	1.000 1.000	1.219 1.219	0.313 0.313	0.438 0.438	2.000 2.000	CR 99814 * CR 99100
1.019	1.024	1.024	1.313	0.315	0.472	1.813	CR 99103
1.060	1.064	1.063 1.063	1.320 1.320	0.313 0.313	0.438 0.438	1.843 1.843	CR 99815 * CR 99106
1.087	1.091	1.089	1.406	0.313	0.438	0.625	CR 99108
1.100	1.104	1.102 1.102	1.375 1.375	0.375 0.375	0.500 0.500	1.843 1.843	CR 99866 ** CR 99111
1.123	1.127	1.125 1.125 1.125	1.500 1.500 1.500	0.313 0.313 0.375	0.438 0.438 0.500	0.688 0.688 0.688	CR 99816 * CR 99112 CR 99116
1.154	1.158	1.156 1.156	1.350 1.350	0.375 0.375	0.500 0.500	0.688 0.688	CR 99865 ** CR 99120
1.173	1.178	1.175	1.400	0.313	0.438	0.688	CR 99122
1.179	1.184	1.181	1.400	0.315	0.433	0.688	CR 99114
1.185	1.190	1.188	1.400	0.313	0.438	0.688	CR 99118
1.216	1.222	1.219	1.563	0.313	0.433	0.625	CR 99123
1.237	1.243	1.240	1.540	0.315	0.438	0.688	CR 99141
1.247	1.253	1.250 1.250	1.500 1.500	0.313 0.313	0.438 0.438	0.688 0.688	CR 99817 * CR 99125
1.257	1.263	1.260	1.500	0.315	0.438	0.688	CR 99128
1.297	1.301	1.299	1.594	0.591	0.709	1.000	CR 99121
1.308	1.314	1.313	1.600	0.250	0.375	0.813	CR 99129
1.310	1.316	1.313 1.313	1.594 1.594	0.500 0.500	0.625 0.625	0.813 0.813	CR 99818 ** CR 99131
1.333	1.339	1.339	1.625	0.500	0.625	0.813	CR 99134

* Indicates SKF SPEEDI-SLEEVE Gold

** Indicates SKF SPEEDI-SLEEVE Gold – contact SKF for availability

¹⁾ Possible max. distance of the rear groove from the shaft end when the installation tool supplied with the sleeve is used

SKF SPEEDI-SLEEVE – inch dimensions

d_1 1.371 – 1.971 in

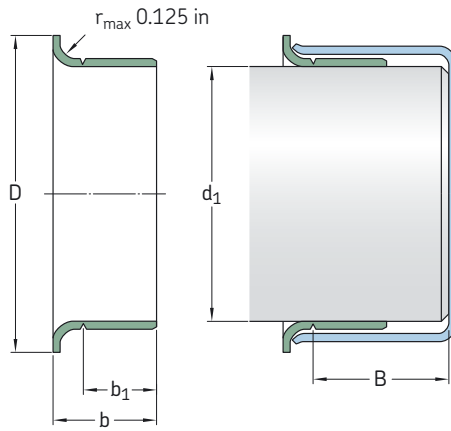

Shaft diameter range		Nominal dimensions					Designation
d_1 min	max	d_1	D $\pm 0,063$	b_1 $\pm 0,031$	b $\pm 0,031$	$B^{1)}$	
in		in					–
1.371	1.377	1.375	1.638	0.313	0.438	0.813	CR 99133
		1.375	1.638	0.500	0.625	0.813	CR 99819 *
		1.375	1.638	0.500	0.625	0.813	CR 99138
1.375	1.381	1.375	1.638	0.512	0.630	0.813	CR 99820 *
		1.375	1.638	0.512	0.630	0.813	CR 99139
1.411	1.417	1.417	1.781	0.512	0.669	0.984	CR 99146
1.432	1.438	1.438	1.781	0.563	0.688	1.016	CR 99821 *
		1.438	1.781	0.563	0.688	1.016	CR 99143
1.435	1.441	1.438	1.781	0.375	0.500	1.016	CR 99144
1.490	1.496	1.496	1.781	0.512	0.669	0.984	CR 99147
1.497	1.503	1.500	1.781	0.375	0.500	1.016	CR 99823 *
		1.500	1.781	0.375	0.500	1.016	CR 99150
		1.500	1.781	0.563	0.688	1.016	CR 99822 *
		1.500	1.781	0.563	0.688	1.016	CR 99149
1.520	1.526	1.523	1.859	0.438	0.563	1.016	CR 99152
1.549	1.555	1.552	1.859	0.438	0.563	1.016	CR 99155
1.559	1.565	1.562	1.859	0.563	0.688	1.016	CR 99824 *
		1.562	1.859	0.563	0.688	1.016	CR 99156
1.566	1.572	1.569	1.859	0.625	0.750	1.016	CR 99159
1.569	1.575	1.575	1.850	0.390	0.509	1.000	CR 99153
1.572	1.578	1.578	1.850	0.512	0.630	1.023	CR 99825 *
		1.578	1.850	0.512	0.630	1.023	CR 99157
1.602	1.608	1.605	1.938	0.500	0.641	1.000	CR 99160
1.608	1.614	1.614	1.938	0.500	0.625	1.016	CR 99163
1.622	1.628	1.625	1.875	0.313	0.438	1.016	CR 99161
		1.625	1.875	0.563	0.688	0.813	CR 99826 *
		1.625	1.875	0.563	0.688	0.813	CR 99162
1.647	1.654	1.650	2.087	0.445	0.571	0.846	CR 99166
		1.650	2.087	0.563	0.689	0.827	CR 99169
		1.654	2.087	0.563	0.689	0.827	CR 99873 **
1.653	1.659	1.656	2.087	0.550	0.689	0.827	CR 99165

* Indicates SKF SPEEDI-SLEEVE Gold

** Indicates SKF SPEEDI-SLEEVE Gold – contact SKF for availability

¹⁾ Possible max. distance of the rear groove from the shaft end when the installation tool supplied with the sleeve is used

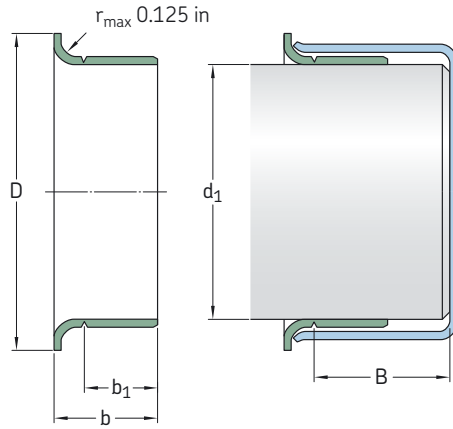

Shaft diameter range		Nominal dimensions					Designation
d_1 min	max	d_1	D $\pm 0,063$	b_1 $\pm 0,031$	b $\pm 0,031$	$B^{1)}$	
in		in					–
1.684	1.690	1.688	1.906	0.563	0.688	0.875	CR 99168
1.685	1.691	1.688	1.906	0.313	0.438	0.875	CR 99167
1.687	1.693	1.693	1.906	0.500	0.625	0.844	CR 99182
1.715	1.721	1.719	2.031	0.563	0.688	0.813	CR 99171
1.736	1.742	1.739	2.063	0.375	0.500	0.813	CR 99170
1.747	1.753	1.750	2.055	0.375	0.500	0.813	CR 99172
		1.750	2.063	0.531	0.625	0.878	CR 99180
		1.750	2.063	0.563	0.688	0.813	CR 99827 *
		1.750	2.063	0.563	0.688	0.813	CR 99174
		1.750	2.063	0.750	0.875	0.813	CR 99828 *
		1.750	2.063	0.750	0.875	0.813	CR 99175
1.761	1.767	1.766	2.063	0.563	0.688	0.813	CR 99829 *
		1.766	2.063	0.563	0.688	0.813	CR 99176
1.769	1.775	1.772	2.087	0.551	0.669	0.812	CR 99830 *
		1.772	2.087	0.551	0.669	0.812	CR 99177
1.778	1.784	1.781	2.125	0.667	0.800	1.062	CR 99179
1.809	1.815	1.813	2.090	0.563	0.688	1.000	CR 99831 **
		1.813	2.090	0.563	0.688	1.000	CR 99181
1.857	1.863	1.859	2.156	0.563	0.688	1.000	CR 99185
1.866	1.872	1.868	2.188	0.889	1.025	1.000	CR 99186
1.872	1.878	1.875	2.203	0.175	0.295	0.744	CR 99190
		1.875	2.203	0.295	0.415	0.744	CR 99188
		1.875	2.203	0.375	0.516	1.050	CR 99184
		1.875	2.203	0.563	0.688	1.000	CR 99832 *
		1.875	2.203	0.563	0.688	1.000	CR 99187
1.887	1.893	1.891	2.205	0.551	0.668	0.984	CR 99189
1.909	1.915	1.912	2.219	0.375	0.500	1.000	CR 99192
1.934	1.940	1.938	2.219	0.563	0.688	1.000	CR 99833 *
		1.938	2.219	0.563	0.688	1.000	CR 99193
1.965	1.971	1.969	2.244	0.551	0.668	0.984	CR 99196

* Indicates SKF SPEEDI-SLEEVE Gold

** Indicates SKF SPEEDI-SLEEVE Gold – contact SKF for availability

¹⁾ Possible max. distance of the rear groove from the shaft end when the installation tool supplied with the sleeve is used

SKF SPEEDI-SLEEVE – inch dimensions

d₁ 1.997 – 2.753 in

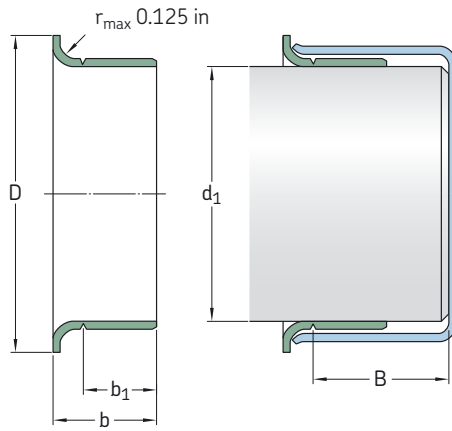

Shaft diameter range		Nominal dimensions					Designation	
d ₁ min	max	d ₁	D ±0,063	b ₁ ±0,031	b ±0,031	B ¹⁾		
in		in						–
1.977	1.983 2.003	1.980	2.313	0.563	0.704	1.050	CR 99198	
		2.000	2.406	0.563	0.688	1.006	CR 99834 *	
		2.000	2.406	0.563	0.688	1.000	CR 99199	
		2.000	2.406	0.875	1.000	1.000	CR 99835 *	
		2.000	2.406	0.875	1.000	1.000	CR 99200	
2.040	2.047	2.047	2.469	0.500	0.625	1.359	CR 99204	
2.057	2.063	2.063	2.469	0.781	0.938	1.375	CR 99205	
2.123	2.128	2.125	2.422	0.500	0.750	1.281	CR 99210	
2.124	2.130	2.125	2.422	0.781	0.938	1.375	CR 99836 *	
		2.125	2.422	0.781	0.938	1.375	CR 99212	
2.162	2.168	2.165	2.441	0.787	0.905	1.250	CR 99863 *	
		2.165	2.441	0.787	0.905	1.250	CR 99215	
2.186	2.192	2.188	2.500	0.781	0.938	1.313	CR 99218	
2.198	2.205	2.205	2.531	0.500	0.625	1.313	CR 99220	
		2.205	2.531	0.779	0.936	3.150	CR 99224	
2.227	2.233	2.230	2.531	0.500	0.625	1.313	CR 99861 **	
		2.230	2.531	0.500	0.625	1.313	CR 99229	
		2.230	2.531	0.781	0.906	1.250	CR 99230	
2.237	2.243	2.240	2.563	0.764	0.900	1.250	CR 99226	
2.249	2.255	2.250	2.531	0.313	0.438	1.313	CR 99838 **	
		2.250	2.531	0.313	0.438	1.313	CR 99227	
		2.250	2.531	0.781	0.938	1.313	CR 99837 *	
		2.250	2.531	0.781	0.938	1.313	CR 99225	
2.280	2.286	2.283	2.598	0.787	0.938	1.375	CR 99219	
2.309	2.315	2.313	2.688	0.781	0.938	1.375	CR 99231	
2.327	2.333	2.328	2.750	0.750	0.875	1.500	CR 99233	
2.359	2.365	2.362	2.785	0.370	0.450	1.471	CR 99241	
		2.362	2.785	0.787	0.905	1.375	CR 99869 **	
		2.362	2.785	0.787	0.905	1.375	CR 99235	
2.372	2.378	2.375	2.750	0.594	0.750	1.375	CR 99238	

* Indicates SKF SPEEDI-SLEEVE Gold

** Indicates SKF SPEEDI-SLEEVE Gold – contact SKF for availability

¹⁾ Possible max. distance of the rear groove from the shaft end when the installation tool supplied with the sleeve is used

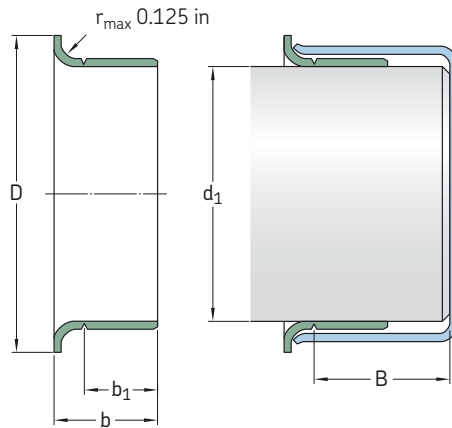

Shaft diameter range		Nominal dimensions					Designation
d_1 min	max	d_1	D $\pm 0,063$	b_1 $\pm 0,031$	b $\pm 0,031$	$B^{1)}$	
in		in					–
2.374	2.380	2.375	2.750	0.526	0.683	1.375	CR 99240
		2.375	2.750	0.781	0.938	1.375	CR 99839 *
		2.375	2.750	0.781	0.938	1.375	CR 99237
2.434	2.440 2.441	2.438	2.828	0.781	0.938	1.393	CR 99243
		2.441	2.828	0.500	0.625	1.425	CR 99244
2.435	2.441	2.438	2.828	0.500	0.625	1.425	CR 99242
2.489	2.495	2.492	2.875	0.781	0.938	1.393	CR 99249
2.497	2.503	2.500	2.820	0.555	0.650	0.890	CR 99253
2.500	2.506	2.500	2.828	0.500	0.656	1.393	CR 99248
		2.500	2.820	0.781	0.938	1.375	CR 99840 *
		2.500	2.820	0.781	0.938	1.375	CR 99250
2.510	2.516	2.516	2.828	0.781	0.906	1.438	CR 99251
2.556	2.562	2.559	2.850	0.787	0.905	1.375	CR 99841 *
		2.559	2.850	0.787	0.905	1.375	CR 99254
2.560	2.566	2.563	2.891	0.781	0.938	1.375	CR 99256
2.595	2.601	2.598	2.990	0.781	0.938	1.250	CR 99259
2.618	2.624	2.621	3.047	0.781	0.938	1.375	CR 99261
2.621	2.627	2.625	3.047	0.781	0.906	1.375	CR 99264
2.622	2.628	2.625	3.047	0.500	0.625	1.375	CR 99260
		2.625	3.047	0.781	0.938	1.375	CR 99842 *
2.625	2.631	2.625	3.047	0.781	0.938	1.375	CR 99262
2.670	2.677	2.677	3.125	0.750	0.875	1.688	CR 99266
2.727	2.733	2.730	3.125	0.781	0.906	1.313	CR 99268
2.740	2.746	2.743	3.065	0.781	0.938	1.250	CR 99273
2.745	2.751	2.750	3.125	0.781	0.938	1.250	CR 99843 *
		2.750	3.125	0.781	0.938	1.250	CR 99274
2.747	2.753	2.750	3.075	1.438	1.625	1.625	CR 99267

* Indicates SKF SPEEDI-SLEEVE Gold

¹⁾ Possible max. distance of the rear groove from the shaft end when the installation tool supplied with the sleeve is used

SKF SPEEDI-SLEEVE – inch dimensions

d₁ 2.750 – 3.624 in

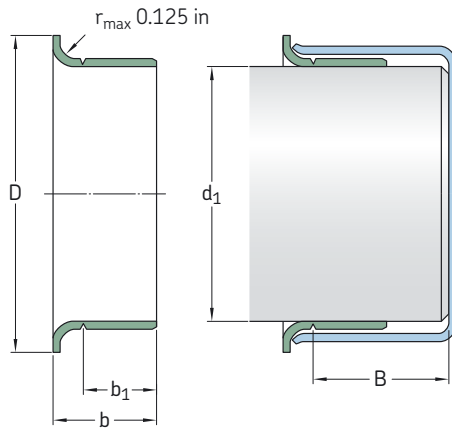

Shaft diameter range		Nominal dimensions					Designation	
d ₁ min	max	d ₁	D ±0,063	b ₁ ±0,031	b ±0,031	B ¹⁾		
in		in						–
2.750	2.756	2.750	3.125	0.406	0.563	1.250	CR 99272	
		2.750	3.125	0.781	0.938	1.250	CR 99844 *	
		2.750	3.125	0.781	0.938	1.250	CR 99275	
		2.750	3.125	1.125	1.250	1.312	CR 99269	
2.753	2.759	2.756	3.125	0.787	0.945	1.250	CR 99276	
2.809	2.815	2.813	3.188	0.594	0.688	1.250	CR 99281	
2.828	2.835	2.835	3.225	0.750	0.875	1.343	CR 99870 **	
		2.835	3.225	0.750	0.875	1.343	CR 99284	
2.838	2.844	2.838	3.225	0.500	0.656	1.250	CR 99845 *	
		2.838	3.225	0.500	0.656	1.250	CR 99282	
2.866	2.872	2.869	3.188	0.781	0.938	1.250	CR 99286	
2.873	2.879	2.875	3.219	0.781	0.938	1.250	CR 99846 *	
		2.875	3.219	0.781	0.938	1.250	CR 99287	
2.937	2.943	2.938	3.344	0.500	0.641	1.331	CR 99290	
		2.938	3.344	0.781	0.938	1.313	CR 99847 *	
		2.940	3.344	0.781	0.938	1.313	CR 99293	
2.950	2.956	2.953	3.273	0.594	0.690	1.083	CR 99289	
		2.953	3.305	0.866	1.024	1.313	CR 99875 **	
		2.953	3.305	0.866	1.024	1.313	CR 99294	
2.972	2.976	2.974	3.235	0.813	1.000	1.250	CR 99292	
2.990	2.996	2.993	3.359	0.484	0.625	1.331	CR 99291	
		2.993	3.359	0.563	0.688	1.375	CR 99298	
		2.993	3.350	0.813	1.000	1.281	CR 99299	
2.997	3.003	3.000	3.240	0.813	0.938	1.375	CR 99296	
3.000	3.006	3.000	3.345	0.625	0.813	1.280	CR 99303	
		3.000	3.235	0.813	1.000	1.281	CR 99848 *	
		3.000	3.235	0.813	1.000	1.281	CR 99300	
3.008	3.014	3.011	3.355	0.500	0.625	2.000	CR 99301	
3.064	3.071	3.071	3.468	0.750	0.875	2.056	CR 99306	
3.120	3.126	3.125	3.531	0.688	0.813	2.000	CR 99311	
		3.125	3.531	0.813	1.000	2.000	CR 99849 *	
		3.125	3.531	0.813	1.000	2.000	CR 99312	

* Indicates SKF SPEEDI-SLEEVE Gold

** Indicates SKF SPEEDI-SLEEVE Gold – contact SKF for availability

¹⁾ Possible max. distance of the rear groove from the shaft end when the installation tool supplied with the sleeve is used

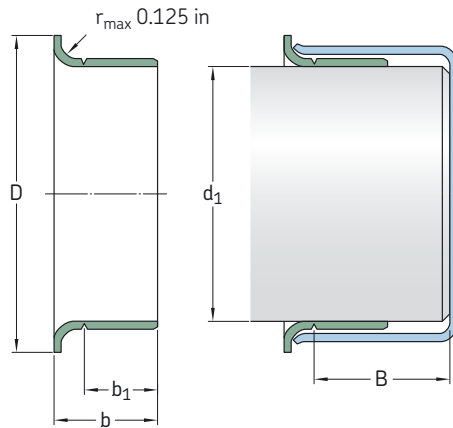

Shaft diameter range		Nominal dimensions					Designation
d_1 min	max	d_1	D $\pm 0,063$	b_1 $\pm 0,031$	b $\pm 0,031$	$B^{1)}$	
in		in					–
3.124	3.132	3.125	3.525	0.551	0.709	2.031	CR 99307
3.142	3.150	3.150	3.540	0.750	0.886	1.375	CR 99313
3.146	3.153	3.150	3.543	0.433	0.591	1.375	CR 99317
		3.150	3.543	0.827	0.945	1.375	CR 99315
3.225	3.231	3.228	3.585	0.660	0.848	1.750	CR 99328
3.247	3.253	3.250	3.594	0.813	1.000	1.375	CR 99322
3.250	3.256	3.250	3.575	0.595	0.719	1.375	CR 99850 *
		3.250	3.575	0.595	0.719	1.375	CR 99324 *
		3.250	3.585	0.688	0.875	1.250	CR 99326
		3.250	3.585	0.813	1.000	1.375	CR 99851 *
		3.250	3.585	0.813	1.000	1.375	CR 99325
3.307	3.313	3.310	3.688	0.813	1.000	1.375	CR 99331
3.337	3.347	3.342	3.700	0.669	0.827	1.378	CR 99332
		3.342	3.700	0.827	0.984	1.378	CR 99333
		3.346	3.700	0.827	0.984	1.378	CR 99872 *
3.338	3.346	3.346	3.580	0.399	0.499	1.431	CR 99334
3.373	3.379	3.375	3.688	0.375	0.500	1.410	CR 99338
		3.375	3.695	0.813	1.000	1.375	CR 99337
3.435	3.441	3.438	3.844	0.781	0.906	1.406	CR 99339
3.477	3.483	3.480	3.835	0.781	0.906	1.406	CR 99340
3.497	3.503	3.500	3.844	0.625	0.813	1.347	CR 99346
3.500	3.506	3.500	3.825	0.313	0.500	1.347	CR 99347
		3.500	3.844	0.813	1.000	1.347	CR 99852 *
		3.500	3.844	0.813	1.000	1.347	CR 99350
3.501	3.507	3.504	3.844	0.625	0.813	1.348	CR 99349
3.540	3.546	3.543	4.000	0.438	0.538	1.813	CR 99352
		3.543	4.000	0.526	0.667	1.750	CR 99353
		3.543	4.000	0.710	0.906	1.813	CR 99351
		3.543	4.000	0.906	1.102	1.750	CR 99354
3.560	3.566	3.563	3.900	0.813	1.000	1.750	CR 99356
3.618	3.624	3.621	4.031	0.813	1.000	1.750	CR 99360

* Indicates SKF SPEEDI-SLEEVE Gold

¹⁾ Possible max. distance of the rear groove from the shaft end when the installation tool supplied with the sleeve is used

SKF SPEEDI-SLEEVE – inch dimensions

d_1 3.623 – 5.379 in

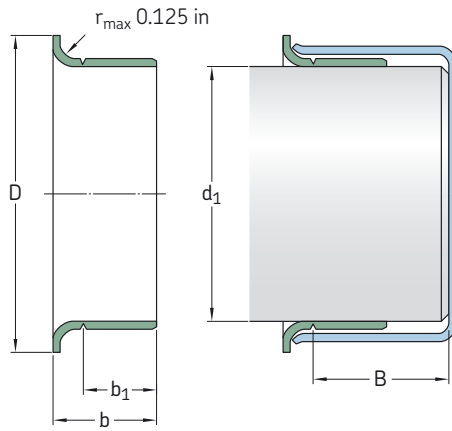

Shaft diameter range		Nominal dimensions					Designation
d_1 min	max	d_1	D $\pm 0,063$	b_1 $\pm 0,031$	b $\pm 0,031$	$B^{1)}$	
in		in					–
3.623	3.629	3.625	4.025	0.500	0.625	1.750	CR 99363
		3.625	4.031	0.813	1.000	1.750	CR 99362
3.684	3.690	3.688	4.031	0.313	0.438	0.875	CR 99368
3.685	3.691	3.688	4.025	0.813	0.938	1.800	CR 99365
3.727	3.733	3.730	4.016	0.469	0.594	1.800	CR 99359
		3.730	4.025	0.781	0.906	1.800	CR 99366
3.737	3.743	3.740	4.025	0.827	0.945	1.800	CR 99369
3.740	3.746	3.743	4.031	0.344	0.500	1.800	CR 99374
		3.743	4.035	0.469	0.594	1.800	CR 99364
3.746	3.752	3.749	4.025	0.563	0.688	1.800	CR 99376
3.750	3.756	3.753	4.025	0.344	0.500	1.800	CR 99367
		3.750	4.020	0.688	0.875	1.800	CR 99853 *
		3.753	4.020	0.688	0.875	1.800	CR 99372
3.868	3.874	3.871	4.185	0.813	1.000	1.875	CR 99386
3.873	3.879	3.875	4.219	0.813	1.000	1.875	CR 99387
3.935	3.941	3.938	4.313	0.813	1.000	2.050	CR 99854 *
		3.938	4.313	0.813	1.000	2.050	CR 99393
3.998	4.006	4.000	4.375	0.500	0.625	2.066	CR 99401
		4.000	4.375	0.600	0.725	2.050	CR 99395
		4.000	4.375	0.650	0.775	1.375	CR 99400
		4.000	4.375	0.813	1.000	2.050	CR 99855 *
		4.000	4.375	0.813	1.000	2.050	CR 99399
4.090	4.098	4.094	4.438	0.787	0.945	1.417	CR 99409
4.122	4.130	4.125	4.470	0.813	1.000	1.375	CR 99412
4.130	4.138	4.134	4.470	0.787	0.913	1.378	CR 99413
4.183	4.191	4.188	4.500	0.813	1.000	1.375	CR 99418
4.226	4.234	4.234	4.610	0.781	0.906	1.438	CR 99423
4.248	4.256	4.250	4.610	0.813	1.000	1.438	CR 99424
4.322	4.331	4.331	4.921	0.448	0.589	1.297	CR 99434
4.327	4.335	4.328	4.921	0.509	0.650	1.250	CR 99435

* Indicates SKF SPEEDI-SLEEVE Gold

¹⁾ Possible max. distance of the rear groove from the shaft end when the installation tool supplied with the sleeve is used

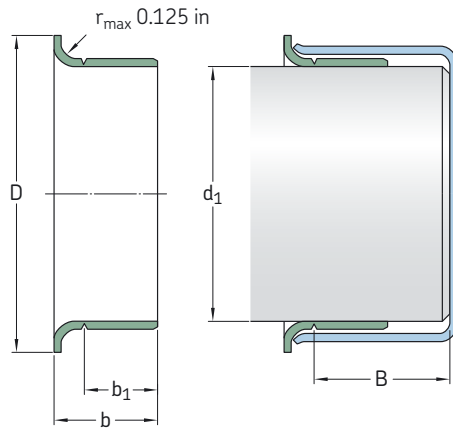

Shaft diameter range		Nominal dimensions					Designation
----------------------	--	--------------------	--	--	--	--	-------------

d_1 min	max	d_1	D $\pm 0,063$	b_1 $\pm 0,031$	b $\pm 0,031$	$B^{1)}$	
in		in					–
4.370	4.378	4.375	4.750	0.813	1.000	1.650	CR 99437
4.401	4.409	4.409	4.750	0.750	0.886	1.300	CR 99438
4.434	4.442	4.438	4.813	1.000	1.142	1.313	CR 99439
4.496	4.504	4.500	4.850	0.813	1.000	1.250	CR 99450
		4.500	4.900	0.813	1.000	1.250	CR 99856 *
4.523	4.531	4.528	5.000	0.813	0.938	1.250	CR 99452
4.621	4.629	4.625	5.000	0.438	0.625	1.375	CR 99465
		4.625	5.063	1.000	1.250	1.375	CR 99463
4.685	4.693	4.688	5.063	0.813	1.000	1.375	CR 99468
4.720	4.728	4.724	5.110	0.315	0.433	1.323	CR 99471
		4.724	5.110	0.787	0.984	1.260	CR 99473
4.746	4.754	4.750	5.000	0.500	0.750	1.500	CR 99475
4.799	4.807	4.803	5.177	0.787	0.945	1.260	CR 99472
4.839	4.847	4.843	5.229	0.787	0.984	1.244	CR 99484
4.871	4.879	4.875	5.250	0.625	0.750	1.438	CR 99487
4.917	4.925	4.921	5.400	0.394	0.551	1.438	CR 99490
		4.921	5.400	1.024	1.260	1.438	CR 99492
4.998	5.006	5.000	5.400	0.540	0.681	1.438	CR 99501
		5.000	5.400	0.688	0.875	1.438	CR 99857 *
		5.000	5.400	0.688	0.875	1.438	CR 99498
		5.000	5.390	0.813	1.000	1.438	CR 99858 *
		5.000	5.390	0.813	1.000	1.438	CR 99499
5.110	5.118	5.114	5.493	0.750	0.938	1.181	CR 99494
5.117	5.125	5.118	5.493	0.866	0.996	1.280	CR 99874 **
		5.125	5.493	0.866	0.996	1.280	CR 99491
5.120	5.128	5.125	5.500	0.813	1.000	1.250	CR 99513
5.246	5.254	5.250	5.560	0.813	1.000	1.250	CR 99525
5.307	5.315	5.311	5.735	0.807	1.000	1.250	CR 99533
5.371	5.379	5.375	5.875	0.813	1.000	1.250	CR 99537

* Indicates SKF SPEEDI-SLEEVE Gold

** Indicates SKF SPEEDI-SLEEVE Gold – contact SKF for availability

¹⁾ Possible max. distance of the rear groove from the shaft end when the installation tool supplied with the sleeve is used

SKF SPEEDI-SLEEVE – inch dimensions

d₁ 5.434 – 8.005 in

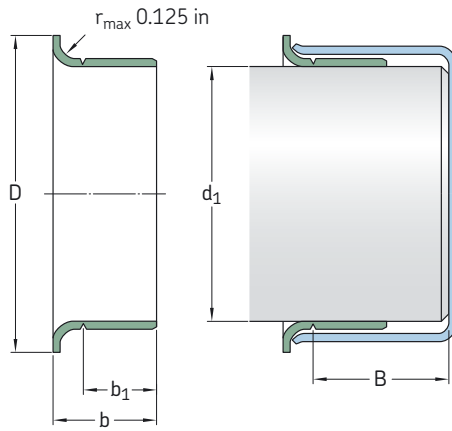

Shaft diameter range		Nominal dimensions					Designation
d ₁ min	max	d ₁	D ±0,063	b ₁ ±0,031	b ±0,031	B ¹⁾	
in		in					–
5.434	5.442	5.438	5.750	1.500	1.688	1.875	CR 99548
5.472	5.480	5.476	5.900	0.563	0.750	1.234	CR 99547
5.498	5.506	5.500	5.938	0.518	0.705	1.250	CR 99550
		5.500	5.938	0.813	1.000	1.250	CR 99859 **
		5.500	5.938	0.813	1.000	1.250	CR 99549
5.508	5.516	5.512	5.945	0.807	1.000	1.250	CR 99552
5.621	5.629	5.625	6.188	0.875	1.000	1.812	CR 99560
5.699	5.709	5.709	6.100	0.750	0.875	1.812	CR 99571
5.726	5.734	5.734	6.100	0.563	0.750	1.938	CR 99562
5.746	5.754	5.750	6.180	0.813	1.000	1.750	CR 99575
5.871	5.879	5.875	6.188	1.000	1.250	1.313	CR 99862 *
		5.875	6.188	1.000	1.250	1.313	CR 99587
5.896	5.906	5.905	6.260	1.024	1.181	1.280	CR 99595
5.934	5.942	5.938	6.375	1.000	1.125	1.875	CR 99596
5.995	6.003	6.000	6.360	0.500	0.750	1.750	CR 99601
		6.000	6.375	1.000	1.250	1.750	CR 99599
6.058	6.068	6.063	6.375	1.024	1.181	1.299	CR 99605
6.092	6.102	6.097	6.575	1.024	1.181	1.299	CR 99606
6.198	6.208	6.203	6.625	0.813	1.063	1.750	CR 99620
6.245	6.255	6.250	6.625	1.031	1.250	1.750	CR 99625
6.289	6.299	6.299	6.750	1.000	1.250	1.375	CR 99630
6.495	6.505	6.500	7.000	1.000	1.250	1.375	CR 99650
6.683	6.693	6.688	7.188	1.250	1.496	1.750	CR 99640
6.745	6.755	6.750	7.125	0.813	1.063	1.750	CR 99675
6.880	6.890	6.890	7.362	1.102	1.260	1.378	CR 99687

* Indicates SKF SPEEDI-SLEEVE Gold

** Indicates SKF SPEEDI-SLEEVE Gold – contact SKF for availability

¹⁾ Possible max. distance of the rear groove from the shaft end when the installation tool supplied with the sleeve is used

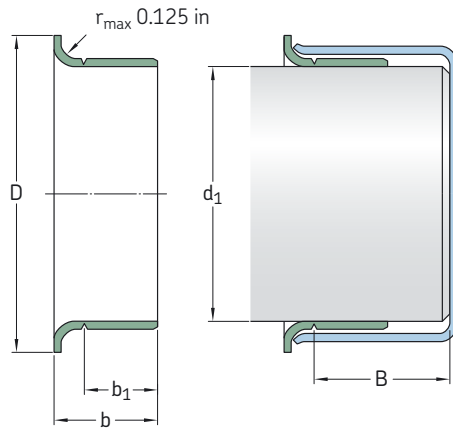

Shaft diameter range		Nominal dimensions					Designation
d_1 min	max	d_1	D $\pm 0,063$	b_1 $\pm 0,031$	b $\pm 0,031$	$B^{1)}$	
in		in					–
6.995	7.005	7.000 7.000	7.475 7.475	1.000 1.000	1.250 1.250	1.688 1.688	CR 99864 ** CR 99700
7.077	7.087	7.087	7.500	1.299	1.496	1.752	CR 99721
7.244	7.254	7.250	7.760	1.250	1.500	2.175	CR 99725
7.273	7.283	7.278	7.760	1.260	1.496	2.165	CR 99726
7.444	7.454	7.453	7.860	0.813	1.000	1.250	CR 99745
7.495	7.505	7.500	7.875	0.813	1.000	1.250	CR 99750
7.745	7.755	7.750	8.270	1.000	1.313	1.875	CR 99775
7.869	7.879	7.875	8.375	1.359	1.500	1.750	CR 99787
7.933	7.943	7.938	8.375	1.000	1.250	1.750	CR 99799
7.995	8.005	8.000	8.375	1.000	1.250	1.750	CR 99800

** Indicates SKF SPEEDI-SLEEVE Gold – contact SKF for availability

¹⁾ Possible max. distance of the rear groove from the shaft end when the installation tool supplied with the sleeve is used

Large diameter wear sleeves

Outside contamination particles and polishing friction between a rotating shaft and a seal, over time, can result in severe shaft damage. Instead of repairing or replacing the damaged shaft, SKF recommends the use of large diameter wear sleeves (LDSL) primarily in applications where no SKF SPEEDI-SLEEVE is available, i.e. for shaft sizes in the diameter range 211,15 to 1 143 mm (8.313 to 45 in). SKF LDSLV are made to order to fit shaft sizes within the primary ranges stated in **tables 1** and **2**. A selection of possible sizes is listed in the product tables starting on **page 34**.

The use of LDSLV is recommended in applications where the operating conditions for the seals are difficult, particularly where solid contaminants can reach the seals, e.g. in rolling mills, primary metal plants and in chemical and mineral plants.

In applications where seal wear and shaft damage can be expected, it is recommended that the large diameter wear sleeves are installed into the application already from the outset. It will then not be necessary to rework the shaft before installing a replacement sleeve and the original seal size can be used as the replacement.

Table 1

Primary dimension range of LDSLV3

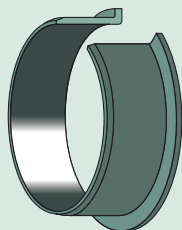

Shaft range		Width ¹⁾	
over	incl.	min	max
mm/in		mm/in	
211,15 8.313	736,60 29.000	17,48 0.688	63,50 2.500
736,60 29.000	1 143 45.000	25,40 1.000	63,50 2.500

¹⁾ Overall, 38,1 to 50,8 mm (1.5 to 2 in) at 1 143 mm (45 in) shaft diameter
Contact SKF for large diameter sleeves outside the primary range

Table 2

Primary dimension range of LDSLV4



Shaft range		Width ¹⁾	
over	incl.	min	max
mm/in		mm/in	
211,15 8.313	736,60 29.000	12,70 0.500	63,50 2.500
736,60 29.000	1 143 45.000	19,05 0.750	63,50 2.500

¹⁾ Overall, 38,1 to 50,8 mm (1.5 to 2 in) at 1 143 mm (45 in) shaft diameter
Contact SKF for large diameter sleeves outside the primary range

Designs and features

There are two designs of SKF large diameter wear sleeves; type LDSLV3 with a flange (→ **fig. 1**) and type LDSLV4 without a flange (→ **fig. 2**). Both types are made of high quality SAE 1008 carbon steel and chrome plated to enhance wear and corrosion resistance. The sleeve outside diameter is specially ground to provide a precision counter surface for the seal. The wall thickness of the standard sleeves is 2,39 mm (0.094 in). Other sleeve materials can be provided to meet the demands of a specific application.

Type LDSLV3 is designed with a flange to simplify final positioning of the sleeve. The width of the counterface for the seal is 6,35 mm (0.250 in) narrower than the total width of the sleeve. The flange adds a nominal 25,4 mm (1.000 in) over the shaft diameter. The flange height is 12,7 mm (0.500 in) for all sizes. Note that force should never be applied directly to the flange when installing type LDSLV3.

Type LDSLV4 has the same features as type LDSLV3 but without a flange. LDSLV4 is intended for applications where a flange could interfere with other components during installation, or where a wider contact surface for the seal is required.

Using LDSLV designs

There are two alternative ways of using SKF large diameter wear sleeves (→ **fig. 3**);

1. The sleeve is positioned on the shaft until it covers the damaged part and a new seal, designed for a 4,78 mm (0.188 in) larger shaft diameter is used.
2. The shaft is machined down 4,78 mm (0.188 in) in diameter, the sleeve is installed and the original seal size is used.

The reworked shaft surface for the sleeve should have a surface roughness of between R_a 2,5 and 3,2 μm (100 to 125 μin)

IMPORTANT: The shaft tolerances for large diameter wear sleeves, due to their heated slip-fit installation, are different from those for radial shaft seals. Contact SKF for assistance if the sleeves are to be used in systems with sustained temperatures higher than 75 °C (170 °F) and surface speeds in excess of 20 m/s (3 950 ft/min).

Installation

SKF large diameter wear sleeves are designed for a heated slip-fit installation and must therefore be uniformly heated prior to installation on the shaft. The sleeve temperature should be approximately 180 °C (350 °F). Under no circumstances should the sleeve be heated to above 200 °C (400 °F). Any of the heating techniques normally used for bearings is suitable, e.g. induction heaters or heating cabinets.

The sleeves should be installed immediately after heating since they cool rapidly and could seize on the shaft before the correct position is achieved. Repositioning of the sleeves by impacts from hammers, etc. should be avoided or minimized and care taken not to damage the ground outside diameter or lead-in-chamfer.

Removal

To remove large diameter wear sleeves it is recommended first to either heat them or to expand them by light hammer blows. The flange of type LDSLV3 should first be cut through at one point, using care not to damage the shaft surface.

LDSLV3

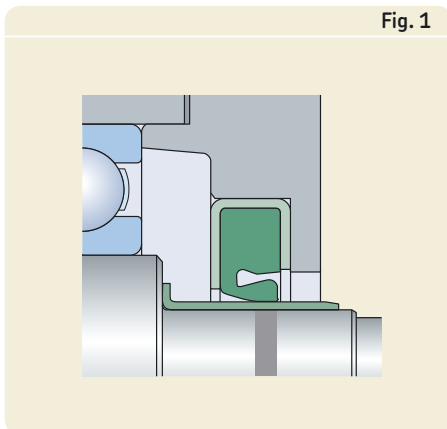

LDSLV4

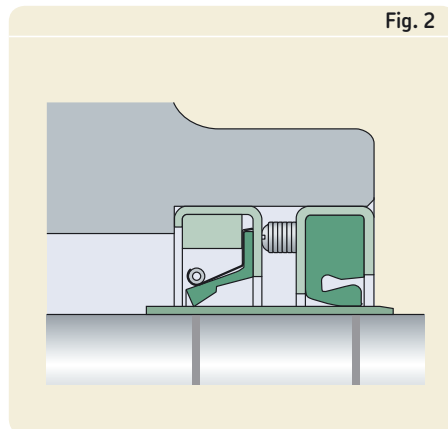

Using LDSLV designs

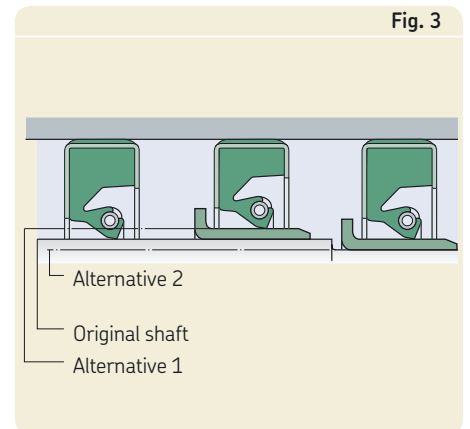

Wear sleeves, series LDSLV – metric dimensions

d₁ 215 – 1 100,23 mm

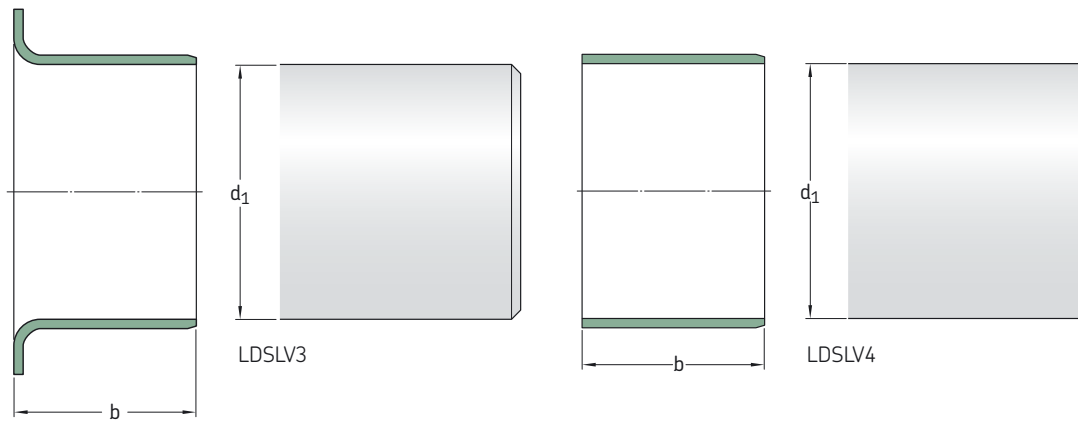

Shaft diameter	Sleeve width	For nominal seal inside diameter	Design	Designation	Shaft diameter	Sleeve width	For nominal seal inside diameter	Design	Designation
d ₁	b				d ₁	b			
mm		mm	–	–	mm		mm	–	–
215	25,4	220	LDSLV3	CR 90179	405,23	50	410	LDSLV4	CR 90042
215,2	35	220	LDSLV3	CR 87831	419,99	63,5	425	LDSLV3	CR 97064
220	25	225	LDSLV3	CR 90806	435,2	63,5	440	LDSLV4	CR 87916
	40	225	LDSLV3	CR 87914					
	50,8	225	LDSLV3	CR 87915					
235,23	18	240	LDSLV4	CR 90952	455	30	460	LDSLV4	CR 90347
240	17,5	250	LDSLV3	CR 90156	455,2	50	460	LDSLV4	CR 87504
245,2	63,5	250	LDSLV3	CR 90766	494,44	24	500	LDSLV4	CR 90259
280	45	285	LDSLV4	CR 90437	503,25	24	508	LDSLV4	CR 90149
295,2	32	300	LDSLV3	CR 90114	535,23	63	540	LDSLV4	CR 90802
320	63,5	325	LDSLV4	CR 90198	575,23	63,5	580	LDSLV4	CR 90951
335,22	39	340	LDSLV4	CR 90777	595,2	58,17	600	LDSLV3	CR 90120
335,22	18	340	LDSLV4	CR 87901	595,22	50	600	LDSLV3	CR 90241
340	50	345	LDSLV3	CR 90113	645,24	63,5	650	LDSLV3	CR 87817
50	360	LDSLV4	CR 90785	685,22	63,5	960	LDSLV4	CR 90953	
360	44	365	LDSLV4	CR 87500	714,81	50	720	LDSLV4	CR 87820
365,2	20	370	LDSLV4	CR 87531	755,19	63,5	760	LDSLV3	CR 87981

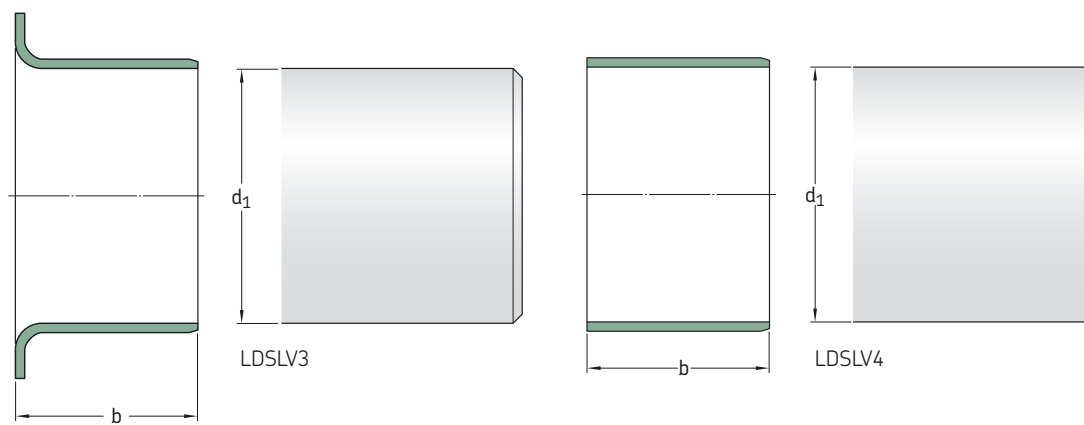

Shaft diameter	Sleeve width	For nominal seal inside diameter	Design	Designation
d_1	b			
mm		mm	–	–
865,23	63,5	870	LDSLV4	CR 90221
875,18	63,5	880	LDSLV4	CR 90103
1 015,20	25	1 020	LDSLV4	CR 90786
1 049,33	60	1 054	LDSLV4	CR 89947
1 100,23	63	1 105	LDSLV4	CR 89946

Wear sleeves, series LDSLV – inch dimensions

d₁ 8.313 – 11.968 in

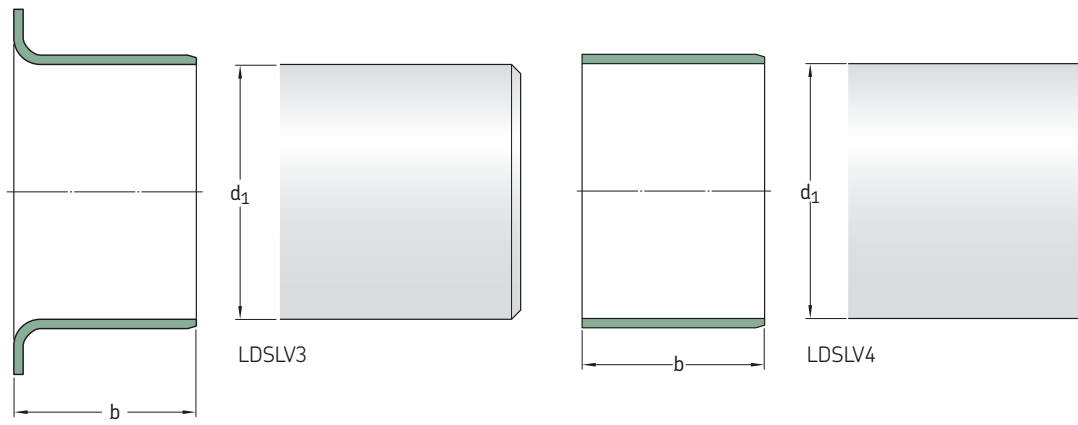

Shaft diameter	Sleeve width	For nominal seal inside diameter	Design	Designation	Shaft diameter	Sleeve width	For nominal seal inside diameter	Design	Designation
d ₁	b				d ₁	b			
in/mm		in/mm	–	–	in/mm		in/mm	–	–
8.313 211,15	1.250 31,75	8.500 215,90	LDSL4	CR 85885	9.125 231,78	1.000 25,40	9.313 236,55	LDSL4	CR 86547
8.353 212,17	1.500 38,10	8.541 216,94	LDSL4	CR 86907		1.500 38,10	9.313 236,55	LDSL4	CR 90130
8.500 215,90	1.000 25,40	8.688 220,68	LDSL3	CR 85158	9.250 234,95	0.875 22,23	9.438 239,73	LDSL4	CR 84643
8.625 219,08	2.750 69,85	8.813 223,85	LDSL3	CR 85643	9.260 235,20	1.102 28,00	9.448 239,98	LDSL4	CR 87789
8.661 220,00	1.000 25,40	8.849 224,76	LDSL4	CR 87319	9.313 236,55	1.500 38,10	9.500 241,30	LDSL3	CR 85377
8.687 220,65	2.250 57,15	8.875 225,43	LDSL3	CR 86543	9.449 240,01	1.181 30,00	9.637 244,78	LDSL4	CR 87144
8.750 222,25	1.500 38,10	8.938 227,03	LDSL3	CR 87196	9.500 241,30	2.500 63,50	9.688 246,08	LDSL4	CR 86562
8.812 223,82	2.000 50,80	9.000 228,60	LDSL4	CR 86551	9.500 241,30	1.000 25,40	9.688 246,08	LDSL3	CR 86633
8.813 223,85	1.000 25,40	9.000 228,60	LDSL3	CR 85688	9.563 242,90	1.000 25,40	9.750 247,65	LDSL4	CR 85073
8.866 225,19	2.500 63,50	9.054 229,97	LDSL4	CR 87166		2.000 50,80	9.750 247,65	LDSL4	CR 85397
8.867 225,22	1.000 25,40	9.055 230,00	LDSL4	CR 87462	9.750 247,65	1.438 36,53	9.938 252,43	LDSL4	CR 84965
8.875 225,43	1.250 31,75	9.063 230,20	LDSL3	CR 85973	9.750 252,43	2.250 57,15	9.938 252,43	LDSL4	CR 85045
8.875 225,43	1.250 31,75	9.063 230,20	LDSL4	CR 87526	9.813 249,24	1.125 28,58	10.000 254,00	LDSL4	CR 86413
8.938 227,03	2.500 63,50	9.126 231,80	LDSL4	CR 86546		2.000 50,80	10.000 254,00	LDSL3	CR 84156
9.000 228,60	1.000 25,40	9.188 233,38	LDSL3	CR 87555	9.835 249,80	1.575 40,00	10.023 254,58	LDSL4	CR 90773
9.055 230,00	1.000 25,40	9.243 234,77	LDSL3	CR 89943	10.000 254,00	1.000 25,40	10.188 258,78	LDSL3	CR 90070
9.063 230,20	1.500 38,10	9.250 234,95	LDSL4	CR 85931	10.063 255,60	2.250 57,15	10.250 260,35	LDSL4	CR 86000
					10.188 258,78	1.125 28,58	10.375 263,53	LDSL4	CR 84962

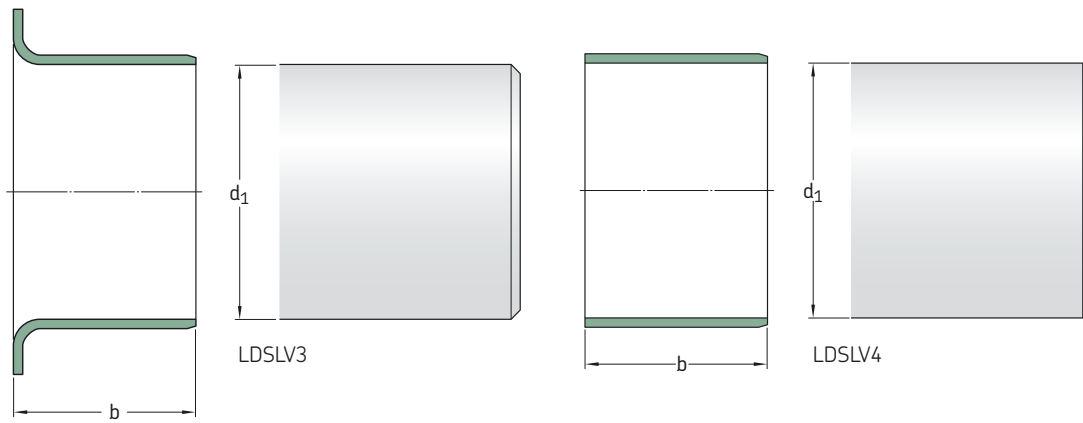

Shaft diameter	Sleeve width	For nominal seal inside diameter	Design	Designation	Shaft diameter	Sleeve width	For nominal seal inside diameter	Design	Designation
d_1	b				d_1	b			
in/mm		in/mm	-	-	in/mm		in/mm	-	-
10.236 260,00	1.968 50,00	10.424 264,77	LDSLV3	CR 87738	11.031 280,20	1.260 32,00	11.219 284,96	LDSLV4	CR 87525
10.313 261,95	2.000 50,80	10.500 266,70	LDSLV4	CR 85629	11.062 280,77	1.750 44,45	11.250 285,75	LDSLV4	CR 85469
	2.250 57,15	10.500 266,70	LDSLV3	CR 85191	11.187 284,15	1.250 31,75	11.375 288,93	LDSLV4	CR 86269
10.441 265,20	2.165 55,00	10.629 269,98	LDSLV4	CR 86798	11.188 284,18	2.250 57,15	11.375 288,93	LDSLV4	CR 85212
10.500 266,70	2.750 69,85	10.688 271,48	LDSLV4	CR 86013	11.190 284,23	2.250 57,15	11.378 289,00	LDSLV4	CR 87566
10.557 268,15	2.250 44,45	10.745 272,92	LDSLV4	CR 85491	11.313 287,34	1.500 38,10	11.500 292,10	LDSLV4	CR 84094
10.562 268,27	0.984 24,99	10.750 273,05	LDSLV4	CR 90800	11.375 288,93	2.250 57,15	11.563 293,70	LDSLV4	CR 86145
	1.750 44,45	10.750 273,05	LDSLV4	CR 86468	11.417 290,00	1.750 44,45	11.605 294,77	LDSLV4	CR 86441
	1.813 46,05	10.750 273,05	LDSLV4	CR 86544	11.500 292,10	0.750 19,05	11.688 296,88	LDSLV4	CR 90761
10.563 268,30	1.500 38,10	10.563 268,30	LDSLV4	CR 87768	11.562 293,68	1.000 25,40	11.562 293,67	LDSLV4	CR 90333
10.750 273,05	2.500 63,50	10.938 277,83	LDSLV4	CR 86435	11.623 295,22	1.417 36,00	11.811 300,00	LDSLV3	CR 87875
10.813 274,64	1.000 25,40	11.000 279,40	LDSLV3	CR 81389	11.750 298,45	2.375 60,33	11.938 303,23	LDSLV3	CR 87872
	2.000 50,80	11.000 279,40	LDSLV4	CR 85033	11.812 300,03	1.125 28,56	12.000 304,80	LDSLV4	CR 86687
10.846 275,50	0.709 18,00	11.034 280,26	LDSLV4	CR 86601	11.813 300,05	1.500 38,10	12.000 304,80	LDSLV4	CR 85979
10.875 276,23	2.000 50,80	11.063 281,00	LDSLV4	CR 84510		2.250 57,15	12.000 304,80	LDSLV3	CR 84819
11.000 279,40	1.500 38,10	11.188 284,18	LDSLV4	CR 86486		2.750 69,85	12.000 304,80	LDSLV4	CR 85844
	2.500 63,50	11.188 284,18	LDSLV4	CR 86454	11.968 304,00	0.709 18,01	12.156 308,76	LDSLV4	CR 86600
11.023 280,00	1.181 30,00	11.212 284,78	LDSLV4	CR 87142					

Wear sleeves, series LDSLV – inch dimensions

d_1 12.000 – 20.813 in

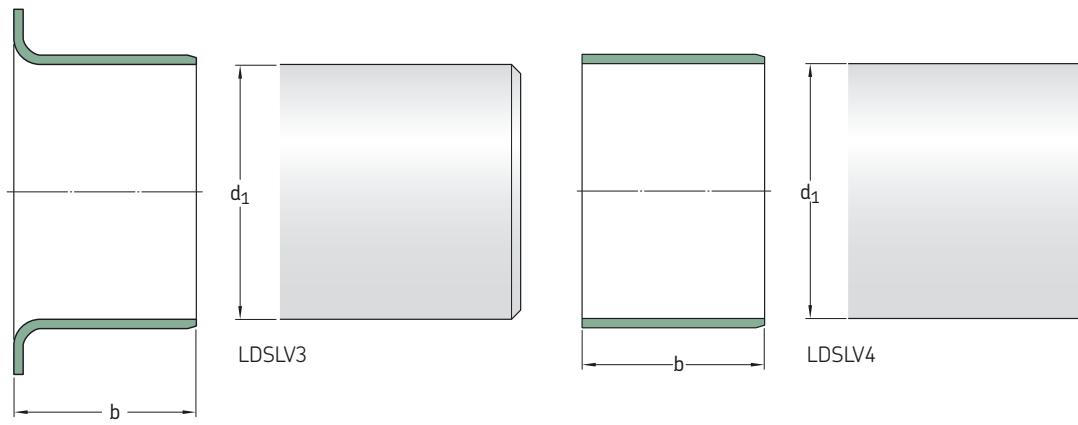

Shaft diameter	Sleeve width	For nominal seal inside diameter	Design	Designation	Shaft diameter	Sleeve width	For nominal seal inside diameter	Design	Designation
d_1	b				d_1	b			
in/mm		in/mm	–	–	in/mm		in/mm	–	–
12.000 304,80	2.250 57,15	12.188 309,58	LDSLV4	CR 85577	13.813 350,84	1.500 38,10	14.000 355,60	LDSLV3	CR 81390
	2.250 57,15	12.188 309,58	LDSLV3	CR 87406		2.000 50,80	14.000 355,60	LDSLV4	CR 85179
12.063 306,40	0.625 15,88	12.250 311,15	LDSLV4	CR 85418	14.000 355,60	1.375 34,93	14.188 360,38	LDSLV3	CR 89951
	2.500 63,50	12.250 311,15	LDSLV3	CR 86404		1.500 38,10	14.188 360,38	LDSLV3	CR 81352
12.312 312,73	1.500 38,10	12.500 317,50	LDSLV4	CR 90174	14.173 359,99	1.000 25,40	14.361 364,77	LDSLV4	CR 87445
12.313 312,74	0.750 19,05	12.500 317,50	LDSLV4	CR 83760	14.313 363,55	1.500 38,10	14.500 368,30	LDSLV4	CR 86429
12.500 317,50	2.125 53,98	12.688 322,28	LDSLV3	CR 86169	14.438 366,73	2.500 63,50	14.625 371,48	LDSLV3	CR 86403
12.598 320,00	0.980 25,00	12.786 324,76	LDSLV3	CR 87434	14.500 368,30	1.000 25,40	14.688 373,08	LDSLV4	CR 85914
12.750 323,85	0.688 17,48	12.938 328,63	LDSLV4	CR 87513	14.813 376,24	1.500 38,10	15.000 381,00	LDSLV4	CR 87723
	1.125 28,58	12.938 328,63	LDSLV3	CR 82099		2.125 54,00	15.000 381,00	LDSLV3	CR 81391
	1.500 38,10	12.938 328,63	LDSLV3	CR 90143	15.000 381,00	1.000 25,40	15.188 385,78	LDSLV4	CR 87247
12.813 325,44	1.000 25,40	13.000 330,20	LDSLV4	CR 86258	15.062 382,58	0.750 19,05	15.250 387,35	LDSLV4	CR 90272
	1.375 34,93	13.000 330,20	LDSLV4	CR 84263		2.000 50,80	15.254 387,45	LDSLV3	CR 87871
	2.000 50,80	13.000 330,20	LDSLV3	CR 84390	15.066 382,68	2.500 63,50	15.375 390,53	LDSLV4	CR 87569
	2.500 63,50	13.000 330,20	LDSLV4	CR 86722	15.188 385,77	0.750 19,05	15.438 392,13	LDSLV3	CR 84964
13.000 330,20	1.750 44,27	13.188 334,98	LDSLV4	CR 85535	15.250 387,35	0.906 23,01	15.750 400,05	LDSLV4	CR 85582
13.063 331,80	1.125 28,58	13.250 336,55	LDSLV4	CR 84963	15.560 395,22	2.500 63,50	16.000 406,40	LDSLV3	CR 87634
13.313 338,15	0.813 20,65	13.500 342,90	LDSLV4	CR 86688	15.812 401,63				
	1.500 38,10	13.500 342,90	LDSLV4	CR 87463					
	2.000 50,80	13.500 342,90	LDSLV3	CR 85852					

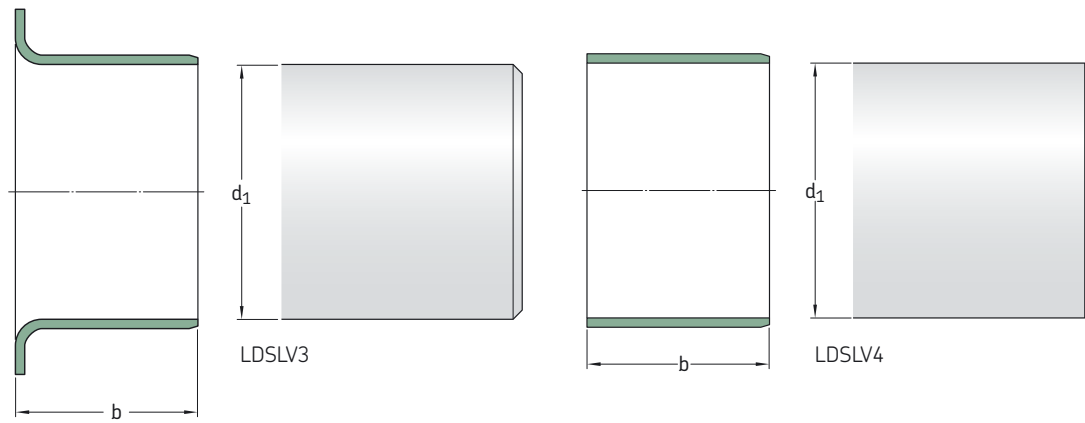

Shaft diameter	Sleeve width	For nominal seal inside diameter	Design	Designation	Shaft diameter	Sleeve width	For nominal seal inside diameter	Design	Designation
d_1	b				d_1	b			
in/mm		in/mm	-	-	in/mm		in/mm	-	-
15.813 401,65	2.000 50,80	16.000 406,40	LDSL4	CR 85181	17.543 445,59	2.362 60,00	17.731 450,37	LDSL4	CR 86799
	2.000 50,80	16.000 406,40	LDSL3	CR 87446	17.750 450,85	1.250 31,75	17.938 455,63	LDSL4	CR 90774
	2.500 63,50	16.000 406,40	LDSL4	CR 86407		2.500 63,50	17.938 455,63	LDSL3	CR 86631
15.998 406,35	2.250 57,15	16.188 411,18	LDSL3	CR 85908	17.812 452,42	2.125 53,98	18.000 457,20	LDSL4	CR 87271
16.000 406,40	2.000 50,80	16.188 411,18	LDSL3	CR 81354	17.813 452,45	2.500 63,50	18.000 457,20	LDSL3	CR 86405
16.063 408,00	0.500 12,70	16.250 412,75	LDSL4	CR 87613	18.163 461,34	2.000 50,80	18.350 466,09	LDSL4	CR 86343
	1.250 31,75	16.250 412,75	LDSL4	CR 86175	18.312 465,13	1.191 30,25	18.500 469,90	LDSL4	CR 90790
	1.300 33,02	16.250 412,75	LDSL4	CR 86426	18.813 477,82	1.750 44,45	19.000 482,60	LDSL4	CR 86563
	2.000 50,80	16.250 412,75	LDSL4	CR 86575		2.250 57,15	19.000 482,60	LDSL4	CR 87015
16.313 414,35	2.000 50,80	16.500 419,10	LDSL4	CR 84697		2.500 63,50	19.000 482,60	LDSL4	CR 86716
16.750 425,45	1.500 38,10	16.938 430,23	LDSL4	CR 87585	19.496 495,20	2.362 60,00	19.684 499,97	LDSL4	CR 87631
16.812 427,02	1.000 25,40	17.000 431,80	LDSL4	CR 86737	19.497 495,20	1.575 40,00	19.497 495,22	LDSL4	CR 87785
16.813 427,00	2.250 57,15	17.000 431,80	LDSL4	CR 84616	19.500 495,30	1.250 31,75	19.688 500,08	LDSL4	CR 90769
17.250 438,15	2.000 50,80	17.438 442,93	LDSL4	CR 84576	19.563 496,90	2.750 69,85	19.750 501,65	LDSL4	CR 85654
17.250 438,15	1.000 25,40	17.438 442,93	LDSL4	CR 90779	19.813 503,25	1.250 31,75	20.000 508,00	LDSL4	CR 84781
17.313 439,75	1.500 38,10	17.500 444,50	LDSL4	CR 86430	20.312 515,92	1.000 25,40	20.500 520,70	LDSL4	CR 86739
17.449 443,20	2.000 50,80	17.637 447,98	LDSL4	CR 85762	20.813 528,65	2.125 53,98	21.000 533,40	LDSL4	CR 85367
17.500 444,50	1.250 31,75	17.688 449,28	LDSL4	CR 90770		1.250 31,75	21.000 533,40	LDSL3	CR 85800
						2.500 63,50	21.000 533,40	LDSL4	CR 87298

Wear sleeves, series LDSLV – inch dimensions

d_1 20.865 – 42.500 in

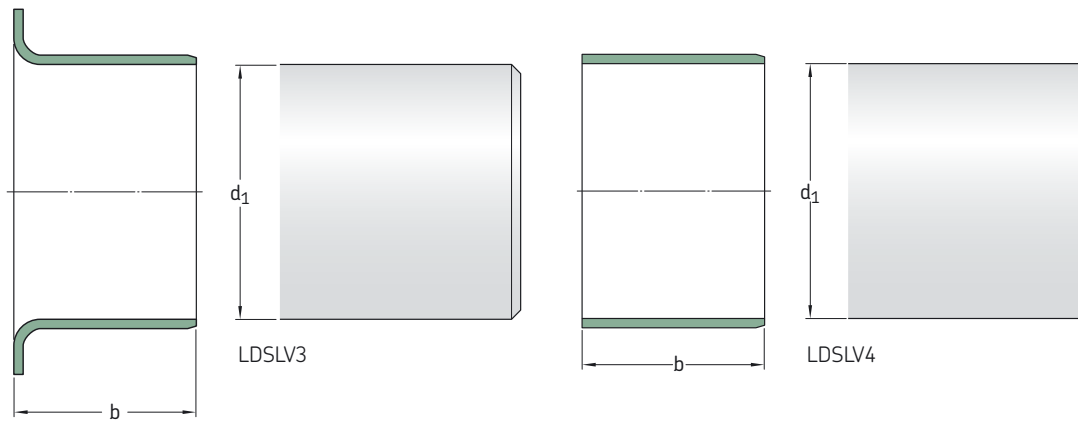

Shaft diameter	Sleeve width	For nominal seal inside diameter	Design	Designation	Shaft diameter	Sleeve width	For nominal seal inside diameter	Design	Designation
d_1	b				d_1	b			
in/mm		in/mm	–	–	in/mm		in/mm	–	–
20.865 529,97	2.250 57,15	21.053 534,75	LDSL4	CR 90805	26.000 660,40	2.250 63,50	26.188 665,18	LDSL3	CR 86640
20.990 533,15	2.250 57,15	21.178 537,92	LDSL3	CR 84579	26.312 668,33	1.375 34,93	26.500 673,10	LDSL4	CR 90809
21.000 533,40	2.250 57,15	21.188 538,18	LDSL4	CR 87090	26.813 681,05	1.250 31,75	27.000 685,80	LDSL4	CR 85384
21.803 553,80	2.362 60,00	21.991 558,57	LDSL4	CR 87069		2.250 57,15	27.000 685,80	LDSL4	CR 85531
21.813 554,04	2.250 57,15	22.000 558,80	LDSL4	CR 84590	27.000 685,80	2.000 50,80	27.188 690,58	LDSL4	CR 86841
22.250 565,15	1.000 25,40	22.438 569,93	LDSL3	CR 85691	27.063 687,40	2.250 57,15	27.250 692,15	LDSL4	CR 84764
22.303 566,50	2.362 60,00	22.491 571,27	LDSL4	CR 87070	27.313 693,75	2.250 57,15	27.500 698,50	LDSL4	CR 85011
22.313 566,75	1.250 31,75	22.500 571,50	LDSL4	CR 85907	27.500 695,50	2.250 57,15	27.688 703,28	LDSL4	CR 84711
22.812 579,43	2.000 50,80	23.000 584,20	LDSL4	CR 90163	27.812 706,43	2.500 63,50	28.000 711,20	LDSL4	CR 87421
23.000 584,20	2.000 50,80	23.188 588,98	LDSL4	CR 90146	28.312 719,13	2.313 58,75	28.500 723,90	LDSL3	CR 87623
23.434 595,22	0.984 25,00	23.434 595,22	LDSL4	CR 87777	28.813 731,84	2.250 57,15	29.000 736,60	LDSL4	CR 84641
23.687 601,65	1.950 49,53	23.875 606,43	LDSL4	CR 87907	29.813 757,24	2.250 57,15	30.000 762,00	LDSL4	CR 84642
23.812 604,83	0.750 19,05	24.000 609,60	LDSL4	CR 87922	30.000 762,00	2.500 63,50	30.188 766,78	LDSL3	CR 86641
	2.500 63,50	24.000 609,60	LDSL4	CR 87960	30.309 769,85	1.375 34,93	30.497 774,62	LDSL4	CR 87530
25.000 635,00	2.500 63,50	25.188 639,78	LDSL4	CR 86567	30.312 769,93	2.500 63,50	30.500 774,70	LDSL3	CR 87842
25.312 642,93	2.500 63,50	25.500 647,70	LDSL4	CR 87802	30.813 782,65	2.000 50,80	31.000 787,40	LDSL4	CR 85039
25.313 642,95	2.000 50,80	25.500 647,70	LDSL4	CR 86091	31.812 808,03	2.500 63,50	32.000 812,80	LDSL4	CR 90810

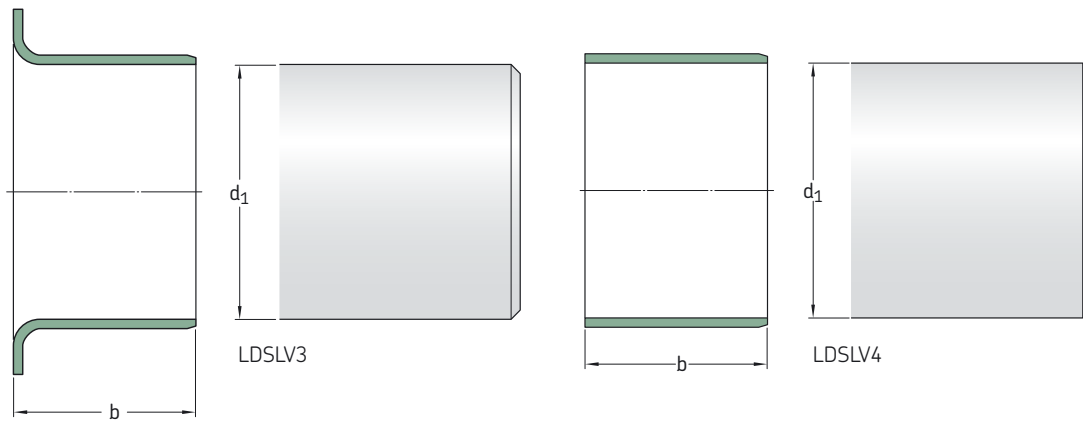

Shaft diameter	Sleeve width	For nominal seal inside diameter	Design	Designation	Shaft diameter	Sleeve width	For nominal seal inside diameter	Design	Designation
d_1	b				d_1	b			
<i>in/mm</i>		<i>in/mm</i>	-	-	<i>in/mm</i>		<i>in/mm</i>	-	-
32.313 820,75	2.000 50,80	32.500 825,50	LDSLV4	CR 86090	42.312 1 074,72	1.250 31,75	42.500 1 079,50	LDSLV4	CR 87379
32.812 833,43	2.220 56,39	33.000 838,20	LDSLV4	CR 87850	42.500 1 079,50	1.250 31,75	42.688 1 084,28	LDSLV4	CR 87392
33.313 846,15	2.625 66,68	33.500 850,90	LDSLV4	CR 84730					
34.312 871,58	1.750 44,45	34.500 876,30	LDSLV4	CR 87529					
35.313 896,95	2.500 63,50	35.500 901,70	LDSLV4	CR 85814					
35.812 909,63	1.500 38,10	36.000 914,40	LDSLV4	CR 90332					
36.375 923,93	2.500 63,50	36.555 928,50	LDSLV4	CR 86111					
36.813 935,05	2.500 63,50	37.000 939,80	LDSLV4	CR 86458					
37.813 960,45	1.500 38,10	38.000 965,20	LDSLV4	CR 86973					
38.000 965,20	1.500 38,10	38.188 969,98	LDSLV4	CR 86840					
38.500 977,90	1.500 38,10	38.688 982,68	LDSLV4	CR 81753					
38.813 985,85	2.125 53,98	39.000 990,60	LDSLV4	CR 85123					
39.813 1 011,24	2.125 54,00	40.000 1 016,00	LDSLV4	CR 81826					
41.312 1 049,33	1.968 49,99	41.500 1 054,10	LDSLV4	CR 89948					
42.063 1 068,40	2.125 53,98	42.250 1 073,15	LDSLV4	CR 85038					
42.125 1 070,00	2.125 53,98	42.313 1 074,75	LDSLV4	CR 87054					

SKF – the knowledge engineering company

From the company that invented the self-aligning ball bearing more than 100 years ago, SKF has evolved into a knowledge engineering company that is able to draw on five technology platforms to create unique solutions for its customers. These platforms include bearings, bearing units and seals, of course, but extend to other areas including: lubricants and lubrication systems, critical for long bearing life in many applications; mechatronics that combine mechanical and electronics knowledge into systems for more effective linear motion and sensorized solutions; and a full range of services, from design and logistics support to conditioning monitoring and reliability systems.

Though the scope has broadened, SKF continues to maintain the world's leadership in the design, manufacture and marketing of rolling bearings, as well as complementary products such as radial seals. SKF also holds an increasingly important position in the market for linear motion products, high-precision aerospace bearings, machine tool spindles and plant maintenance services.

The SKF Group is globally certified to ISO 14001, the international standard for environmental management, as well as OHSAS 18001, the health and safety management standard. Individual divisions have been approved for quality certification in accordance with either ISO 9000 or QS 9000.

With some 100 manufacturing sites worldwide and sales companies in 70 countries, SKF is a truly international corporation. In addition, our distributors and dealers in some 15 000 locations around the world, an e-business marketplace and a global distribution system put SKF close to customers for the supply of both products and services. In essence, SKF solutions are available wherever and whenever customers need them. Overall, the SKF brand and the corporation are stronger than ever. As the knowledge engineering company, we stand ready to serve you with world-class product competencies, intellectual resources, and the vision to help you succeed.



© Airbus – photo: e'm company, H. Goussé

Evolving by-wire technology

SKF has a unique expertise in fast-growing by-wire technology, from fly-by-wire, to drive-by-wire, to work-by-wire. SKF pioneered practical fly-by-wire technology and is a close working partner with all aerospace industry leaders. As an example, virtually all aircraft of the Airbus design use SKF by-wire systems for cockpit flight control.

SKF is also a leader in automotive by-wire technology, and has partnered with automotive engineers to develop two concept cars, which employ SKF mechatronics for steering and braking. Further by-wire development has led SKF to produce an all-electric forklift truck, which uses mechatronics rather than hydraulics for all controls.

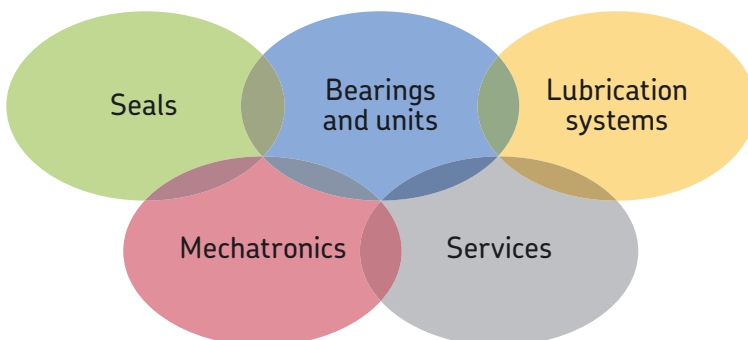



Harnessing wind power

The growing industry of wind-generated electric power provides a source of clean, green electricity. SKF is working closely with global industry leaders to develop efficient and trouble-free turbines, providing a wide range of large, highly specialized bearings and condition monitoring systems to extend equipment life of wind farms located in even the most remote and inhospitable environments.



Working in extreme environments

In frigid winters, especially in northern countries, extreme sub-zero temperatures can cause bearings in railway axleboxes to seize due to lubrication starvation. SKF created a new family of synthetic lubricants formulated to retain their lubrication viscosity even at these extreme temperatures. SKF knowledge enables manufacturers and end user customers to overcome the performance issues resulting from extreme temperatures, whether hot or cold. For example, SKF products are at work in diverse environments such as baking ovens and instant freezing in food processing plants.



Developing a cleaner cleaner

The electric motor and its bearings are the heart of many household appliances. SKF works closely with appliance manufacturers to improve their products' performance, cut costs, reduce weight, and reduce energy consumption. A recent example of this cooperation is a new generation of vacuum cleaners with substantially more suction. SKF knowledge in the area of small bearing technology is also applied to manufacturers of power tools and office equipment.



Maintaining a 350 km/h R&D lab

In addition to SKF's renowned research and development facilities in Europe and the United States, Formula One car racing provides a unique environment for SKF to push the limits of bearing technology. For over 50 years, SKF products, engineering and knowledge have helped make Scuderia Ferrari a formidable force in F1 racing. (The average racing Ferrari utilizes more than 150 SKF components.) Lessons learned here are applied to the products we provide to auto-makers and the aftermarket worldwide.



Delivering Asset Efficiency Optimization

Through SKF Reliability Systems, SKF provides a comprehensive range of asset efficiency products and services, from condition monitoring hardware and software to maintenance strategies, engineering assistance and machine reliability programmes. To optimize efficiency and boost productivity, some industrial facilities opt for an Integrated Maintenance Solution, in which SKF delivers all services under one fixed-fee, performance-based contract.



Planning for sustainable growth

By their very nature, bearings make a positive contribution to the natural environment, enabling machinery to operate more efficiently, consume less power, and require less lubrication. By raising the performance bar for our own products, SKF is enabling a new generation of high-efficiency products and equipment. With an eye to the future and the world we will leave to our children, the SKF Group policy on environment, health and safety, as well as the manufacturing techniques, are planned and implemented to help protect and preserve the earth's limited natural resources. We remain committed to sustainable, environmentally responsible growth.



© SKF and SPEEDI-SLEEVE are registered trademarks of the SKF Group.

© SKF Group 2008

The contents of this publication are the copyright of the publisher and may not be reproduced (even extracts) unless permission is granted. Every care has been taken to ensure the accuracy of the information contained in this publication but no liability can be accepted for any loss or damage whether direct, indirect or consequential arising out of the use of the information contained herein.

The data in this publication may differ from that shown in earlier publications because of redesign, technological developments or revised methods of calculation. SKF reserves the right to make continuing improvements to SKF products without prior notice with respect to materials, design and manufacturing methods, as well as changes necessitated by technological developments.

Publication **6403/I EN** · March 2008

This publication supersedes publications 5149 E and 457027.

Printed in Sweden on environmentally friendly paper.

skf.com