

# SE design bearing housings

A new generation of SKF housings designed for maximum reliability and minimal maintenance



Since their introduction several decades ago, SKF housings have set the standard for split plummer (pillow) block housings. Now SKF engineers have improved on the SNL design, creating a new generation of bearing housings manufactured with even better quality materials, higher machining accuracy, and a number of new features that improve the serviceability of these robust units. In addition to extending the service life of bearings, particularly in applications where a locating/non-locating bearing arrangement is used, SE design housings deliver significant environmental advantages over the housings they replace.

## Benefits

- Longer bearing service life
- Higher corrosion resistance
- Reduced grease usage
- Easier servicing
- Reduced environmental impact

## Typical industries, examples

- Mining, mineral processing and cement
- Material handling
- Metals
- Fluid machinery
- Marine



# Reduce total cost of ownership and environmental impact



SE design housings from SKF offer improvements over SNL housings in three important areas: quality, serviceability and environmental impact. These symbols, included with product features on the following pages, indicate the areas in which SE design housings are superior to other bearing housings on the market today.



## Environmental Product Declaration; EPD

In SKF's continuing efforts to reduce environmental impact, a declaration of the environmental performance of SE housings is described in an EPD according to ISO 14025. The scope of the EPD is from 'cradle to cradle' and the content is:

- Description of the SE housing
- Description of its material
- Description of its production
- Description of its area of use in the final product
- Description of end of life

## Highlights

- **Upgraded materials and new design** – provides a stiffer, more robust housing that minimizes distortion of the base and bearing seat during installation
- **Improved machining accuracy** – results in a more accurate bearing seat in the housing, which reduces vibration and the resulting heat to extend bearing and grease service life
- **Improved heat dissipation** – lowers operating temperatures to help extend grease and bearing service life
- **Improved corrosion protection** – provides C3 class protection according to ISO 12944
- **Improved lubrication distribution** – less grease usage, better bearing lubrication as a result of a more efficient grease guiding system
- **Improved serviceability** – simplified mounting and alignment, condition monitoring locations clearly identified

## Design and manufacturing improvements

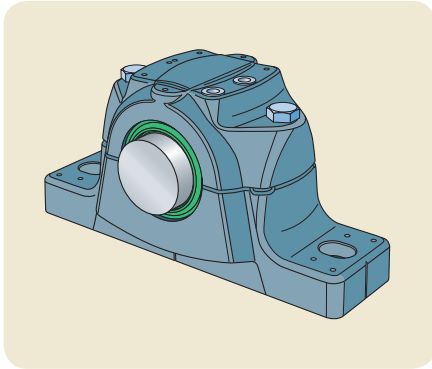

### A modular design concept for a wide range of options

Like SNL housings, SE plummer block housings are split housings consisting of a cap and base. They have two holes as standard cast into the base for attachment bolts. The housings are based on a modular design concept to enable a wider choice of bearings and seals as well as a variety of bearing-shaft combinations and lubrication methods.

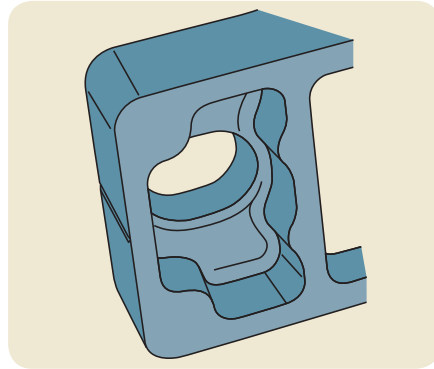

### Stiffer, more robust housing

The new, optimized design of SE plummer block housings, together with their improved material grade, make them more robust compared to SNL housings; and the breaking loads are higher in some directions. With larger ribs in the base and additional material around the holes for attachment bolts, SE housings are stiffer than their predecessors.

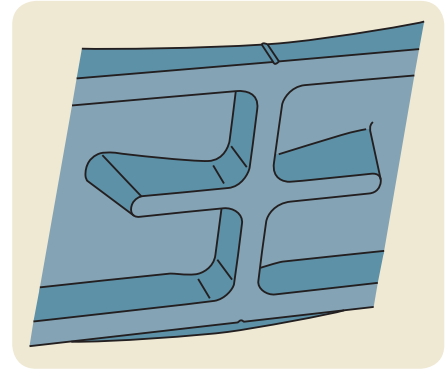

### Better heat dissipation

The ribs around the perimeter and in the centre of the base are larger, to increase the contact area between the base and support surface. This reduces operating temperatures and increases the service life of the bearings, seals and lubricant.

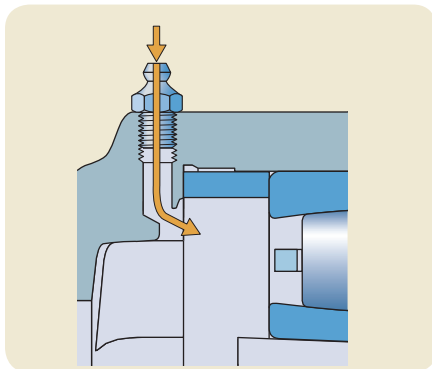

### Efficient grease guiding system

For more efficient lubrication from the side, SE housings from size 511-609 onwards have an integrated flange that guides grease from the grease fitting directly to the bearing. This can reduce grease consumption, meaning less grease for disposal. Also, to prevent over-filling the housing, markings inside the housing base, at each corner, indicate the proper grease level for an initial 20 or 40% fill.

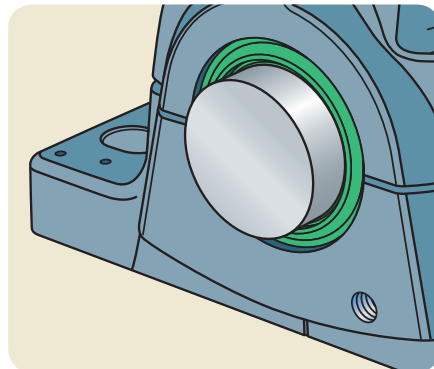

### Repositioned grease escape hole for easier access

The position of the grease escape hole has been optimized for easier access, compared to SNL housings.

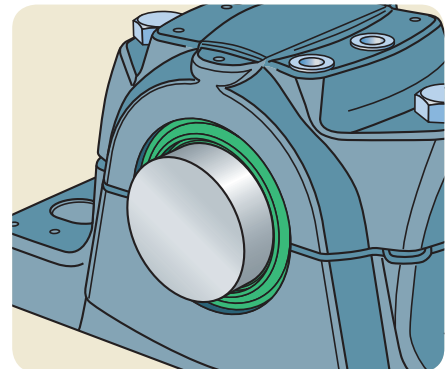

### Better corrosion protection

SE housings are well protected from corrosion. The corrosivity category of the paint is higher than for SNL housings. SE plummer block housings are painted graphite grey using a water based alkyd/acryl paint. The paint protects the housing in accordance with ISO 12944-2:1998, corrosivity category C3. Unpainted surfaces are protected by a solventless rust inhibitor.

## Improvements for more accurate and efficient servicing

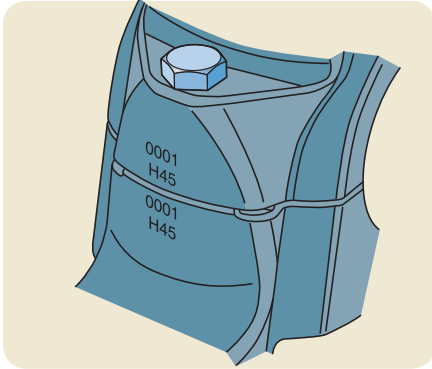

### Improved markings on the housing

The housing cap and base are matched during manufacture and are not interchangeable with the caps and bases of other housings. The serial number on both housing parts is more readable to help avoid any mismatches. The designation on the housing cap has also been enhanced for readability and now contains the complete housing designation for better traceability.

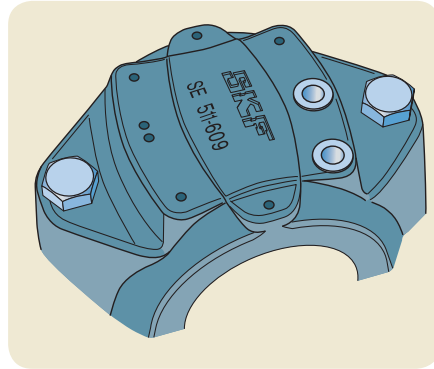

### Dimples to locate accessories and improved lubrication facilities

Dimples cast into the housing cap indicate where grease fittings and condition monitoring sensors can be mounted for maximum effectiveness.

In addition, the hole in the housing cap for relubrication through the centre of the bearing is positioned off-centre to the shaft axis.

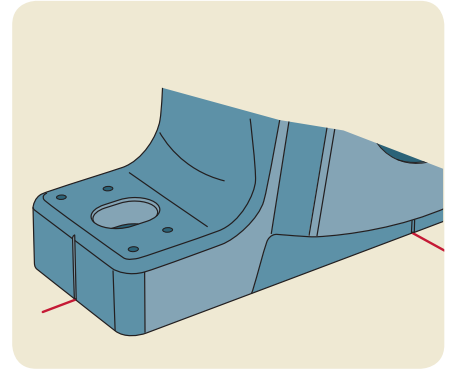

### Simple mounting and dismounting

To simplify mounting and make alignment more accurate, lines indicating the centre of the bearing seat and housing bore axis are cast into the housing base. Dimples indicate the position for dowel pins.

Mounting instructions are supplied with each seal pack. Housings from size 519-616 and above have an eyebolt on the cap for safe, easy handling.

Additionally, the grease fitting kit contains tightening torque values for the cap bolts and values for initial grease fills. The new housings have a slot between the cap and base, making it easier to remove the cap for maintenance.

## Product data

SE design housings will supersede SNL plummer (pillow) block housings. In general, information for SE housings with regards to housing variants, sealing solutions, system design, lubrication, mounting, condition monitoring and accessories is the same as for SNL housings. There are, however, two exceptions that should be taken into consideration.

### Initial grease fill

The initial grease fill for an SE housing is different to an SNL housing. Values for 20 and 40% grease fills for SE housings are supplied with the grease fitting kit.

### Torque values for cap bolts

The torque specification for two sizes of SE housings cap bolts are different than those for SNL housings.

The new torque values for SE 516-613 and SE 517 are supplied with the grease fitting kit.



# Even longer bearing service life with the SKF self-aligning bearing system

## The problem

The typical locating/non-locating bearing arrangement in an industrial application has to accommodate misalignment, shaft deflections and thermal elongation of the shaft. In the typical arrangement, shaft elongation requires the non-locating bearing to move on its seat in the housing. This induces axial loads, vibration and heat, which ultimately shorten the service life of the bearings and lubricant.

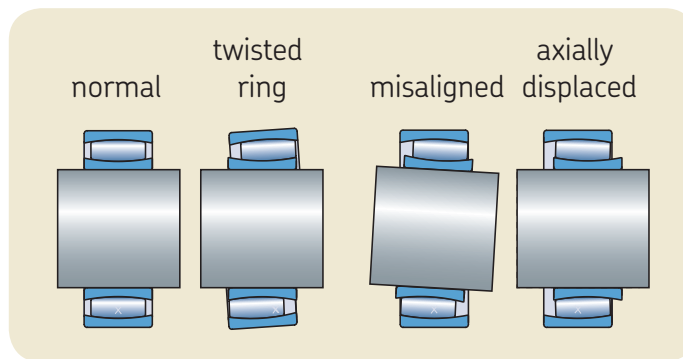

*The rollers of CARB bearings always adopt the position where the load is favorably distributed over its entire length.*

## The solution

The SKF self-aligning bearing system accommodates misalignment and shaft deflections, but also accommodates thermal elongation of the shaft. To do this, the SKF system replaces the spherical roller or self-aligning ball bearing in the non-locating position, with a CARB toroidal roller bearing. The CARB bearing accommodates axial displacement like a cylindrical roller bearing, with virtually no friction. This avoids the problem of induced axial loads, vibration and heat, to extend bearing and lubricant service life and potentially enable bearings and housings to be downsized for cost and weight savings.

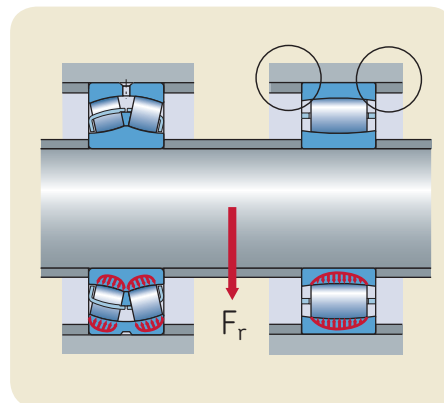

*By avoiding induced axial loads, both bearings share the radial load evenly.*

*Please note that when using a CARB bearing, both the inner and outer rings must be located axially.*

## Longer service life

SE design bearing housings from SKF can further extend the service life of an SKF self-aligning bearing system. This is the result of a number of upgrades to SNL housings, from more robust material, new design and more precise machining, to improved heat dissipation and lubrication.

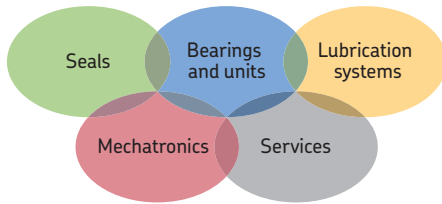

### The Power of Knowledge Engineering

Drawing on five areas of competence and application-specific expertise amassed over more than 100 years, SKF brings innovative solutions to OEMs and production facilities in every major industry worldwide. These five competence areas include bearings and units, seals, lubrication systems, mechatronics (combining mechanics and electronics into intelligent systems), and a wide range of services, from 3-D computer modelling to advanced condition monitoring and reliability and asset management systems. A global presence provides SKF customers uniform quality standards and worldwide product availability.

© SKF and CARB are registered trademarks of the SKF Group.

© SKF Group 2012

The contents of this publication are the copyright of the publisher and may not be reproduced (even extracts) unless prior written permission is granted. Every care has been taken to ensure the accuracy of the information contained in this publication but no liability can be accepted for any loss or damage whether direct, indirect or consequential arising out of the use of the information contained herein.

PUB BU/S9 12521 EN · February 2012

Certain image(s) used under license from Shutterstock.com

